

Specifications:
 规格:
 Voltage rating: 250V AC/DC
 额定电压: 250V AC/DC
 Current rating: 1A AC/DC
 额定电流: 1A AC/DC
 Withstanding voltage: 800V AC/minute
 耐受电压: 800V AC/分钟
 Temperature range: -25°C +85°C
 温度范围: -25°C +85°C
 Insulation resistance: ≥1000MΩ
 绝缘电阻: ≥1000MΩ
 Contact resistance: ≤10mΩ
 接触电阻: ≤10mΩ

X2081 W V - 2xXX - N0 SN
 ① ② ③ ④ ⑤ ⑥

1. Series No
2. Category: W-Wafer
3. Welding Board Angle: V-Stright 180°
4. Row No. Pin No: 2xXX-2X05~2x20P
5. Material: N0-PA66 UL94V-0
6. Plating: SN-Bright Tin Plated

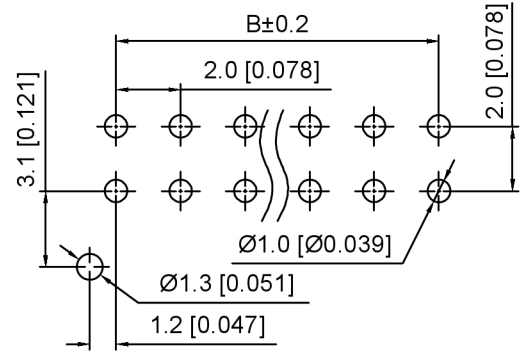
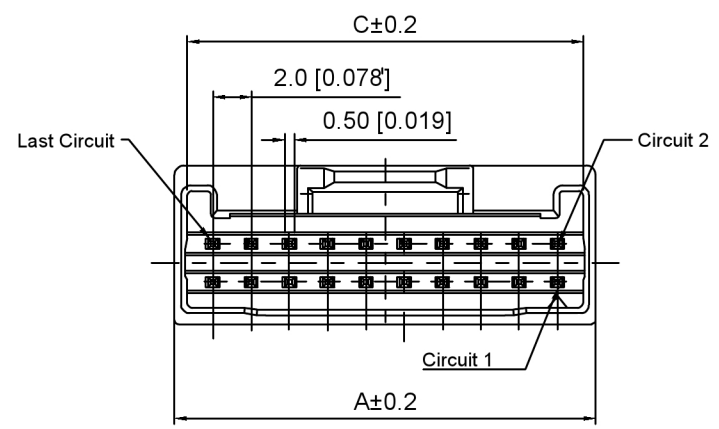

PCB LAYOUT

Poles	Dimensions(mm)				Poles	Dimensions(mm)			
	A	B	C	D		A	B	C	D
2x05	12.00	8.00	10.70	7.30	2x13	28.00	24.00	26.70	7.30
2x06	14.00	10.00	12.70	9.20	2x14	30.00	26.00	28.70	9.20
2x07	16.00	12.00	14.70		2x15	32.00	28.00	30.70	
2x08	18.00	14.00	16.70		2x16	34.00	30.00	32.70	
2x09	20.00	16.00	18.70		2x17	36.00	32.00	34.70	
2x10	22.00	18.00	20.70		2x18	38.00	34.00	36.70	
2x11	24.00	20.00	22.70		2x19	40.00	36.00	38.70	
2x12	26.00	22.00	24.70		2x20	42.00	38.00	40.70	

X2081WV-2xXX-N0SN	PA66	Brass	X2081H
PART NO	Material	Material(Pin)	Suitable XKB Housing

广东星坤科技股份有限公司

4x	日期
4x	日期
4x	日期

文件工程草

MARK	DESCRIPTION	DATE	REVISED	APPROVED	UNSPECIFIED TOLERANCES
					ANGULAR ±5°
					L ≤ 4 ±0.2
					4 < L ≤ 16 ±0.3
					16 < L ≤ 63 ±0.4
					L > 63 ±0.5



DSND	SCALE: N/A	MODEL TYPE: 2.0mm Crimp Style Connector
DWN	VIEW:	PART NO.: X2081WV-2xXX-N0SN
CHKD	UNIT: mm/in	DWG NO.: X-X2081WV-2xXX-N0SN
APPD	SIZE: A4	WEIGHT SHEET REVISION
XKB INDUSTRIAL PRECISION CO., LIMITED		1/1 A0

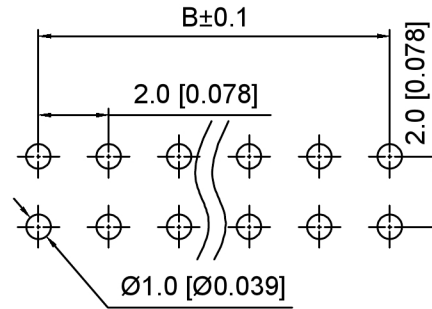
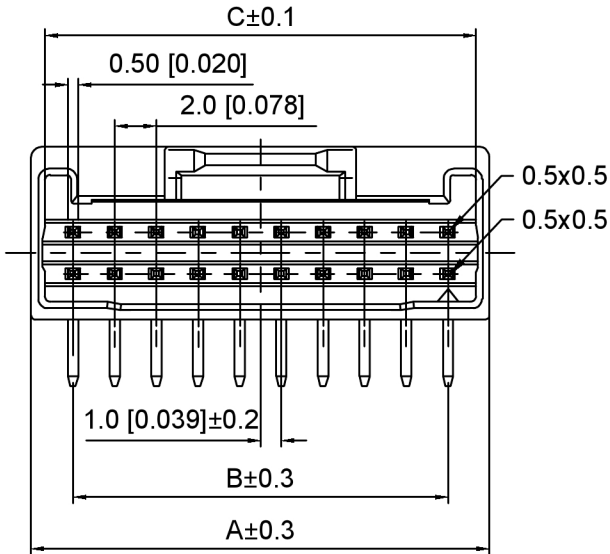
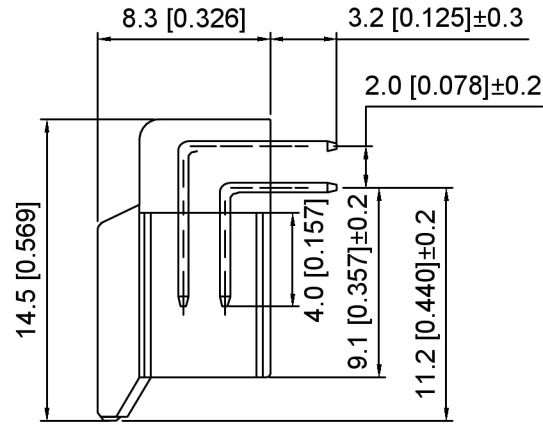
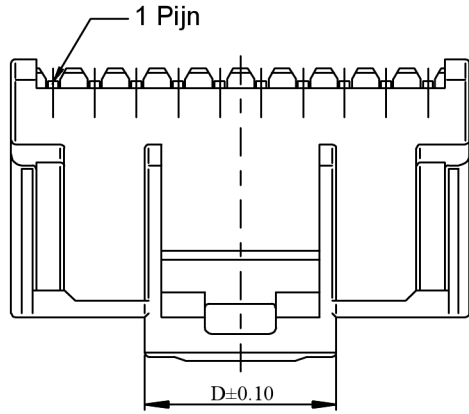

PCB LAYOUT

Specifications:

规格:

Voltage rating:250V AC/DC

额定电压: 250V AC/DC

Current rating:1A AC/DC

额定电流: 1A AC/DC

Withstanding voltage:800V AC/minute

耐受电压: 800V AC/分钟

Temperature range:-25℃-+105℃

温度范围: -25℃-+105℃

Insulation resistance:≥1000MΩ

绝缘电阻: ≥1000MΩ

Contact resistance:≤10mΩ

接触电阻: ≤10mΩ

X2081 W R - 2xXX - N0 SN
 ① ② ③ ④ ⑤ ⑥

1.Series No

2.Category:W-Wafer

3.Welding Board Angle:R-Stright 90°

4.Row No.Pin No:2xXX-2X05~2x20P

5.Material:N0-PA66 UL94V-0

6.Plating:SN-Bright Tin Plated

Poles	Dimensions(mm)				Poles	Dimensions(mm)			
	A	B	C	D		A	B	C	D
2x05	12.00	8.00	10.70	7.30	2x13	28.00	24.00	26.70	7.30
2x06	14.00	10.00	12.70	9.20	2x14	30.00	26.00	28.70	9.20
2x07	16.00	12.00	14.70		2x15	32.00	28.00	30.70	
2x08	18.00	14.00	16.70		2x16	34.00	30.00	32.70	
2x09	20.00	16.00	18.70		2x17	36.00	32.00	34.70	
2x10	22.00	18.00	20.70		2x18	38.00	34.00	36.70	
2x11	24.00	20.00	22.70		2x19	40.00	36.00	38.70	
2x12	26.00	22.00	24.70		2x20	42.00	38.00	40.70	

X2081WR-2xXX-N0SN	PA66	Brass	X2081H
PART NO	Material	Material(Pin)	Suitable XKB Housing

DSND	SCALE: N/A	MODEL TYPE: 2.0mm Crimp Style Connector
DWN	VIEW:	PART NO.: X2081WR-2xXX-N0SN
CHKD	UNIT: mm/in	DWG NO.:
APPD	SIZE: A4	X-X2081WR-2xXX-N0SN



XKB INDUSTRIAL PRECISION CO.,LIMITED

WEIGHT	SHEET	REVISION
	1/1	A0

广东星坤科技股份有限公司

Δx	日期
Δx	日期
Δx	日期
MARK	DESCRIPTION

文件工程章

ANGLAR	±5°
L≤ 4	±0.2
4<L≤ 16	±0.3
16<L≤ 63	±0.4
L> 63	±0.5
UNSPECIFIED TOLERANCES	

REVISIONS	DATE	REVISED	APPROVED	UNSPECIFIED TOLERANCES
www.helloxkb.com www.helloxkb.cn www.xk-dg.cn				

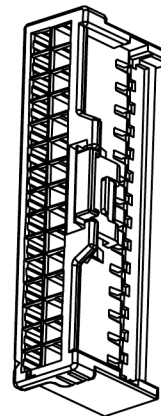
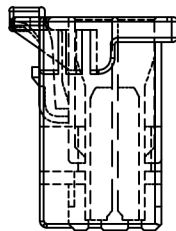
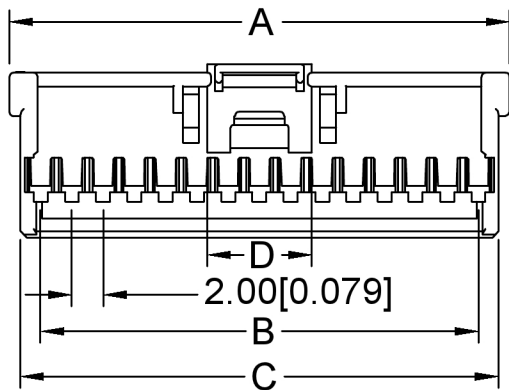

Specifications:
 规格:
 Voltage rating: 250V AC/DC
 额定电压: 250V AC/DC
 Current rating: 3A AC/DC
 额定电流: 3A AC/DC
 Withstanding voltage: 1000V AC/minute
 耐受电压: 1000V AC/分钟
 Temperature range: -25°C~+85°C
 温度范围: -25°C~+85°C
 Insulation resistance: ≥1000MΩ
 绝缘电阻: ≥1000MΩ
 Contact resistance: ≤10mΩ
 接触电阻: ≤10mΩ
 After environmental testing: ≤20mΩ
 环境测试后: ≤20兆欧

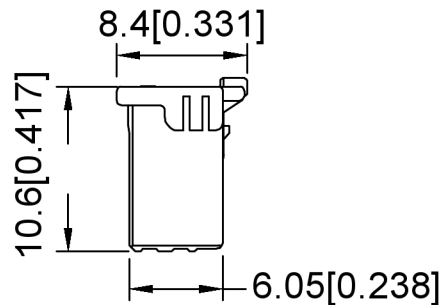
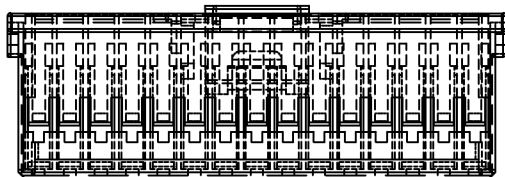

X2081 H-2xXX-N0

① ② ③ ④

1. Series No
2. Category: H-HSG
3. Row No-Pin No: 2xXX-2x05P~2x20P
5. Material: N0-PA66 94V-0

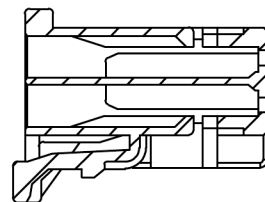
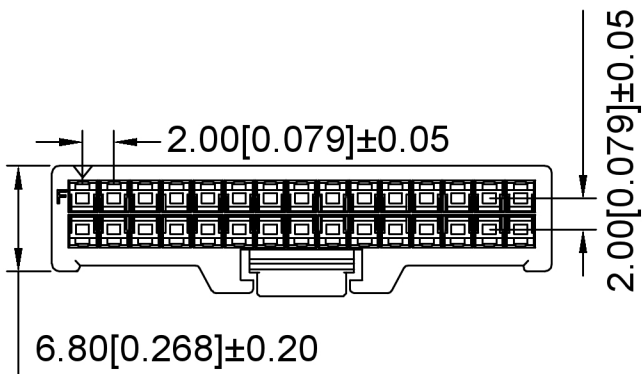

截面 B-B

Poles	Dimension(mm)				Poles	Dimension(mm)			
	A	B	C	D		A	B	C	D
10	12.00	8.00	10.60	5.10	26	28.00	24.00	26.60	6.80
12	14.00	10.00	12.60	6.80	28	30.00	26.00	28.60	6.80
14	16.00	12.00	14.60	6.80	30	32.00	28.00	30.60	6.80
16	18.00	14.00	16.60	6.80	32	34.00	30.00	32.60	6.80
18	20.00	16.00	18.60	6.80	34	36.00	32.00	34.60	6.80
20	22.00	18.00	20.60	6.80	36	38.00	34.00	36.60	6.80
22	24.00	20.00	22.60	6.80	38	40.00	36.00	38.60	6.80
24	26.00	22.00	24.60	6.80	40	42.00	38.00	40.60	6.80

X2081H-2xXX-N0	PA66 UL 94V-0	X2081W	X2081T
PART NO	Material	Suitable XKB Wafer	Suitable XKB Terminal

广东星坤科技股份有限公司

Δx	日期
Δx	日期
Δx	日期

文件工程章

MARK	DESCRIPTION	DATE	REVISED	APPROVED	ANGLAR	±5°
					L ≤ 4	±0.2
					4 < L ≤ 16	±0.3
					16 < L ≤ 63	±0.4
					L > 63	±0.5
					UNSPECIFIED TOLERANCES	



DSND	SCALE: N/A	MODEL TYPE: 2.0mm Crimp Style Connector
DWN	VIEW:	PART NO.: X2081H-2xXX-N0
CHKD	UNIT: mm/in	DWG NO.: X-X2081H-2xXX-N0
APPD	SIZE: A4	WEIGHT
XKB INDUSTRIAL PRECISION CO., LIMITED		SHEET
		REVISION
		1/1
		A0

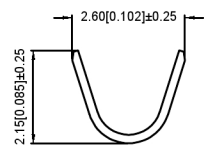
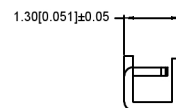
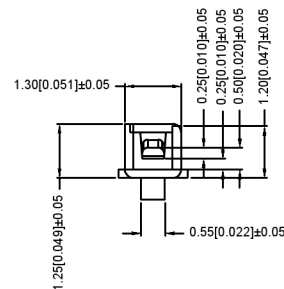
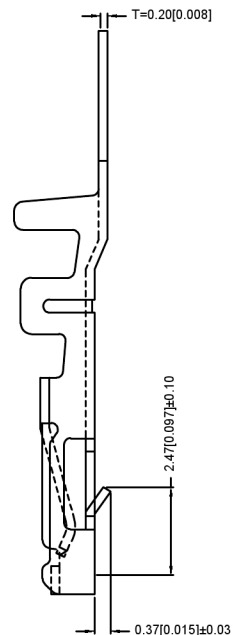
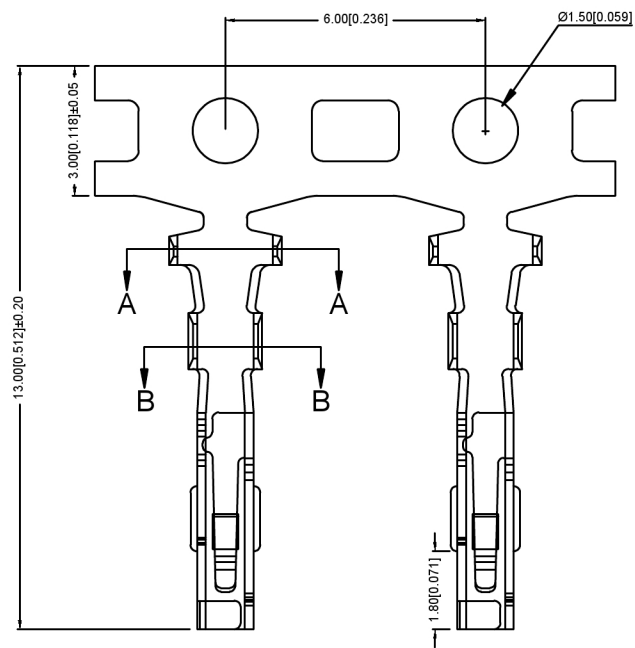

Section: A-A

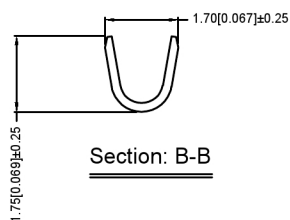

Section: B-B

Specifications:

规格:

Voltage rating:125V AC/DC

额定电压: 125V AC/DC

Current rating:2A AC/DC

额定电流: 2A AC/DC

Withstanding voltage:500V AC/minute

耐受电压: 500V AC/分钟

Temperature range:-40°C-+105°C

温度范围: -40°C-+105°C

Insulation resistance:≥1000MΩ

绝缘电阻: ≥1000MΩ

Contact resistance:≤20mΩ

接触电阻: ≤20mΩ

After environmental testing:≤30mΩ

环境测试后: ≤30兆欧

X2081 T - P XX

① ② ③ ④

1. Series Number

2. Category:T-terminal

3. Material:P-Phosphor bronze

4. Plating style:SN-Bright tin plating;V01-Gold Flash

X2081T-PSN	phosphor Bronze	AWG#22-28	1.4mm(Max)	15u"Ni;70u" Sn	X2081H
PART NO	Material	Wire Range	Insulation OD	Finish	Suitable XKB Terminal

广东星坤科技股份有限公司

DATE	日期
DESCRIPTION	文件工程章

ANGLAR	±5°
L ≤ 4	±0.2
4 < L ≤ 16	±0.3
16 < L ≤ 63	±0.4
L > 63	±0.5
UNSPECIFIED TOLERANCES	



DSND	SCALE: N/A	MODEL TYPE: 2.0mm Crimp Style Connector		
DWN	VIEW:	PART NO.: X2081T-PSN		
CHKD	UNIT: mm/in	DWG NO.: X-X2081T-PSN		
APPD	SIZE: A4	WEIGHT	SHEET	REVISION
XKB INDUSTRIAL PRECISION CO., LIMITED			1/1	A0