

# IP65

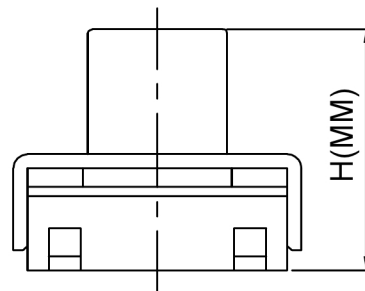

PCB Mounting  
pattern Dimension

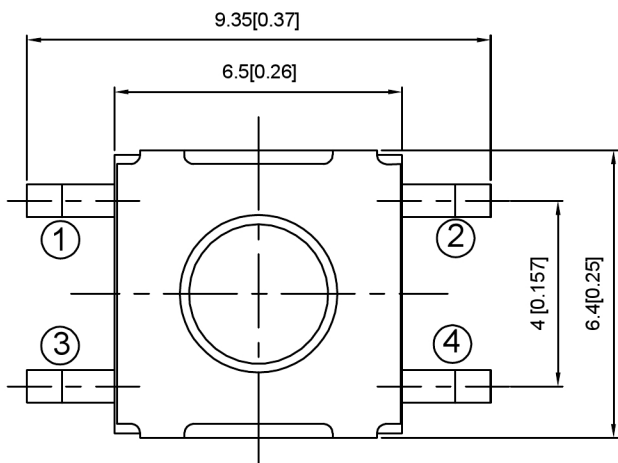
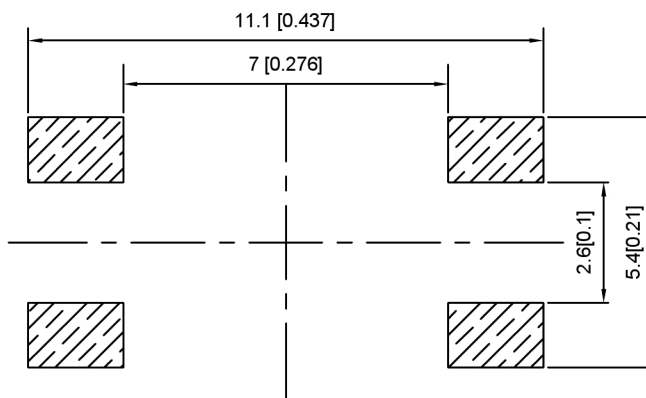

## SPECIFICATION

Contact Rating: 50mA, 12V DC  
 Contact Resistance: 100mΩ max  
 Insulation Resistance: 100mΩ min. 500V DC  
 Dielectric Strength: 250V AC/1minute  
 Travel: 0.25mm  
 Operating Temp: -30°C ~ +85°C  
 Storage Temp: -30°C ~ +80°C

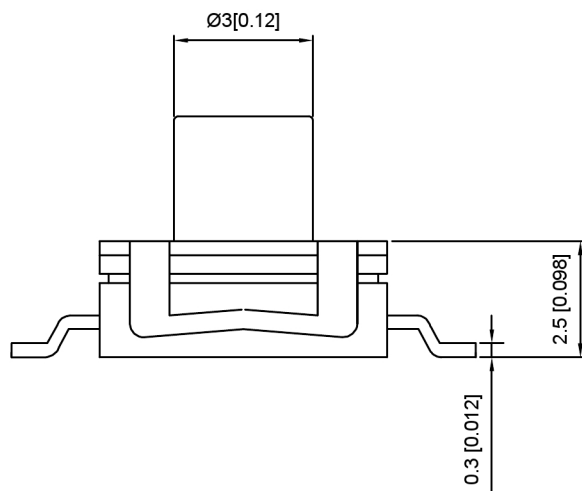

PAPT NO	TS-1158B-X-X-X
Operating Force	B:160gf C:260gf E:400gf
Height	H: A:3.1 B:3.5 C:4.3 D:5.0
Color	BL:blue W:white

Circuit Diagram

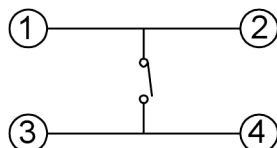

⑤	Terminal	—	4	Brass (0.30t)	Plating silvering	—
④	Contact	—	1	F. ag/Sus	Natural	—
③	Base	—	1	PA46		—
②	Cover	—	1	SPSS	Plating Nickel	—
①	Keystake	—	1	Silica gel		—
ITEM	PAPT NAMF	TER,NO	QTY	MATERIAL	FINISHING	REMARK

广东星坤科技股份有限公司

Δx	日期
Δx	日期
Δx	日期
MARK	DESCRIPTION

文件工程章

REVISIONS	DATE	REVISED	APPROVED	UNSPECIFIED TOLERANCES

ANGLAR ±5°  
 L ≤ 4 ±0.2  
 4 < L ≤ 16 ±0.3  
 16 < L ≤ 63 ±0.4  
 L > 63 ±0.5

**XKIB**

XKB INDUSTRIAL PRECISION CO., LIMITED

DSND	SCALE: N/A	MODEL TYPE: TACT SWITCH
DWN	VIEW:	PART NO.: TS-1158B-X-X-X
CHKD	UNIT: mm/in	DWG NO.:
APPD	SIZE: A4	
	WEIGHT	SHEET 1/1
		REVISIC A0