



MOV Varistors

2008



WALSIN[®] 華新科技
Walsin Technology Corporation

Yang-Mei

Walsin Technology Corporation
566-1, Kao-Shi Road, Yang-Mei,
Tao-Yuan, Taiwan
Tel: 886-3-475-8711
Fax: 886-3-475-7129 475-7130
E-mail: info@passivecomponent.com

Kaohsiung

Walsin Technology Corporation
1st, West 13 Street, K.E.P.Z.
Kaohsiung, Taiwan
Tel: 886-7-821-8171
Fax: 886-7-813-1661
E-mail: info@passivecomponent.com

Feb. 2008

Subject	Page
Metal Oxide Varistor (MOV)	1
Varistors-5D Series	3
Varistors-7D Series	4
Varistors-10D Series	5
Varistors-14D Series	6
Varistors-20D Series	7
Varistors-25D Series	8
Varistors-5E \ 7E Series.....	9
Varistors-10E \ 14E Series.....	10
Varistors-18E \ 20E Series.....	11
V-I Curve	12
Packing Specification (5Ø - 25Ø Series)	15
Taping Specifications - 5Ø and 7Ø.....	16
Taping Specifications - 10Ø and 14Ø.....	17
Taping Specifications - 18Ø and 20Ø.....	18
Big Size Varistor - 32D Series	19
Big Size Varistor - 34mm Single Series	20
Big Size Varistor - 34mm Dual Series.....	21
Big Size Varistor - 40D Series	22
Big Size Varistor - 53D Series	23
V-I Curve	25

■ HOW TO ORDER

SR	241	K	10	D	S	40	X
Type code	Varistor Voltage	Tolerance	Disk Size Code	Disk Type	Lead Type or Taping Code	Lead Cutting	Special Request
SR: Walsin Varistor	(DC volt) (From 180 to 112) Two significant digits Followed by no. of zeros 180=18volt 101=100volt 102=1000volt	J: +/-5% K: +/-10%	05 : 5mm 07 : 7mm 10 : 10mm 14 : 14mm 18 : 18mm 20 : 20mm 25 : 25mm	D : Standard disk type E : High energy disk type	For bulk packing: S : Straight Lead L : Inline Crimped O : Outward Crimped I : Inward Crimped T** : Taping Code Please refer to page 15~18 for taping details.	Lead Cutting for Bulk Packing: 40=4.0±1.0mm 65=6.5±1.0mm P1=11±1.0mm No code ≥ 25mm	<ul style="list-style-type: none"> Special lead cutting tolerance Special lead spacing (Please see below) Special varistor voltage range...etc

* If customers have no special request on lead shape, we provide straight lead for voltage type ≤ 471K and in-line crimped lead for voltage type ≥ 511K.

■ VARISTOR SPECIAL REQUEST

F: 0.5mm lead length tolerance for short lead cutting (exclude straight lead)
 X: 7.5mm lead spacing for 20D and 20E (lead wire is 0.8mm diameter)
 Z: 5mm lead spacing for 10D(E), 14D(E)
 H: Special request

■ VARISTOR PART NUMBER EXAMPLES :

- Ex.1. SR241K07DT14: 7mm, 241K, inward crimped lead and reel taped.
 Ex.2. SR361K10DI45: 10mm, 361K, bulk packing, inward crimped lead, lead cutting length 4.5 ±1.0mm
 Ex.3. SR621K20EOP2: 20mm, 621K, high energy, bulk, outward crimped lead, lead spacing 12mm±1.0mm.
 Ex.4. SR271K20DO65X: 20mm, 271K, bulk, outward crimped lead, lead spacing 7.5 mm, lead cutting 6.5 ± 1.0mm
 Ex.5. SR241K10DS40F: 10mm, 241K, bulk, straight lead, lead cutting 4.0 ± 0.5mm.

■ DIMENSIONS QUICK REFERENCE : If specific item's dimensions, please contact sales

Series	5D,5E	7D,7E	10D,10E	14D,14E	18E	20D,20E	25D
Dmax	7.0	9.5	14.0	17.5	21.0	24.0	28.5
d*	0.6	0.6	0.8	0.8	0.8	1.0	1.0
W**	5.0	5.0	7.5	7.5	7.5	10.0	12.7
Hmax	12.5	14.5	20.0	22.5	27.5	29.5	36.5
H1max	10.0	12.0	17.0	20.5	24.0	28.0	34.0
Tmax	4.9	4.9	8.5	8.5	9.0	9.0	9.5

* ±0.02 ** ±1.0

(Unit: mm)

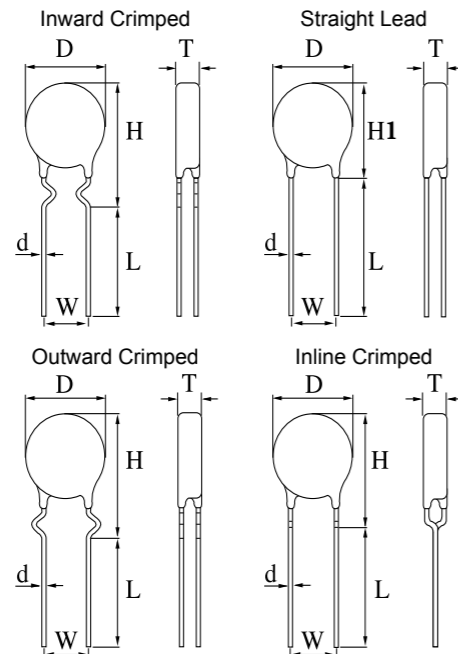

Remark:

The lead length (L) is 25mm minimum unless requested by customers; please refer to lead cutting code in "How to Order".

CHARACTERISTICS

- High performance transient voltage suppression
- Short response time to surge voltage
- Low standby power dissipation
- Excellent clamping characteristics
- High performance withstanding surge currents
- High reliability
- UL, CSA, VDE and CQC recognized

APPLICATIONS

- Surge protection in:
 - Consumer electronics
 - Industrial electronics
 - Communication electronics
 - Measuring and controlling systems
 - Electronic home appliances
- Protection against surges induced by lightning striking incoming power lines.
- Suppression of surges caused by switching inductive loads such as transformers, relays and coils.
- Protection of rectification diodes, SCRs, power transistors, semiconductor devices, etc.

DEFINITION OF VARISTOR TERMS

Rated RMS Voltage, Rated DC Voltage :

The maximum designated values of power system voltage that may be applied continuously between the terminals of a device.

Varistor Voltage :

Test characteristic that is used to classify varistors by type.

A test current of 1mA DC is typically used to determine varistor voltage classification type. Varistor voltage clamping characteristics can be defined at various test levels.

Rated Peak Single Pulse Transient Current :

Maximum surge current, 8/20 μ s waveform which a varistor is rated to withstand for a single surge.

Rated Single Pulse Transient Energy :

Maximum allowable energy for a single impulse (see specified waveforms).

Maximum Clamping Voltage :

Measured peak voltage across the device terminals when a current impulse of specified amplitude and waveform is conducted through the varistor.

Typical Capacitance :

Typical capacitance values are measured at a test frequency of 1kHz. Capacitance values are only for reference purpose only, not subject to outgoing inspection.

GENERAL CHARACTERISTICS

Storage Temperature : -55°C to +125°C

Operating Surface Temperature : 125°C

Operating Ambient Temperature : -55°C to +85°C (without derating)

Maximum Voltage-Temperature Coefficient : < -0.05% / °C

Insulation Resistance : 1000 Mega-ohm minimum

Hi Pot (Leads To Case, 1 Min.) : 2500 VDC

Typical Response Time : <15 Nano-seconds

Epoxy Rating : 94V-0

Current / Energy Derating (>85°C) : -2.5% / °C

DC Leakage Current : 200 μ A maximum (at rated DC working voltage)

Solderability : MIL-STD-202F

Power Dissipation Ratings(P, in-watts) :

Disc Size	11Vac~40Vac	50Vac~680Vac
5mm	0.01	0.15
7mm	0.02	0.25
10mm	0.05	0.4
14mm	0.1	0.6
18mm	—	0.8
20mm	0.2	1.0
25mm	—	1.2
32mm	—	1.6
34mm(single)	—	2.1
34mm(dual)	—	2.73
40mm	—	2.1
53mm	—	2.5

All definitions are according to IEEE specifications C62.33.

ENERGY DERATING VERSUS TEMPERATURE

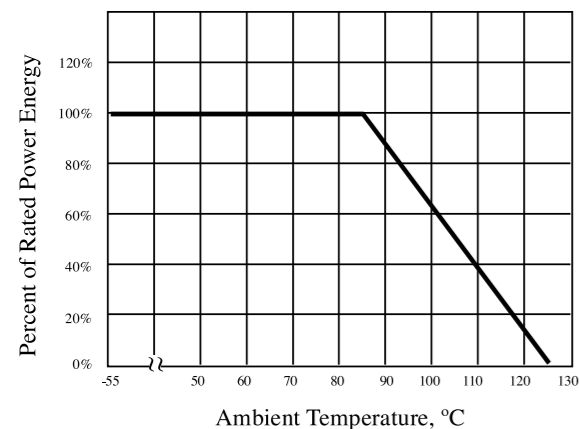

PEAK CURRENT PER PULSE VERSUS PULSE DURATION

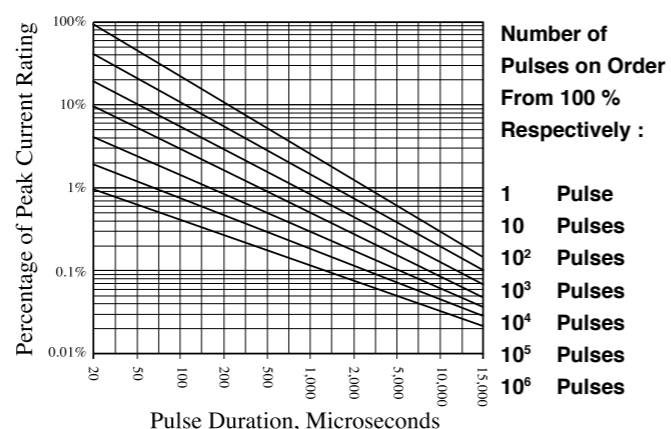

Part Number	Maximum Allowable Voltage		Varistor Voltage		Withstanding Surge Current (8/20 μ s)	Max. Clamping Voltage (8/20 μ s)		Maximum Energy		Typical Capacitance @1kHz	Safety Approval
	ACrms	DC	DC Volts			1 time	Vc	Ip	2ms		
	Volts	Volts	Min	Max	Amps	Volts	Amps	Joules		PF	
SR 180K05D □□	11	14	16	20	100	36	1	0.4	0.6	1500	○△◇
SR 220K05D □□	14	18	20	24	100	43	1	0.6	0.8	1260	○△◇
SR 270K05D □□	17	22	24	30	100	53	1	0.7	0.9	1050	○△◇
SR 330K05D □□	20	26	30	36	100	65	1	0.9	1.2	850	○△◇
SR 390K05D □□	25	31	35	43	100	77	1	1.1	1.3	600	○△◇
SR 470K05D □□	30	38	42	52	100	93	1	1.4	1.6	500	○△◇
SR 560K05D □□	35	45	50	62	100	110	1	1.5	1.9	400	○△◇
SR 680K05D □□	40	56	61	75	100	135	1	1.8	2.3	360	○△◇
SR 820K05D □□	50	66	74	90	400	135	5	2.4	3.0	350	○△◇
SR 101K05D □□	60	85	90	110	400	165	5	2.4	3.5	320	○△◇
SR 121K05D □□	75	102	108	132	400	200	5	3.0	5.0	250	○△◇
SR 151K05D □□	95	127	135	165	400	250	5	3.5	5.5	180	○△◇
SR 181K05D □□	120	160	170	207	400	320	5	4.2	8.0	155	○△★◇
SR 201K05D □□	130	175	185	225	400	340	5	5.0	8.5	140	○△□★◇
SR 221K05D □□	140	180	198	242	400	360	5	6.0	9.0	125	○△□★◇
SR 241K05D □□	150	200	216	264	400	395	5	6.5	10.0	115	○△□★◇
SR 271K05D □□	180	230	255	311	400	475	5	7.5	11.0	105	○△□★◇
SR 301K05D □□	195	250	270	330	400	525	5	8.0	11.5	95	○△□★◇
SR 331K05D □□	210	275	297	363	400	540	5	8.5	11.7	85	○△□★◇
SR 361K05D □□	230	300	324	396	400	595	5	9.0	13.0	80	○△□★◇
SR 391K05D □□	250	330	351	429	400	650	5	10	15	75	○△□★◇
SR 431K05D □□	275	370	387	473	400	710	5	11	16	65	○△□★◇
SR 471K05D □□	300	385	423	517	400	775	5	13	19	55	○△□★◇
SR 511K05D □□	320	420	459	561	400	865	5	15	21	39	○△□
SR 561K05D □□	360	470	522	638	400	960	5	17	25	36	○△□★
SR 621K05D □□	390	505	558	682	400	1040	5	19	27	33	○△□★
SR 681K05D □□	420	560	612	748	400	1120	5	21	30	30	○△□★

Remark :

1. □□: Suffix adding; please refer "How to Order" for details.
2. All parts approved as follows:
 - (1) ○ : **UL 1449** recognized (File # E172311).
 - (2) △ : **UL 497B** recognized (File # E199593).
 - (3) □ : **UL 1414** recognized (File # E182369).
 - (4) ★ : **CSA 22.2 #1** certified (File # LR109496-1 and LR109496-4).
 - (5) ◇ : **VDE/CECC 42000/42200/42201**, IEC 61051-1/61051-2/61051-2-2 (Certificate # 5932, 40010090, 40003435).
 - (6) **CQC** recognized for all part numbers (CQC04001010926).

Part Number	Maximum Allowable Voltage		Varistor Voltage		Withstanding Surge Current (8/20 μs)	Max. Clamping Voltage (8/20 μs)		Maximum Energy		Typical Capacitance @1kHz	Safety Approval
	ACrms	DC	DC Volts			1 time	Vc	Ip	2ms		
	Volts	Volts	Min	Max	Amps		Volts	Amps	Joules		
SR 180K07D □□	11	14	16	20	250	36	2.5	0.8	1.0	2900	○△◇
SR 220K07D □□	14	18	20	24	250	43	2.5	0.9	1.3	2400	○△◇
SR 270K07D □□	17	22	24	30	250	53	2.5	1.0	1.4	1800	○△◇
SR 330K07D □□	20	26	30	36	250	65	2.5	1.2	1.7	1500	○△◇
SR 390K07D □□	25	31	35	43	250	77	2.5	1.5	2.1	1230	○△◇
SR 470K07D □□	30	38	42	52	250	93	2.5	1.8	2.5	950	○△◇
SR 560K07D □□	35	45	50	62	250	110	2.5	2.2	3.1	890	○△◇
SR 680K07D □□	40	56	61	75	250	135	2.5	2.5	3.8	850	○△◇
SR 820K07D □□	50	66	74	90	1200	135	10	3.5	5.5	830	○△◇
SR 101K07D □□	60	85	90	110	1200	165	10	4.0	6.5	730	○△◇
SR 121K07D □□	75	102	108	132	1200	200	10	5.0	7.8	570	○△◇
SR 151K07D □□	95	127	135	165	1200	250	10	6.5	9.7	400	○△◇
SR 181K07D □□	120	160	170	207	1200	300	10	8.8	12.0	305	○△★◇
SR 201K07D □□	130	175	185	225	1200	340	10	10.0	13.0	275	○△□★◇
SR 221K07D □□	140	180	198	242	1200	360	10	11.0	14.0	250	○△□★◇
SR 241K07D □□	150	200	216	264	1200	395	10	11.0	16.0	230	○△□★◇
SR 271K07D □□	180	230	255	311	1200	455	10	12.0	18.0	205	○△□★◇
SR 301K07D □□	195	250	270	330	1200	505	10	13.0	19.0	185	○△□★◇
SR 331K07D □□	210	275	297	363	1200	540	10	14.0	20.0	170	○△□★◇
SR 361K07D □□	230	300	324	396	1200	595	10	15.0	25.0	155	○△□★◇
SR 391K07D □□	250	330	351	429	1200	650	10	17.0	26.0	145	○△□★◇
SR 431K07D □□	275	370	387	473	1200	710	10	20.0	28.0	130	○△□★◇
SR 471K07D □□	300	385	423	517	1200	775	10	21.0	30.0	115	○△□★◇
SR 511K07D □□	320	420	459	561	1200	850	10	23.0	32.0	88	○△□★◇
SR 561K07D □□	360	470	522	638	1200	960	10	27.0	39.0	85	○△□★◇
SR 621K07D □□	390	505	558	682	1200	1040	10	29.0	43.0	82	○△□★◇
SR 681K07D □□	420	560	612	748	1200	1120	10	32.0	45.0	78	○△□★◇

Remark :

1. □□: Suffix adding; please refer "How to Order" for details.
2. All parts approved as follows:
 - (1) ○ : **UL 1449** recognized (File # E172311).
 - (2) △ : **UL 497B** recognized (File # E199593).
 - (3) □ : **UL 1414** recognized (File # E182369).
 - (4) ★ : **CSA 22.2 #1** certified (File # LR109496-1 and LR109496-4).
 - (5) ◇ : **VDE/CECC 42000/42200/42201**, IEC 61051-1/61051-2/61051-2-2 (Certificate # 5932, 40010090, 40003435).
 - (6) **CQC** recognized for all part numbers (CQC04001010927).

Part Number	Maximum Allowable Voltage		Varistor Voltage		Withstanding Surge Current (8/20 μ s)	Max. Clamping Voltage (8/20 μ s)		Maximum Energy		Typical Capacitance @1kHz	Safety Approval
	ACrms	DC	DC Volts			1 time	Vc	Ip	2ms		
	Volts	Volts	Min	Max	Amps	Volts	Amps	Joules		PF	
SR 180K10D □□	11	14	16	20	500	36	5	1.5	2.1	6000	○△◇
SR 220K10D □□	14	18	20	24	500	43	5	2.0	2.5	5000	○△◇
SR 270K10D □□	17	22	24	30	500	53	5	2.5	3.0	4000	○△◇
SR 330K10D □□	20	26	30	36	500	65	5	3.0	4.0	3500	○△◇
SR 390K10D □□	25	31	35	43	500	77	5	3.5	4.6	3100	○△◇
SR 470K10D □□	30	38	42	52	500	93	5	4.5	5.5	2800	○△◇
SR 560K10D □□	35	45	50	62	500	110	5	5.5	7.0	2400	○△◇
SR 680K10D □□	40	56	61	75	500	135	5	6.5	8.2	2100	○△◇
SR 820K10D □□	50	66	74	90	2500	135	25	8.0	12.0	1600	○△◇
SR 101K10D □□	60	85	90	110	2500	165	25	10.0	15.0	1400	○△◇
SR 121K10D □□	75	102	108	132	2500	200	25	12.0	18.0	1200	○△◇
SR 151K10D □□	95	127	135	165	2500	250	25	16.0	22.0	1100	○△◇
SR 181K10D □□	120	160	170	207	2500	300	25	18.5	27.5	700	○△★◇
SR 201K10D □□	130	175	185	225	2500	340	25	20.0	30.0	640	○△□★◇
SR 221K10D □□	140	180	198	242	2500	360	25	23.0	32.0	600	○△□★◇
SR 241K10D □□	150	200	216	264	2500	395	25	25.0	35.0	560	○△□★◇
SR 271K10D □□	180	230	255	311	2500	455	25	30.0	40.0	500	○△□★◇
SR 301K10D □□	195	250	270	330	2500	505	25	32.0	42.5	450	○△□★◇
SR 331K10D □□	210	275	297	363	2500	540	25	33.5	44.5	415	○△□★◇
SR 361K10D □□	230	300	324	396	2500	595	25	35.0	47.0	380	○△□★◇
SR 391K10D □□	250	330	351	429	2500	650	25	40.0	60.0	350	○△□★◇
SR 431K10D □□	275	370	387	473	2500	710	25	45.0	65.0	310	○△□★◇
SR 471K10D □□	300	385	423	517	2500	775	25	46.0	70.0	280	○△□★◇
SR 511K10D □□	320	420	459	561	2500	840	25	47.0	71.0	260	○△□★◇
SR 561K10D □□	360	470	522	638	2500	910	25	48.0	72.0	240	○△□★◇
SR 621K10D □□	390	505	558	682	2500	1025	25	49.0	73.0	150	○△□★◇
SR 681K10D □□	420	560	612	748	2500	1120	25	50.0	74.0	130	○△□★◇
SR 751K10D □□	460	615	675	825	2500	1240	25	51.0	75.0	120	○△□★◇
SR 781K10D □□	485	640	702	858	2500	1290	25	52.0	80.0	120	○△□★◇
SR 821K10D □□	510	675	738	902	2500	1350	25	55.0	85.0	110	○△□★◇
SR 911K10D □□	550	745	819	1001	2500	1400	25	60.0	93.0	90	○□★◇
SR 102K10D □□	625	825	900	1100	2500	1650	25	65.0	102	80	○□★◇
SR 112K10D □□	680	895	962	1175	2500	1815	25	70.0	115	70	○□★◇

Remark :

- : Suffix adding; please refer "How to Order" for details.
- All parts approved as follows:
 - : **UL 1449** recognized (File # E172311).
 - △ : **UL 497B** recognized (File # E199593).
 - : **UL 1414** recognized (File # E182369).
 - ★ : **CSA 22.2 #1** certified (File # LR109496-1 and LR109496-4).
 - ◇ : **VDE/CECC 42000/42200/42201**, IEC 61051-1/61051-2/61051-2-2 (Certificate # 5932, 40010090, 40003435).
 - CQC** recognized for all part numbers (CQC04001010928).

Part Number	Maximum Allowable Voltage		Varistor Voltage		Withstanding Surge Current (8/20 μs)	Max. Clamping Voltage (8/20 μs)		Maximum Energy		Typical Capacitance @1kHz	Safety Approval
	ACrms	DC	DC Volts			1 time	Vc	Ip	2ms		
	Volts	Volts	Min	Max	Amps	Volts	Amps	Joules		PF	
SR 180K14D □□	11	14	16	20	1000	36	10	3.5	4.0	15000	○△◇
SR 220K14D □□	14	18	20	24	1000	43	10	4.0	5.0	12000	○△◇
SR 270K14D □□	17	22	24	30	1000	53	10	5.0	6.0	8500	○△◇
SR 330K14D □□	20	26	30	36	1000	65	10	6.0	7.5	7200	○△◇
SR 390K14D □□	25	31	35	43	1000	77	10	7.0	8.6	6300	○△◇
SR 470K14D □□	30	38	42	52	1000	93	10	8.5	10.0	5500	○△◇
SR 560K14D □□	35	45	50	62	1000	110	10	10.0	11.0	4800	○△◇
SR 680K14D □□	40	56	61	75	1000	135	10	12.0	14.0	4000	○△◇
SR 820K14D □□	50	66	74	90	4500	135	50	15.0	22.0	3300	○△◇
SR 101K14D □□	60	85	90	110	4500	165	50	20.0	30.0	2900	○△◇
SR 121K14D □□	75	102	108	132	4500	200	50	22.0	34.0	2600	○◇
SR 151K14D □□	95	127	135	165	4500	250	50	30.0	45.0	2000	○△◇
SR 181K14D □□	120	160	170	207	4500	300	50	33	53.0	1400	○△★◇
SR 201K14D □□	130	175	185	225	4500	340	50	38	60.0	1370	○△□★◇
SR 221K14D □□	140	180	198	242	4500	360	50	40	60.0	1150	○△□★◇
SR 241K14D □□	150	200	216	264	4500	395	50	45	66.0	1060	○△□★◇
SR 271K14D □□	180	230	255	311	4500	455	50	52	72.0	950	○△□★◇
SR 301K14D □□	195	250	270	330	4500	505	50	56	78.0	890	○△□★◇
SR 331K14D □□	210	275	297	363	4500	545	50	63	87.0	800	○△□★◇
SR 361K14D □□	230	300	324	396	4500	595	50	70	98.0	725	○△□★◇
SR 391K14D □□	250	330	351	429	4500	650	50	72	102	665	○△□★◇
SR 431K14D □□	275	370	387	473	4500	710	50	75	115	600	○△□★◇
SR 471K14D □□	300	385	423	517	4500	775	50	80	125	570	○△□★◇
SR 511K14D □□	320	420	459	561	4500	840	50	82	128	530	○△□★◇
SR 561K14D □□	360	470	522	638	4500	910	50	85	139	480	○△□★◇
SR 621K14D □□	390	505	558	682	4500	1025	50	88	142	270	○△□★◇
SR 681K14D □□	420	560	612	748	4500	1120	50	90	142	240	○△□★◇
SR 751K14D □□	460	615	675	825	4500	1240	50	100	143	210	○△□★◇
SR 781K14D □□	485	640	702	858	4500	1290	50	105	148	205	○△□★◇
SR 821K14D □□	510	675	738	902	4500	1350	50	110	157	200	○△□★◇
SR 911K14D □□	550	745	819	1001	4500	1400	50	120	175	175	○□★◇
SR 102K14D □□	625	825	900	1100	4500	1620	50	130	190	145	○□★◇
SR 112K14D □□	680	895	962	1175	4500	1800	50	140	215	140	○□★◇

Remark :

- : Suffix adding; please refer "How to Order" for details.
- All parts approved as follows:
 - : **UL 1449** recognized (File # E172311).
 - △ : **UL 497B** recognized (File # E199593).
 - : **UL 1414** recognized (File # E182369).
 - ★ : **CSA 22.2 #1** certified (File # LR109496-1 and LR109496-4).
 - ◇ : **VDE/CECC 42000/42200/42201**, IEC 61051-1/61051-2/61051-2-2 (Certificate # 5932, 40010090, 40003435).
 - CQC** recognized for all part numbers (CQC04001010929).

Part Number	Maximum Allowable Voltage		Varistor Voltage		Withstanding Surge Current (8/20 μ s)	Max. Clamping Voltage (8/20 μ s)		Maximum Energy		Typical Capacitance @1kHz	Safety Approval
	ACrms	DC	DC Volts			1 time	Vc	Ip	2ms		
	Volts	Volts	Min	Max	Amps	Volts	Amps	Joules		PF	
SR 180K20D □□	11	14	16	20	2000	36	20	10	12	27000	○△◇
SR 220K20D □□	14	18	20	24	2000	43	20	13	15	20000	○△◇
SR 270K20D □□	17	22	24	30	2000	53	20	15	17	15000	○△◇
SR 330K20D □□	20	26	30	36	2000	65	20	22	22	12200	○△◇
SR 390K20D □□	25	31	35	43	2000	77	20	24	26	10000	○△◇
SR 470K20D □□	30	38	42	52	2000	93	20	30	33	9350	○△◇
SR 560K20D □□	35	45	50	62	2000	110	20	35	38	8000	○△◇
SR 680K20D □□	40	56	61	75	2000	135	20	40	43	6800	○△◇
SR 820K20D □□	50	66	74	90	6500	135	100	37	48	5600	○△◇
SR 101K20D □□	60	85	90	110	6500	165	100	38	50	4700	○△◇
SR 121K20D □□	75	102	108	132	6500	200	100	40	55	4100	○△◇
SR 151K20D □□	95	127	135	165	6500	250	100	50	70	3200	○△◇
SR 181K20D □□	120	160	170	207	6500	300	100	60	85	2500	○△★◇
SR 201K20D □□	130	175	185	225	6500	340	100	70	95	2200	○△□★◇
SR 221K20D □□	140	180	198	242	6500	360	100	75	100	2000	○△□★◇
SR 241K20D □□	150	200	216	264	6500	395	100	82	110	1900	○△□★◇
SR 271K20D □□	180	230	255	311	6500	455	100	90	127	1700	○△□★◇
SR 301K20D □□	195	250	270	330	6500	505	100	100	135	1540	○△□★◇
SR 331K20D □□	210	275	297	363	6500	545	100	110	148	1400	○△□★◇
SR 361K20D □□	230	300	324	396	6500	595	100	120	163	1320	○△□★◇
SR 391K20D □□	250	330	351	429	6500	650	100	130	180	1210	○△□★◇
SR 431K20D □□	275	370	387	473	6500	710	100	140	190	1120	○△□★◇
SR 471K20D □□	300	385	423	517	6500	775	100	150	220	1000	○△□★◇
SR 511K20D □□	320	420	459	561	6500	840	100	152	222	950	○△□★◇
SR 561K20D □□	360	470	522	638	6500	910	100	154	226	900	○△□★◇
SR 621K20D □□	390	505	558	682	6500	1025	100	158	228	770	○△□★◇
SR 681K20D □□	420	560	612	748	6500	1120	100	160	230	700	○△□★◇
SR 751K20D □□	460	615	675	825	6500	1240	100	175	255	640	○△□★◇
SR 781K20D □□	485	640	702	858	6500	1290	100	180	265	590	○△□★◇
SR 821K20D □□	510	675	738	902	6500	1350	100	190	282	510	○△□★◇
SR 911K20D □□	550	745	819	1001	6500	1400	100	215	310	430	○□★◇
SR 102K20D □□	625	825	900	1100	6500	1620	100	230	342	380	○□★◇
SR 112K20D □□	680	895	962	1175	6500	1800	100	250	383	340	○□★◇

Remark :

- : Suffix adding; please refer "How to Order" for details.
- All parts approved as follows:
 - : **UL 1449** recognized (File # E172311).
 - △ : **UL 497B** recognized (File # E199593).
 - : **UL 1414** recognized (File # E182369).
 - ★ : **CSA 22.2 #1** certified (File # LR109496-1 and LR109496-4).
 - ◇ : **VDE/CECC 42000/42200/42201**, IEC 61051-1/61051-2/61051-2-2 (Certificate # 5932, 40010090, 40003435).
 - CQC** recognized for all part numbers (CQC04001010931).

Part Number	Maximum Allowable Voltage		Varistor Voltage		Withstanding Surge Current (8/20 μ s)	Max. Clamping Voltage (8/20 μ s)		Maximum Energy		Typical Capacitance @1kHz	Safety Approval	
	ACrms	DC	DC Volts			1 time	Vc	Ip	2ms			
	Volts	Volts	Min	Max	Amps	Volts	Amps	Joules		PF		
SR 181K25D □□	120	160	170	207	18000	300	100	90	180	3900	○	☆
SR 201K25D □□	130	175	185	225	18000	340	100	100	200	3600	○	☆
SR 221K25D □□	140	180	198	242	18000	360	100	105	225	3300	○	☆
SR 241K25D □□	150	200	216	264	18000	395	100	110	235	3050	○	☆
SR 271K25D □□	180	230	255	311	18000	455	100	120	245	2600	○	☆
SR 301K25D □□	195	250	270	330	18000	505	100	125	255	2400	○	☆
SR 331K25D □□	210	275	297	363	18000	545	100	130	270	2200	○	☆
SR 361K25D □□	230	300	324	396	18000	595	100	160	315	2050	○	☆
SR 391K25D □□	250	330	351	429	18000	650	100	175	342	1900	○	☆
SR 431K25D □□	275	370	387	473	18000	710	100	190	370	1700	○	☆
SR 471K25D □□	300	385	423	517	18000	775	100	200	390	1600	○	☆
SR 511K25D □□	320	420	459	561	18000	840	100	210	422	1400	○	☆
SR 561K25D □□	360	470	522	638	18000	910	100	215	460	1200	○	☆
SR 621K25D □□	390	505	558	682	18000	1025	100	225	495	1800	○	☆
SR 681K25D □□	420	560	612	748	18000	1120	100	230	515	1100	○	☆
SR 751K25D □□	460	615	675	825	18000	1240	100	250	530	1000	○	☆
SR 781K25D □□	485	640	702	858	18000	1290	100	260	540	980	○	☆
SR 821K25D □□	510	675	738	902	18000	1350	100	270	550	920	○	☆
SR 911K25D □□	550	745	819	1001	18000	1400	100	300	600	880	○	☆
SR 102K25D □□	625	825	900	1100	18000	1620	100	340	630	760	○	☆
SR 112K25D □□	680	895	962	1175	18000	1800	100	390	700	650	○	☆

Remark :

1. □□: Suffix adding; please refer “How to Order” for details.
2. All parts approved as follows:
 - (1) ○ : **UL 1449** recognized (File # E172311).
 - (2) △ : **UL 497B** recognized (File # E199593).
 - (3) □ : **UL 1414** recognized (File # E182369).
 - (4) ☆ : **CSA 22.2 #1** certified (File # LR109496-1 and LR109496-4).
 - (5) ◇ : **VDE/CECC 42000/42200/42201**, IEC 61051-1/61051-2/61051-2-2 (Certificate # 5932, 40010090, 40003435).
 - (6) **CQC** recognized for all part numbers (CQC04001010932).

Part Number	Maximum Allowable Voltage		Varistor Voltage		Withstanding Surge Current (8/20 μs)	Max. Clamping Voltage (8/20 μs)		Maximum Energy	Typical Capacitance	Safety Approval
	ACrms	DC	DC Volts		1 time	Vc	Ip	10/1000μs	@1kHz	
	Volts	Volts	Min	Max	Amps	Volts	Amps	Joules	PF	
SR 820K05E □□	50	66	74	90	800	135	5	3.5	355	○△
SR 181K05E □□	120	160	170	207	800	320	5	8.0	130	○
SR 201K05E □□	130	175	185	225	800	340	5	8.5	120	○△□☆
SR 221K05E □□	140	180	198	242	800	360	5	9.0	110	○△□☆
SR 241K05E □□	150	200	216	264	800	395	5	10.5	100	○△□☆
SR 271K05E □□	180	230	255	311	800	475	5	11.0	90	○△□☆
SR 301K05E □□	195	250	270	330	800	525	5	12.0	84	□
SR 331K05E □□	210	275	297	363	800	540	5	13.0	75	○△□☆
SR 361K05E □□	230	300	324	396	800	595	5	16.0	69	○ □☆
SR 391K05E □□	250	330	351	429	800	650	5	17.0	63	○ □☆
SR 431K05E □□	275	370	387	473	800	710	5	20.0	57	○ □☆
SR 471K05E □□	300	385	423	517	800	775	5	21.0	50	○△□☆
SR 511K05E □□	320	420	459	561	800	865	5	22.0	35	□
SR 561K05E □□	360	470	522	638	800	960	5	23.0	32	□
SR 621K05E □□	390	505	558	682	800	1040	5	25.0	30	□
SR 681K05E □□	420	560	612	748	800	1120	5	26.0	27	□

Remark :

1. □□: Suffix adding; please refer “How to Order” for details.
2. All parts approved as follows:
 - (1) ○ : **UL 1449** recognized (File # E172311).
 - (2) △ : **UL 497B** recognized (File # E199593).
 - (3) □ : **UL 1414** recognized (File # E182369).
 - (4) ☆ : **CSA 22.2 #1** certified (Certificate # 1129226).
 - (5) ◇ : **VDE/CECC 42000/42200/42201** (Certificate # 40003435). VDE approval of 05E and 20E series is pending.
 - (6) **CQC** recognized for all E Series (CQC04001010926 ~ CQC04001010932).

Part Number	Maximum Allowable Voltage		Varistor Voltage		Withstanding Surge Current (8/20 μs)	Max. Clamping Voltage (8/20 μs)		Maximum Energy	Typical Capacitance	Safety Approval
	ACrms	DC	DC Volts		1 time	Vc	Ip	10/1000μs	@1kHz	
	Volts	Volts	Min	Max	Amps	Volts	Amps	Joules	PF	
SR 820K07E □□	50	66	74	90	1750	135	10	7.0	790	○△ ◇
SR 181K07E □□	120	160	170	207	1750	320	10	16.0	210	○ ◇
SR 201K07E □□	130	175	185	225	1750	340	10	17.5	200	○△□☆◇
SR 221K07E □□	140	180	198	242	1750	360	10	19.0	190	○△□☆◇
SR 241K07E □□	150	200	216	264	1750	395	10	21.0	170	○△□☆◇
SR 271K07E □□	180	230	255	311	1750	475	10	24.0	150	○△□☆◇
SR 301K07E □□	195	250	270	330	1750	525	10	26.0	140	□ ◇
SR 331K07E □□	210	275	297	363	1750	540	10	28.0	130	○△□☆◇
SR 361K07E □□	230	300	324	396	1750	595	10	32.0	123	○ □☆◇
SR 391K07E □□	250	330	351	429	1750	650	10	35.0	116	○ □☆◇
SR 431K07E □□	275	370	387	473	1750	710	10	40.0	108	○ □☆◇
SR 471K07E □□	300	385	423	517	1750	775	10	42.0	100	○△□☆◇
SR 511K07E □□	320	420	459	561	1750	850	10	46.0	78	□ ◇
SR 561K07E □□	360	470	522	638	1750	960	10	47.0	75	□ ◇
SR 621K07E □□	390	505	558	682	1750	1040	10	51.0	72	□ ◇
SR 681K07E □□	420	560	612	748	1750	1120	10	57.0	69	□ ◇

1. □□: Suffix adding; please refer “How to Order” for details.
2. Safety approval: please refer to “Remark” above.

Part Number	Maximum Allowable Voltage		Varistor Voltage		Withstanding Surge Current (8/20 μs)	Max. Clamping Voltage (8/20 μs)		Maximum Energy	Typical Capacitance	Safety Approval
	ACrms	DC	DC Volts		1 time	Vc	Ip	10/1000μs	@1kHz	
	Volts	Volts	Min	Max	Amps	Volts	Amps	Joules	PF	
SR 820K10E □□	50	66	74	90	3500	135	25	14.0	1780	○△◇
SR 181K10E □□	120	160	170	207	3500	320	25	33.0	460	○◇
SR 201K10E □□	130	175	185	225	3500	340	25	35.0	430	○△□☆◇
SR 221K10E □□	140	180	198	242	3500	360	25	39.0	410	○△□☆◇
SR 241K10E □□	150	200	216	264	3500	395	25	42.0	380	○△□☆◇
SR 271K10E □□	180	230	255	311	3500	450	25	49.0	350	○△□☆◇
SR 301K10E □□	195	250	270	330	3500	505	25	53.0	320	□◇
SR 331K10E □□	210	275	297	363	3500	540	25	58.0	300	○△□☆◇
SR 361K10E □□	230	300	324	396	3500	595	25	65.0	285	○□☆◇
SR 391K10E □□	250	330	351	429	3500	650	25	70.0	270	○□☆◇
SR 431K10E □□	275	370	387	473	3500	710	25	80.0	255	○□☆◇
SR 471K10E □□	300	385	423	517	3500	775	25	85.0	230	○△□☆◇
SR 511K10E □□	320	420	459	561	3500	840	25	92.0	210	○△□☆◇
SR 561K10E □□	360	470	522	638	3500	910	25	97.0	170	○□☆◇
SR 621K10E □□	390	505	558	682	3500	1025	25	107.0	146	□☆◇
SR 681K10E □□	420	560	612	748	3500	1120	25	110.0	136	□☆◇
SR 751K10E □□	460	615	675	825	3500	1240	25	115.0	124	□☆◇
SR 781K10E □□	485	640	702	858	3500	1290	25	120.0	120	□☆◇
SR 821K10E □□	510	675	738	902	3500	1350	25	125.0	110	○△□☆◇
SR 911K10E □□	550	745	819	1001	3500	1400	25	130.0	90	○□◇
SR 102K10E □□	625	725	900	1100	3500	1620	25	145.0	80	□◇
SR 112K10E □□	680	895	962	1175	3500	1815	25	155.0	70	○□◇

1. □□: Suffix adding; please refer "How to Order" for details.

2. Safety approval: please refer to "Remark" on page 9.

Part Number	Maximum Allowable Voltage		Varistor Voltage		Withstanding Surge Current (8/20 μs)	Max. Clamping Voltage (8/20 μs)		Maximum Energy	Typical Capacitance	Safety Approval
	ACrms	DC	DC Volts		1 time	Vc	Ip	10/1000μs	@1kHz	
	Volts	Volts	Min	Max	Amps	Volts	Amps	Joules	PF	
SR 820K14E □□	50	66	74	90	6000	135	50	28.0	3310	○△◇
SR 181K14E □□	120	160	170	207	6000	320	50	56.0	800	○◇
SR 201K14E □□	130	175	185	225	6000	330	50	70.0	770	○△□☆◇
SR 221K14E □□	140	180	198	242	6000	360	50	78.0	740	○△□☆◇
SR 241K14E □□	150	200	216	264	6000	395	50	84.0	700	○△□☆◇
SR 271K14E □□	180	230	255	311	6000	450	50	99.0	640	○△□☆◇
SR 301K14E □□	195	250	270	330	6000	505	50	107.0	620	□◇
SR 331K14E □□	210	275	297	363	6000	545	50	115.0	580	○△□☆◇
SR 361K14E □□	230	300	324	396	6000	595	50	140.0	540	○□☆◇
SR 391K14E □□	250	330	351	429	6000	650	50	150.0	500	○□☆◇
SR 431K14E □□	275	370	387	473	6000	710	50	165.0	460	○□☆◇
SR 471K14E □□	300	385	423	517	6000	775	50	175.0	400	○△□☆◇
SR 511K14E □□	320	420	459	561	6000	840	50	190.0	350	○△□☆◇
SR 561K14E □□	360	470	522	638	6000	910	50	210.0	320	○□☆◇
SR 621K14E □□	390	505	558	682	6000	1025	50	215.0	270	□☆◇
SR 681K14E □□	420	560	612	748	6000	1120	50	225.0	250	□☆◇
SR 751K14E □□	460	615	675	825	6000	1240	50	230.0	230	□☆◇
SR 781K14E □□	485	640	702	858	6000	1290	50	235.0	210	□☆◇
SR 821K14E □□	510	675	738	902	6000	1350	50	240.0	190	○△□☆◇
SR 911K14E □□	550	745	819	1001	6000	1400	50	255.0	170	○□◇
SR 102K14E □□	625	725	900	1100	6000	1620	50	290.0	165	□◇
SR 112K14E □□	680	895	962	1175	6000	1800	50	310.0	140	○□◇

1. □□: Suffix adding; please refer "How to Order" for details.

2. Safety approval: please refer to "Remark" on page 9.

Part Number	Maximum Allowable Voltage		Varistor Voltage		Withstanding Surge Current (8/20 μ s)	Max. Clamping Voltage (8/20 μ s)		Maximum Energy	Typical Capacitance	Safety Approval
	ACrms	DC	DC Volts		1 time	Vc	Ip	10/1000 μ s	@1kHz	
	Volts	Volts	Min	Max	Amps	Volts	Amps	Joules	PF	
SR 820K18E □□	50	66	74	90	8000	135	75	46	3500	○ ◇
SR 181K18E □□	120	160	170	207	9000	320	75	70	1600	○ ◇
SR 201K18E □□	130	175	185	225	9000	340	75	130	1270	○△□☆◇
SR 221K18E □□	140	180	198	242	9000	360	75	135	1220	○△□☆◇
SR 241K18E □□	150	200	216	264	9000	395	75	140	1200	○△□☆◇
SR 271K18E □□	180	230	255	311	9000	455	75	150	1050	○△□☆◇
SR 301K18E □□	195	250	270	330	9000	505	75	170	1010	□☆◇
SR 331K18E □□	210	275	297	363	9000	545	75	190	950	○△□☆◇
SR 361K18E □□	230	300	324	396	9000	595	75	215	870	○△□☆◇
SR 391K18E □□	250	330	351	429	9000	650	75	240	800	○△□☆◇
SR 431K18E □□	275	370	387	473	9000	710	75	260	730	○△□☆◇
SR 471K18E □□	300	385	423	517	9000	775	75	290	660	○△□☆◇
SR 511K18E □□	320	420	459	561	9000	840	75	314	570	○△□☆◇
SR 561K18E □□	360	470	522	638	9000	910	75	320	520	○△□☆◇
SR 621K18E □□	390	505	558	682	9000	1025	75	330	470	○△□☆◇
SR 681K18E □□	420	560	612	748	9000	1120	75	340	430	○△□☆◇
SR 751K18E □□	460	615	675	825	9000	1240	75	360	390	○△□☆◇
SR 781K18E □□	485	640	702	858	9000	1290	75	365	370	○△□☆◇
SR 821K18E □□	510	675	738	902	9000	1350	75	388	310	○△□☆◇
SR 911K18E □□	550	745	819	1001	9000	1400	75	405	280	○ □☆◇
SR 102K18E □□	625	725	900	1100	9000	1620	75	450	250	○ □☆◇
SR 112K18E □□	680	895	962	1175	9000	1800	75	500	230	○ □☆◇

1. □□: Suffix adding; please refer "How to Order" for details.

2. Safety approval: please refer to "Remark" on page 9.

Part Number	Maximum Allowable Voltage		Varistor Voltage		Withstanding Surge Current (8/20 μ s)	Max. Clamping Voltage (8/20 μ s)		Maximum Energy	Typical Capacitance	Safety Approval
	ACrms	DC	DC Volts		1 time	Vc	Ip	10/1000 μ s	@1kHz	
	Volts	Volts	Min	Max	Amps	Volts	Amps	Joules	PF	
SR 820K20E □□	50	66	74	90	10000	135	100	56	5300	○△
SR 181K20E □□	120	160	170	207	12000	320	100	135	1800	○
SR 201K20E □□	130	175	185	225	12000	340	100	140	1700	○△□
SR 221K20E □□	140	180	198	242	12000	360	100	155	1600	○△□☆
SR 241K20E □□	150	200	216	264	12000	395	100	170	1500	○△□☆
SR 271K20E □□	180	230	255	311	12000	455	100	190	1300	○△□☆
SR 301K20E □□	195	250	270	330	12000	505	100	210	1200	○ □☆
SR 331K20E □□	210	275	297	363	12000	545	100	228	1100	○△□☆
SR 361K20E □□	230	300	324	396	12000	595	100	275	1050	○ □☆
SR 391K20E □□	250	330	351	429	12000	650	100	305	1000	○ □☆
SR 431K20E □□	275	370	387	473	12000	710	100	330	950	○ □☆
SR 471K20E □□	300	385	423	517	12000	775	100	350	900	○△□☆
SR 511K20E □□	320	420	459	561	12000	840	100	382	800	○△□☆
SR 561K20E □□	360	470	522	638	12000	910	100	395	760	○ □☆
SR 621K20E □□	390	505	558	682	12000	1025	100	410	710	○ □☆
SR 681K20E □□	420	560	612	748	12000	1120	100	423	670	○ □☆
SR 751K20E □□	460	615	675	825	12000	1240	100	435	620	○ □☆
SR 781K20E □□	485	640	702	858	12000	1240	100	450	580	○ □☆
SR 821K20E □□	510	675	738	902	12000	1350	100	460	530	○△□☆
SR 911K20E □□	550	745	819	1001	12000	1400	100	510	470	○ □☆
SR 102K20E □□	625	725	900	1100	12000	1620	100	560	425	○ □☆
SR 112K20E □□	680	895	962	1175	12000	1800	100	620	380	○ □☆

1. □□: Suffix adding; please refer "How to Order" for details.

2. Safety approval: please refer to "Remark" on page 9.

V-I Curve for SR180K~680K05D(E) Series

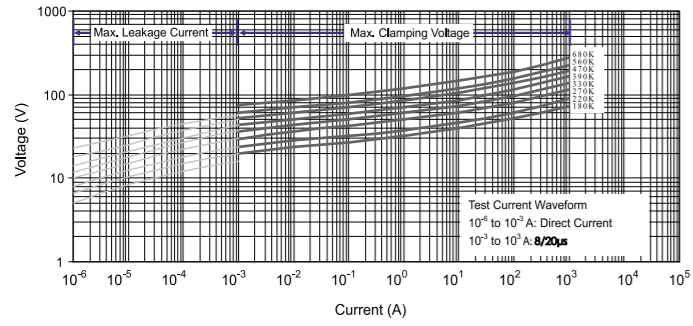

V-I Curve for SR180K~680K07D(E) Series

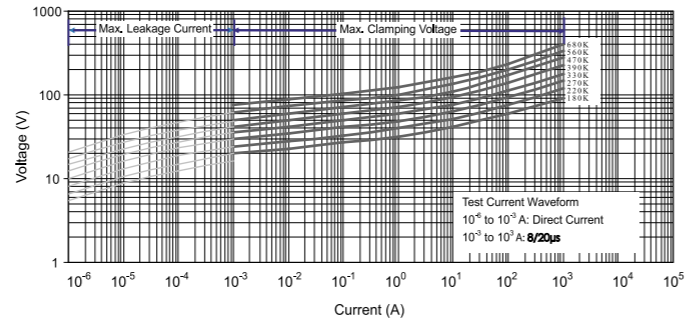

V-I Curve for SR820K~431K05D(E) Series

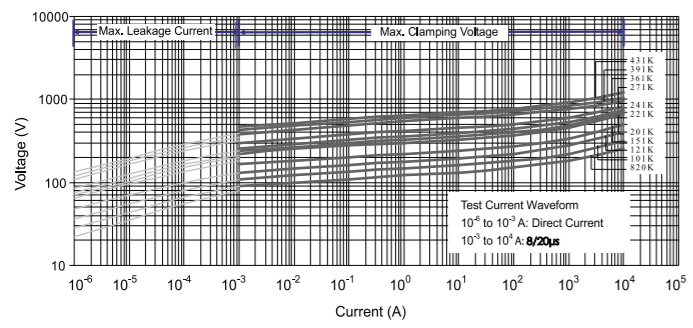

V-I Curve for SR820K~431K07D(E) Series

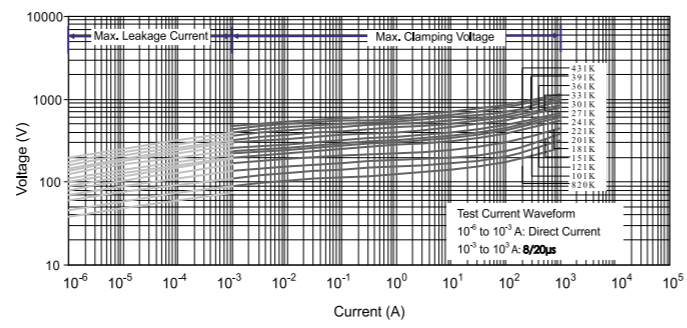

V-I Curve for SR471K~561K05D(E) Series

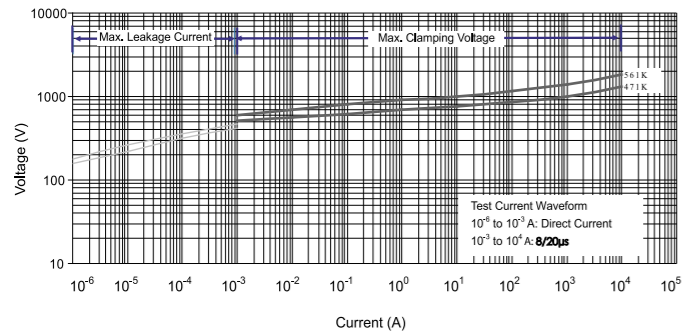

V-I Curve for SR471K~561K07D(E) Series

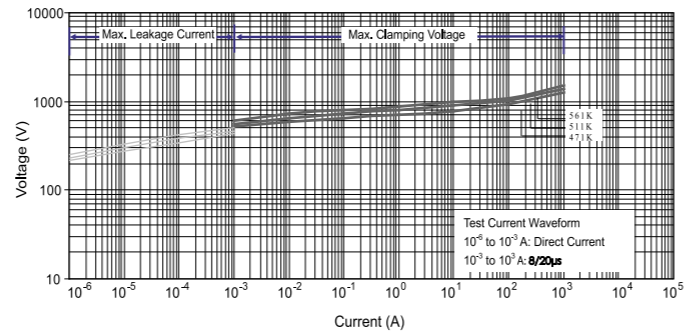

V-I Curve for SR180K~680K10D(E) Series

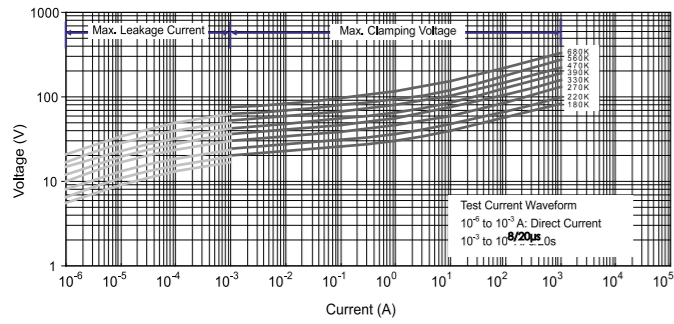

V-I Curve for SR180K ~ 680K14D(E) Series

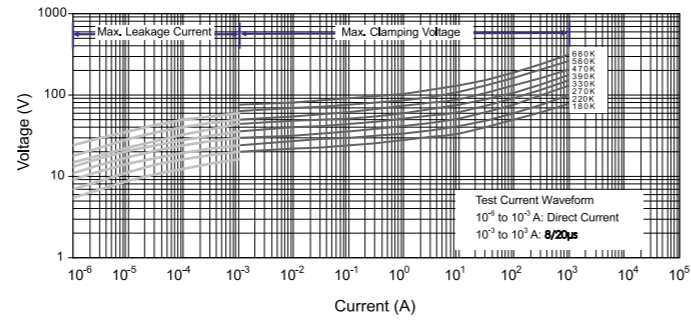

V-I Curve for SR820K ~ 431K10D(E) Series

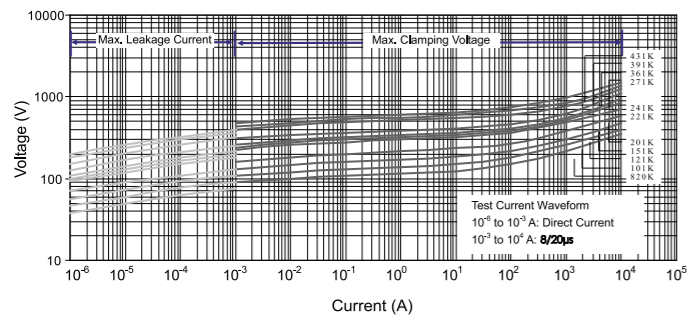

V-I Curve for SR820K~431K14D(E) Series

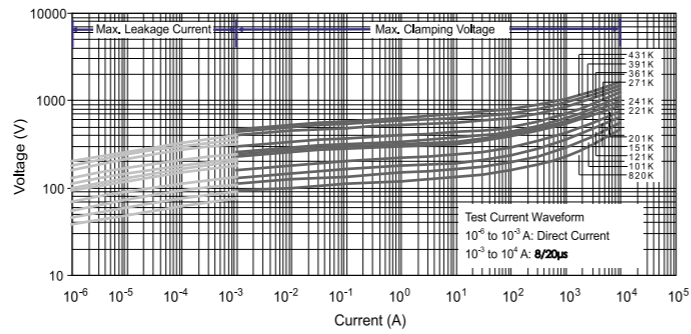

V-I Curve for 471K~112K10D (E) Series

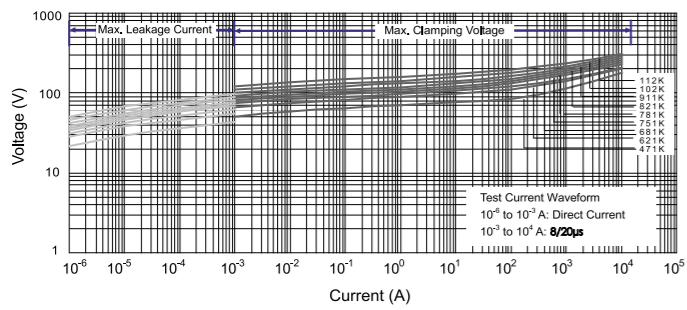

V-I Curve for SR471K ~ 112K14D(E) Series

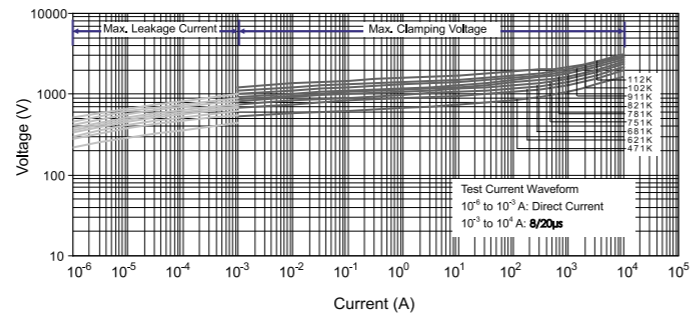

V-I Curve for SR820K~ 431K18E Series

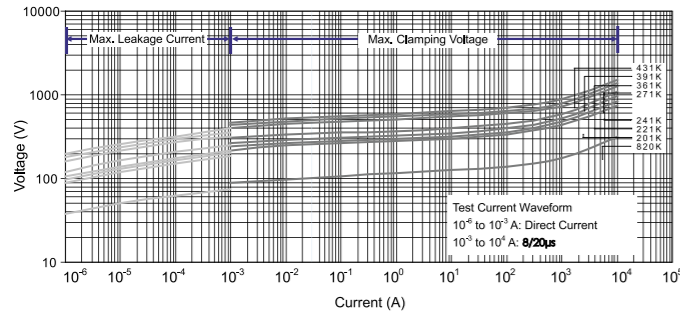

V-I Curve for SR820K~ 431K20DE Series

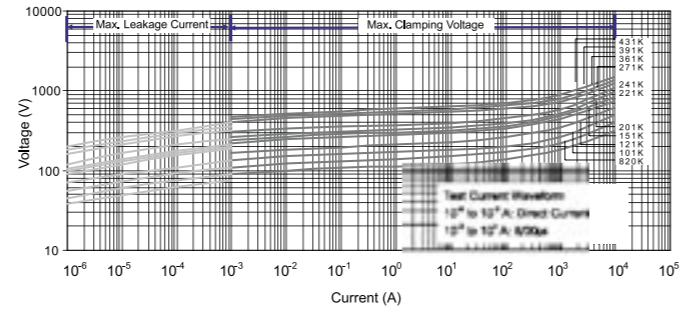

V-I Curve for SR471K~ 112K18E Series

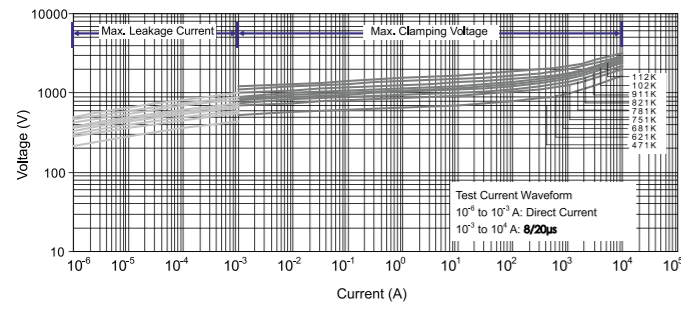

V-I Curve for SR471K~ 112K20D(E) Series

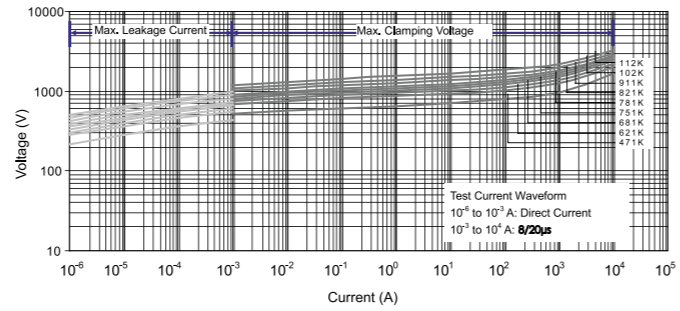

V-I Curve for SR201K~ 431K25D Series

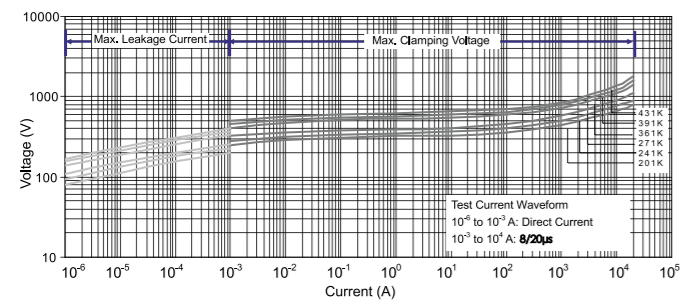

V-I Curve for SR471K~ 951K25D Series

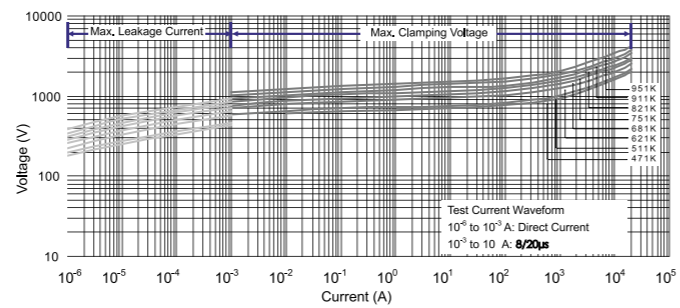

A. Bulk Packing :

Disk size mm	Voltage BDV	Q'ty pcs/bag	Q'ty pcs/Carton
Diameter 05	All	1000	10000
Diameter 07	All	500	5000
Diameter 10	180K-471K	500	5000
	Above 511K	300	3000
Diameter 14	180K-751K	300	3000
	Above 781K	200	2000
Diameter 18	All	200	2000
Diameter 20	180K-621K	100	1000
	Above 681K	50	500
Diameter 25	180K-621K	50	500
	Above 681K	30	300

Carton size of bulk packing

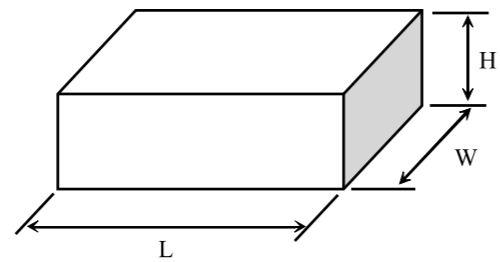

L approx. 395mm
W approx. 285mm
H approx. 180mm

B. Taping Packing :

Disk size	Varistor Voltage	AMMO BOX		REEL		
		PCS / BOX	BOX / CARTON	PCS / REEL	REELS / BOX	BOX / CARTON
5Ø	≤ 431K	1500	10	1500	2	5
5Ø	≥ 471K	1000	10	1000	2	5
7Ø	≤ 431K	1500	10	1500	2	5
7Ø	≥ 471K	1000	10	1000	2	5
10Ø	≤ 431K	500	10	500	2	5
10Ø	≥ 471K	300	10	300	2	5
14Ø	≤ 431K	500	8	500	2	5
14Ø	≥ 471K	300	8	300	2	5
18Ø	≤ 431K	500	8	500	2	5
18Ø	≥ 471K	300	8	300	2	5
20Ø	≤ 431K	500	8	500	2	5
20Ø	≥ 471K	300	8	300	2	5

Note: Ammo box and reel quantity may vary. Please contact sales for details.

■ Dimensions of Ammo Box and Reel :

Ammo Dimension

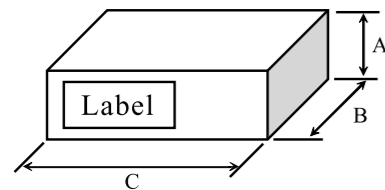

Disk size	A (max.)	B (max.)	C (max.)
5Ø	60 mm	250 mm	340 mm
7Ø	60 mm	250 mm	340 mm
10Ø	60 mm	250 mm	340 mm
14Ø	60 mm	250 mm	340 mm
18Ø, 20Ø	60 mm	250 mm	340 mm

Reel Dimension

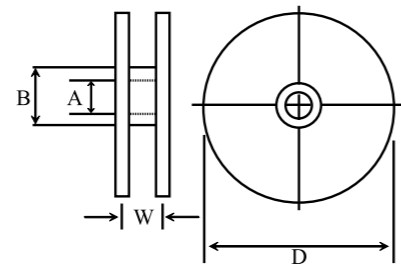

W approx. 50mm
D 350Ø max
A approx. 30Ø
B approx. 95Ø

■ Taping Code :

Varistor series	Lead spacing	Packing type	Lead type			
			Straight	Outward crimped	Inward crimped	Inline crimped
5D, 5E	5 mm	Ammo Reel	T11	T17	T1D	T1W
			T1	T3	T14	T32
7D, 7E	5 mm	Ammo Reel	T11	T17	T1D	T1W
			T1	T3	T14	T32
10D, 10E	7.5 mm	Ammo Reel	T36	T1U	T8	T43
			T19	T1N	T16	T4
14D, 14E	7.5 mm	Ammo Reel	T36	T1U	T8	T43
			T19	T1N	T16	T4
18E	7.5 mm	Ammo Reel	T44	T45	T40	T2
			T1H	T1X	T4X	T25
20D, 20E	10 mm	Ammo Reel	T5	T50	T35	T60
			T30	T2X	T2D	T3X

T11(Ammo Box)
T1(Reel)

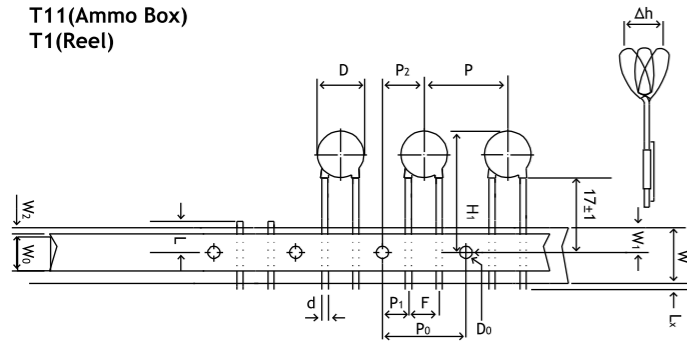

T17(Ammo Box)
T3(Reel)

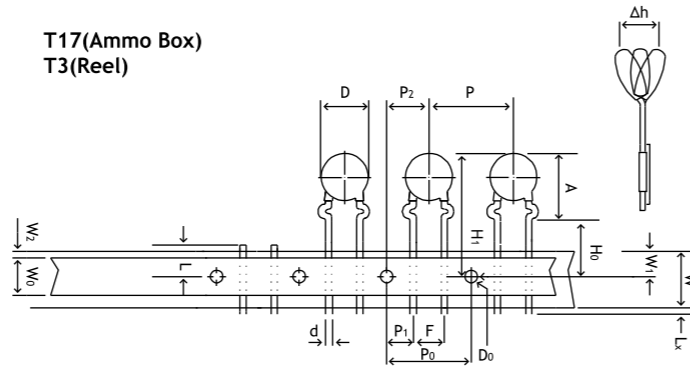

T1D(Ammo Box)
T14(Reel)

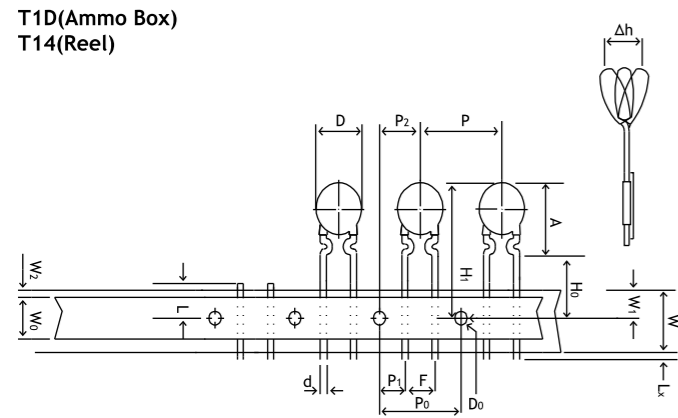

T1W(Ammo Box)
T32(Reel)

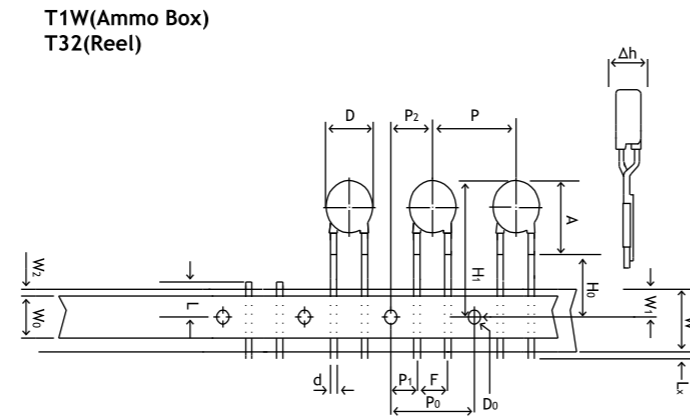

Item	Disk Size					
	5Ø (5D, 5E)			7Ø (7D, 7E)		
Taping Code	T11, T1	T17, T3, T14, T1D	T32, T1W	T11, T1	T17, T3, T14, T1D	T32, T1W
Body Diameter	D	7Max	7Max	7Max	9Max	9Max
Lead Wire Diameter	d	0.6	0.6	0.6	0.6	0.6
Pitch of Component	P	12.7 ± 1	12.7 ± 1	12.7 ± 1	12.7 ± 1	12.7 ± 1
Feed Hole Pitch	P ₀	12.7 ± 0.3	12.7 ± 0.3	12.7 ± 0.3	12.7 ± 0.3	12.7 ± 0.3
Feed Hole Center to Lead	P ₁	3.85 ± 0.7	3.85 ± 0.7	3.85 ± 0.7	3.85 ± 0.7	3.85 ± 0.7
Lead to Lead Distance (Center to Center)	F	5.0 ± 0.8	5.0 ± 0.8	5.0 ± 0.8	5.0 ± 0.8	5.0 ± 0.8
Component Alignment	Δh	2.0Max	2.0Max	2.0Max	2.0Max	2.0Max
Base paper Tape Width	W	18*	18*	18*	18*	18*
Adhesive Tape Width	W ₀	10Min	10Min	10Min	10Min	10Min
Hole Position	W ₁	9 ± 0.5	9 ± 0.5	9 ± 0.5	9 ± 0.5	9 ± 0.5
Adhesive Tape Border	W ₂	1.5Max	1.5Max	1.5Max	1.5Max	1.5Max
Component Height	H ₁	30Max	30Max	30Max	32Max	32Max
Lead-Wire Clinch Height	H ₀	-	16 ± 0.5	16 ± 0.5	-	16 ± 0.5
Lead-Wire Protrusion	L _x	1.0Max	1.0Max	1.0Max	1.0Max	1.0Max
Feed Hole Diameter	D ₀	4 ± 0.2	4 ± 0.2	4 ± 0.2	4 ± 0.2	4 ± 0.2
Total Tape Thickness	t	< 0.7	< 0.7	< 0.7	< 0.7	< 0.7
Length of Clipped Lead	L	11Max	11Max	11Max	11Max	11Max
Component Height from Seating Plane	A	-	13Max	13Max	-	15Max
Hole Center to Component Center	P ₂	6.35 ± 0.7	6.35 ± 0.7	6.35 ± 0.7	6.35 ± 0.7	6.35 ± 0.7

Based on EIA-468-B Specification
All dimensions are in millimeters.

* Tolerances are +1.0 and -0.5

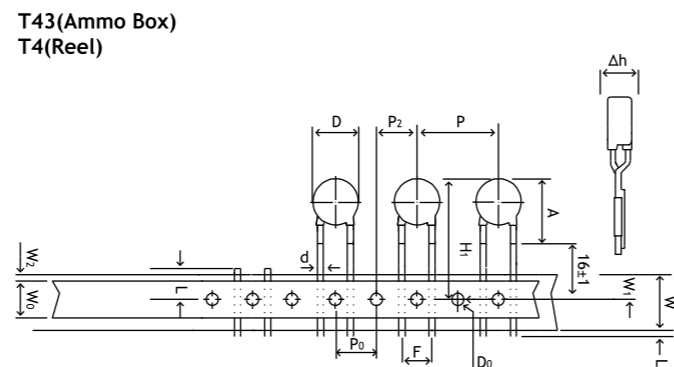
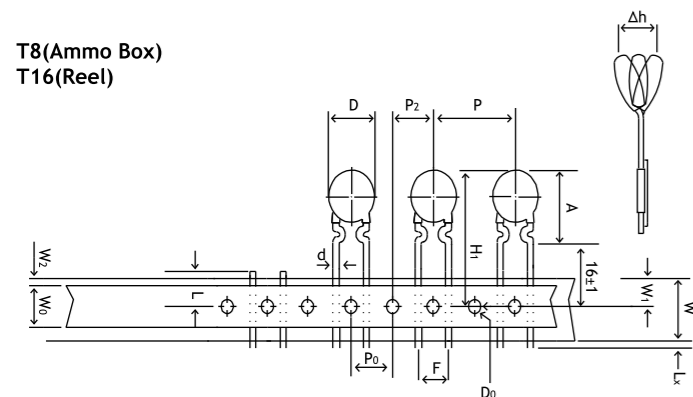
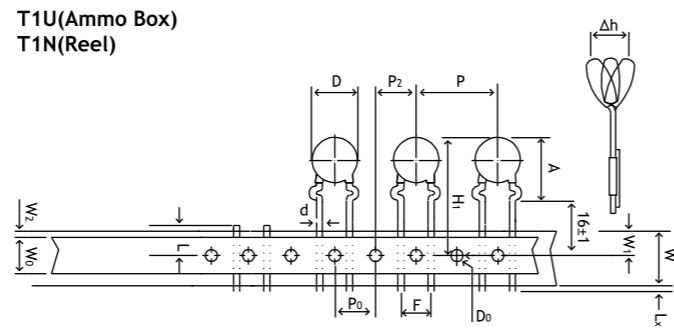
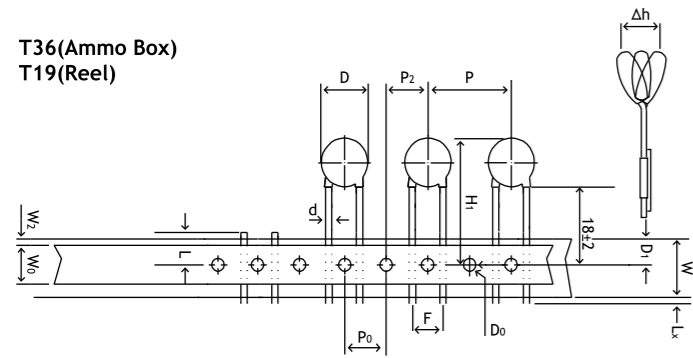

Item	Disk Size					
	10Ø (10D, 10E)			14Ø (14D, 14E)		
Taping Code	T19, T36	T1N, T1U, T8, T16	T43, T4	T19, T36	T1N, T1U, T8, T16	T43, T4
Body Diameter	D	14Max	14Max	14Max	17.5Max	17.5Max
Lead Wire Diameter	d	0.8 ± 0.05	0.8 ± 0.05	0.8 ± 0.05	0.8 ± 0.05	0.8 ± 0.05
Pitch of Component	P	25.4 ± 1	25.4 ± 1	25.4 ± 1	25.4 ± 1	25.4 ± 1
Hole Center to Component Center	P ₂	12.7 ± 0.3	12.7 ± 0.3	12.7 ± 0.3	12.7 ± 0.3	12.7 ± 0.3
Feed Hole Pitch	P ₀	12.7 ± 0.3	12.7 ± 0.3	12.7 ± 0.3	12.7 ± 0.3	12.7 ± 0.3
Lead to Lead Distance (Center to Center)	F	7.5 ± 0.8	7.5 ± 0.8	7.5 ± 0.8	7.5 ± 0.8	7.5 ± 0.8
Component Alignment	Δh	2.0Max	2.0Max	2.0Max	2.0Max	2.0Max
Base paper Tape Width	W	18*	18*	18*	18*	18*
Adhesive Tape Width	W ₀	10Min	10Min	10Min	10Min	10Min
Hole Position	W ₁	9 ± 0.5	9 ± 0.5	9 ± 0.5	9 ± 0.5	9 ± 0.5
Adhesive Tape Border	W ₂	1.5Max	1.5Max	1.5Max	1.5Max	1.5Max
Component Height	H ₁	33Max	38.5Max	35.5Max	37Max	40Max
Lead-Wire Protrusion	L _x	1.0Max	1.0Max	1.0Max	1.0Max	1.0Max
Feed Hole Diameter	D ₀	4 ± 0.2	4 ± 0.2	4 ± 0.2	4 ± 0.2	4 ± 0.2
Total Tape Thickness	t	< 0.7	< 0.7	< 0.7	< 0.7	< 0.7
Length of Clipped Lead	L	11Max	11Max	11Max	11Max	11Max
Component Height from Seating Plane	A	-	19.5Max	19.5Max	-	22.5Max

Based on EIA-468-B Specification
All dimensions are in millimeters.

* Tolerances are +1.0 and -0.5

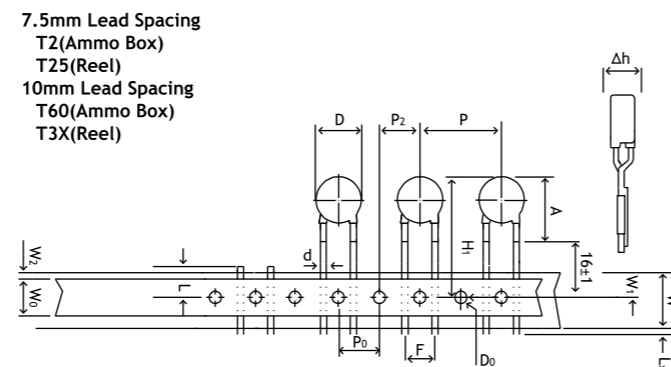
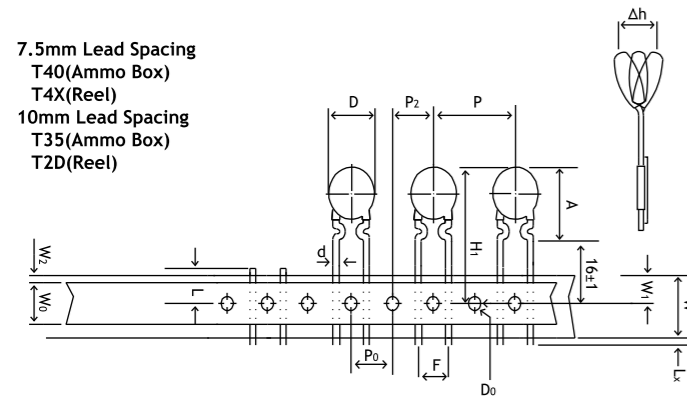
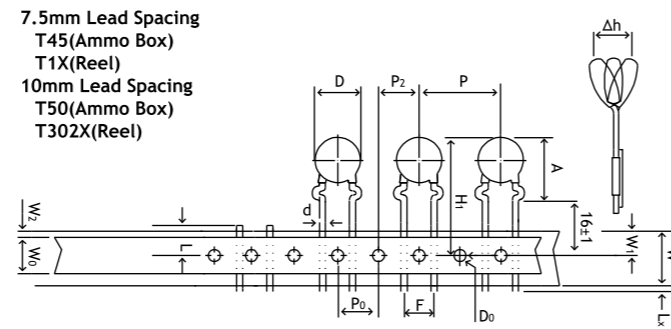
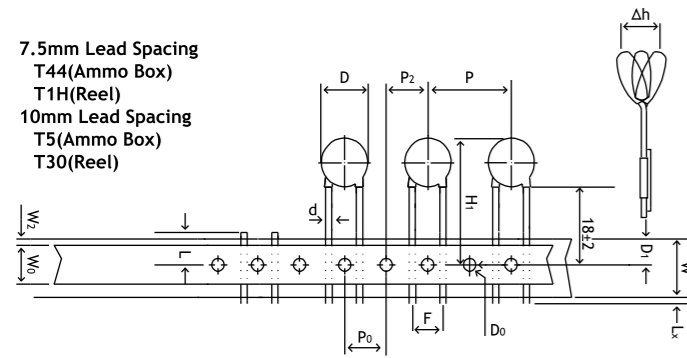

Item	Disk Size						
	20Ø (20D, 20E), 18Ø (18E)			20Ø (20D, 20E)			
	Lead Spacing 7.5 mm			Lead Spacing 10.0 mm			
Taping Code		T44, T1H	T45, T1X, T40, T4X	T2, T25	T5, T30	T50, T2X, T35, T2D	T60, T3X
Body Diameter	D	24Max**	24Max**	24Max**	24Max	24Max	24Max
Lead Wire Diameter	d	0.8 ± 0.1	0.8 ± 0.1	0.8 ± 0.1	1.0 ± 0.1	1.0 ± 0.1	1.0 ± 0.1
Pitch of Component	P	25.4 ± 1	25.4 ± 1	25.4 ± 1	25.4 ± 1	25.4 ± 1	25.4 ± 1
Hole Center to Component Center	P ₂	12.7 ± 0.3	12.7 ± 0.3	12.7 ± 0.3	12.7 ± 0.3	12.7 ± 0.3	12.7 ± 0.3
Feed Hole Pitch	P ₀	12.7 ± 0.3	12.7 ± 0.3	12.7 ± 0.3	12.7 ± 0.3	12.7 ± 0.3	12.7 ± 0.3
Lead to Lead Distance (Center to Center)	F	7.5 ± 0.8	7.5 ± 0.8	7.5 ± 0.8	10.0 ± 1.0	10.0 ± 1.0	10.0 ± 1.0
Component Alignment	Δh	2.0Max	2.0Max	2.0Max	2.0Max	2.0Max	2.0Max
Base paper Tape Width	W	18*	18*	18*	18*	18*	18*
Adhesive Tape Width	W ₀	10Min	10Min	10Min	10Min	10Min	10Min
Hole Position	W ₁	9 ± 0.5	9 ± 0.5	9 ± 0.5	9 ± 0.5	9 ± 0.5	9 ± 0.5
Adhesive Tape Border	W ₂	1.5Max	1.5Max	1.5Max	1.5Max	1.5Max	1.5Max
Component Height	H ₁	48Max**	48Max**	48Max**	48Max	48Max	48Max
Lead-Wire Protrusion	L _x	1.0Max	1.0Max	1.0Max	1.0Max	1.0Max	1.0Max
Feed Hole Diameter	D ₀	4 ± 0.2	4 ± 0.2	4 ± 0.2	4 ± 0.2	4 ± 0.2	4 ± 0.2
Total Tape Thickness	t	< 0.7	< 0.7	< 0.7	< 0.7	< 0.7	< 0.7
Length of Clipped Lead	L	11Max	11Max	11Max	11Max	11Max	11Max
Component Height from Seating Plane	A	-	29Max**	28Max**	-	29Max	28Max

Based on EIA-468-B Specification
 All dimensions are in millimeters.
 * Tolerances are +1 and -0.5
 ** For 18Ø, D=22max, H₁=46max and A=26max.

Straight Leads Part Number No Suffix

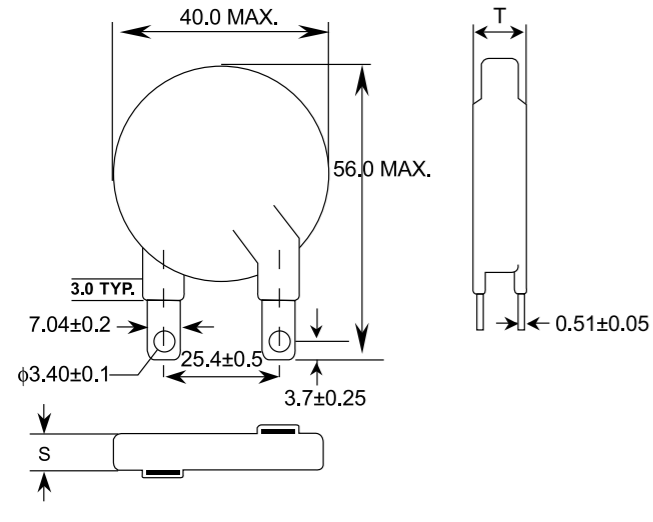

90° Bend Leads Part Number Suffix "Q"

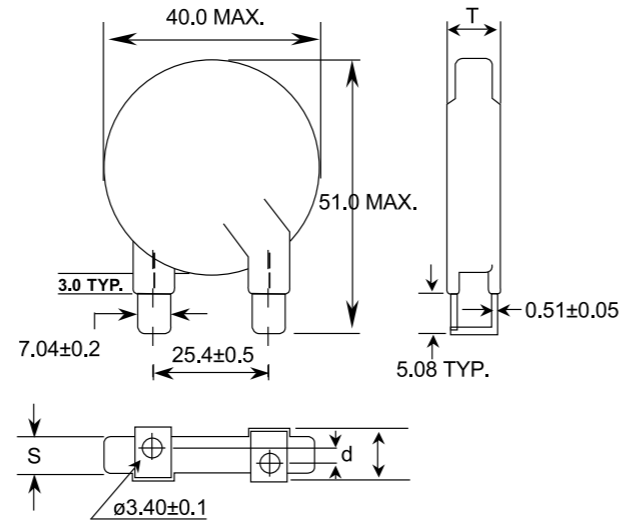

Part Number	Maximum Ratings.				Electrical Characteristics					Tmax.	s	d
	Continuous Rated Voltage		Rated Single Pulse Transient		Varistor Voltage @ 1mA DC		Maximum Clamping Voltage @ Test Current 8/20ms		Typical Capacitance @1KHZ 25°C			
	AC RMS Volts	DC Volts	Energy	Peak	Min Volts	Max Volts	Volts	Amps				
			10/1000µs Jules	8/20µs KAmps								
SR201K32D □	130	175	210	30	184	224	340	200	4700	7.5	2.5±1.0	5.7±1.0
SR221K32D □	140	180	225	30	198	242	360	200	4300	7.5	2.5±1.0	5.5±1.0
SR241K32D □	150	200	240	30	216	264	395	200	4000	7.5	2.8±1.0	5.4±1.0
SR271K32D □	180	230	255	30	255	311	455	200	3500	8.5	2.8±1.0	5.2±1.0
SR331K32D □	210	275	300	30	297	363	550	200	3000	9.0	3.1±1.0	4.8±1.0
SR361K32D □	230	300	315	30	324	396	595	200	2800	9.0	3.3±1.0	4.6±1.0
SR391K32D □	250	330	330	30	351	429	650	200	2500	9.0	3.6±1.0	4.4±1.0
SR431K32D □	275	370	360	30	387	473	710	200	2200	9.0	3.6±1.0	4.2±1.0
SR471K32D □	300	385	380	30	423	517	775	200	2000	9.7	3.8±1.0	4.2±1.0
SR511K32D □	320	420	430	30	459	561	840	200	1900	9.7	3.8±1.0	4.0±1.0
SR621K32D □	390	505	470	30	558	682	1025	200	1600	9.7	4.3±1.0	3.9±1.0
SR681K32D □	420	560	495	30	612	748	1120	200	1500	9.7	4.6±1.0	3.6±1.0
SR751K32D □	460	615	520	30	675	825	1240	200	1400	10.5	4.8±1.0	3.3±1.0
SR781K32D □	485	640	550	30	702	858	1290	200	1300	10.5	4.8±1.0	3.1±1.0
SR821K32D □	510	675	580	30	738	902	1355	200	1200	10.5	5.1±1.0	2.9±1.0
SR911K32D □	550	745	620	30	819	1001	1500	200	1150	11.5	5.6±1.0	2.5±1.0
SR951K32D □	575	765	650	30	855	1043	1570	200	1100	11.5	5.6±1.0	2.3±1.0
SR102K32D □	625	825	680	30	900	1100	1650	200	1000	12.0	5.8±1.0	2.1±1.0
SR112K32D □	680	895	760	30	962	1175	1815	200	900	12.0	6.4±1.0	2.1±1.0

□ - Part Number Suffix Code (ie: SR201K32DML)

No suffix - Straight Lead

Q - 90° Bend Lead

F - Un-coated Disk - with Leads

ML - One Side coated Disk - with one Left Orientation Lead only

NL - Uncoated Disk - with one Left Orientation Lead only

L - Straight Lead - Left Side Lead Orientation

R - Uncoated Disk - without Leads

M - One Side Coated Disk - with one Right Orientation Lead only

N - Uncoated Disk - with one Right Orientation Lead only

UL 1449 recognized (File # E172311)

UL 1414 recognized (File # E182369)

CSA 22.2 #1 certified (File #206608M000)

Approvals not applicable for uncoated disk product

Packing: 340pcs/carton for varistor voltage ≤ 391K, 320pcs/carton for varistor voltage 431K-621K, 260pcs/carton for varistor voltage ≥ 681K.

Packing quantity may subject to change without notice, please contact sales for confirmation.

Straight Leads Part Number No Suffix

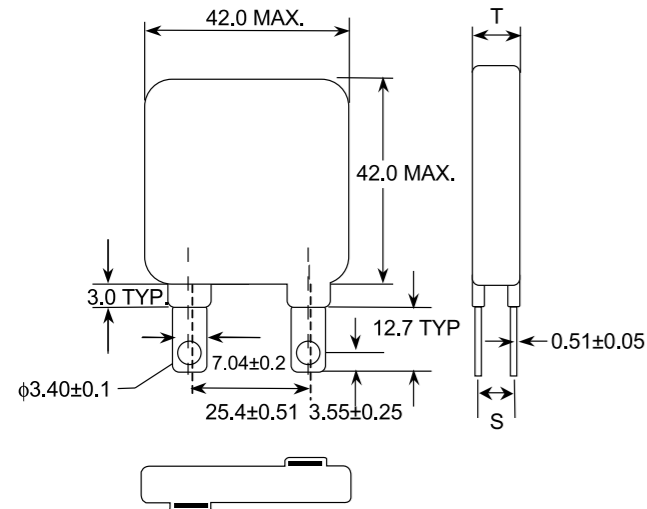

90° Bend Leads Part Number Suffix "Q"

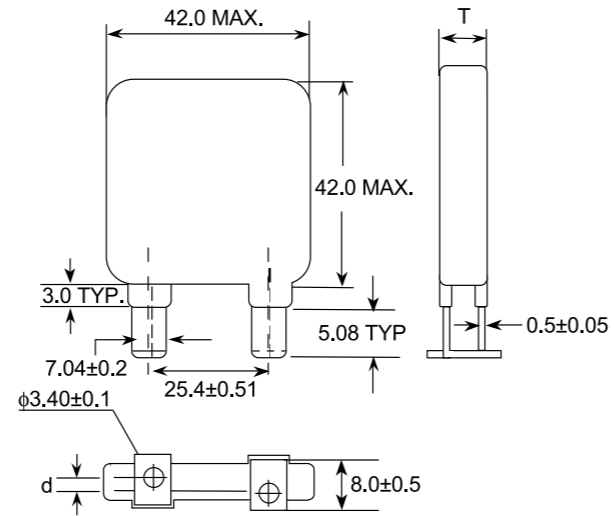

Part Number	Maximum Ratings.				Electrical Characteristics					Tmax.	s	d
	Continuous Rated Voltage		Rated Single Pulse Transient		Varistor Voltage @ 1mA DC		Maximum Clamping Voltage @ Test Current 8/20ms		Typical Capacitance @ 1KHZ 25°C			
	AC RMS Volts	DC Volts	Energy	Peak	Min Volts	Max Volts	Volts	Amps	PF			
			10/1000µs Jules	8/20µs KAmps								
SR201K34R □	130	175	310	40	185	225	340	300	10000	7.5	2.5±1.0	5.7±1.0
SR221K34R □	140	180	330	40	198	242	360	300	9000	7.5	2.5±1.0	5.5±1.0
SR241K34R □	150	200	360	40	216	264	395	300	8000	7.5	2.8±1.0	5.4±1.0
SR271K34R □	180	230	390	40	255	311	455	300	7100	8.5	2.8±1.0	5.2±1.0
SR301K34R □	195	250	405	40	270	330	505	300	6500	9.0	3.0±1.0	5.0±1.0
SR331K34R □	210	275	430	40	297	363	550	300	6000	9.0	3.1±1.0	4.8±1.0
SR361K34R □	230	300	460	40	324	396	595	300	5600	9.0	3.3±1.0	4.6±1.0
SR391K34R □	250	330	490	40	351	429	650	300	5000	9.0	3.6±1.0	4.4±1.0
SR431K34R □	275	370	550	40	387	473	710	300	4500	9.0	3.6±1.0	4.2±1.0
SR471K34R □	300	385	600	40	423	517	775	300	4000	9.7	3.8±1.0	4.2±1.0
SR511K34R □	320	420	640	40	459	561	840	300	3800	9.7	3.8±1.0	4.0±1.0
SR561K34R □	360	470	710	40	522	638	910	300	3500	9.7	4.0±1.0	4.0±1.0
SR621K34R □	390	505	800	40	558	682	1025	300	3200	9.7	4.3±1.0	3.9±1.0
SR681K34R □	420	560	910	40	612	748	1120	300	2900	9.7	4.6±1.0	3.6±1.0
SR751K34R □	460	615	980	40	675	825	1240	300	2700	10.5	4.8±1.0	3.3±1.0
SR781K34R □	485	640	1020	40	702	858	1290	300	2500	10.5	5.1±1.0	3.1±1.0
SR821K34R □	510	675	1100	40	738	902	1355	300	2300	10.5	5.6±1.0	2.9±1.0
SR911K34R □	550	745	1150	40	819	1001	1500	300	2100	11.5	5.6±1.0	2.5±1.0
SR951K34R □	575	765	1200	40	855	1043	1570	300	1900	11.5	5.6±1.0	2.3±1.0
SR102K34R □	625	825	1250	40	900	1100	1650	300	1700	12.0	5.8±1.0	2.1±1.0
SR112K34R □	680	895	1350	40	962	1175	1815	300	1500	12.0	6.4±1.0	2.1±1.0

□ - Part Number Suffix Code (i.e.: SR201K34RML)

No suffix - Straight Lead

Q - 90° Bend Lead

F - Un-coated Disk - with Leads

ML - One Side coated Disk - with one Left Orientation Lead only

NL - Uncoated Disk - with one Left Orientation Lead only

L - Straight Lead - Left Side Lead Orientation

R - Uncoated Disk - without Leads

M - One Side Coated Disk - with one Right Orientation Lead only

N - Uncoated Disk - with one Right Orientation Lead only

UL 1449 recognized (File # 172311)

UL 1414 pending

CSA 22.2 #1 recognized (File # 206608)

Approvals not applicable for uncoated disk product

Packing: 340pcs/carton for varistor voltage ≤ 391K, 320pcs/carton for varistor voltage 431K-621K, 260pcs/carton for varistor voltage ≥ 681K.

Packing quantity may subject to change without notice, please contact sales for confirmation.

Straight Leads Part Number No Suffix

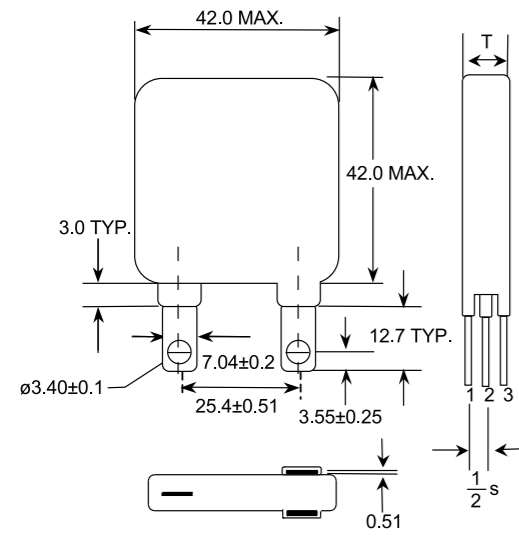

90° Bend Leads Part Number Suffix "Q"

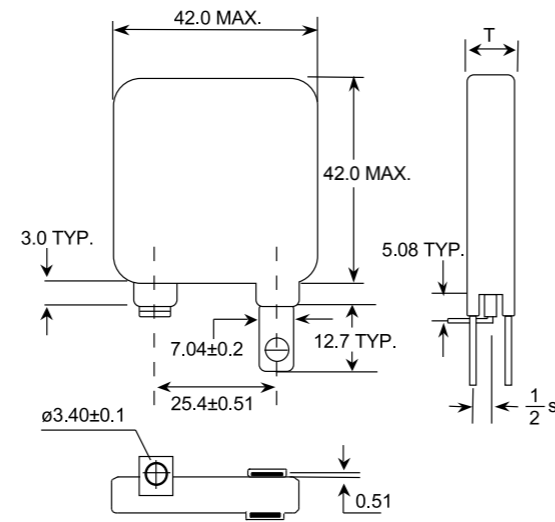

Part Number	Maximum Ratings.					Electrical Characteristics						Tmax.	s
	Continuous Rated Voltage		Rated Single Pulse Transient			Varistor Voltage @ 1mA DC		Maximum Clamping Voltage @ Test Current 8/20ms		Typical Capacitance @ 1KHZ 25°C			
	AC RMS Volts	DC Volts	Energy	Peak		Min Volts	Max Volts	Volts	Amps	PF			
			10/1000µs Jules	8/20µs KAmps Lead 1-2 or 2-3	8/20µs KAmps Lead 1-3								
SR201K34RD □	130	175	310	40	80	185	225	340	300	7900	9.1	4.1±1.0	
SR221K34RD □	140	180	330	40	80	198	242	360	300	7200	9.2	4.2±1.0	
SR241K34RD □	150	200	360	40	80	216	264	395	300	6600	9.3	4.6±1.0	
SR271K34RD □	180	230	390	40	80	255	311	455	300	5600	9.5	4.8±1.0	
SR301K34RD □	195	250	405	40	80	270	330	505	300	5200	10.5	5.2±1.0	
SR331K34RD □	210	275	430	40	80	297	363	550	300	4800	11.3	5.4±1.0	
SR361K34RD □	230	300	460	40	80	324	396	595	300	4400	11.5	5.8±1.0	
SR391K34RD □	250	330	490	40	80	351	429	650	300	4100	11.6	6.2±1.0	
SR431K34RD □	275	370	550	40	80	387	473	710	300	3800	11.9	6.5±1.0	
SR471K34RD □	300	385	600	40	80	423	517	775	300	3400	12.8	6.9±1.0	
SR511K34RD □	320	420	640	40	80	459	561	840	300	3200	13.1	7.2±1.0	
SR561K34RD □	360	470	710	40	80	522	638	910	300	2700	13.4	7.7±1.0	
SR621K34RD □	390	505	800	40	80	558	682	1025	300	2600	13.6	8.2±1.0	
SR681K34RD □	420	560	910	40	80	612	748	1120	300	2400	13.9	8.8±1.0	
SR751K34RD □	460	615	980	40	80	675	825	1240	300	2200	15.3	9.3±1.0	
SR781K34RD □	485	640	1020	40	80	702	858	1290	300	2100	15.5	9.6±1.0	
SR821K34RD □	510	675	1100	40	80	738	902	1355	300	2000	15.5	10.1±1.0	
SR911K34RD □	550	745	1150	40	80	819	1001	1500	300	1800	17.0	11.1±1.0	
SR951K34RD □	575	765	1200	40	80	855	1045	1570	300	1700	17.2	11.3±1.0	
SR102K34RD □	625	825	1250	40	80	900	1100	1650	300	1600	18.0	11.8±1.0	
SR112K34RD □	680	895	1350	40	80	962	1175	1815	300	1500	18.6	13.0±1.0	

□ - Part Number Suffix Code (ie: SR201K34RD)

No suffix - Straight Lead

Q - 90° Bend Lead

UL 1449 recognized (File # 172311)

UL 1414 pending

CSA 22.2 #1 recognized (File # 206608)

Approvals not applicable for uncoated disk product

Packing: 340pcs/carton for varistor voltage ≤ 391K, 320pcs/carton for varistor voltage 431K-621K, 260pcs/carton for varistor voltage ≥ 681K.

Packing quantity may subject to change without notice, please contact sales for confirmation.

Straight Leads Part Number No Suffix

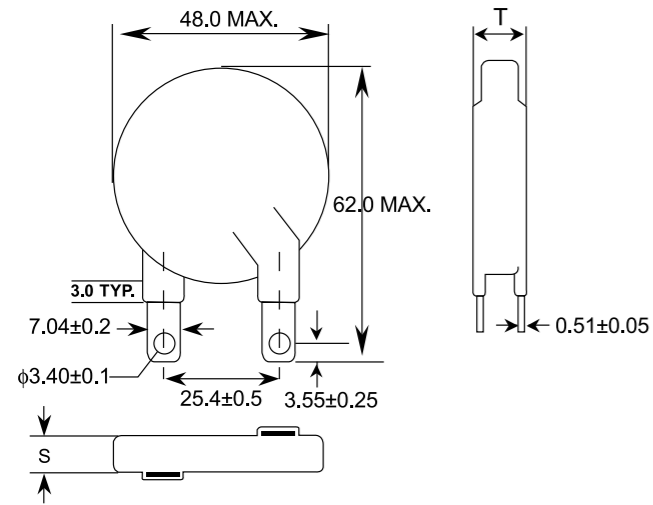

90° Bend Leads Part Number Suffix "Q"

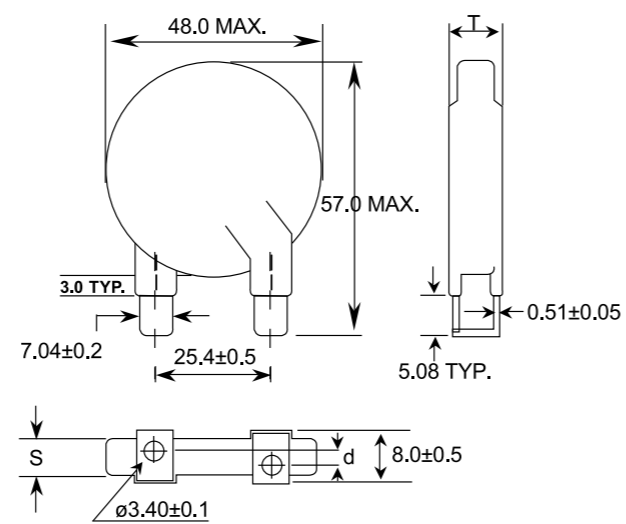

Part Number	Maximum Ratings.				Electrical Characteristics					Tmax.	s	d
	Continuous Rated Voltage		Rated Single Pulse Transient		Varistor Voltage @ 1mA DC		Maximum Clamping Voltage @ Test Current 8/20ms		Typical Capacitance @ 1KHZ 25°C			
	AC RMS Volts	DC Volts	Energy	Peak	Min Volts	Max Volts	Volts	Amps	PF			
			10/1000µs Jules	8/20µs KAmps								
SR201K40D □	130	175	310	40	185	225	340	300	10000	7.5	2.5±1.0	5.7±1.0
SR221K40D □	140	180	330	40	198	242	360	300	9000	7.5	2.5±1.0	5.5±1.0
SR241K40D □	150	200	360	40	216	264	395	300	8000	7.5	2.8±1.0	5.4±1.0
SR271K40D □	180	230	390	40	255	311	455	300	7100	8.5	2.8±1.0	5.2±1.0
SR331K40D □	210	275	460	40	297	363	550	300	6000	9.0	3.1±1.0	4.8±1.0
SR361K40D □	230	300	475	40	324	396	595	300	5600	9.0	3.3±1.0	4.6±1.0
SR391K40D □	250	330	490	40	351	429	650	300	5000	9.0	3.6±1.0	4.4±1.0
SR431K40D □	275	370	550	40	387	473	710	300	4500	9.0	3.6±1.0	4.2±1.0
SR471K40D □	300	385	600	40	423	517	775	300	4000	9.7	3.8±1.0	4.2±1.0
SR511K40D □	320	420	640	40	459	561	840	300	3800	9.7	3.8±1.0	4.0±1.0
SR621K40D □	390	505	800	40	558	682	1025	300	3300	9.7	4.3±1.0	3.9±1.0
SR681K40D □	420	560	910	40	612	748	1120	300	3000	9.7	4.6±1.0	3.6±1.0
SR751K40D □	460	615	920	40	675	825	1240	300	2600	10.5	4.8±1.0	3.3±1.0
SR781K40D □	485	640	930	40	702	858	1290	300	2500	10.5	4.8±1.0	3.1±1.0
SR821K40D □	510	675	940	40	738	902	1355	300	2300	10.5	5.1±1.0	2.9±1.0
SR911K40D □	550	745	960	40	819	1001	1500	300	2200	11.5	5.6±1.0	2.5±1.0
SR951K40D □	575	765	1000	40	855	1043	1570	300	2000	11.5	5.6±1.0	2.3±1.0
SR102K40D □	625	825	1055	40	900	1100	1650	300	1900	12.0	5.8±1.0	2.1±1.0
SR112K40D □	680	895	1155	40	962	1175	1815	300	1800	12.0	6.4±1.0	2.1±1.0

□- Part Number Suffix Code (ie: SR201K40DQ)

No suffix - Straight Lead

Q - 90° Bend Lead

F - Un-coated Disk - with Leads

ML - One Side coated Disk - with one Left Orientation Lead only

NL - Uncoated Disk - with one Left Orientation Lead only

UL 1449 recognized (File # E172311)

UL 1414 recognized (File # E182369)

CSA 22.2 #1 certified (File #206608M000)

Approvals not applicable for uncoated disk product

Packing: 340pcs/carton for varistor voltage ≤ 391K, 320pcs/carton for varistor voltage 431K-621K, 260pcs/carton for varistor voltage ≥ 681K.

Packing quantity may subject to change without notice, please contact sales for confirmation.

L - Straight Lead - Left Side Lead Orientation

R - Uncoated Disk - without Leads

M - One Side Coated Disk - with one Right Orientation Lead only

N - Uncoated Disk - with one Right Orientation Lead only

Straight Leads Part Number No Suffix

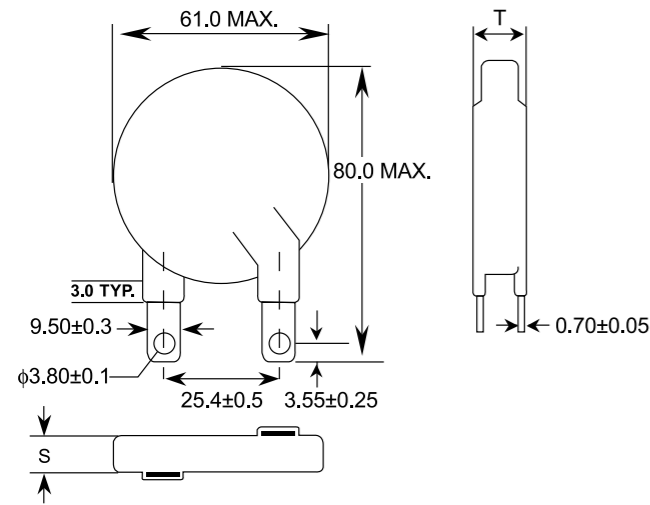

90° Bend Leads Part Number Suffix "Q"

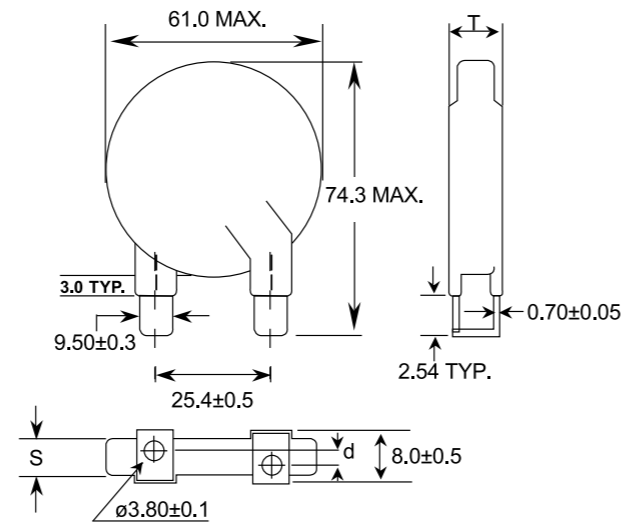

Part Number	Maximum Ratings.				Electrical Characteristics					Tmax.	s	d
	Continuous Rated Voltage		Rated Single Pulse Transient		Varistor Voltage @ 1mA DC		Maximum Clamping Voltage @ Test Current 8/20ms		Typical Capacitance @ 1KHZ 25°C			
	AC RMS Volts	DC Volts	Energy	Peak	Min Volts	Max Volts	Volts	Amps	PF			
			10/1000µs Jules	8/20µs KAmps								
SR201K53D □	130	175	490	70	185	225	340	500	15000	7.5	2.5±1.0	5.7±1.0
SR221K53D □	140	180	530	70	198	242	360	500	13800	7.5	2.5±1.0	5.5±1.0
SR241K53D □	150	200	570	70	216	264	395	500	12500	7.5	2.8±1.0	5.4±1.0
SR271K53D □	180	230	630	70	255	311	455	500	11000	8.5	2.8±1.0	5.2±1.0
SR331K53D □	210	275	680	70	297	363	550	500	9000	9.0	3.1±1.0	4.8±1.0
SR361K53D □	230	300	730	70	324	396	595	500	8500	9.0	3.3±1.0	4.6±1.0
SR391K53D □	250	330	880	70	351	429	650	500	7500	9.0	3.6±1.0	4.4±1.0
SR431K53D □	275	370	950	70	387	473	710	500	7000	9.0	3.6±1.0	4.2±1.0
SR471K53D □	300	385	1000	70	423	517	775	500	6500	9.7	3.8±1.0	4.2±1.0
SR511K53D □	320	420	1100	70	459	561	840	500	6000	9.7	3.8±1.0	4.0±1.0
SR561K53D □	360	470	1200	70	522	638	910	500	5600	9.7	4.3±1.0	4.0±1.0
SR621K53D □	390	505	1300	70	558	682	1025	500	5200	9.7	4.3±1.0	3.9±1.0
SR681K53D □	420	560	1500	70	612	748	1120	500	4800	9.7	4.6±1.0	3.6±1.0
SR751K53D □	460	615	1600	70	675	825	1240	500	4300	10.5	4.6±1.0	3.3±1.0
SR781K53D □	485	640	1650	70	702	858	1290	500	3900	10.5	4.8±1.0	3.1±1.0
SR821K53D □	510	675	1800	70	738	902	1355	500	3700	10.5	5.1±1.0	2.9±1.0
SR911K53D □	550	745	2000	70	819	1001	1500	500	3300	11.5	5.6±1.0	2.5±1.0
SR951K53D □	575	765	2100	70	855	1043	1570	500	3200	11.5	5.6±1.0	2.3±1.0
SR102K53D □	625	825	2200	70	900	1100	1650	500	3000	11.5	5.8±1.0	2.1±1.0
SR112K53D □	680	895	2500	70	962	1175	1815	500	2800	11.5	6.4±1.0	2.1±1.0
SR122K53D □	750	970	2700	70	1062	1300	1980	500	2700	12.6	7.0±1.0	1.5±1.0

□ - Part Number Suffix Code (ie: SR201K53DQ)

No suffix - Straight Lead

Q - 90° Bend Lead

F - Un-coated Disk - with Leads

ML - One Side coated Disk - with one Left Orientation Lead only

NL - Uncoated Disk - with one Left Orientation Lead only

L - Straight Lead - Left Side Lead Orientation

R - Uncoated Disk - without Leads

M - One Side Coated Disk - with one Right Orientation Lead only

N - Uncoated Disk - with one Right Orientation Lead only

UL 1449 recognized (File # 172311)

UL 1414 pending

CSA 22.2 #1 recognized (File # 206608)

Approvals not applicable for uncoated disk product

Packing: 170pcs/carton for varistor voltage ≤ 391K, 160pcs/carton for varistor voltage 431K-621K, 130pcs/carton for varistor voltage ≥ 681K.

Packing quantity may subject to change without notice, please contact sales for confirmation.

V-I Curve for SR201K~431K32D Series

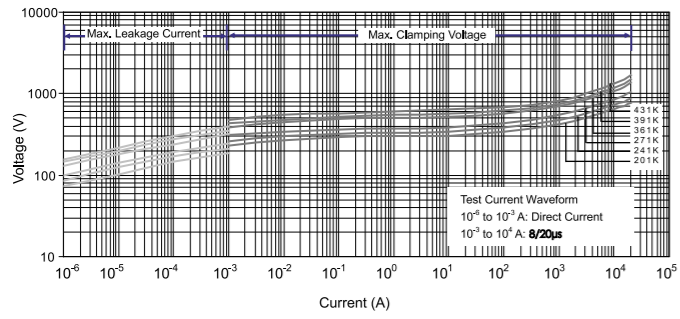

V-I Curve for SR471K~951K32D Series

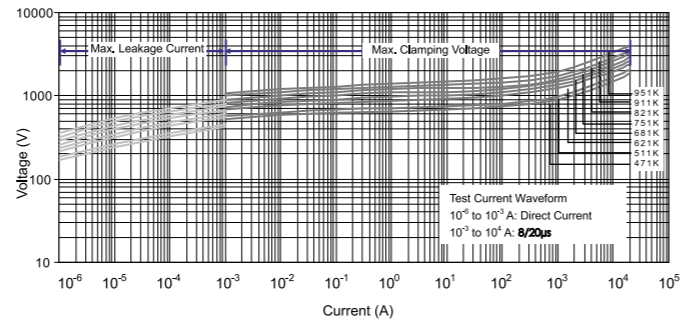

V-I Curve for SR201K~431K34R Series

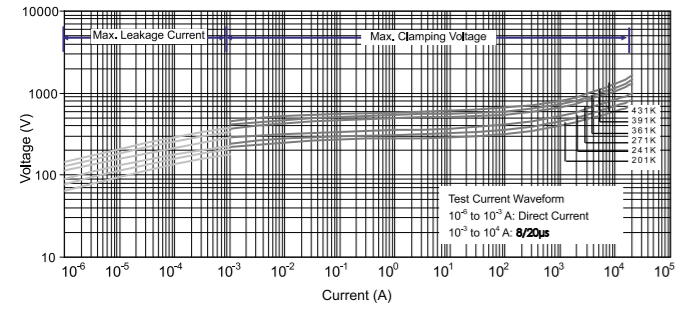

V-I Curve for SR471K~951K34R Series

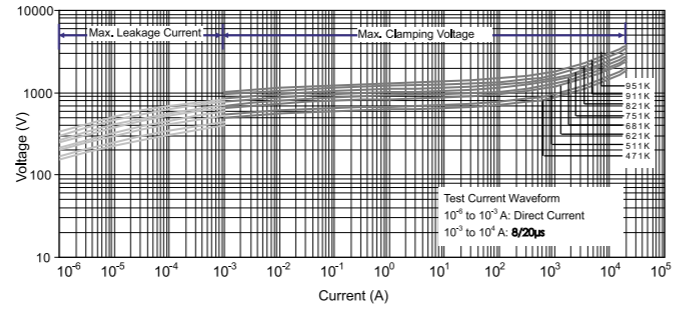

V-I Curve for SR201K~431K40D Series

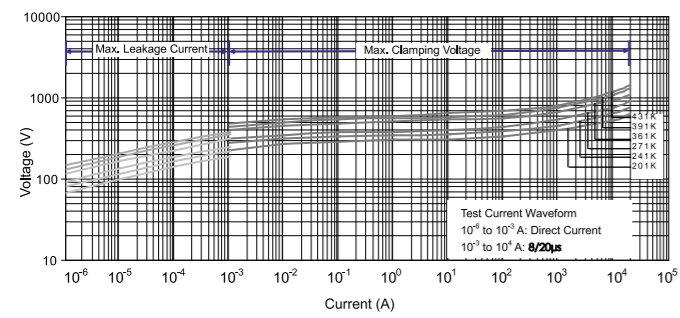

V-I Curve for SR471K~951K40D Series

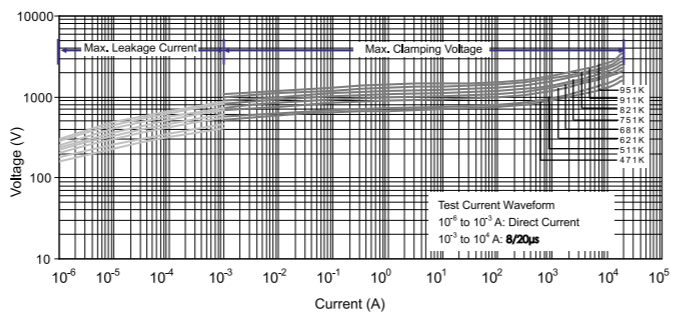

V-I Curve for SR201K~431K53D Series

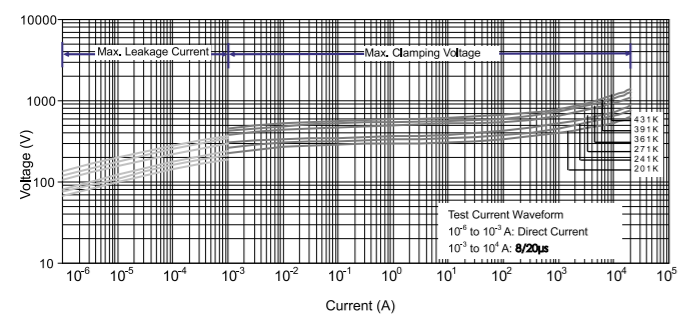

V-I Curve for SR471K~951K53D Series

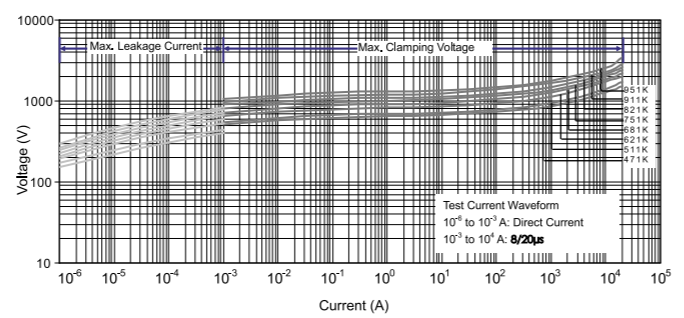

■ Wave Soldering Profile

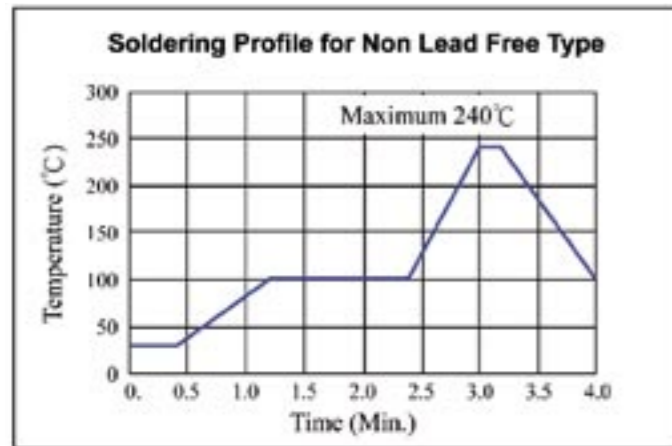



MOV Varistors

2008



WALSIN[®] 華新科技
Walsin Technology Corporation

Yang-Mei

Walsin Technology Corporation
566-1, Kao-Shi Road, Yang-Mei,
Tao-Yuan, Taiwan
Tel: 886-3-475-8711
Fax: 886-3-475-7129 475-7130
E-mail: info@passivecomponent.com

Kaohsiung

Walsin Technology Corporation
1st, West 13 Street, K.E.P.Z.
Kaohsiung, Taiwan
Tel: 886-7-821-8171
Fax: 886-7-813-1661
E-mail: info@passivecomponent.com

Feb. 2008