

## High Speed Infrared Emitting Diodes, 940 nm, Surface Emitter Technology

VSMY2941RGX01



VSMY2941GX01



### DESCRIPTION

As part of the [SurfLight™](#) portfolio, the VSMY2941X01 series are infrared, 940 nm emitting diodes based on GaAlAs surface emitter chip technology with extreme high radiant intensities, high optical power and high speed, molded in clear, untinted plastic packages (with lens) for surface mounting (SMD).

### APPLICATIONS

- Miniature light barrier
- Photointerrupters
- Optical switch
- Emitter source for proximity sensors

### FEATURES

- Package type: surface-mount
- Package form: GW, RGW
- Dimensions (L x W x H in mm): 2.3 x 2.3 x 2.8
- Peak wavelength:  $\lambda_p = 940$  nm
- AEC-Q101 qualified
- High radiant power
- Very high radiant intensity
- Angle of half intensity:  $\phi = \pm 8^\circ$
- Terminal configurations: gullwing or reverse gullwing
- Package matches with detector VEMD2000X01 series
- Floor life: 4 weeks, MSL 2a, according to J-STD-020
- Material categorization: for definitions of compliance please see [www.vishay.com/doc?99912](http://www.vishay.com/doc?99912)

 AUTOMOTIVE  
GRADE

**RoHS**  
COMPLIANT  
HALOGEN  
**FREE**  
**GREEN**  
(5-2008)

PRODUCT SUMMARY				
COMPONENT	$I_e$ (mW/sr)	$\phi$ (deg)	$\lambda_p$ (nm)	$t_r$ (ns)
VSMY2941RGX01	160	$\pm 8$	940	5
VSMY2941GX01	160	$\pm 8$	940	5

#### Note

- Test conditions see table "Basic Characteristics"

ORDERING INFORMATION			
ORDERING CODE	PACKAGING	REMARKS	PACKAGE FORM
VSMY2941RGX01	Tape and reel	MOQ: 6000 pcs, 6000 pcs/reel	Reverse gullwing
VSMY2941GX01	Tape and reel	MOQ: 6000 pcs, 6000 pcs/reel	Gullwing

#### Note

- MOQ: minimum order quantity

ABSOLUTE MAXIMUM RATINGS ( $T_{amb} = 25$ °C, unless otherwise specified)				
PARAMETER	TEST CONDITION	SYMBOL	VALUE	UNIT
Reverse voltage		$V_R$	5	V
Forward current		$I_F$	70	mA
Peak forward current	$t_p/T = 0.5, t_p = 100$ $\mu$ s	$I_{FM}$	140	mA
Surge forward current	$t_p = 100$ $\mu$ s	$I_{FSM}$	500	mA
Power dissipation		$P_V$	120	mW
Junction temperature		$T_j$	100	°C
Operating temperature range		$T_{amb}$	-40 to +85	°C
Storage temperature range		$T_{stg}$	-40 to +100	°C
Soldering temperature	According to Fig. 10, J-STD-020	$T_{sd}$	260	°C
Thermal resistance junction-to-ambient	J-STD-051, soldered on PCB	$R_{thJA}$	250	K/W

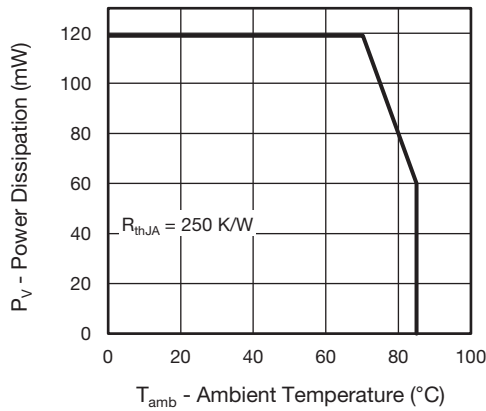


Fig. 1 - Power Dissipation Limit vs. Ambient Temperature

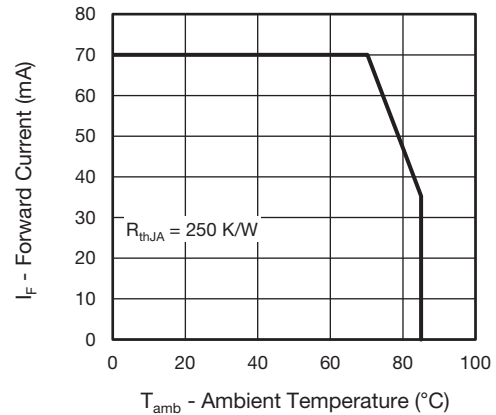


Fig. 2 - Forward Current Limit vs. Ambient Temperature

BASIC CHARACTERISTICS (T <sub>amb</sub> = 25 °C, unless otherwise specified)						
PARAMETER	TEST CONDITION	SYMBOL	MIN.	TYP.	MAX.	UNIT
Forward voltage	I <sub>F</sub> = 50 mA, t <sub>p</sub> = 20 ms	V <sub>F</sub>	-	1.4	1.7	V
	I <sub>F</sub> = 70 mA, t <sub>p</sub> = 20 ms	V <sub>F</sub>	-	1.5	-	V
	I <sub>F</sub> = 500 mA, t <sub>p</sub> = 100 μs	V <sub>F</sub>	-	2.6	-	V
Temperature coefficient of V <sub>F</sub>	I <sub>F</sub> = 50 mA	TK <sub>V<sub>F</sub></sub>	-	-0.7	-	mV/K
Reverse current		I <sub>R</sub>	Not designed for reverse operation			μA
Junction capacitance	V <sub>R</sub> = 0 V, f = 1 MHz, E = 0 mW/cm <sup>2</sup>	C <sub>J</sub>	-	30	-	pF
Radiant intensity	I <sub>F</sub> = 50 mA, t <sub>p</sub> = 20 ms	I <sub>e</sub>	60	115	170	mW/sr
	I <sub>F</sub> = 70 mA, t <sub>p</sub> = 20 ms	I <sub>e</sub>	-	160	-	mW/sr
	I <sub>F</sub> = 500 mA, t <sub>p</sub> = 100 μs	I <sub>e</sub>	-	850	-	mW/sr
Radiant power	I <sub>F</sub> = 70 mA, t <sub>p</sub> = 20 ms	φ <sub>e</sub>	-	40	-	mW
Temperature coefficient of radiant power	I <sub>F</sub> = 50 mA	TKφ <sub>e</sub>	-	-0.2	-	%/K
Angle of half intensity		φ	-	± 8	-	deg
Peak wavelength	I <sub>F</sub> = 50 mA	λ <sub>p</sub>	920	940	960	nm
Spectral bandwidth	I <sub>F</sub> = 70 mA	Δλ	-	55	-	nm
Temperature coefficient of λ <sub>p</sub>	I <sub>F</sub> = 70 mA	TKλ <sub>p</sub>	-	0.28	-	nm/K
Rise time	I <sub>F</sub> = 70 mA, 10 % to 90 %	t <sub>r</sub>	-	5	-	ns
Fall time	I <sub>F</sub> = 70 mA, 10 % to 90 %	t <sub>f</sub>	-	6	-	ns

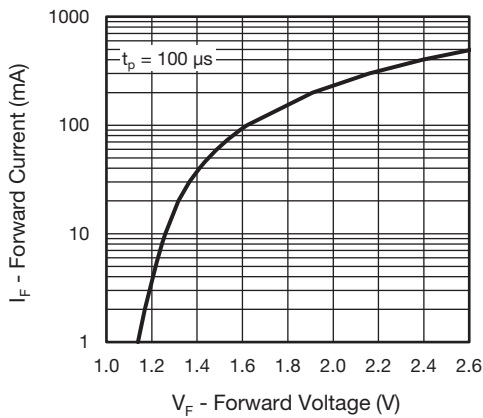
**BASIC CHARACTERISTICS** ( $T_{amb} = 25\text{ }^{\circ}\text{C}$ , unless otherwise specified)


Fig. 3 - Forward Current vs. Forward Voltage

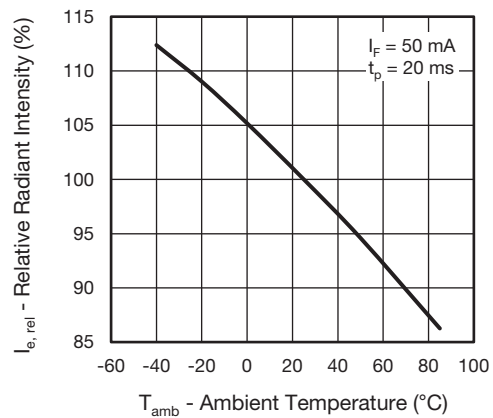


Fig. 6 - Relative Radiant Intensity vs. Ambient Temperature

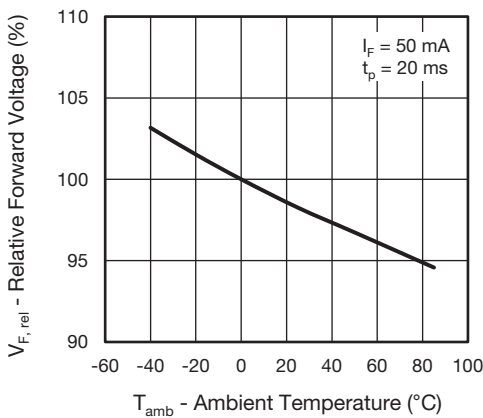


Fig. 4 - Relative Forward Voltage vs. Ambient Temperature

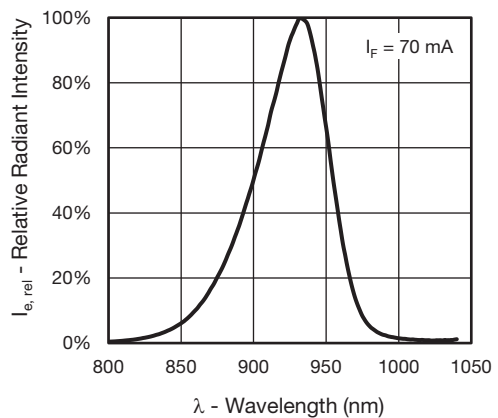


Fig. 7 - Relative Radiant Intensity vs. Wavelength

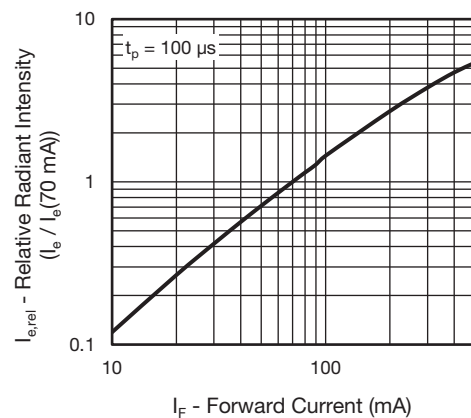


Fig. 5 - Radiant Intensity vs. Forward Current

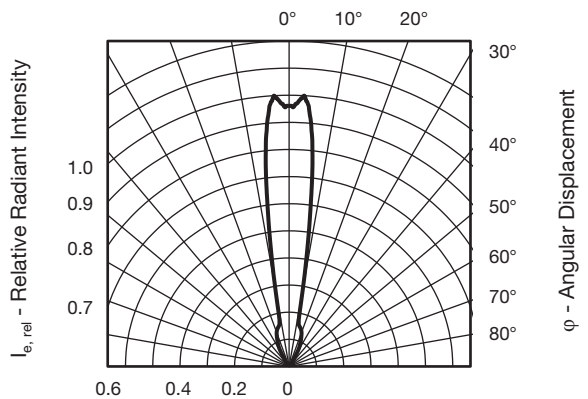
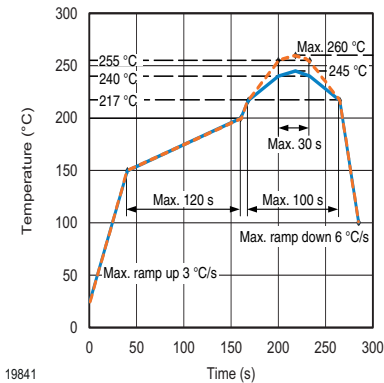


Fig. 8 - Relative Radiant Intensity vs. Angular Displacement



## SOLDER PROFILE



19841

Fig. 9 - Lead (Pb)-free Reflow Solder Profile According to J-STD-020

## DRYPACK

Devices are packed in moisture barrier bags (MBB) to prevent the products from moisture absorption during transportation and storage. Each bag contains a desiccant.

## FLOOR LIFE

Floor life (time between soldering and removing from MBB) must not exceed the time indicated on MBB label:

Floor life: 4 weeks

Conditions:  $T_{amb} < 30\text{ }^{\circ}\text{C}$ ,  $\text{RH} < 60\%$

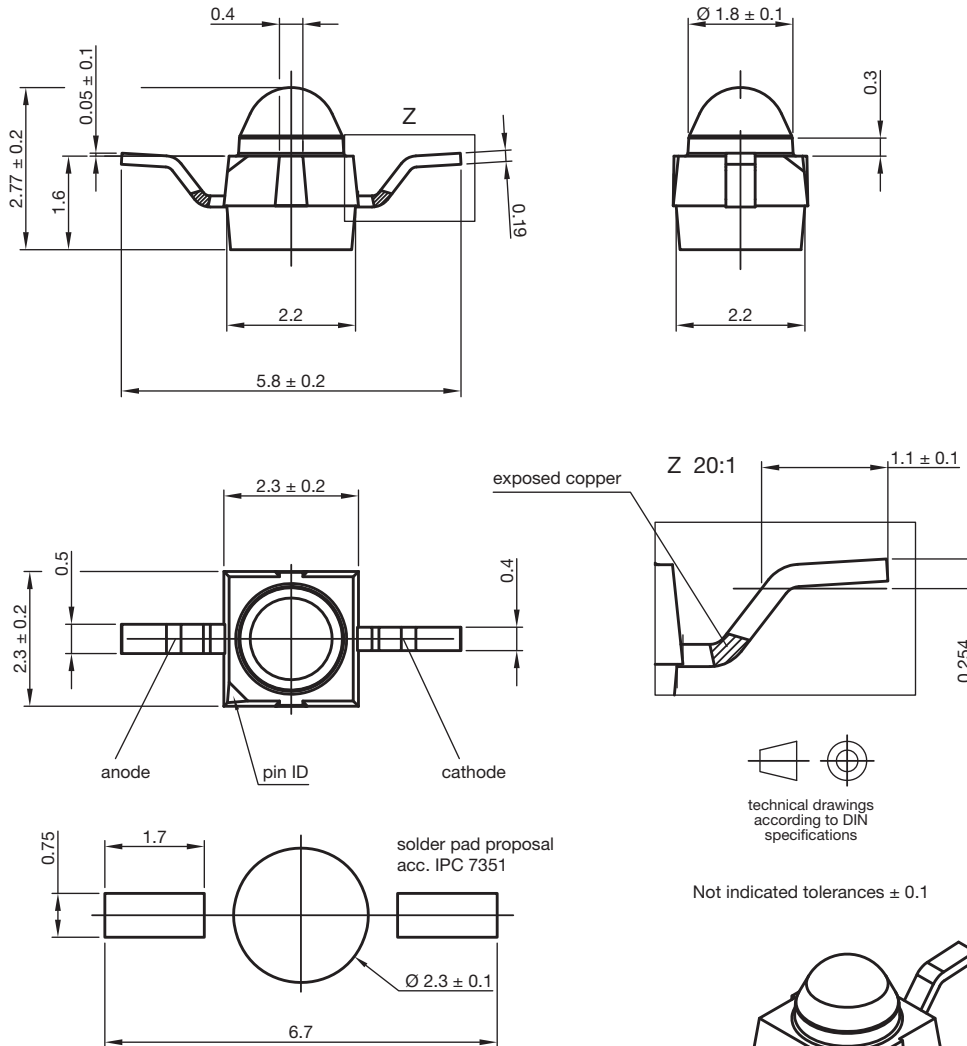
Moisture sensitivity level 2a, according to J-STD-020.

## DRYING

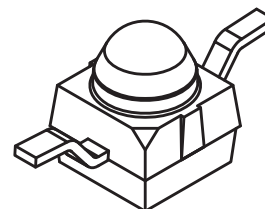
In case of moisture absorption devices should be baked before soldering. Conditions see J-STD-020 or label.

Devices taped on reel dry using recommended conditions 192 h at  $40\text{ }^{\circ}\text{C}$  ( $+ 5\text{ }^{\circ}\text{C}$ ),  $\text{RH} < 5\%$ .

## PACKAGE DIMENSIONS in millimeters: VSMY2941RGX01

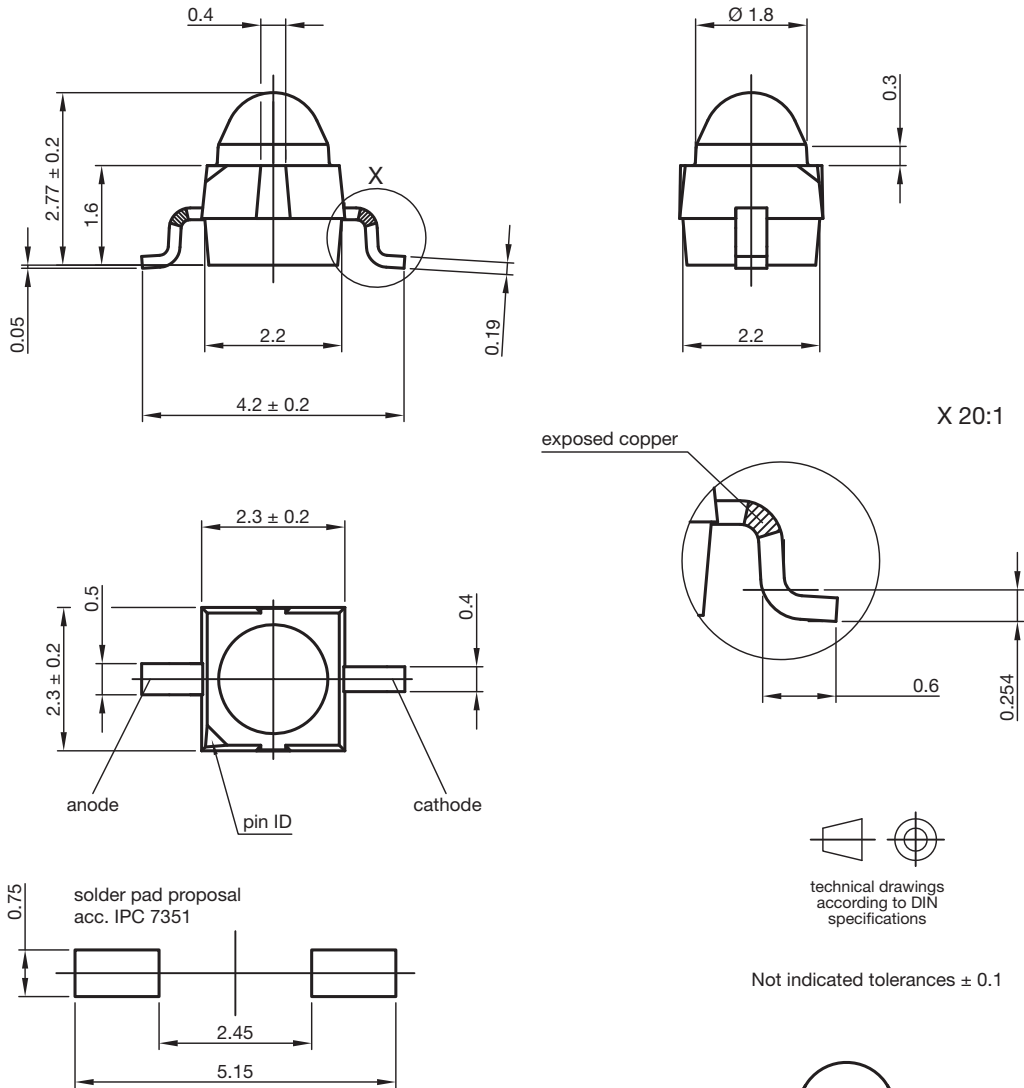


Drawing-No.: 6.544-5391.03-4  
Issue: 2; 19.09.14

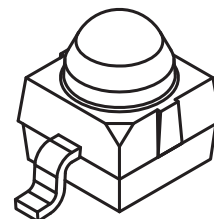




## PACKAGE DIMENSIONS in millimeters: VSMY2941GX01

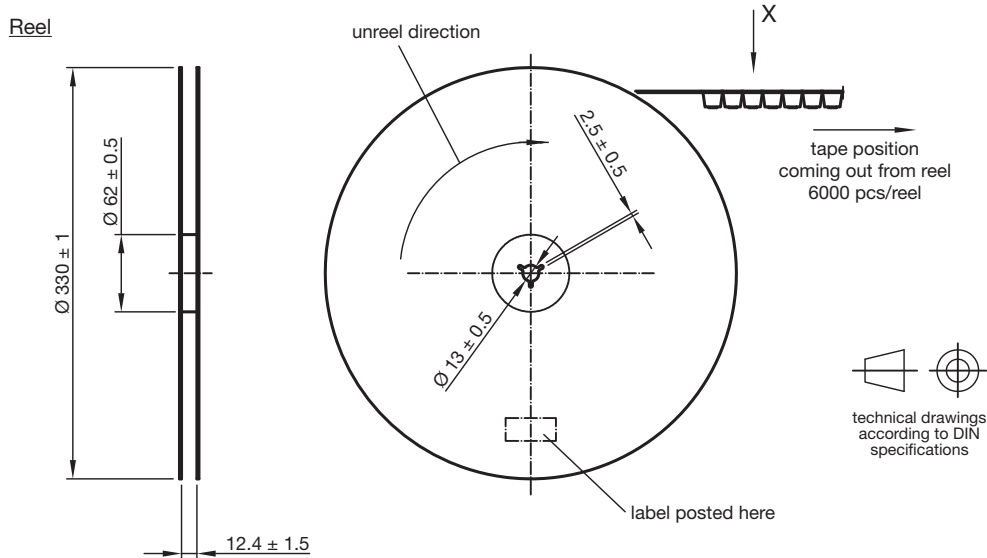


Drawing-No.: 6.544-5383.03-4  
Issue: 2; 19.09.14

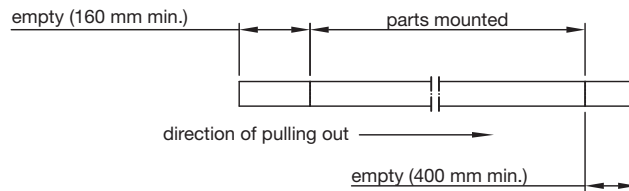




## TAPING AND REEL DIMENSIONS in millimeters: VSMY2941RGX01

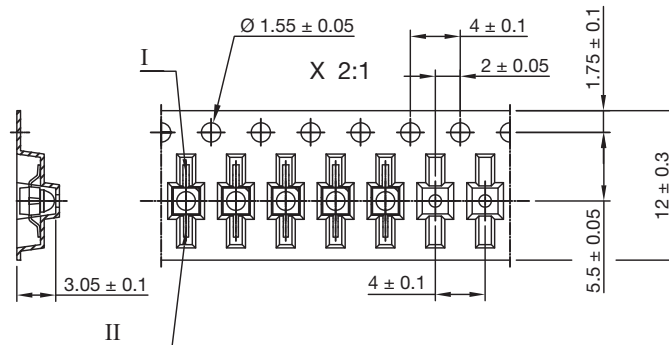


### Leader and trailer tape



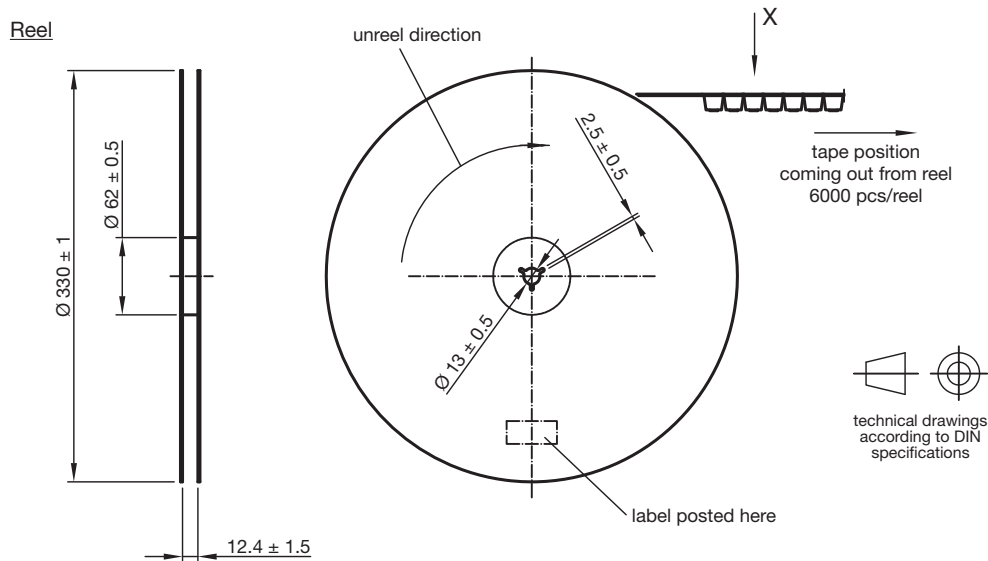
### Terminal position in tape

Device	Lead I	Lead II
VENT2000	Collector	Emitter
VENT2500		
VEMD2000		
VEMD2500	Cathode	Anode
VSMB2000		
VSMG2000		
VSMF2890RG	Anode	Cathode
VSMY2850RG		
VSMY2940RG		

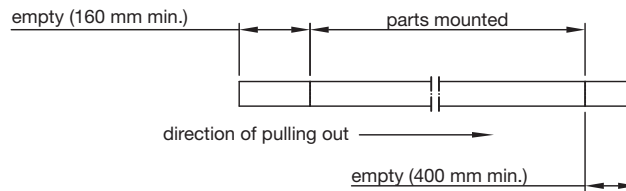


Drawing-No.: 9.800-5100.01-4  
Issue: 4; 19.09.14

## TAPING AND REEL DIMENSIONS in millimeters: VSMY2941GX01

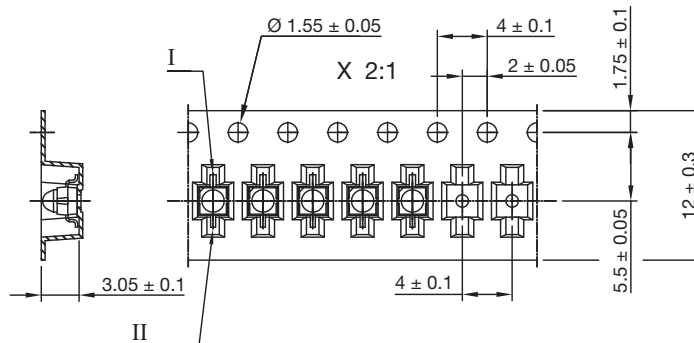


### Leader and trailer tape



### Terminal position in tape

Device	Lead I	Lead II
VSMB2020	Cathode	Anode
VSMG2020		
VEMD2020		
VEMD2520		
VSMF2890G	Collector	Emitter
VEMT2020		
VEMT2520		
VSMY2850G	Anode	Cathode
VSMY2940G		



Drawing-No.: 9.800-5091.01-4  
Issue: 5; 19.09.14



## **Disclaimer**

ALL PRODUCT, PRODUCT SPECIFICATIONS AND DATA ARE SUBJECT TO CHANGE WITHOUT NOTICE TO IMPROVE RELIABILITY, FUNCTION OR DESIGN OR OTHERWISE.

Vishay Intertechnology, Inc., its affiliates, agents, and employees, and all persons acting on its or their behalf (collectively, "Vishay"), disclaim any and all liability for any errors, inaccuracies or incompleteness contained in any datasheet or in any other disclosure relating to any product.

Vishay makes no warranty, representation or guarantee regarding the suitability of the products for any particular purpose or the continuing production of any product. To the maximum extent permitted by applicable law, Vishay disclaims (i) any and all liability arising out of the application or use of any product, (ii) any and all liability, including without limitation special, consequential or incidental damages, and (iii) any and all implied warranties, including warranties of fitness for particular purpose, non-infringement and merchantability.

Statements regarding the suitability of products for certain types of applications are based on Vishay's knowledge of typical requirements that are often placed on Vishay products in generic applications. Such statements are not binding statements about the suitability of products for a particular application. It is the customer's responsibility to validate that a particular product with the properties described in the product specification is suitable for use in a particular application. Parameters provided in datasheets and / or specifications may vary in different applications and performance may vary over time. All operating parameters, including typical parameters, must be validated for each customer application by the customer's technical experts. Product specifications do not expand or otherwise modify Vishay's terms and conditions of purchase, including but not limited to the warranty expressed therein.

Except as expressly indicated in writing, Vishay products are not designed for use in medical, life-saving, or life-sustaining applications or for any other application in which the failure of the Vishay product could result in personal injury or death. Customers using or selling Vishay products not expressly indicated for use in such applications do so at their own risk. Please contact authorized Vishay personnel to obtain written terms and conditions regarding products designed for such applications.

No license, express or implied, by estoppel or otherwise, to any intellectual property rights is granted by this document or by any conduct of Vishay. Product names and markings noted herein may be trademarks of their respective owners.