

WiFi / Bluetooth Chip Antenna  
Model: CW325

Product Number: H2U36D1K1B0300

REFERENCE SPECIFICATION

## Table of Contents

1	Introduction.....	3
2	Electrical Characteristics .....	4
2.1	Table with electrical properties: .....	4
2.2	Return Loss ( $S_{11}$ ) .....	5
2.3	VSWR ( $S_{11}$ ) .....	5
2.4	Efficiency Table.....	6
2.5	Efficiency vs. Frequency.....	6
2.6	Radiation Pattern (with 40x40mm <sup>2</sup> Evaluation Board).....	7
3	Layout.....	8
3.1	Antenna Dimensions.....	8
3.2	Evaluation Board with Antenna .....	9
3.3	Solder Land Pattern .....	10
4	Frequency tuning.....	11
5	Packing .....	12
6	Notes .....	13
6.1	Typical Soldering Profile for Lead-free Process .....	13
6.2	Operating and storage conditions: .....	14
6.3	Installation guide: .....	14

# 1 Introduction

Unictron's CW325 chip antenna is designed for ISM 2.4GHz applications, covering frequencies 2400~2500 MHz. Fabricated with proprietary design and processes, CW325 shows excellent performance and is fully compatible with SMT processes which can decrease the assembly cost and improve device's quality and consistency.

## Features

- \* Stable and reliable in performances
- \* Low profile, compact size
- \* RoHS compliance
- \* SMT processes compatible

## Applications

- \* ISM 2.4 GHz applications
- \* ZigBee/BLE applications
- \* Bluetooth earphone systems
- \* Hand-held devices when WiFi / Bluetooth functions are needed, e.g., Smart phones
- \* IEEE802.11 b/g/n
- \* Wireless PCMCIA cards or USB dongles

## 2 Electrical Characteristics

### 2.1 Table with electrical properties:

Characteristics		Specifications	Unit
Outline Dimensions		3.2 x 1.6 x 1.6	mm
Working Frequency		2400 – 2500	MHz
VSWR (@ center frequency)*		2 Max.	
Characteristic Impedance		50	$\Omega$
Polarization		Linear Polarization	
Peak Gain	(@ 2442MHz)	1.9 (typical)	dBi
Efficiency		61 (typical)	%

\*Center frequency means the frequency with the lowest value in return loss of the chip antenna on the evaluation board.

## 2.2 Return Loss ( $S_{11}$ )

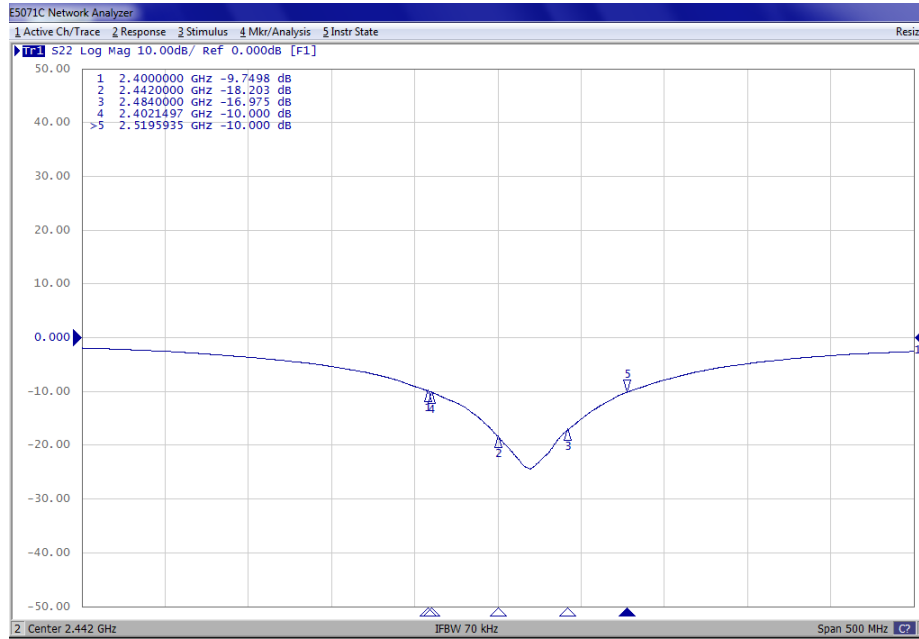

## 2.3 VSWR ( $S_{11}$ )

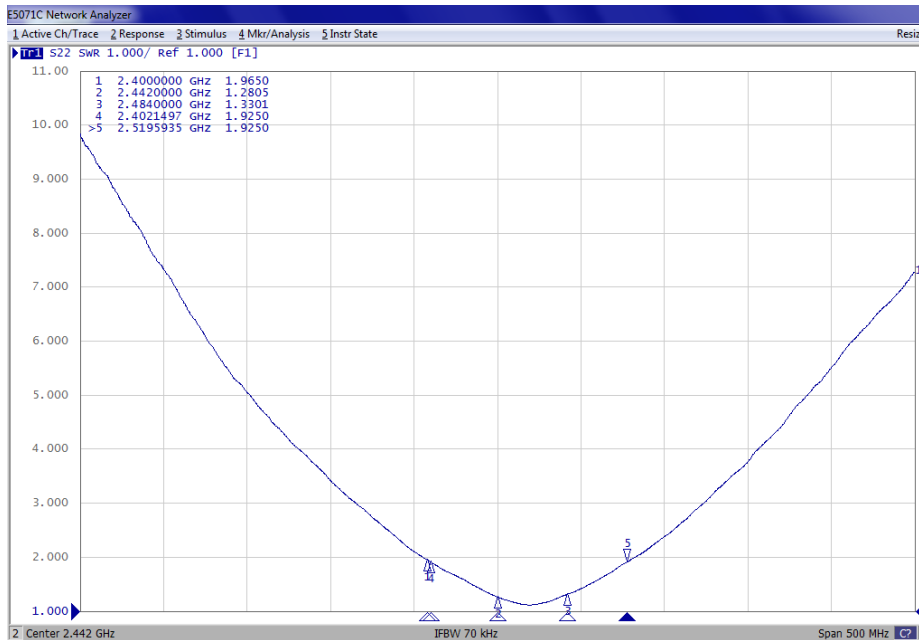

## 2.4 Efficiency Table

Frequency(MHz)	2400	2412	2417	2422	2427	2432	2437	2442	2447	2452	2457	2462	2467	2472	2484	2500
Efficiency(dB)	-2.5	-2.4	-2.3	-2.3	-2.2	-2.2	-2.1	-2.2	-2.1	-2.1	-2.0	-2.0	-2.0	-2.2	-2.2	-2.3
Efficiency(%)	56.0	57.4	58.9	59.4	59.8	60.1	61.1	60.8	61.8	62.4	62.8	63.4	62.8	60.8	60.0	58.7
Gain(dBi)	1.5	1.5	1.7	1.7	1.8	1.8	1.9	1.9	1.9	1.9	1.8	1.9	1.8	1.7	1.7	1.6

## 2.5 Efficiency vs. Frequency

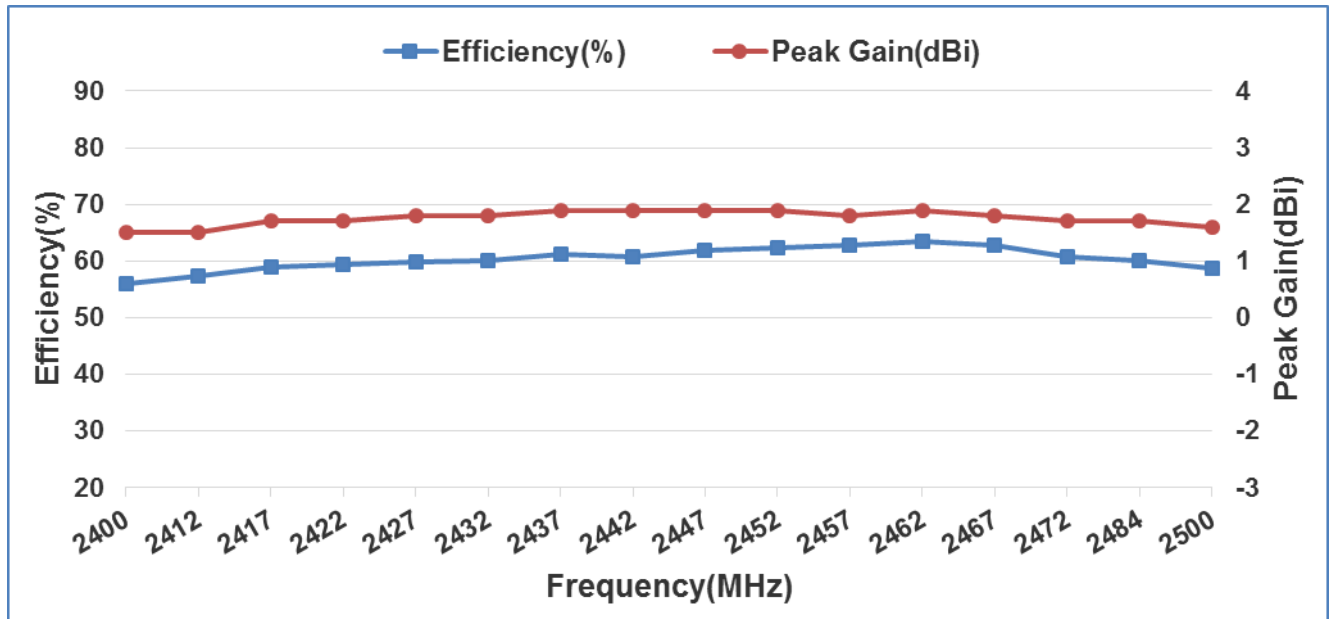

## 2.6 Radiation Pattern (with 40x40mm<sup>2</sup> Evaluation Board)

3D Gain Pattern @ 2442 MHz (unit: dBi)

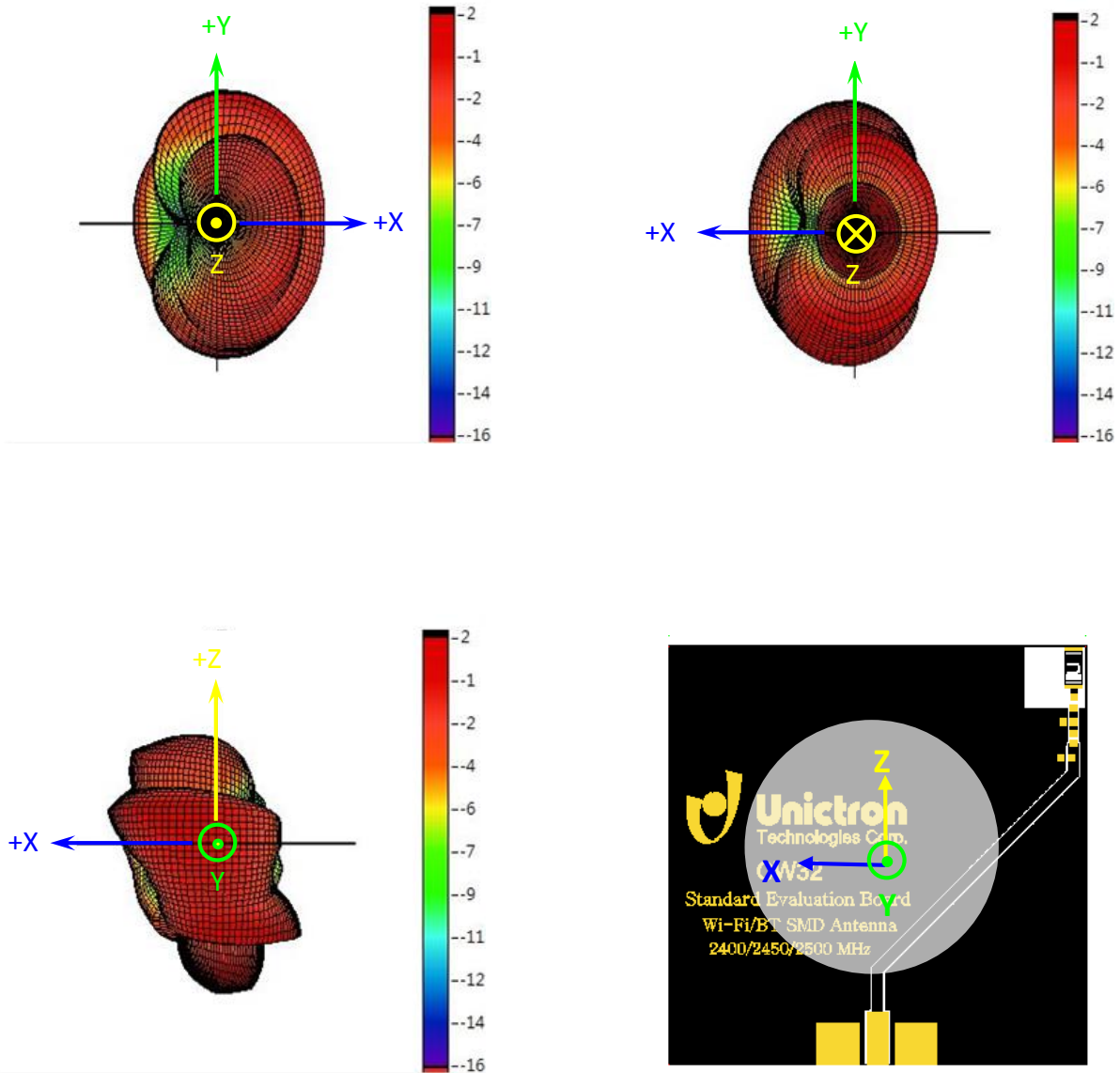

# 3 Layout

## 3.1 Antenna Dimensions

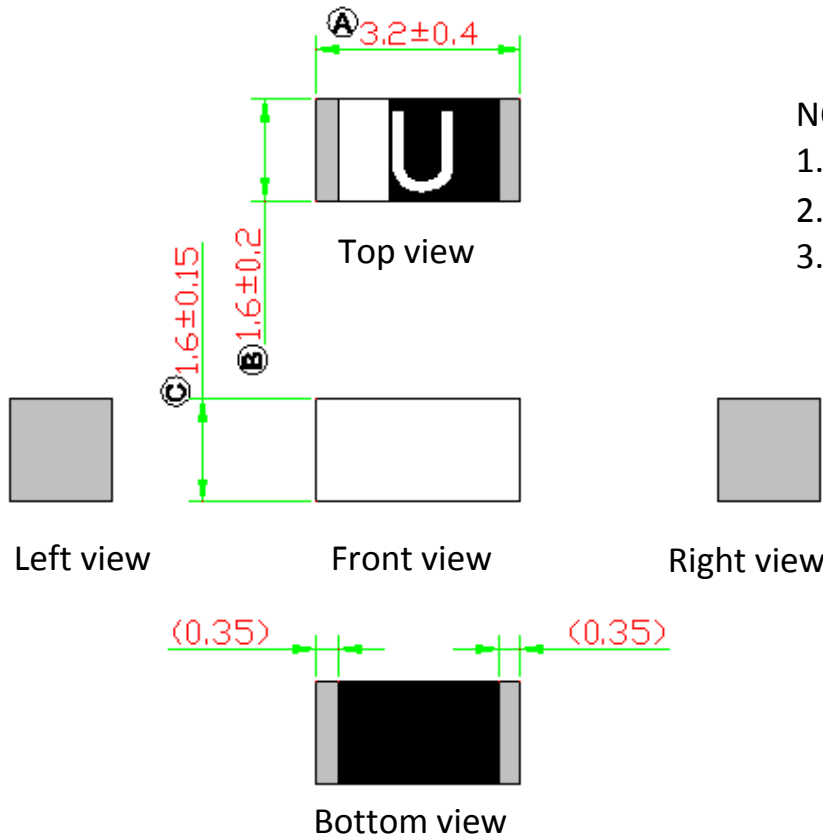

**NOTE:**

1. All materials are RoHS compliant
2. "Ⓐ - Ⓒ" Critical dimensions
3. "( )" Reference dimensions

Unit: mm

### PIN Definitions

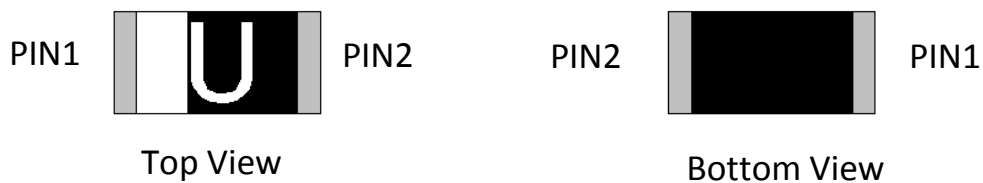

PIN	1	2
Soldering Pad	Signal	N/C



## 3.2 Evaluation Board with Antenna

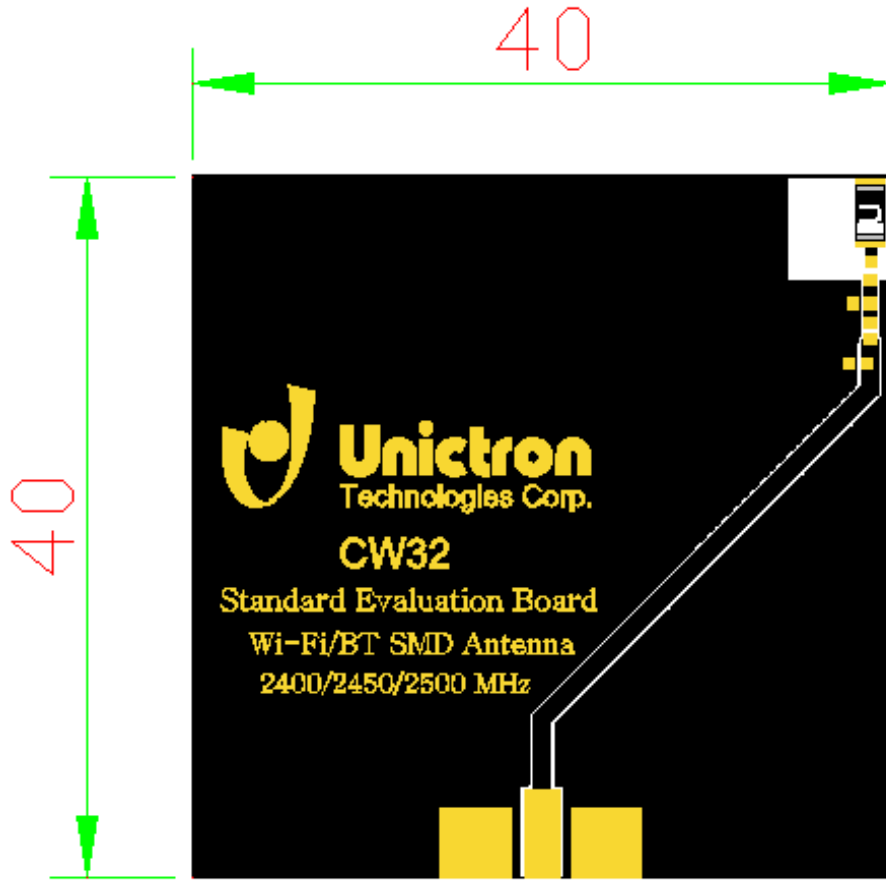

Unit: mm

### 3.3 Solder Land Pattern

The solder land pattern (gold marking areas) is shown below. Recommendation on matching circuit will be provided according to customer's installation conditions.

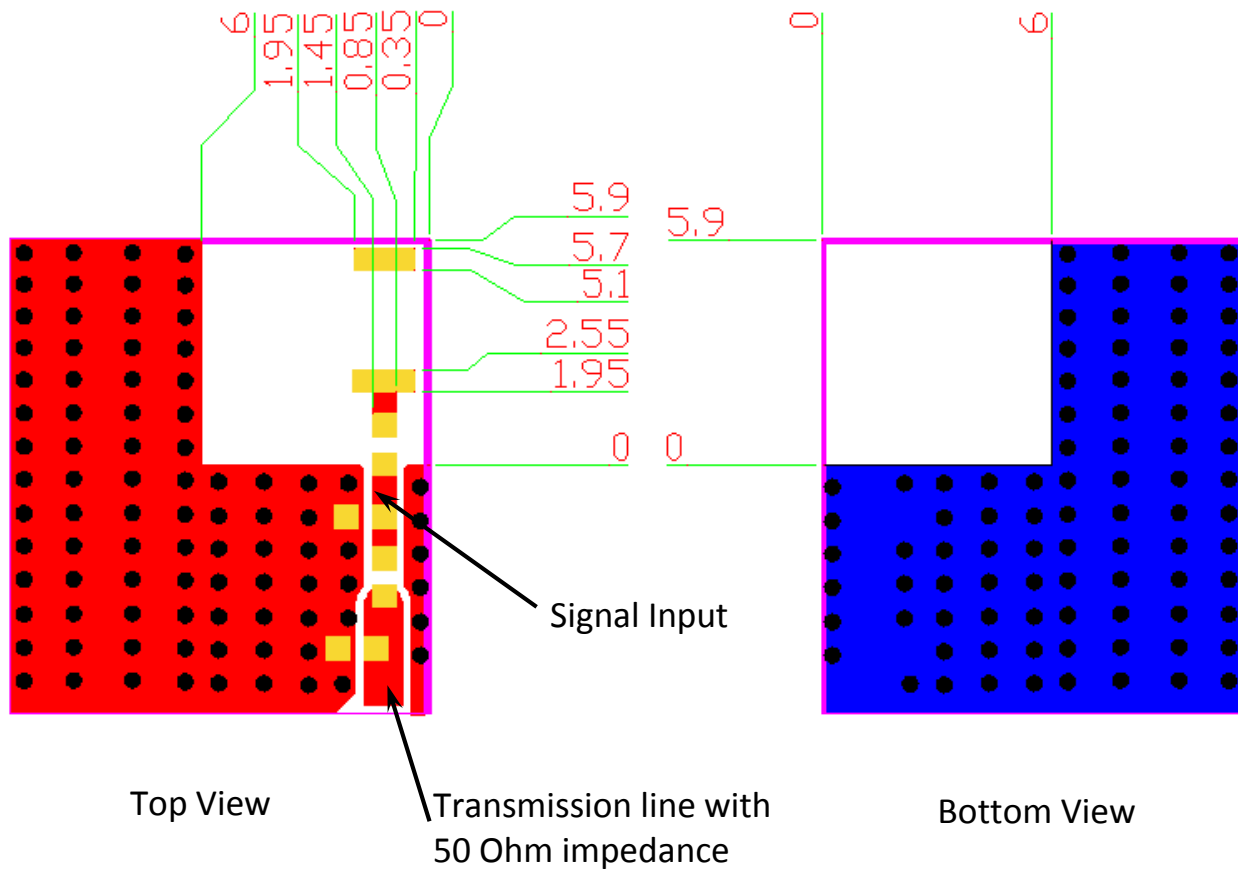

# 4 Frequency tuning

Chip antenna tuning scenario

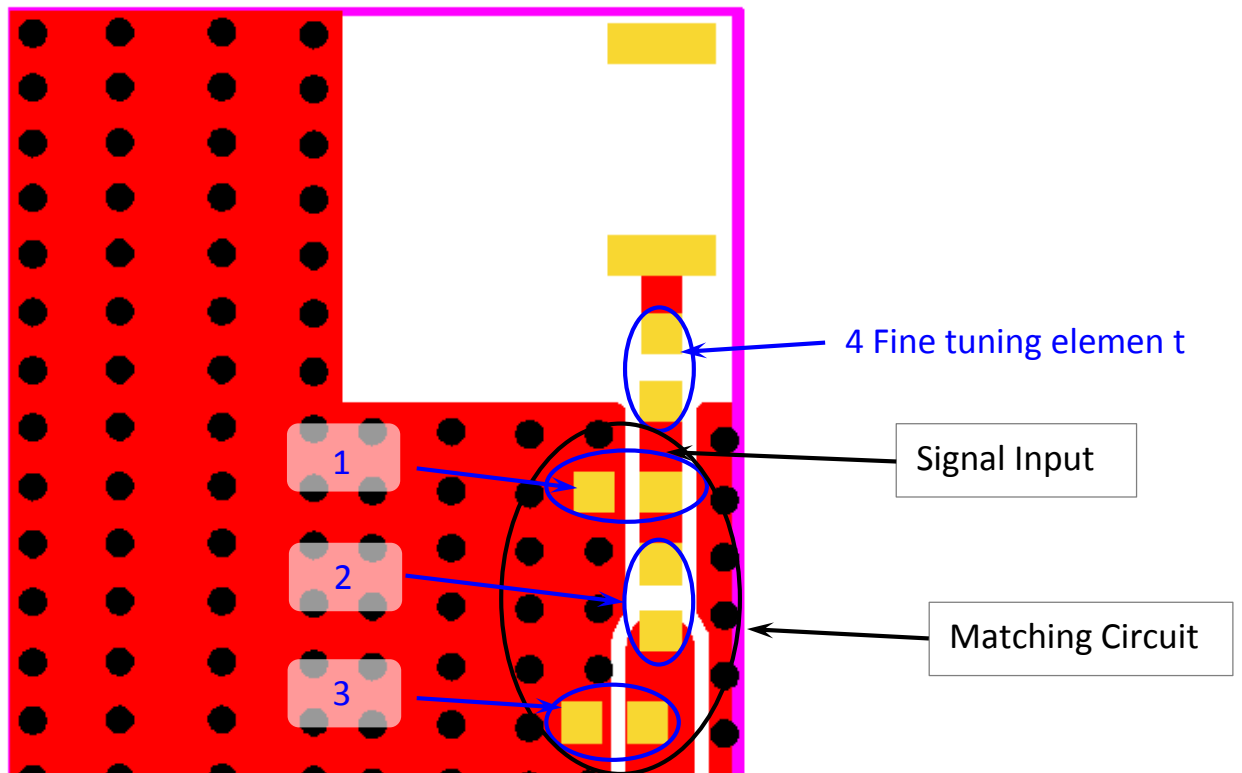

With the following recommended values of matching and tuning components, the center frequencies will be about 2442 MHz at out standard 40x40 mm<sup>2</sup> evaluation board. However, these are typical reference values which may need to be changed when circuit boards or part vendors are different.

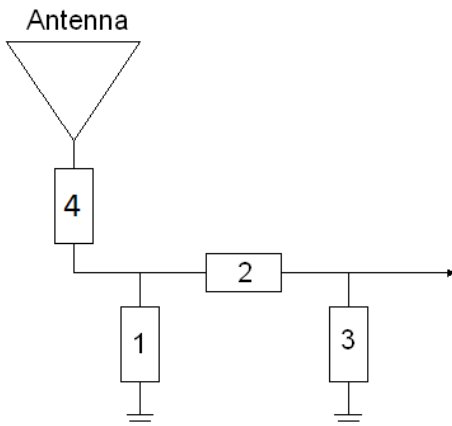

System Matching Circuit Component			
Location	Description	Vendor	Tolerance
1	N/A	-	-
2	0 Ω, (0402)	-	-
3	0.4 pF, (0402)	MURATA	±0.05 pF
4	8.2 nH, (0402)	MURATA	±2%
Fine tuning element			

# 5 Packing

1. Quantity/Reel: 2000 pcs/Reel
2. Plastic tape:

a) Tape drawing:

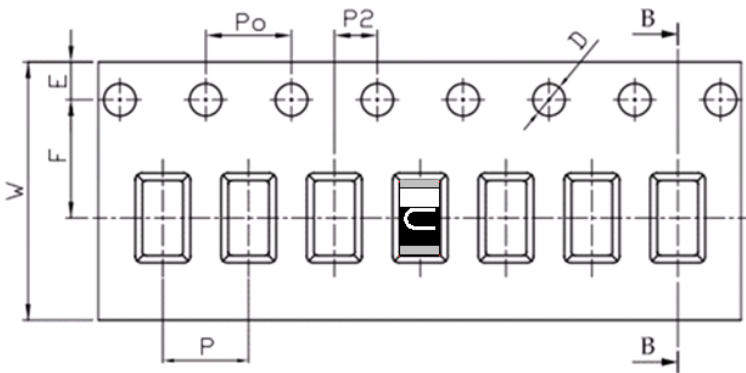

b) Tape dimensions (unit: mm)

Feature	Specifications	Tolerances
W	12.00	±0.30
P	4.00	±0.10
E	1.75	±0.10
F	5.50	±0.10
P2	2.00	±0.10
D	1.50	+0.10 -0.00
P0	4.00	±0.10
10P0	40.00	±0.20

# 6 Notes

## 6.1 Typical Soldering Profile for Lead-free Process

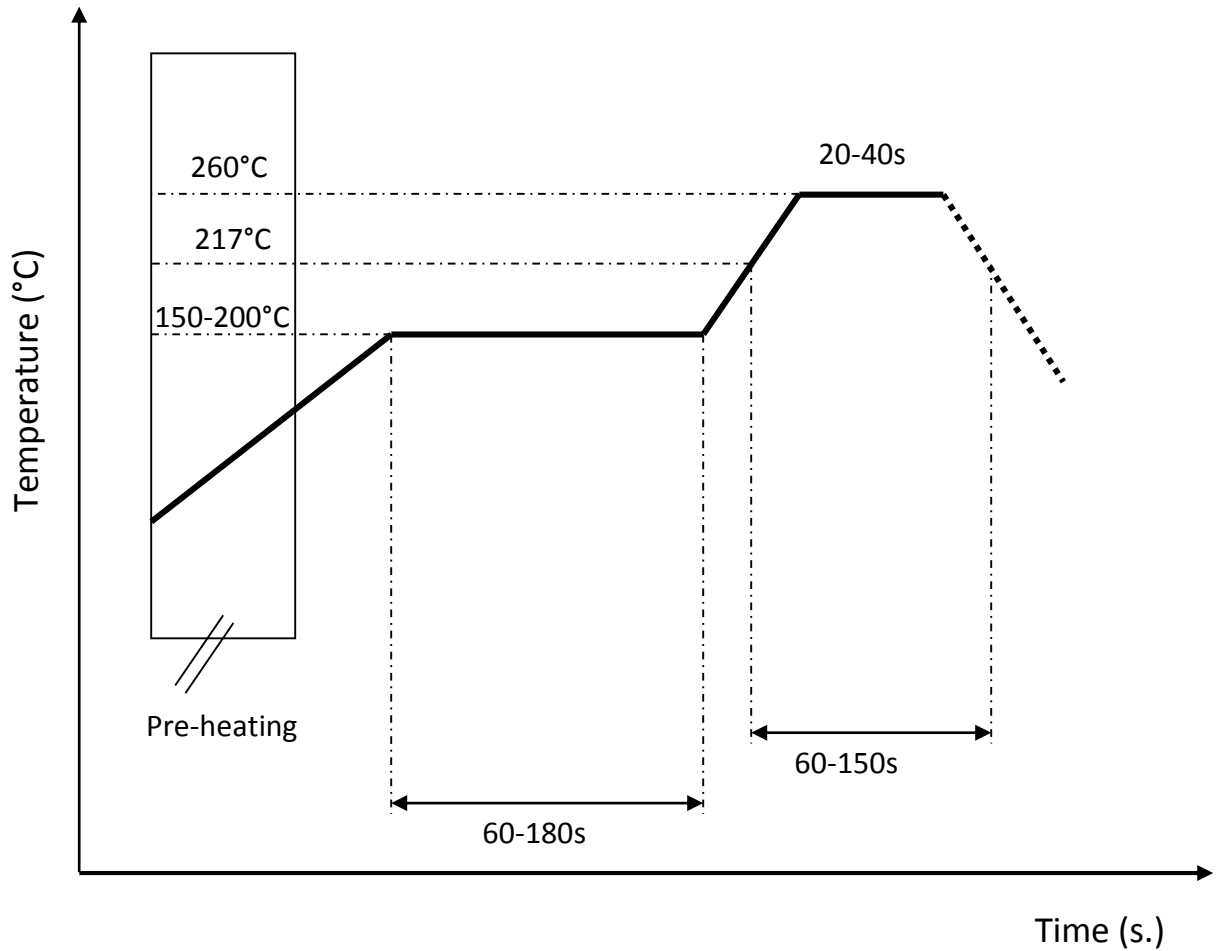

## 6.2 Operating and storage conditions:

### Operating:

Maximum Input Power: 2W

Operating Temperature: -40°C to +85°C

### Storage:

Storage Temperature -5°C to +40°C

Relative Humidity: 20% to 70%

Shelf Life: 1 year

## 6.3 Installation guide:

Request Unictron's application notes "General guidelines for the installation of Unictron's chip antennas" for further information at [e-sales@unictron.com](mailto:e-sales@unictron.com).

Presented data were measured on reference PCB (ground) as shown in this specification. When the antenna placement or size of the PCB is changed, antenna performance and values of matching components may differ from data shown here.

Information presented in this Reference Specification is believed to be correct as of the date of publishing. Unictron Technologies Corporation reserves the rights to change the Reference Specification without notice due to technical improvements, etc. Please consult with Unictron's engineering team about the latest information before using this product. Per request, we may provide advice and assistance in implementing this antenna to a customer's device by simulation or real measurement of the interested device in our testing facilities.

## Unictron Technologies Corporation

No. 41 Shuei-Keng, Guan-Si

Hsinchu 30648

Taiwan (R.O.C.)

**Tel:** +886-3-547-5550

**Email:** e-sales@unictron.com

**Web:** www.unictron.com