



Ultrasonic air transducer
Model: A300A
Part Number: H2KA300KA1CD00

Version 1.1

Date: 2018.Sep. 11

Table of Contents

1	Introduction.....	3
1.1	Model name.....	3
1.2	Part number.....	3
1.3	Marking.....	3
2	Electrical Characteristics.....	4
2.1	Major electrical characteristics and testing conditions.....	4
2.2	Performance testing.....	5
2.3	Typical directivity diagram.....	6
3	Dimensions.....	7
4	Operating and storage conditions.....	8
5	Packing.....	9
5.1	Inner box.....	9
5.2	Outer box.....	9
6	Notes and references.....	10
6.1	Piezoelectricity.....	10
6.2	Soldering.....	10
6.3	Electric connection.....	10
6.4	Installation.....	10
6.5	Not a water-proof device.....	10

1 Introduction

Unictron’s A300A ultrasonic transducer is designed to deliver outstanding performance at around 300 kHz frequency. The transducer works as a signal transmitting and receiving unit. This ultrasonic transducer is particularly suitable for double layer detection, edge detection and web guiding, splice detection, label detection and proximity measurement, etc. It will work reliably regardless of materials under detection, for example: paper, glass, transparent plastics, shiny metal, cardboard, etc.

1.1 Model name

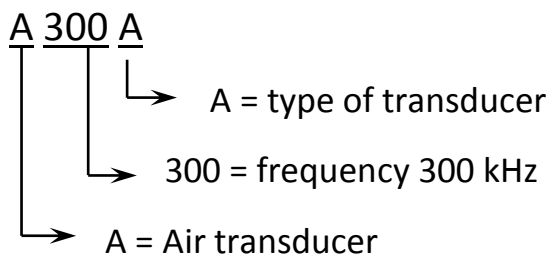

1.2 Part number

H2KA300KA1CD00

1.3 Marking

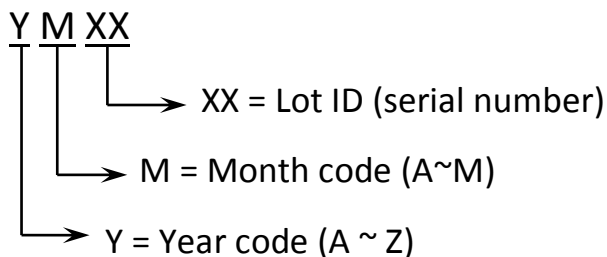

Year	Y code	Month	M code
2017	S	Jan	A
2018	T	Feb	B
2019	U	March	C
2020	V	April	D
2021	W	May	E
2022	X	June	F
2023	Y	July	G
2024	Z	August	H
2025	A	Sep	J
2026	B	Oct	K
2027	C	Nov	L
2028	D	Dec	M

2 Electrical Characteristics

2.1 Major electrical characteristics and testing conditions

Characteristics	Specifications	Unit
Operation frequency	300	kHz
Overall sensitivity *	min. 1.8	V _{p-p}
Capacitance (@ 1kHz, 1Vrms)	1300 ±20%	pF
Directivity (half angle @-6 dB)	5	Degree
Maximum driving voltage	50	V _{p-p}
Insulation Resistance (@ 100V DC)	100 (min.)	Mega Ohm

* Note: 1. Measured at 25±3°C, 45 to 60% RH.

2. Testing circuit setup: Driving signal: 10V_{p-p}, 300 kHz, burst number= 5 pulses, drive interval: 3.33ms, gain of receiving circuit: 60 dB (Please refer to 2.2 for details)
3. Dimensions of reflecting metal plate: 100x100mm, reflection distance: 100mm

2.2 Performance testing

Typical setup for sensitivity measurement

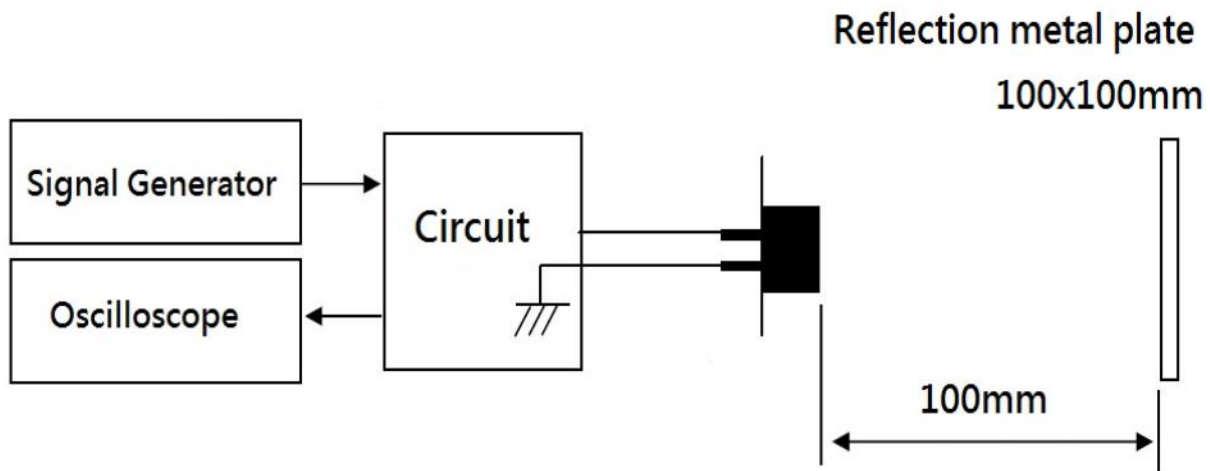

Measurement setup

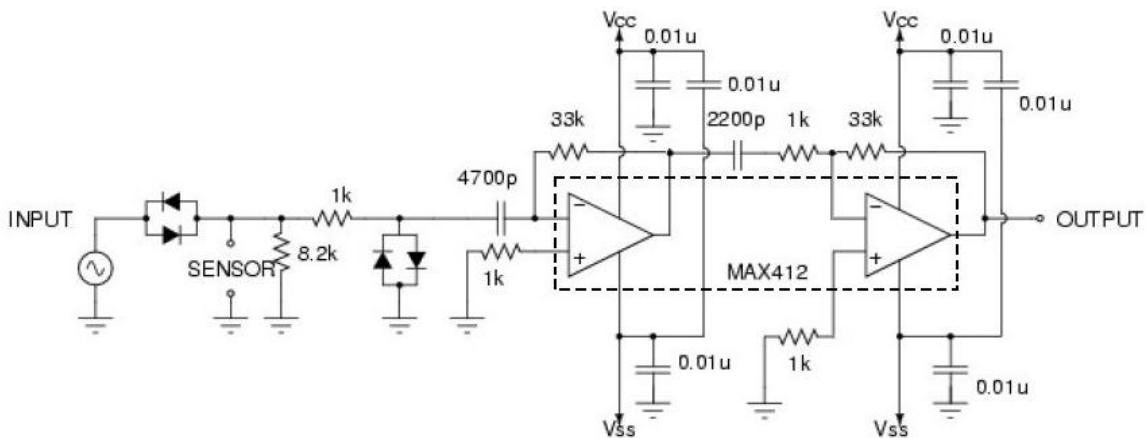

Circuit

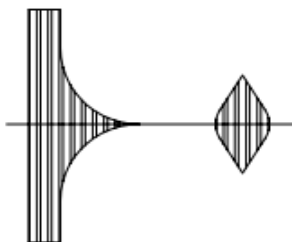

Drive signal:

10 Vp-p; Frequency=300 kHz; Driving Interval=3.33ms;
Pulse n=5; Gain of receiving circuit: 60 dB

2.3 Typical directivity diagram

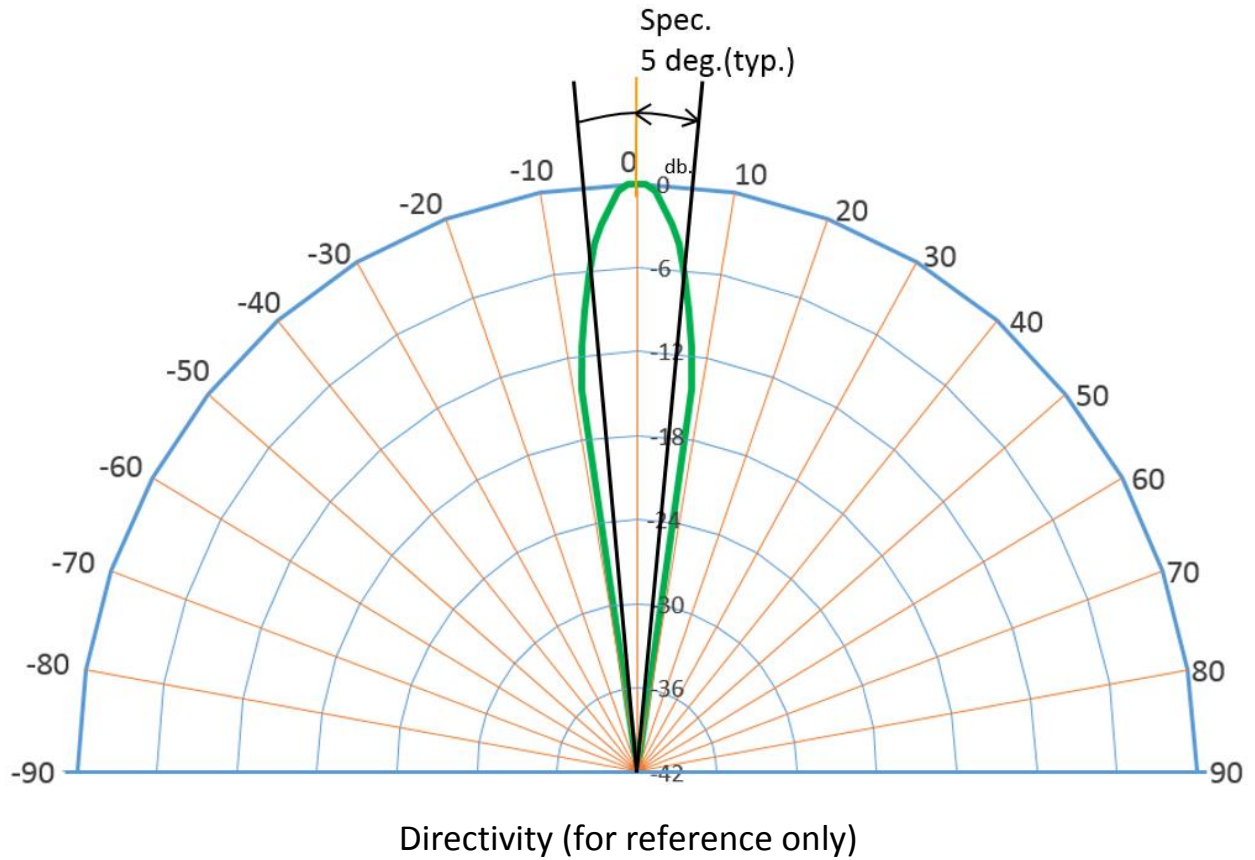

3 Dimensions

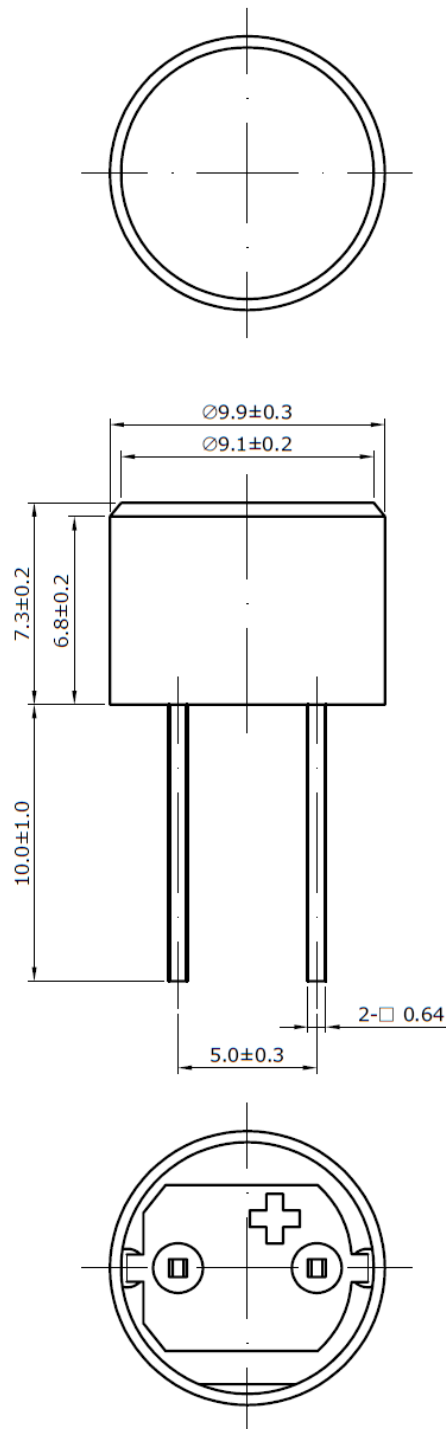

Unit: mm

4 Operating and storage conditions

Operating:

Temperature: -20°C to +70°C

Maximum driving voltage: 50 V_{p-p}

Storage:

Temperature: -30°C to +70°C

Relative Humidity: 30-80%

Storage area shall avoid sulfur-containing materials. Sulfur may cause corrosion of electrode metals.

5 Packing

5.1 Inner box

Dimensions	78 x 242 x 103mm
Quantity of transducers	540 pcs (90 pcs x 6 holders)

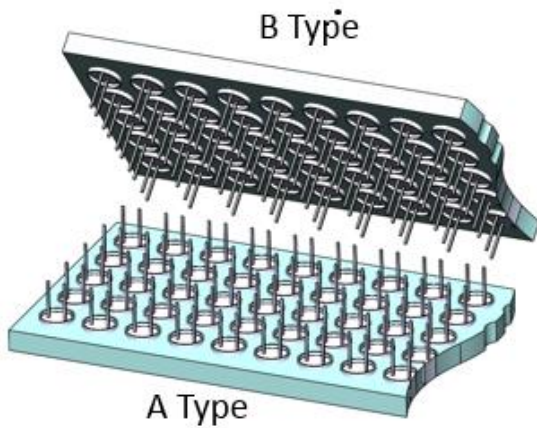

Ninety transducers in a holder

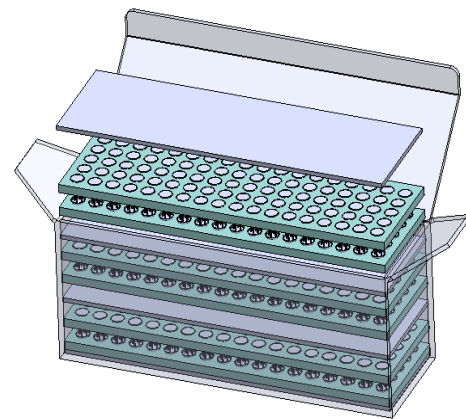

Six holders stacked in an inner box

5.2 Outer box

Dimensions	265 x 410 x 235mm
Quantity of inner box	10 boxes
Total quantity of transducers	5400 pcs

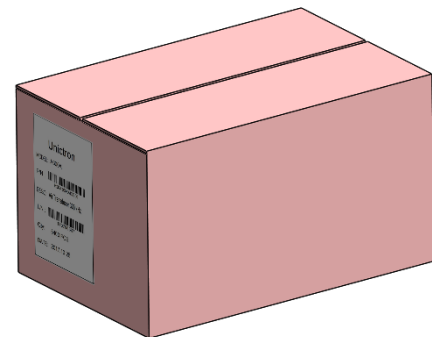
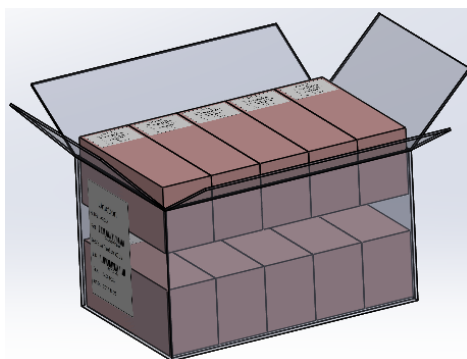

6 Notes and references

6.1 Piezoelectricity

When exposed to high temperature or high voltage, piezoceramic materials may lose its piezoelectric properties due to depolarization.

6.2 Soldering

Please use the soldering tip to mount the transducer onto circuit boards. The temperature of the soldering tip should not exceed 360°C with maximum soldering time of 3 seconds. The transducer is not designed for reflow soldering process. Do not put the transducer in the reflow oven.

6.3 Electric connection

Do not connect transducer to DC voltage.

6.4 Installation

Noise may be induced when the transducer is subject to vibration. Please protect the transducer with buffer material at installation.

6.5 Not a water-proof device

The transducer is not hermetically sealed. Please don't expose to water, organic solvents, and corrosive gases. Please also keep the surface of the transducer clean, do not touch the surface with skin and do not clean the surface with organic solvent.

Data presented in this specification were measured under the conditions specified above. When measuring conditions are different (e.g. relative humidity or ambient temperature), results may differ.

Information presented in this specification is believed to be correct as of the date of publishing. Unictron Technologies Corporation reserves the rights to change the specification without prior notice. Please consult Unictron's engineering team about the latest information before using this product.

Unictron Technologies Corporation

No. 41 Shuei-Keng, Guan-Si

Hsinchu 30648

Taiwan (R.O.C.)

Tel: +886-3-547-5550

Email: e-sales@unictron.com

Web: www.unictron.com