

Surface Mount PNP General Purpose Transistor



2N2907AUA (TX, TXV)

Features:

- Ceramic 4 pin surface mount package
- Miniature package to minimize circuit board area
- Hermetically sealed
- Processed per MIL-PRF-19500/291

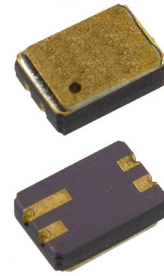

Description:

The 2N2907AUA (TX, TXV) is a hermetically sealed ceramic surface mount general purpose switching transistor. The miniature four pin ceramic package is ideal for designs where board space and device weight are important design considerations. The "UA" suffix denotes the 4 terminal leadless chip carrier package, type "A" per MIL-PRF-19500/291.

Typical screening per MIL-PRF-19500/291. The burn-in condition is $V_{CB} = 30\text{ V}$, $P_D = 400\text{ mW}$, $T_A = 25^\circ\text{ C}$, $t = 80\text{ hrs}$. Refer to MIL-PRF-19500/291 for complete requirements. In addition, the TX and TXV versions receive 100% thermal response testing.

When ordering parts without processing, do not use the TX or TXV suffix.

Applications:

- General switching
- Amplification
- Signal processing
- Radio transmission
- Logic gates

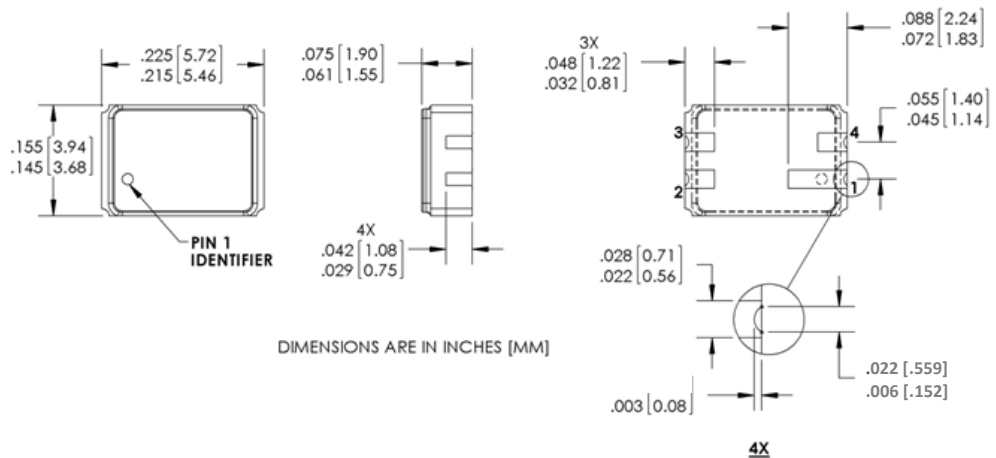

Pin	Function
1	Collector
2	Emitter
3	Base
4	No Connection

General Note

TT Electronics reserves the right to make changes in product specification without notice or liability. All information is subject to TT Electronics' own data and is considered accurate at time of going to print.

TT Electronics | OPTEK Technology
 1645 Wallace Drive, Carrollton, TX 75006 | Ph: +1 972 323 2200
www.ttelectronics.com | sensors@ttelectronics.com

Surface Mount PNP General Purpose Transistor



2N2907AUA (TX, TXV)

Electrical Specifications

Absolute Maximum Ratings ($T_A = 25^\circ\text{C}$ unless otherwise noted)

Collector-Base Voltage	60 V
Collector-Emitter Voltage	60 V
Emitter-Base Voltage	5.0 V
Collector Current-Continuous	600 mA
Operating Junction Temperature (T_J)	-65° C to +200° C
Storage Junction Temperature (T_{stg})	-65° C to +200° C
Power Dissipation @ $T_A = 25^\circ\text{C}$	0.5 W
Power Dissipation @ $T_c = 25^\circ\text{C}$	1.00 W ⁽¹⁾
Soldering Temperature (vapor phase reflow for 30 seconds)	215° C
Soldering Temperature (heated collet for 5 seconds)	260° C

Electrical Characteristics ($T_A = 25^\circ\text{C}$ unless otherwise noted)

SYMBOL	PARAMETER	MIN	MAX	UNITS	TEST CONDITIONS
OFF CHARACTERISTICS					
$V_{(BR)CBO}$	Collector-Base Breakdown Voltage	60		V	$I_C = 10\ \mu\text{A}, I_E = 0$
$V_{(BR)CEO}$	Collector-Emitter Breakdown Voltage	60		V	$I_C = 10\ \text{mA}, I_B = 0^{(2)}$
$V_{(BR)EBO}$	Emitter-Base Breakdown Voltage	5.0		V	$I_E = 10\ \mu\text{A}, I_C = 0$
I_{CBO}	Collector-Base Cutoff Current		10	μA	$V_{CB} = 50\ \text{V}, I_E = 0$
			10	μA	$V_{CB} = 50\ \text{V}, I_E = 0, T_A = 150^\circ\text{C}$
I_{EBO}	Emitter-Base Cutoff Current		10	μA	$V_{CE} = 4.0\ \text{V}, I_C = 0$
I_{CES}	Collector Emitter Cutoff Current		50	nA	$V_{EB} = 50\ \text{V}$
ON CHARACTERISTICS					
h_{FE}	Forward-Current Transfer Ratio	75		-	$V_{CE} = 10\ \text{V}, I_C = 0.1\ \text{mA}$
		100	450	-	$V_{CE} = 10\ \text{V}, I_C = 1.0\ \text{mA}$
		100		-	$V_{CE} = 10\ \text{V}, I_C = 10\ \text{mA}$
		100	300	-	$V_{CE} = 10\ \text{V}, I_C = 150\ \text{mA}^{(2)}$
		50		-	$V_{CE} = 10\ \text{V}, I_C = 500\ \text{mA}^{(2)}$
		50		-	$V_{CE} = 10\ \text{V}, I_C = 1.0\ \text{mA}, T_A = -55^\circ\text{C}$

Note:

- Derate linearly 6.6 mW/°C above 25° C
- Pulse Width $\leq 300\ \mu\text{s}$, Duty Cycle $\leq 2.0\%$

General Note

TT Electronics reserves the right to make changes in product specification without notice or liability. All information is subject to TT Electronics' own data and is considered accurate at time of going to print.

TT Electronics | OPTEK Technology
1645 Wallace Drive, Carrollton, TX 75006 | Ph: +1 972 323 2200
www.ttelectronics.com | sensors@ttelectronics.com

Surface Mount PNP General Purpose Transistor



2N2907AUA (TX, TXV)

Electrical Specifications

Electrical Characteristics ($T_A = 25^\circ\text{C}$ unless otherwise noted)

SYMBOL	PARAMETER	MIN	MAX	UNITS	TEST CONDITIONS
OFF CHARACTERISTICS					
$V_{CE(SAT)}$	Collector-Emitter Saturation Voltage		0.40	V	$I_C = 150\text{ mA}, I_B = 15\text{ mA}^{(2)}$
			1.60	V	$I_C = 500\text{ mA}, I_B = 50\text{ mA}^{(2)}$
$V_{BE(SAT)}$	Base-Emitter Saturation Voltage		1.30	V	$I_C = 150\text{ mA}, I_B = 15\text{ mA}^{(2)}$
			2.60	V	$I_C = 500\text{ mA}, I_B = 50\text{ mA}^{(2)}$
SMALL-SIGNAL CHARACTERISTICS					
$ h_{fe} $	Small Signal Forward Current Transfer Ratio	100		-	$V_{CE} = 10\text{ V}, I_C = 1.0\text{ mA}, f = 1.0\text{ kHz}$
$ h_{fe} $	Small Signal Forward Current Transfer Ratio	2.0		-	$V_{CE} = 20\text{ V}, I_C = 20\text{ mA}, f = 100\text{ MHz}$
C_{obo}	Open Circuit Output Capacitance		8.0	pF	$V_{CB} = 10\text{ V}, 100\text{ kHz} \leq f \leq 1.0\text{ MHz}$
C_{ibo}	Input Capacitance (Output Open)		30	pF	$V_{EB} = 2.0\text{ V}, 100\text{ kHz} \leq f \leq 1.0\text{ MHz}$
SWITCHING CHARACTERISTICS					
t_{on}	Turn-On Time		45	ns	$V_{CC} = 30\text{ V}, I_C = 150\text{ mA}, I_{B1} = 15\text{ mA}$
t_{off}	Turn-Off Time		300	ns	$V_{CC} = 30\text{ V}, I_C = 150\text{ mA}, I_{B1} = I_{B2} = 15\text{ mA}$

General Note

TT Electronics reserves the right to make changes in product specification without notice or liability. All information is subject to TT Electronics' own data and is considered accurate at time of going to print.

TT Electronics | OPTeK Technology
 1645 Wallace Drive, Carrollton, TX 75006 | Ph: +1 972 323 2200
www.ttelectronics.com | sensors@ttelectronics.com