

Non-Contacting Hall Effect Single Turn Position Sensor



6120 Series

Features:

- 7/8" diameter
- Non-contacting
- Hall Effect
- Single turn
- Multiple styles available
- Custom models available



Description:

The BI Technologies line of single-turn non-contacting hall-effect position sensors is 7/8" in diameter. Custom models are available. The hall-effect technology used makes this set of position sensors ideal for harsh environments where shock levels, vibration and temperature.

Applications:

- Industrial grade joystick
- HVAC controls

Model Styles Available

6121	1/8" Shaft, 1/4" Bushing
6126	1/8" Shaft, 3/8" Bushing
6127	1/4" Shaft, 3/8" Bushing
612x-XXXX	Custom models are available; Contact Customer Service for special features

Ordering Information

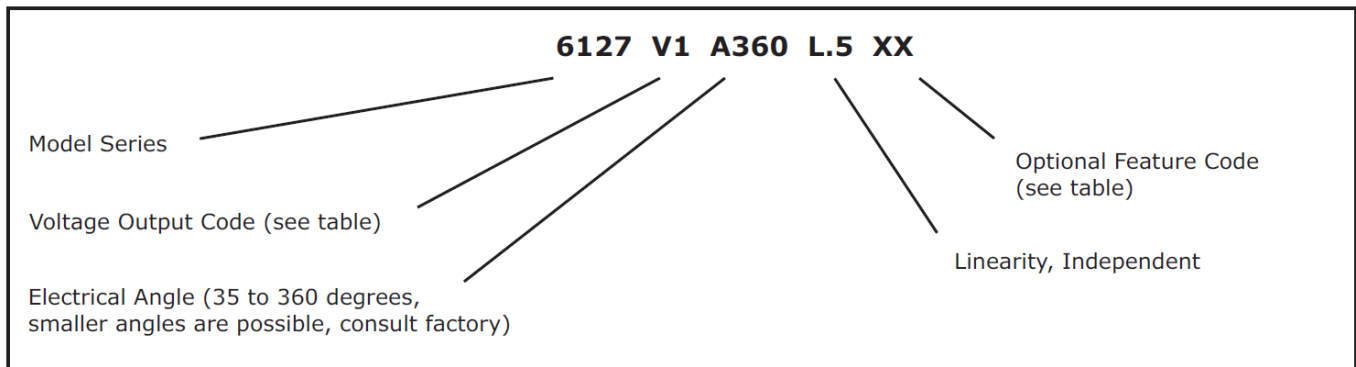

General Note
 TT Electronics reserves the right to make changes in product specification without notice or liability. All information is subject to TT Electronics' own data and is considered accurate at time of going to print.

© TT electronics plc

TT Electronics | BI Technologies
 413 Rood RD, Suite 7
 Calexico, CA 92231
 Ph: +1 714 447 2345
www.ttelectronics.com/bi-technologies

Non-Contacting Hall Effect Single Turn Position Sensor



6120 Series

Electrical Specifications¹

Output voltage	0.25 Vdc to 4.75 Vdc typical (see Feature Codes table)
Output overvoltage limits	10 Vdc to -0.3 Vdc; output may be shorted to ground or supply without damage
Output current	±8 mA max.
Output load	1 kΩ min., 10 kΩ typical
Input voltage	4.5 to 5.5 Vdc
Supply voltage absolute limits	20 Vdc max., -10 Vdc min.
Independent linearity ²	±0.5% (0.25% available)
Hysteresis	0.2% max.
Resolution	0.088° for 360° travel, 0.011° for 45° travel
Supply current	7.5 mA typical, 11 mA max.
Dielectric strength	750 V rms
Insulation resistance	1,000 megΩ min.
Electrostatic discharge (ESD)	Passes 2 kV human body model and 15 kV air discharge
Bulk current injection (BCI)	Passes 2-500 MHz at 200 mA
Actual electrical travel	360° typical (see ordering information)
Temperature coefficient of output voltage	±20 ppm/°C

Mechanical Specifications

Total mechanical travel	360° continuous (320° with stop feature)
Bearing	Bearing bronze bushing
Weight	0.6 oz. typical
Static stop strength	40 in. oz.
Panel nut tightening torque	25 in. lb. max.
Supply voltage absolute limits	20 Vdc max., -10 Vdc min.
Independent linearity	±0.5% (0.25% available)
Hysteresis	0.2% max.
Resolution	0.088° for 360° travel, 0.011° for 45° travel

¹ Specifications subject to change without notice.

² Linearity is measured between 1% and 99% of input voltage.

Non-Contacting Hall Effect Single Turn Position Sensor



6120 Series

Environmental Specifications

Operating temperature range	-40°C to +125°C
Shock	Per MIL R-39023, 6 ms saw-tooth 100 G's
Vibration	Per MIL R-39023, 10 G's, 100 to 500 Hz
Moisture resistance, powered	Per MIL 202G, method 106G
Rotational life	10 million shaft revolutions
Storage temperature range	-55°C to +125°C

Feature Codes

Voltage Output Codes		Optional Feature Codes	
V0	≤ 0.15 Vdc to ≥ 4.8 Vdc	ST	Stop (320°)
V1	0.2 Vdc to 4.8 Vdc	FS	Flatted Shaft (slot standard)
V2	0.25 Vdc to 4.75 Vdc	LT	Linearity Data
V3	0.5 Vdc to 4.5 Vdc	SL	Shaft Lock
V4	0.75 Vdc to 4.25 Vdc	CW	Reverse Direction
V5	1 Vdc to 4 Vdc		

When V0 is used the angle specified is the theoretical angle over which the output would vary if the output could actually reach 0% and 100% of Vcc.

General Note
 TT Electronics reserves the right to make changes in product specification without notice or liability. All information is subject to TT Electronics' own data and is considered accurate at time of going to print.

TT Electronics | BI Technologies
 413 Rood RD, Suite 7
 Calexico, CA 92231
 Ph: +1 714 447 2345
www.ttelectronics.com/bi-technologies

Non-Contacting Hall Effect Single Turn Position Sensor



6120 Series

Outline Drawings

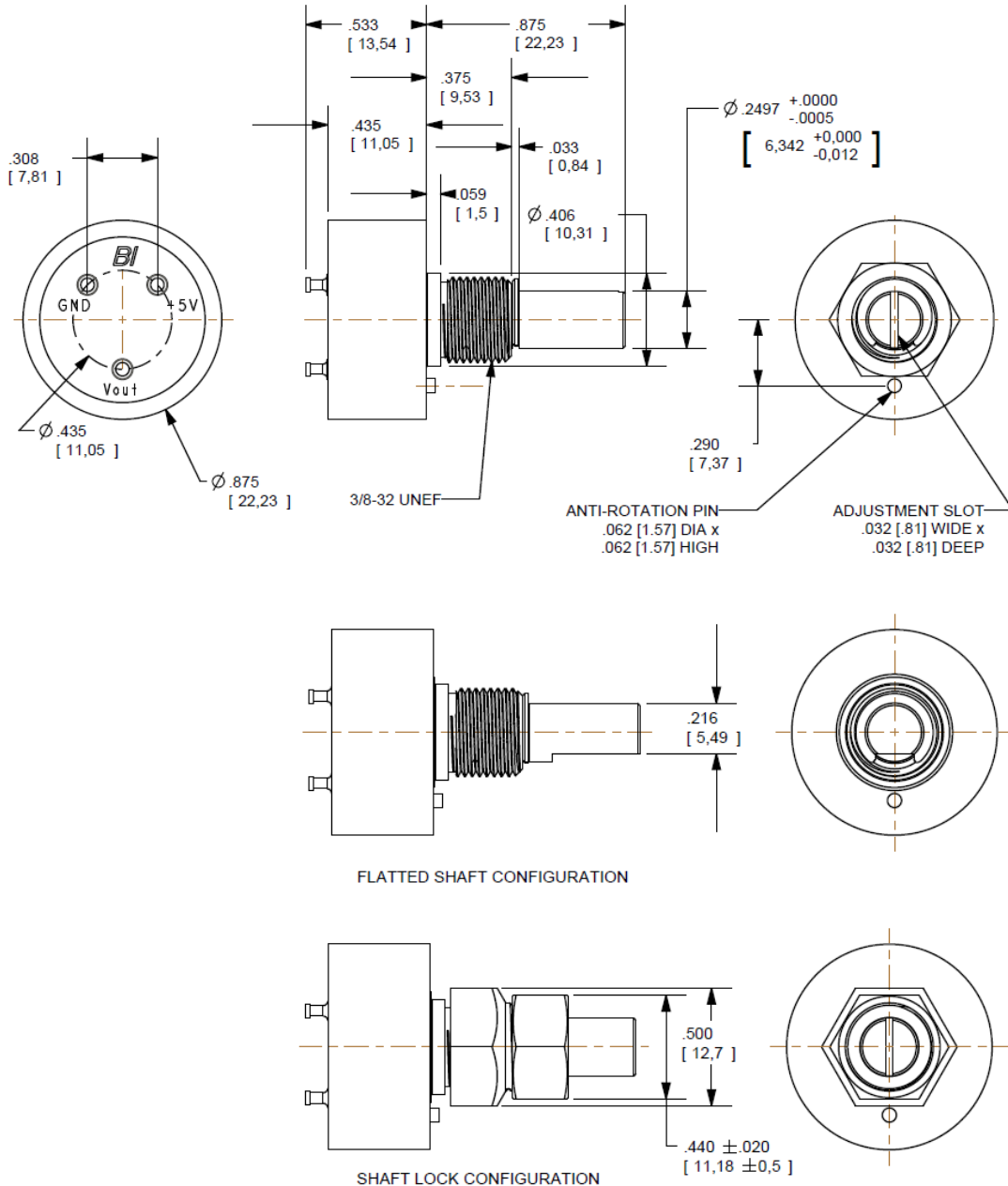

- NOTES:
1. UNIT SHIPS WITH NUT AND WASHER (NOT SHOWN).
 2. FOR SLOTTED OR FLATTED SHAFT, OUTPUT IS AT 50% IN POSITION SHOWN.
 3. DIMENSIONS: INCHES [mm].
 4. TOLERANCES: ± 0.015 [0.38] UNLESS NOTED.

General Note
 TT Electronics reserves the right to make changes in product specification without notice or liability. All information is subject to TT Electronics' own data and is considered accurate at time of going to print.

© TT electronics plc

TT Electronics | BI Technologies
 413 Rood RD, Suite 7
 Calexico, CA 92231
 Ph: +1 714 447 2345
www.ttelectronics.com/bi-technologies