

- Compact metal package
- Ultra wide 4:1 input voltage ranges
9–36, 18–75, 43–160 VDC
- EN 50155 approval for railway applications
- Very high efficiency up to 91%
- No minimum load
- Soft start
- Under voltage lock-out circuit
- Adjustable output voltage +10 / -20%
- Sense line



The TEP 200WIR Series is a family of isolated high performance DC/DC converter modules with ultra-wide 4:1 input voltage ranges. They come in rugged, sealed industry standard half brick package. A very high efficiency allows full power operation at 25°C with only 100 LFM air flow cooling and operation at 60°C with only 40% power derating. The very wide input voltage range and reverse input voltage protection make these converters interesting solution for battery operated systems. Typical applications are in telecom/datacom, industry control and railway systems for onboard power distribution.

Models				
Order Code	Input Voltage Range	Output Voltage nom.	Output Current max.	Efficiency typ.
TEP 200-2412WIR	9 - 36 VDC (24 VDC nom.)	12 VDC	15'000 mA	89 %
TEP 200-2413WIR		15 VDC	12'000 mA	90 %
TEP 200-2415WIR		24 VDC	7'500 mA	90 %
TEP 200-2416WIR		28 VDC	6'500 mA	90 %
TEP 200-2418WIR		48 VDC	3'700 mA	89 %
TEP 200-4812WIR	18 - 75 VDC (48 VDC nom.)	12 VDC	18'000 mA	90 %
TEP 200-4813WIR		15 VDC	14'000 mA	91 %
TEP 200-4815WIR		24 VDC	9'000 mA	90 %
TEP 200-4816WIR		28 VDC	7'500 mA	91 %
TEP 200-4818WIR		48 VDC	4'500 mA	90 %
TEP 200-7212WIR	43 - 160 VDC (110 VDC nom.)	12 VDC	20'000 mA	89 %
TEP 200-7213WIR		15 VDC	16'000 mA	90 %
TEP 200-7215WIR		24 VDC	10'000 mA	89 %
TEP 200-7216WIR		28 VDC	8'500 mA	90 %
TEP 200-7218WIR		48 VDC	5'000 mA	89 %

Options

TEP-HS1	- Optional Heat Sink: www.tracopower.com/products/tep-hs1.pdf
on demand (backorder with MOQ non stocking item)	<ul style="list-style-type: none"> - Optional model with 3.3 VDC / 50'000 mA Output and 9 - 36 VDC Input - Optional model with 5 VDC / 36'000 mA Output and 9 - 36 VDC Input - Optional model with 3.3 VDC / 50'000 mA Output and 18 - 75 VDC Input - Optional model with 5 VDC / 40'000 mA Output and 18 - 75 VDC Input - Optional model with 53 VDC / 3'800 mA Output and 33 - 75 VDC Input - Optional model with 3.3 VDC / 57'000 mA Output and 43 - 160 VDC Input - Optional model with 5 VDC / 44'000 mA Output and 43 - 160 VDC Input - 2:1 Input models - Negative (passive = Off) Remote On/Off function - Sync pin to synchronize switching frequency of up to 3 units (EMC reason)

Input Specifications

Input Current	- At no load	24 Vin models: 35 mA typ. 48 Vin models: 20 mA typ. 110 Vin models: 10 mA typ.
Surge Voltage		24 Vin models: 50 VDC max. (1 s max.) 48 Vin models: 100 VDC max. (1 s max.) 110 Vin models: 185 VDC max. (1 s max.)
Under Voltage Lockout		24 Vin models: 7.3 VDC min. / 7.7 VDC typ. / 8.1 VDC max. 48 Vin models: 15.5 VDC min. / 16 VDC typ. / 16.3 VDC max. 110 Vin models: 33 VDC min. / 34.5 VDC typ. / 36 VDC max.
Recommended Input Fuse		24 Vin models: 32'000 mA (fast acting) 48 Vin models: 20'000 mA (fast acting) 110 Vin models: 10'000 mA (fast acting) (The need of an external fuse has to be assessed in the final application.)
Input Filter		Internal Pi-Type

Output Specifications

Output Voltage Adjustment		-20% to +10% (By external trim resistor) See application note: www.tracopower.com/overview/tep200wir Output power must not exceed rated power!
Voltage Set Accuracy		±1% max.
Regulation	- Input Variation (Vmin - Vmax) - Load Variation (0 - 100%)	0.1% max. 0.1% max.
Ripple and Noise (20 MHz Bandwidth)		3.3 Vout models: 75 mVp-p max. (w/ 1 µF X7R // 25 µF poscap) 5 Vout models: 75 mVp-p max. (w/ 1 µF X7R // 25 µF poscap) 12 Vout models: 100 mVp-p max. (w/ 1 µF X7R // 25 µF poscap) 15 Vout models: 100 mVp-p max. (w/ 1 µF X7R // 25 µF poscap) 24 Vout models: 200 mVp-p max. (w/ 4.7 µF X7R) 28 Vout models: 200 mVp-p max. (w/ 4.7 µF X7R) 48 Vout models: 300 mVp-p max. (w/ 2.2 µF X7R)

All specifications valid at nominal voltage, full load and +25°C after warm-up time unless otherwise stated.

Capacitive Load	- 24 Vin input	3.3 Vout models: 151'000 µF max. 5 Vout models: 72'000 µF max. 12 Vout models: 12'500 µF max. 15 Vout models: 8'000 µF max. 24 Vout models: 3'100 µF max. 28 Vout models: 2'300 µF max. 48 Vout models: 770 µF max.
	- 48 Vin input	3.3 Vout models: 151'000 µF max. 5 Vout models: 80'000 µF max. 12 Vout models: 15'000 µF max. 15 Vout models: 9'300 µF max. 24 Vout models: 3'700 µF max. 28 Vout models: 2'600 µF max. 48 Vout models: 930 µF max.
	- 110 Vin input	3.3 Vout models: 172'000 µF max. 5 Vout models: 88'000 µF max. 12 Vout models: 16'600 µF max. 15 Vout models: 10'600 µF max. 24 Vout models: 4'100 µF max. 28 Vout models: 3'000 µF max. 48 Vout models: 1'000 µF max.
	Minimum Load	Not required
	Temperature Coefficient	±0.02 %/K max.
	Start-up Time	75 ms typ.
	Short Circuit Protection	Continuous, Automatic recovery
	Output Current Limitation	120 - 150% of Iout max.
	Oversvoltage Protection	115 - 130% of Vout nom.
Transient Response	- Response Time	200 µs typ. / 250 µs max. (25% Load Step)

Safety Specifications

Safety Standards	- IT / Multimedia Equipment	EN 60950-1 IEC 60950-1 UL 60950-1
	- Railway Applications	EN 50155
	- Certification Documents	www.tracopower.com/overview/tep200wir
Pollution Degree		PD 2
Over Voltage Category		OVC II

EMC Specifications

EMI Emissions	- Conducted Emissions	EN 55011 class B (with external filter) EN 55032 class B (with external filter)
	- Radiated Emissions	EN 55011 class B (with external filter) EN 55032 class B (with external filter)
	External filter proposal:	www.tracopower.com/overview/tep200wir
EMS Immunity		EN 50155 (Railway Applications) EN 50121-3-2 (EMC for Rolling Stock)
	- Electrostatic Discharge	Air: EN 61000-4-2, ±8 kV, perf. criteria A Contact: EN 61000-4-2, ±6 kV, perf. criteria A
	- RF Electromagnetic Field	EN 61000-4-3, 20 V/m, perf. criteria A
	- EFT (Burst) / Surge	EN 61000-4-4, ±2 kV, perf. criteria A EN 61000-4-5, ±2 kV, perf. criteria A
		Ext. input component: 24 & 48 Vin models: 2 x KY 20 µF 110 Vin models: 2 x KXJ 150 µF
	- Conducted RF Disturbances	EN 61000-4-6, 10 Vrms, perf. criteria A
	- PF Magnetic Field	Continuous: EN 61000-4-8, 100 A/m, perf. criteria A 1 s: EN 61000-4-8, 1000 A/m, perf. criteria A

All specifications valid at nominal voltage, full load and +25°C after warm-up time unless otherwise stated.

General Specifications

Relative Humidity		95% max. (non condensing)
Temperature Ranges	- Operating Temperature - Case Temperature - Storage Temperature	-40°C to +75°C +105°C max. -55°C to +125°C
Power Derating	- High Temperature	See application note: www.tracopower.com/overview/tep200wir
Over Temperature Protection Switch Off	- Protection Mode - Measurement Point	115°C typ. (Automatic recovery at 105°C typ.) Base-Plate
Cooling System		Natural convection (20 LFM)
Sense Function		10% max. of Vout nom. (Sense line to be connected to the output either at the module or at the load under regard of polarity.)
Remote Control	- Voltage Controlled Remote - Off Idle Input Current - Remote Pin Input Current	On: 3.0 to 12 VDC or open circuit Off: 0 to 1.2 VDC or short circuit Refers to 'Remote' and '-Vin' Pin 3 mA typ. -0.5 to 1.0 mA
Altitude During Operation		2'000 m max.
Switching Frequency		225 - 275 kHz (PWM) 250 kHz typ. (PWM)
Insulation System		Reinforced Insulation
Isolation Test Voltage	- Input to Output, 60 s - Input to Case, 60 s - Output to Case, 60 s	3'000 VAC (110 Vin models) 3'000 VDC (other models) 1'500 VAC (110 Vin models) 1'600 VDC (other models) 1'500 VAC (110 Vin models) 1'600 VDC (other models)
Isolation Resistance	- Input to Output, 500 VDC	1'000 MΩ min.
Isolation Capacitance	- Input to Output, 100 kHz, 1 V	2'500 pF max.
Reliability	- Calculated MTBF	300'000 h (MIL-HDBK-217F, ground benign)
Environment	- Vibration - Mechanical Shock - Thermal Shock	MIL-STD-810F EN 61373 MIL-STD-810F EN 61373 MIL-STD-810F
Housing Material		Alu base-plate w. plastic case (110 Vin models) Alu base-plate w. metal case (other models)
Base Material		Non-conductive FR4 (UL94 V-0 rated) (24 Vin & 48 Vin models only)
Potting Material		Silicone (UL 94 V-0 rated)
Pin Material		Copper
Pin Foundation Plating		Nickel (2 - 3 μm)
Pin Surface Plating		Tin (3 - 5 μm), matte
Connection Type		THD (Through-Hole Device)
Weight		105 g
Thermal Impedance		6.1 K/W 4.6 K/W (with Heat Sink)
Environmental Compliance	- Reach - RoHS - Flammability (EN 45545-2)	www.tracopower.com/info/reach-declaration.pdf www.tracopower.com/info/rohs-declaration.pdf www.tracopower.com/info/en45545-declaration.pdf

Supporting Documents

Overview Link (for additional Documents)	www.tracopower.com/overview/tep200wir
--	--

All specifications valid at nominal voltage, full load and +25°C after warm-up time unless otherwise stated.

Outline Dimensions

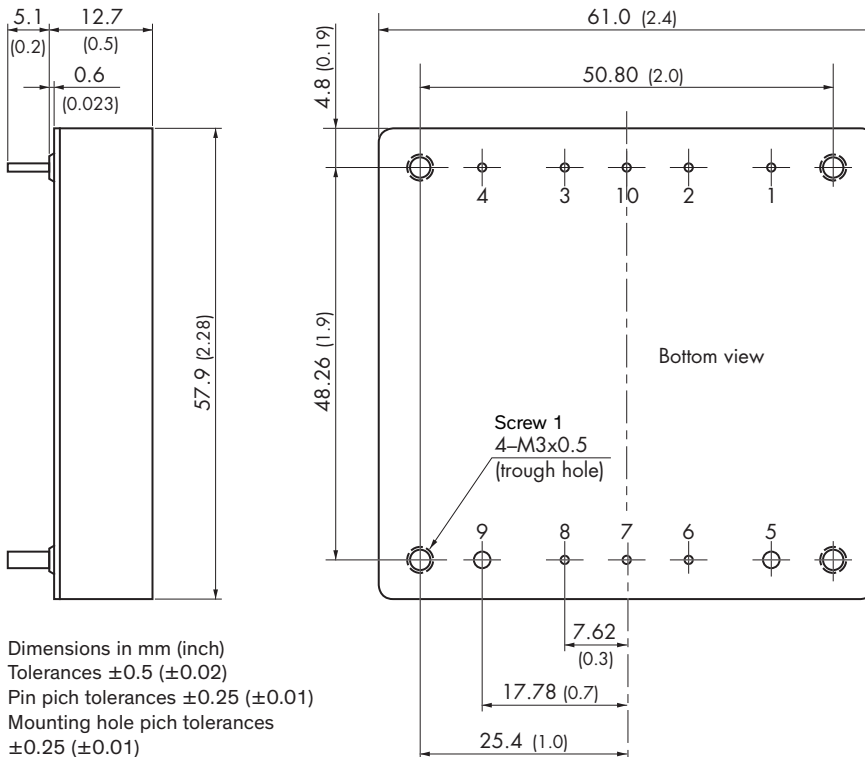

Dimensions in mm (inch)
 Tolerances ± 0.5 (± 0.02)
 Pin pitch tolerances ± 0.25 (± 0.01)
 Mounting hole pitch tolerances
 ± 0.25 (± 0.01)

Pin diameter pins 5 & 9: 2.0 (0.08)
 Pin diameter other pins: 1.0 (0.04)

Pinout	
Pin	Function
1	-Vin (GND)
2	NC
3	Remote
4	+Vin (Vcc)
5	-Vout
6	-Sense
7	Trim
8	+Sense
9	+Vout
10	Sync (on demand)

NC: No Connection

The screw 1 locked torque
 (24 and 48Vout models):
 MAX 5.0kgf-cm/0.49N-m

The screw 1 locked torque
 (110Vout models):
 MAX 3.5kgf-cm/0.34N-m