

TOSHIBA



> BLUETOOTH

SILICON AND SOFTWARE FOR
WIRELESS COMMUNICATION



ULTRA HIGH INTEGRATION

> BLUETOOTH® ICs

Ultra Long Range & Ultra Low Current

As one of the founding members and as an active promoter company of the Bluetooth Special Interest Group (SIG), Toshiba's high quality Bluetooth® ICs benefit from over 20 years experience. The Bluetooth 5 controller family offers ultra long range thanks to their leading 113dBm link budget. It is therefore ideally suited for home & building automation, automotive and smart agricultural usage. The Bluetooth 4.2 controller family minimizes power consumption to only 3.3mA in the receiver and transmitter and is thus a perfect choice for battery powered applications such as beacons and trackers.



> BLUETOOTH 5 ULTRA LONG RANGE

- Support for optional Bluetooth 5 features
- Extended temperature range up to 125°C
- Automotive qualification available
- Bluetooth Mesh 1,0 support (planned)
- Only 11 external components

> BLUETOOTH 4.2 ULTRA LOW CURRENT

- Support for optional Bluetooth 4.2 features
- Extended temperature range up to 105°C
- Automotive qualification available
- Bluetooth Mesh 1,0 support
- Only 7 external components

> DUAL MODE BLUETOOTH CLASSIC + LOW ENGERY

- Compliant to Bluetooth Low Energy 4.2
- Embedded Serial-Port-Profile (SPP)
- Embedded GATT Profile
- Ideal solution for cable replacement
- Automotive qualification available

> PRODUCT LINE-UP

TC3568x	TC3567x	TC35661
Bluetooth Low Energy 5.0	Bluetooth Low Energy 4.2	Bluetooth Classic & Low Energy 4.2
144KB Total RAM	128KB / 192KB Total RAM	None
None / 128KB Flash	None / 128KB / 256KB Flash	None
113dBm link budget (max)	93.5 dBm link budget (max)	93dBm link budget (max)
5.1mA (RX) / 6.0mA (TX)	3.3mA (RX / TX)	63 mA (RX / TX)
-40°C to +85°C / -40°C to +125°C	-40°C to +85°C / -40°C to +105°C	-40°C to +85°C
AEC-Q100 (optional)	AEC-Q100 (optional)	AEC-Q100 (optional)



> TC35661

FOR BLUETOOTH® CLASSIC (3.0+EDR) AND BLUETOOTH LE (4.0/4.2)

The TC35661 series are highly integrated RFCMOS Bluetooth devices; supporting Bluetooth Classic (3.0+EDR) and Bluetooth Low Energy (LE) 4.0 and 4.2 standards. The devices realise an easy way to integrate Bluetooth for various industrial, medical and automotive applications. Toshiba has tested the Bluetooth interoperability extensively. All Toshiba Bluetooth devices and software are Bluetooth Qualification Expert (BQE) qualified.

> KEY BENEFITS

- Dual Mode core for classic and new Bluetooth 4.0/4.2 standard
- BQE qualified hardware and software for easy Bluetooth EPL
- Flexible system architectures through:
 - HCI model
 - Embedded stack and profile model
- Embedded on-chip Bluetooth stack and selected profiles for easy Bluetooth system design
- Small footprint due to low bill of materials
- Multiple programmable IO and peripheral options
- Single voltage supply due to on-chip voltage controller and low power modes

> FEATURES

- Bluetooth Core Spec 3.0, 4.0 and 4.2 EDR and LE support
- TC35661-009: HCI type
- TC35661-XXX: embedded profile type and support for Bluetooth Low Energy GAP peripheral mode
- BT Class 2 support
- RX Sensitivity -91dBm (typ.)
- Baseband with ARM® CPU - 13 to 52 MHz
- On-chip ROM, RAM, including Patch-RAM
- On-chip balun, antenna switch, LNA, LDO
- Interfaces: UART, SPI, USB2.0(FS), I2C, I2S/PCM, GPIO
- Data transfer up to 2 Mbps (DH5 packets) net
- Package: 64ball BGA (ROM version), 0.5/0.8mm pitch, 1.2/1.4mm height
- Operational voltage: 1.8V or 3.3V (typ.)
- Low power sleep mode 30uA (max)
- Operation current well below 30mA (depends on packet type and selected operational mode)
- AEC-Q100 automotive qualification (0.8mm pitch)

SINGLE CHIP CONTROLLER

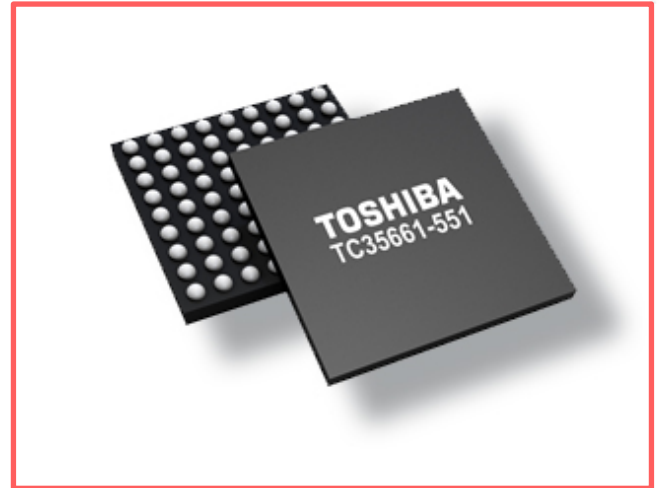

System	System Configuration	Product ID (*)
BT 4.2 HCI standard & WideBand speech	HCI	TC35661-009
BT 4.0 / 4.2 Embedded Profile	SPP (with EDR)	TC35661-203
	SPP + BLE GATT	TC35661-503
		TC35661-551

(*) Subject to firmware updates. Subject to change without notice.

> TC35661SBG (FBGA64)

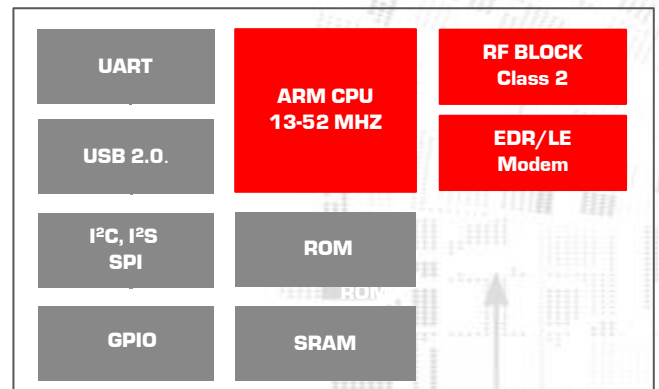

> HCI SYSTEM CONCEPT

The Bluetooth HCI (host controller interface) model: the low layer stack (RF, LC, LM) runs on the TC35661 device for both Bluetooth Classic and BLE (4.0 +4.2). Through a UART or USB it is connected to an external host processor, which executes the upper Bluetooth stack (L2CAP, RFCOMM) and profiles. Beside the upper stack the host processor runs the application software. This application processor may also run additional tasks such as middleware and multimedia functions. This concept is suitable for voice and data. It can be combined with third-party Bluetooth protocol stacks over the standardized HCI software interface.

> TC35661-00x

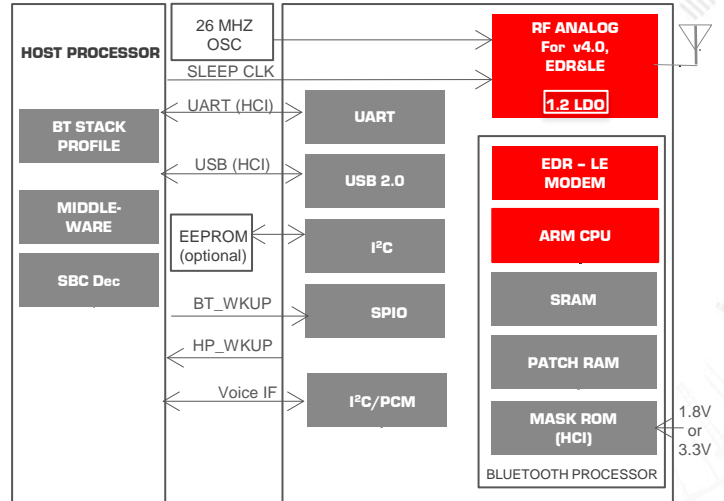

> EMBEDDED PROFILE SYSTEM CONCEPT

The embedded profile model integrates both the lower and upper stack as well as some selected profiles in the TC35661. The UART interface carries control and payload data to/from the embedded API. The entire Bluetooth functionality is managed by the Bluetooth LSI. The host processor handles the application data and some basic system control. Depending on the complexity of the application, the host CPU performance requirement is very minor. This concept is for data only. Toshiba offers source code for an optional high level host driver fitting to the embedded API in order to simplify design to enable fast time to market.

> TC35661-XXX

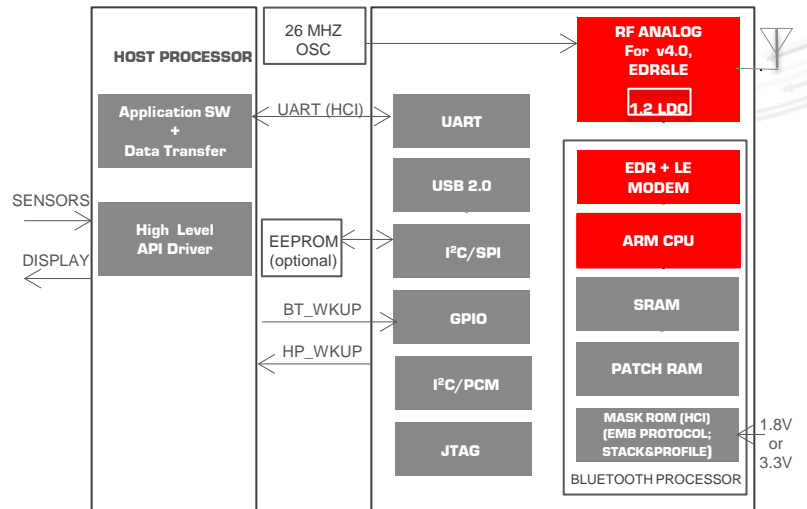

> TC35661 EMBEDDED PROFILE SOFTWARE MODELS

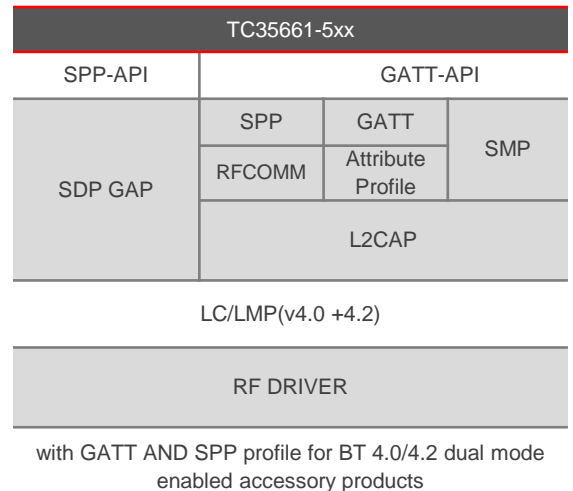
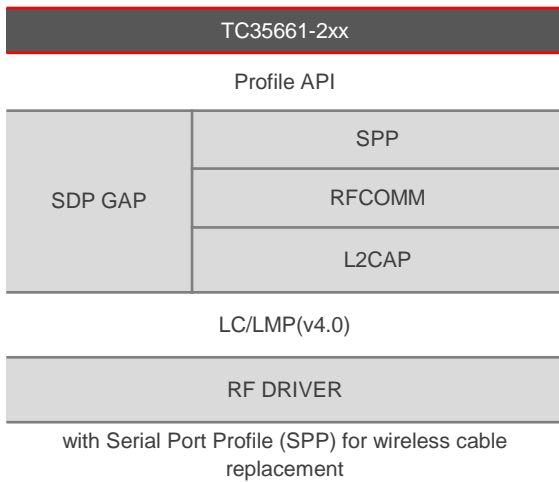

The Bluetooth® word mark and logos are registered trademarks owned by Bluetooth SIG, Inc. Arm and Cortex are registered trademarks of Arm Limited (or its subsidiaries) in the United States and/or other countries. Copyright 2018 TOSHIBA Electronic Devices & Storage Corporation. Product specifications are all subject to change without notice. Product design specifications and colours are subject to change without notice and may vary from those shown. Errors and omissions excepted.

> TC3567x FAMILY FOR BLUETOOTH® LOW ENERGY 4.2

Toshiba's TC3567x single chip Bluetooth Low Energy 4.2 SoC family offers class-leading low peak power consumption of only 3.3mA for the transmitter and receiver. This enables ultra long battery runtime, which is crucial for battery powered devices such as trackers or handheld healthcare products. Particularly if those products are disposable without battery recharging or replacement options. All optional Bluetooth Low Energy 4.2 features are supported, which is equal to the Bluetooth 5 mandatory feature set.

> HIGHLIGHTS

Ultra long battery runtime

- Ideal for disposable and battery powered devices
- Class-leading low peak power consumption of 3.3mA @0dBm (RX/TX)
- 50nA deep sleep mode
- 10 years battery runtime using a CR2032 coin cell assuming a 5 second advertising interval

Support for all Bluetooth Low Energy 4.2 features (incl. optional features)

- Low Energy Data Packet Length Extension
- Low Energy Secure Connections
- Link Layer Privacy
- Link Layer Extended Scanner Filter Policies

Extended temperature range*1

- Wide temperature range from -40°C up to 105°C

High integration

- Small PCB footprint and Bill-of-Materials (BOM) cost as only 7 external components are required
- Integrated matching circuit for 50Ω antenna
- Small 5mm x 5mm QFN40 package

Automotive*1

- AEC-Q100/Q006 qualification
- QFN40 package with wettable flank

Bluetooth mesh extension*1

- Bluetooth mesh 1.0 extension supported by the Software Development Kit (SDK)

> SOC BLOCK DIAGRAM

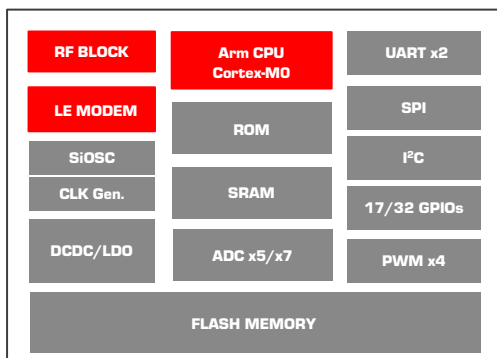

(*1) Note: Supported by certain derivatives (see table on next slide)

ULTRA LOW POWER



> FEATURES

Simultaneous connections

- Up to 2 master and 8 slave connections*1

High security

- AEC-128bit data encryption/ECDH secure connection
- True random number generation*1
- Flash content protection (by password)*1
- SWD (Single Wire Debug) can be disabled*1
- Unique 128bit chip ID (optional)

Flexible system architecture

- Standalone mode and host mode supported

High integration

- 26MHz Arm® Cortex®-M0 MCU core
- Embedded Flash Memory (up to 256KB)*1
- Integrated DCDC and LDO (1.8 to 3.6 supply voltage)
- On-chip analog: LNA, balun, antenna switch, matching circuit (for 50 Ω)

Ease of use

- Pre-certified SoC and embedded Bluetooth protocol stack (QDIDs) enable easy certification
- Convenient AT command interface
- BT SIG standard profiles and application examples included in SDK
- Toshiba plug-ins for the Bluetooth Developer Studio (BDS)

Peripherals

- 2x UART, 1x SPI, 1x I²C, PWM output (4 channels), 10bit ADC (5/7 channels), 17/32 GPIOs

> STAND ALONE SYSTEM DIAGRAM

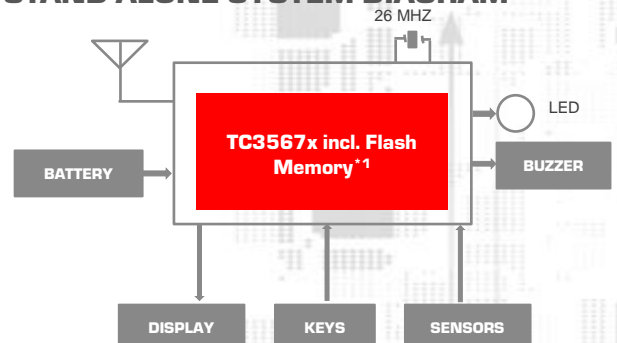

> BEST-IN-CLASS LOW CURRENT CONSUMPTION

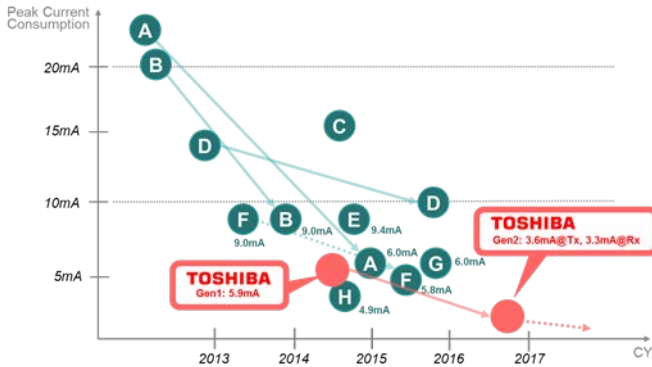

> SOFTWARE DEVELOPMENT KIT (SDK)

- Bluetooth drivers
- Simple AT commands
- BT SIG standard profile and examples
- Toshiba "SPPoverBLE" profile

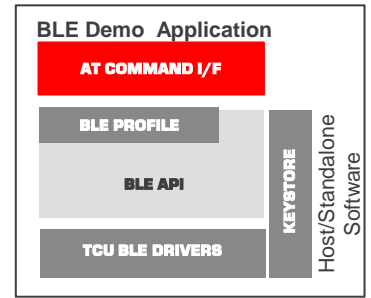

> DEVELOPMENT BOARDS AND MODULES

- Toshiba development board in USB stick form factor (Partnumber: BMSKUSBBT1760A)
- Further development boards available from Sensys
- Modules available from Panasonic (Partnumber PAN1760A)



> MESH LIGHTING REFERENCE DESIGN

- Implementation of one Bluetooth mesh lighting node
- Bluetooth mesh 1.0 compliant
- Relay functionality
- HSL lighting server mesh model
- Android reference application
- Fast time-to-market (TTM)



> BLUETOOTH LOW ENERGY 4.2 PRODUCTS

	TC35678	TC35679	TC3567C	TC3567D
Peak transmitter current @ 0dBm	3.3mA			
Peak receiver current	3.3mA			
Sleep / deep sleep current	<1.7 μ A / 50 nA			
Standalone mode support	Yes			
BLE central and peripheral support	Yes			
Mesh 1.0 support	Yes	No		
Maximum number of simultaneous connections	Maximum 8 in total (2 master and 8 slave connections)		Maximum 4 in total (2 master and 4 slave connections)	
Supported optional features	LE Data Packet Length Extension LE Secure Connections Link Layer Privacy Link Layer Extended Scanner Filter Policies			
True Random Number Generator TRNG)	No		Yes	
NVM protection by password	No	N/A	Yes	N/A
Capability to disable SWD interface	No		Yes	
NVM area available for user	256 KB	None	128 KB	None
RAM available for user application	83 KB		51 KB	
Package	QFN40 5x5mm QFN60 7x7mm	QFN40 5x5mm QFN40 6x6mm	QFN40 5x5mm	QFN40 5x5mm
Automotive Quality Grade available	No	Yes	No	
Temperature range	-40°C up to 85°C	-40°C up to 105°C	-40°C up to 85°C	
Number of external components				7



> TC3568x FAMILY

BLUETOOTH® LOW ENERGY 5

The TC3568x family offers full Bluetooth 5 compatibility and supports all optional Bluetooth 5 features required to deliver 4x range, 2x speed and 8x broadcast message capacity. The SoC has an industry leading receiver sensitivity of -105dBm at 125Kbps, and a built-in high efficiency power amplifier that delivers up to +8dBm transmission power. This leads to an ultra long communication range with low current consumption. TC35681 supports an extended operating temperature range of -40°C to +125°C. The line-up is completed with an automotive grade product.



> HIGHLIGHTS

Ultra long communication distance

- Ideal for home and building automation, automotive, smart agriculture, asset tracking, street lighting and factory automation
- Class-leading high link budget of 113dBm
- Up to 1.3Km (0.8mils) free-space communication range in ideal space^{*1}

Support for all Bluetooth Low Energy 5 features (incl. optional features)

- LE 2M PHY
- LE Coded PHY (500Kbps, 125Kbps)
- LE Advertising Extensions
- High Duty Cycle Non-Connectable Advertising
- LE Channel Selection Algorithm #2

Extended temperature range^{*2}

- Wide temperature range from -40°C up to 125°C

High integration

- Small PCB footprint and Bill-of-Materials (BOM) cost as only 11 external components are required
- QFN 5x5 mm and Chip Scale Package (CSP) available

Automotive grade^{*2}

- AEC-Q100 qualification
- QFN40 package with wettable flank

> PRODUCT LINE-UP

Product name	Flash Memory	Temperature Range	Automotive Grade	Package	Link Budget
TC35680	128KB	-40°C to 85°C	No	5x5 mm QFN40	113dBm
TC35681	None	-40°C to 125°C	Available	5x5 mm QFN40 6x6 mm QFN40 WCSP	113dBm

> FEATURES

High security

- AEC-128bit data encryption/ECDH secure connection
- True random number generator
- Flash content protection (by password)^{*2}
- SWD (Single Wire Debug) can be disabled
- Unique 128bit chip ID (optional)

Flexible system architecture

- Standalone mode and host mode supported

High integration

- 32MHz Arm® Cortex®-M0 MCU core
- Embedded Flash Memory (up to 128KB)^{*2}
- Integrated DCDC and LDO (1.9 to 3.6 supply voltage)
- On-chip analog: LNA, balun, antenna switch, matching circuit (for 50 Ω)

Ease of use

- Pre-certified SoC + embedded Bluetooth protocol stack (QDIDs) enable easy certification
- Convenient AT command interface
- BT SIG standard profiles + application examples included in SDK
- Toshiba plug-ins for the Bluetooth Developer Studio (BDS)

Peripherals

- 2x UART, 2x SPI, 2x I²C, PWM output (4 channels), 12bit ADC (5 channels), 18 GPIOs

(*1) Note: Depends on environmental factors such as Fresnel effect (i.e. antenna height)
(*2) Note: Supported by certain derivatives (see table above)



> BLUETOOTH® DEVELOPMENT TOOLS

> TOSHIBA BLUETOOTH 4.2 - USB STARTER KIT FOR TC35678FSG

Reduce Time-to-Market (TTM) and development cost with the USB-based Bluetooth development platform from Toshiba Electronics Europe GmbH. Based around the ultra low power TC35678 Bluetooth Low Energy (BLE) 4.2 single-chip controller, the Bluetooth development board provides all that is needed to efficiently develop, debug and test advanced Bluetooth Low Energy applications in a single, easy-to-use platform.

> KEY BENEFITS

- Usable for development, debugging, evaluation and prototyping
- All GPIO pins are available on headers/jumpers to connect own hardware
- Can be configured for either host or standalone mode by setting GPIO lines during a reset operation
- Sleep, back-up and deep sleep available and GPIO lines can be used for waking up the system
- The device can be used through the USB hub as a target platform within an Integrated Development Environment (IDE) (e.g. IAR® or Arm® Keil MDK)
- Toshiba software tool (EasyStandAlone) allows programming of the embedded flash memory from PC
- A Graphical User Interface (GUI) PC application allows access to the Bluetooth LSI via the on-board FTDI-UART connection for host mode applications running on the PC

> FEATURES

- USB Starter kit with PAN1760A module containing TC35678FSG Bluetooth LE controller
- USB-SWD J-link connection
- FTDI-UART connection for host system (e.g. on PC) and embedded flash programming
- Headers/jumpers for external system reset, GPIO lines and power control

> PARTNUMBER

BMSKUSBBT1760A(P)

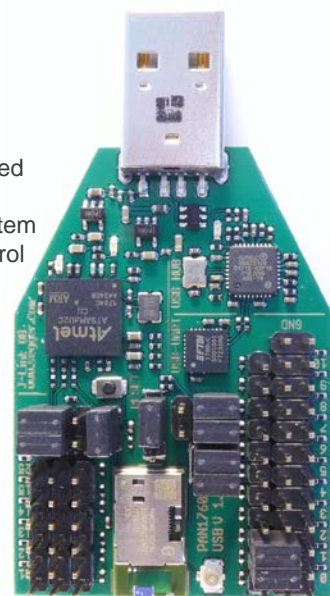

> TOSHIBA BLUETOOTH 5 - USB STARTER KIT FOR TC35680FSG

The USB starter kit for the Bluetooth 5 controller (TC35680FSG) will be available later in 2018. It will be based on the Bluetooth 4.2 USB starter kit described above and hence share the same features and benefits.

> SENSYST BLUETOOTH 4.2 - DEVELOPMENT BOARDS FOR TC3567x FAMILY

For development on other derivatives of the TC3567x Family, Sensys provides a series of development boards. The distributor for EMEA is chip1stop.com..

> FEATURES

- Approved by FCC and MIC
- Equipped with pattern antenna and RF evaluation connector
- Powered by USB Bus or external supply
- GPIOs directly accessible
- USB-UART bridge IC on-board
- 10-pin SWD connector for debugging
- CMSIS-DAP¹ on-board for Arm® Cortex®-M0 debugging

> PARTNUMBERS

SAPPHIRE-67CFSG
SAPPHIRE-67DFSG
SAPPHIRE-679FSG
SAPPHIRE-678FXG
SAPPHIRE-678FSG

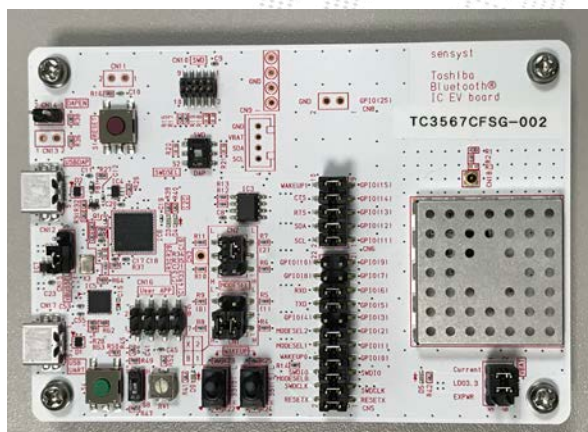

¹ Available on SAPPHIRE-67CFSG and SAPPHIRE-67DFSG

> BLUETOOTH SOFTWARE SUPPORT

Toshiba offers a Bluetooth Software Development Kit (SDK) with Bluetooth Classic and Bluetooth Low Energy (BLE) driver software source code in C-language. The SDK is a free of charge reference software for use with Toshiba Bluetooth LSIs. The software can be ported onto any external host processor (connected to the Bluetooth LSI via UART) or used for stand-alone (no external host) designs. The driver links to the embedded firmware of each supported Toshiba Bluetooth LSI.

The SDK simplifies the usage of the embedded Bluetooth stack via an abstracted high level API, thus enabling fast system integration. It is available for dual mode (classic SPP&BLE; host needed) and single mode (BLE only, with or without host) devices. It contains quick-start-guides and both embedded software application examples as well as Android™ application examples for mobile devices. Toshiba offers various compliancy tested BLE profiles as reference as well as Toshiba's original SPPoverBLE serial transmission profile. AT commands are available for all BLE designs with external host. They further simplify the programming, thus reducing the memory footprint on the host side.

Toshiba offers a plug-in for the Bluetooth SIG Developer Studio (BDS), which is a tool to develop own BLE profiles and implement them into a Toshiba Bluetooth controller. The SDK can be used with or without Real Time Operating Systems (RTOS). Toshiba offers regular updates via the Bluetooth Developer Zone website.

The Bluetooth SDK can be downloaded after registration on the online Bluetooth Developer Zone, which can be done via the following link: apps.toshiba.de/web/SDKRegistration

> KEY BENEFITS

Fast development

- Demo applications
- Huge variety of profiles
- BDS*1 support
- API + AT commands

Ease of use

- Simple API
- Full encapsulation
- Highly configurable

Low risk

- Fully tested API
- Proven in end-products
- Compliancy tested profiles
- Many users

Excellent support

- Well documented
- Online Developer Zone
- Many application examples

> FEATURES

Driver API

- GAP Central/Peripheral
- GATT Server/Client
- Security Procedures
- Encaps. Key Handling
- SPP Classic roles

BLE AT commands

- GAP Central/Peripheral
- GATT Server
- Simple to use SMP
- Integrated Serial Profile

Profiles

- Beacon
- Find Me
- Proximity
- HID over GATT (HoGP)
- Heart Rate
- Health Thermometer
- Blood Pressure
- Alert Notification (client)
- ANCS (Apple Notification Center Service)

Extensions

- Mesh and Mesh Model*3

Supported Bluetooth Devices

- TC35661-501/503/551
- TC35678/79/7C/7D
- TC35680/01*2

*1 Bluetooth SIG Developer Studio

*2 Will be supported in the upcoming SDK 4.0 in October 2018

*3 Light HSL Server model

> DUAL / SINGLE MODE SDK

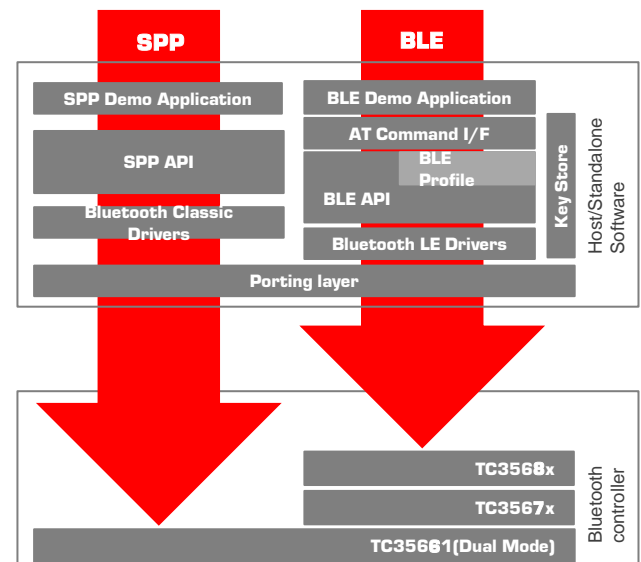

MANY-TO-MANY NETWORK

> TOSHIBA BLUETOOTH® MESH

Nowadays Bluetooth technology is available in billions of smartphones, tablets, many new cars and in thousands of different products ranging from wearables to medical devices. On a world-wide basis, 92% of all consumers are aware of the Bluetooth brand. Bluetooth mesh adds an important new dimension to the world's most widely-adopted wireless standard through its introduction of a "many-to-many" topology. By supporting the Bluetooth mesh 1.0 standard, Toshiba Bluetooth devices can interact in an interoperable, reliable, scalable and secure mesh network.



Many-to-Many topology	In addition to point to point connections (e.g., between cell phone and smart watch), multiple devices can interact with each other in a mesh network and thus unlocking new use cases.
Interoperability	A full stack solution offered by Bluetooth mesh that consists of physical layer, networking layer and application layer enables world-wide interoperability across multiple vendor devices. Immutable data models assure backward compatibility.
Reliability	Multiple, dynamic pathways from the sender to the receiver and self-healing capability leads to highly reliable network communication. Furthermore there is no bridge or router required between smartphone and mesh network which presents a single point of failure.
Scalability	Up to 30K nodes can be added to a mesh network. In practice mesh networks with over 1000 nodes are in commercial use. Messages can be relayed up to 127 times in order to travel longer distances and cover greater physical areas.
Security	As one of the latest published low power mesh standards, Bluetooth mesh offers protection against all known threats. All messages are encrypted and authenticated using AES-CCM with 128bit keys. Due to multi-layer encryption and multiple application keys, each application may use their own key and hence makes sure that e.g. a light bulb can not access messages to a door lock. When adding a new node to a mesh network, key material can be securely transferred over an unsecured channel to the new node by using Elliptic-curve Diffie–Hellman (ECDH) protocol.

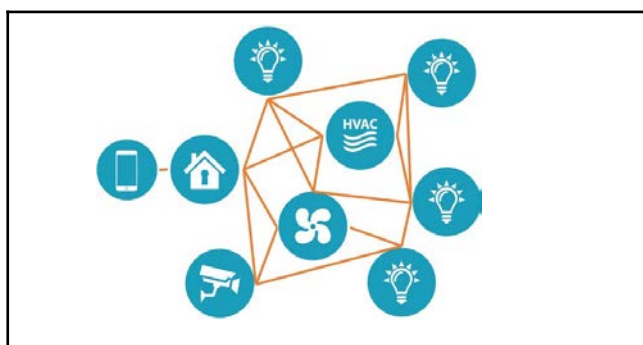

Mesh interconnected devices in a smart home network enable synergy effects e.g. by combining sensors such as light and temperature sensors with controllers for shutter, air conditioning, lighting and heating.

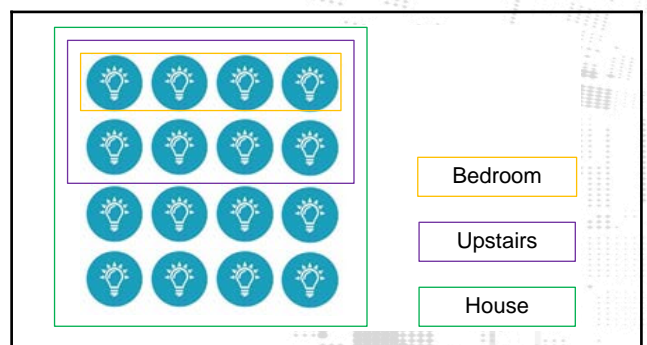

Due to the publish and subscribe paradigm, each luminaire can be subscribed to various groups. For example a luminaire may be subscribed to the groups "bedroom", "upstairs" and "house".

> TOSHIBA BLUETOOTH MESH EVALUATION PLATFORM

Control multiple boards (one board shown) via an Android™ application.

> HARDWARE

- Toshiba TC35678 Bluetooth Low Energy module
- Micro USB connection for power and UART
- USB or battery powered
- JTAG
- Multi-color LED

> QUALIFICATIONS

- Bluetooth mesh 1.0
 - Advertising bearer
 - Relay feature
- Bluetooth mesh model 1.0
 - Light HSL Server

> DELIVERABLES

- Hardware schematics
- Hardware Bill-Of-Material (BOM) list
- Bluetooth mesh firmware binary code*1
- Bluetooth mesh model sample source code
- Sample Android app
- Documentation

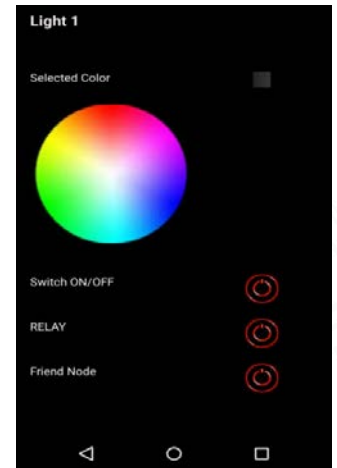

	TC35678	TC35679	TC35680	TC35681
Bluetooth version	Bluetooth Low Energy 4.2		Bluetooth Low Energy 5	
Bluetooth mesh 1.0	Qualified	Under development		
Peak current RX / TX @ 1Mbps	3.3 mA (RX) / 3.3 mA @ 0dBm (TX)		5.1 mA (RX) / 11.0 mA @ +8dBm (TX)	
Peak current RX / TX @ 2Mbps	Not available		5.5 mA (RX) / 11.5 mA @ +8dBm (TX)	
Link budget	93.5 dBm @ 1Mbps		113 dBm @ 125Kbps	
External components	7		11	
Deep sleep current	50 nA			
Internal SRAM	192 KB		144KB	
NVM storage	256 KB	None	128KB	None
Supported optional features	LE Data Packet Length Extension LE Secure Connections Link Layer Privacy Link Layer Extended Scanner Filter Policies		LE 2M PHY LE Coded PHY (500Kbps, 125Kbps) LE Advertising Extensions High Duty Cycle Non-Connectable Advertising LE Channel Selection Algorithm #2	
Temperature range	-40 °C to 85 °C	-40 °C to 105 °C	-40 °C to 85 °C	-40 °C to 125 °C
Automotive grade	No	Yes	No	Yes
Package	QFN40 / QFN60	QFN40	QFN40	QFN40 / WCSP

(*1) Note: Will be ready for mass production from March 2019

For more information please, visit toshiba.semicon-storage.com or contact your local Toshiba sales office.



REFERENCE DESIGN

> SMART PLUG

Using Bluetooth® mesh Technology

Toshiba has developed a new reference design for a smart plug using Bluetooth mesh technology. A smart plug sits in between a wall outlet and the plug of a non-smart device like a floor lamp. Toshiba's smart plug allows direct controlling of non-smart devices via Bluetooth mesh from a smartphone or tablet without the need to channel the communication via a gateway. This is a major benefit as a gateway adds to the system cost and presents a single point of failure. Furthermore global interoperability is one of the corner stones of Bluetooth mesh. Every year 3.4B interoperable Bluetooth devices are shipped and Bluetooth has a brand awareness of 92% among consumers on a world-wide basis.

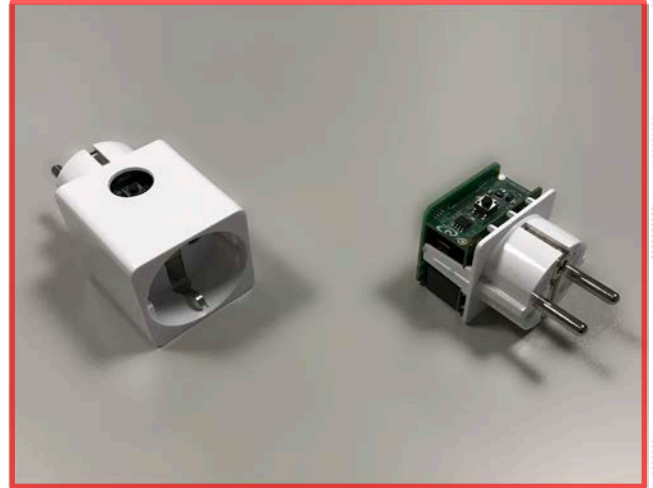

> APPLICATIONS

- Small appliances like lamps, coffee machines or fans
- Home appliances like washing machines



> FEATURES

Ready made reference design for a smart plug using Bluetooth mesh technology

Official Bluetooth mesh 1.0 technology

Embedded power measurement

Tested Bluetooth mesh stack using the "Bluetooth Profile Tuning Suite"

Highly efficient Bluetooth transmitter and receiver

Highly integrated Bluetooth LE controller

> ADVANTAGES

Design information for PCB layout, Bill-of-Material, Software, Android Application

Many-to-many network topology, self-healing, multi-layer encryption, full-stack

Measurements: Active power, Reactive power, RMS voltage, RMS current, power factor

Very high Bluetooth mesh stack quality

Industry leading 3.3mA peak power consumption of RX/TX

Only seven external components required

> BENEFITS

Development

- Reduced Time-to-Market
- Low development cost & effort
- Low development risk
- Low complexity

User Experience

- Global multi-vendor interoperability
- Industrial grade reliability
- Scalability to 1000+ nodes
- Government grade security
- Assists in optimizing power consumption in buildings

	Bluetooth LE Controller IC (TC35678)	Bluetooth LE Controller IC (TC35680) ¹
	Bluetooth Low Energy 4.2	Bluetooth Low Energy 5
Link budget	93dBm; 100dBm with external amplifier	102.5dBm @1Mbps; 113dBm @125Kbps
Current RX / TX	3.3 mA TX/RX @0dBm	11.5mA TX @+8dBm / 2Mbps; 5.5mA RX
NVM Storage	Built-in Flash 256KB	Built in Flash 128KB
Internal SRAM	192KB	144KB
Bandwidth	Up to 1Mbps	2Mbps / 1Mbps / 500Kbps / 125Kbps
Optional Features	Various BT 4.2 features implemented	Various BT 5 features implemented

¹ under development

> APPLICATION EXAMPLE SMART HOME

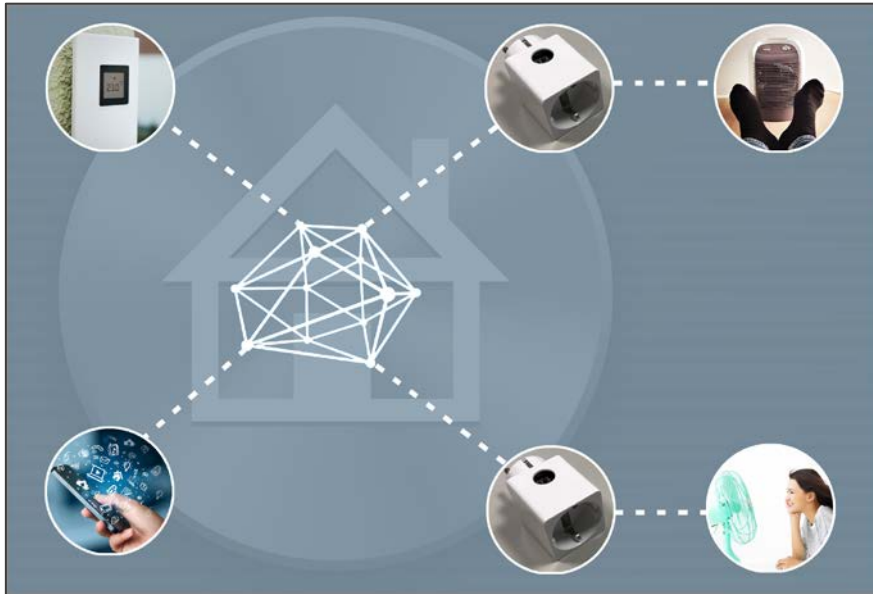

In the smart home scenario above, all nodes are connected via a Bluetooth mesh network. If the room temperature falls below a certain value, the temperature sensor can send an “on message” directly to the upper smart plug that controls a heater in order to rise the room temperature. Once the desired room temperature has been reached, the temperature sensor can send an “off message” to the upper smart plug in order to turn the heating off. The same principle is applicable to cooling. In addition to this, a user can also control the smart plugs via his mobile device and can see the measurement data of the power consumed by the attached devices.

> COMPREHENSIVE SMART PLUG SOLUTION

Bluetooth LE mesh Smart Plug Reference Design

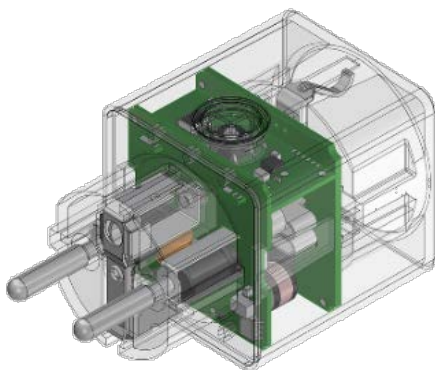

Bluetooth LE Mesh (incl. Model¹ Layer) Software Stack

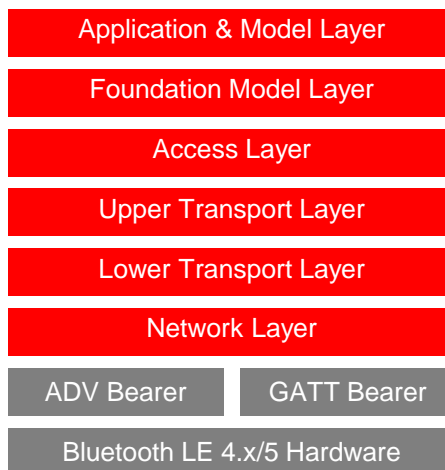

Android™ Application¹



¹ Reference software



For more information, please visit toshiba.semicon-storage.com or contact your local Toshiba sales office.

The Bluetooth® word mark and logos are registered trademarks owned by Bluetooth SIG, Inc.

Copyright 2018 TOSHIBA Electronic Devices & Storage Corporation
Product specifications are all subject to change without notice. Product design specifications and colours are subject to change without notice and may vary from those shown. Errors and omissions excepted.

201809

www.toshiba.semicon-storage.com

TOSHIBA



Toshiba Electronics Europe GmbH
Hansaallee 181
40549 Düsseldorf
Germany

Tel: +49 (0) 211 5296-0
Fax: +49 (0) 211 5296-470

**For further information on Toshiba semiconductor products and solutions
and local sales information, please visit:
www.toshiba.semicon-storage.com/eu/wireless**



The Bluetooth® word mark and logos are registered trademarks owned by Bluetooth SIG, Inc.

Copyright 2018 TOSHIBA Electronics Europe GmbH. Product specifications are all subject to change without notice.
Product design specifications and colours are subject to change without notice and may vary from those shown.
Errors and omissions excepted.