

## Power Management Unit with DCDC Controller

Check for Samples: [TPS659110](#), [TPS659112](#), [TPS659113](#)

### FEATURES

The purpose of the TPS659110 device is to provide the following resources:

- **Embedded power controller (EPC) with EEPROM programmability**
- **Two efficient step-down DCDC converters for processor cores (VDD1, VDD2)**
- **One efficient step-down DCDC converter for I/O power (VIO)**
- **One controller for external FETs (VDDCtrl)**
- **Dynamic voltage scaling for processor cores**
- **Eight LDO voltage regulators and one RTC LDO (supply for internal RTC)**
- **One high-speed I<sup>2</sup>C interface for general-purpose control commands (CTL-I<sup>2</sup>C)**
- **Two independent enable signals for controlling power resources (EN1, EN2). Alternatively, these pins can be used as a high-speed I<sup>2</sup>C interface dedicated for voltage scaling for VDD1 and VDD2.**
- **Thermal shutdown protection and hot-die detection**
- **A real-time clock (RTC) resource with:**
  - **Oscillator for 32.768-kHz crystal or 32-kHz built-in RC oscillator**
  - **Date, time and calendar**
  - **Alarm capability**
- **Nine configurable GPIOs with multiplexed feature support:**
  - **Four can be used as enable for external resources, included into power up sequence and controlled by state-machine.**
  - **As GPI, GPIOs support logic-level detection and can generate maskable interrupt for wake-up.**
  - **Two of the GPIOs have 10 mA current sink capability for driving LEDs.**
  - **DCDCs switching synchronization through an external 3-MHz clock.**
- **Two reset inputs, for cold reset (HDRST) and a**

**power initialization reset (PWRDN) for thermal reset input**

- **32-kHz clock and reset (NRESPWRON) for system and an additional output for reset signal**
- **Watchdog**
- **Two ON/OFF LED pulse generators and one PWM generator**
- **Two comparators for system control, connected to VCCS pin**
- **A JTAG<sup>®</sup> and boundary scan, but not accessible in functional mode (test purpose)**

### APPLICATIONS

- **Portable and handheld systems**

### DESCRIPTION

The TPS659110 is an integrated Power Management IC available in 98-pin 0.65-mm pitch BGA package and dedicated to applications powered by one Li-Ion or Li-Ion polymer battery cell or 3-series Ni-MH cells or a 5 V input, and which require multiple power rails. The device provides three step-down converters, one controller for external FETs to support high current rail, eight LDOs, and is designed to be flexible PMIC for supporting different processors and applications.

Two of the step-down converters provide power for dual processor cores and support dynamic voltage scaling by a dedicated I<sup>2</sup>C interface for optimum power savings. The third converter provides power for the I/Os and memory in the system.

The device includes eight general-purpose LDOs providing a wide range of voltage and current capabilities. Five of the LDOs support 1.0 to 3.3 V with 100-mV step and three (LDO1, LDO2, LDO4) support 1.0 to 3.3 V with 50-mV step. All LDOs are fully controllable by the I<sup>2</sup>C interface.

In addition to the power resources, the device contains an EPC to manage the power sequencing requirements of systems and an RTC. Power sequencing is programmable by EEPROM.

Figure 1 shows the top-level diagram of the device.



Please be aware that an important notice concerning availability, standard warranty, and use in critical applications of Texas Instruments semiconductor products and disclaimers thereto appears at the end of this data sheet.

JTAG is a registered trademark of JTAG Technologies, Inc.

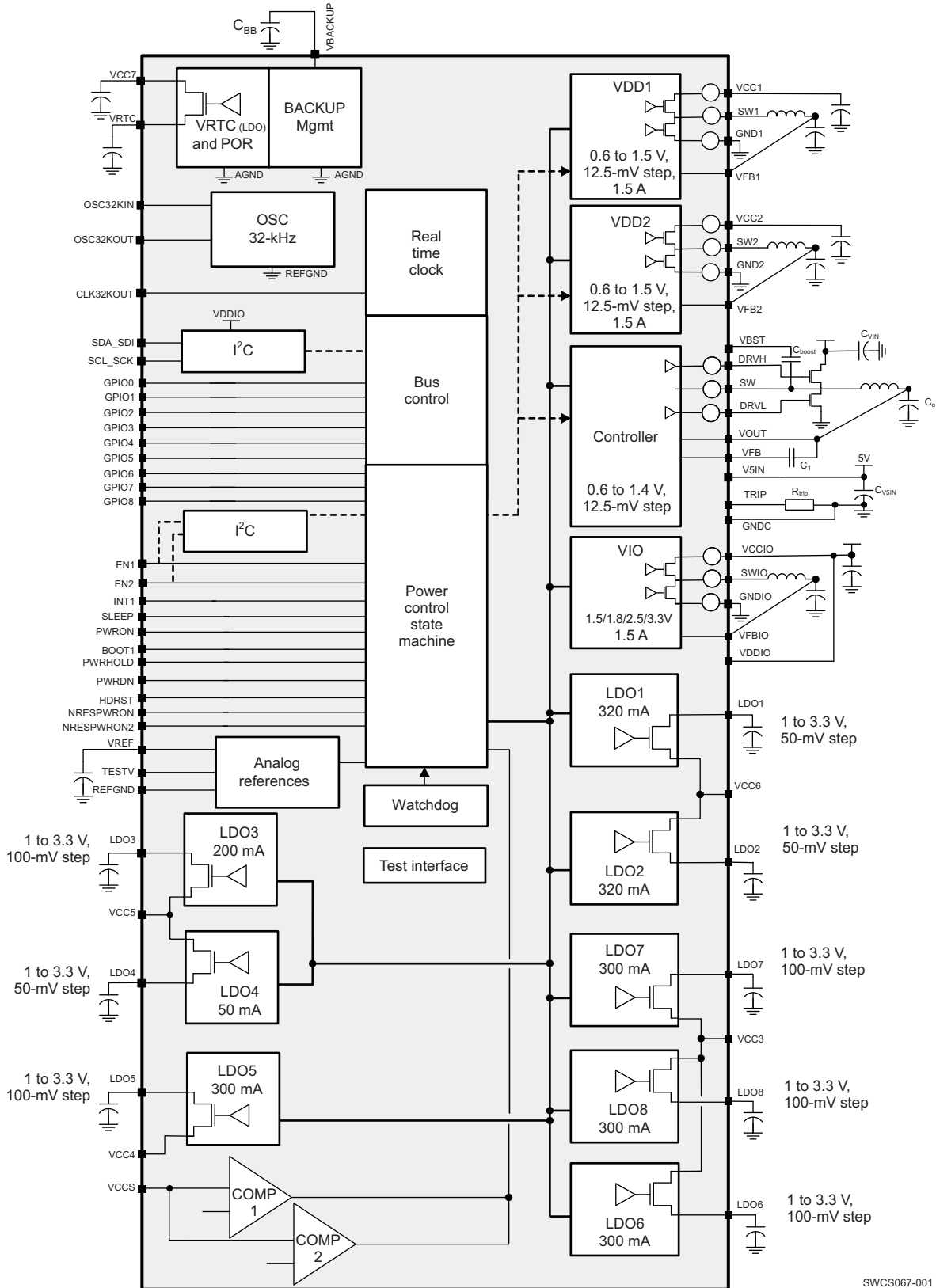

SWCS067-001

Figure 1. Top-Level Diagram

**For the complete TPS65911 data sheet, contact your TI sales representative. The document is internally available for download on ESP under the corresponding TPS659110/2/3 product folders and can be shared with customers.**

## **WARNING: EXPORT NOTICE**

**Recipient agrees to not knowingly export or re-export, directly or indirectly, any product or technical data (as defined by the U.S., EU, and other Export Administration Regulations) including software, or any controlled product restricted by other applicable national regulations, received from Disclosing party under this Agreement, or any direct product of such technology, to any destination to which such export or re-export is restricted or prohibited by U.S. or other applicable laws, without obtaining prior authorisation from U.S. Department of Commerce and other competent Government authorities to the extent required by those laws. This provision shall survive termination or expiration of this Agreement.**

**According to our best knowledge of the state and end-use of this product or technology, and in compliance with the export control regulations of dual-use goods in force in the origin and exporting countries, this technology is classified as follows:**

**US ECCN: EAR99**

**EU ECCN: EAR99**

**And may require export or re-export license for shipping it in compliance with the applicable regulations of certain countries.**

**PACKAGING INFORMATION**

Orderable Device	Status (1)	Package Type	Package Drawing	Pins	Package Qty	Eco Plan (2)	Lead/Ball Finish	MSL Peak Temp (3)	Op Temp (°C)	Device Marking (4/5)	Samples
TPS6591102A2ZRC	ACTIVE	BGA MICROSTAR JUNIOR	ZRC	98	240	Green (RoHS & no Sb/Br)	SNAGCU	Level-3-260C-168 HR	-40 to 85	TPS6591102A2	<a href="#">Samples</a>
TPS6591102A2ZRCR	ACTIVE	BGA MICROSTAR JUNIOR	ZRC	98	2500	Green (RoHS & no Sb/Br)	SNAGCU	Level-3-260C-168 HR	-40 to 85	TPS6591102A2	<a href="#">Samples</a>
TPS6591102AA2ZRC	ACTIVE	BGA MICROSTAR JUNIOR	ZRC	98	240	Green (RoHS & no Sb/Br)	SNAGCU	Level-3-260C-168 HR	-40 to 85	TPS6591102AA2	<a href="#">Samples</a>
TPS6591102AA2ZRCR	ACTIVE	BGA MICROSTAR JUNIOR	ZRC	98	2500	Green (RoHS & no Sb/Br)	SNAGCU	Level-3-260C-168 HR	-40 to 85	TPS6591102AA2	<a href="#">Samples</a>
TPS6591103A2ZRC	ACTIVE	BGA MICROSTAR JUNIOR	ZRC	98	240	Green (RoHS & no Sb/Br)	SNAGCU	Level-3-260C-168 HR	-40 to 85	TPS6591103A2	<a href="#">Samples</a>
TPS6591103A2ZRCR	ACTIVE	BGA MICROSTAR JUNIOR	ZRC	98	2500	Green (RoHS & no Sb/Br)	SNAGCU	Level-3-260C-168 HR	-40 to 85	TPS6591103A2	<a href="#">Samples</a>
TPS6591104A2ZRC	ACTIVE	BGA MICROSTAR JUNIOR	ZRC	98	240	Green (RoHS & no Sb/Br)	SNAGCU	Level-3-260C-168 HR	-40 to 85	TPS6591104A2	<a href="#">Samples</a>
TPS6591104A2ZRCR	ACTIVE	BGA MICROSTAR JUNIOR	ZRC	98	2500	Green (RoHS & no Sb/Br)	SNAGCU	Level-3-260C-168 HR	-40 to 85	TPS6591104A2	<a href="#">Samples</a>
TPS6591104DA2ZRC	ACTIVE	BGA MICROSTAR JUNIOR	ZRC	98	240	Green (RoHS & no Sb/Br)	SNAGCU	Level-3-260C-168 HR	-40 to 85	TPS6591104DA2	<a href="#">Samples</a>
TPS6591104DA2ZRCR	ACTIVE	BGA MICROSTAR JUNIOR	ZRC	98	2500	Green (RoHS & no Sb/Br)	SNAGCU	Level-3-260C-168 HR	-40 to 85	TPS6591104DA2	<a href="#">Samples</a>
TPS6591104EA2ZRC	ACTIVE	BGA MICROSTAR JUNIOR	ZRC	98	240	Green (RoHS & no Sb/Br)	SNAGCU	Level-3-260C-168 HR	-40 to 85	T6591104EA2	<a href="#">Samples</a>
TPS6591104EA2ZRCR	ACTIVE	BGA MICROSTAR JUNIOR	ZRC	98	2500	Green (RoHS & no Sb/Br)	SNAGCU	Level-3-260C-168 HR	-40 to 85	T6591104EA2	<a href="#">Samples</a>

Orderable Device	Status (1)	Package Type	Package Drawing	Pins	Package Qty	Eco Plan (2)	Lead/Ball Finish	MSL Peak Temp (3)	Op Temp (°C)	Device Marking (4/5)	Samples
TPS6591106A2ZRC	ACTIVE	BGA MICROSTAR JUNIOR	ZRC	98	240	Green (RoHS & no Sb/Br)	SNAGCU	Level-3-260C-168 HR	-40 to 85	T6591106A2	<a href="#">Samples</a>
TPS6591106A2ZRCR	ACTIVE	BGA MICROSTAR JUNIOR	ZRC	98	2500	Green (RoHS & no Sb/Br)	SNAGCU	Level-3-260C-168 HR	-40 to 85	T6591106A2	<a href="#">Samples</a>
TPS6591109A2ZRC	ACTIVE	BGA MICROSTAR JUNIOR	ZRC	98	240	Green (RoHS & no Sb/Br)	SNAGCU	Level-3-260C-168 HR	-40 to 85	TPS6591109A2	<a href="#">Samples</a>
TPS6591109A2ZRCR	ACTIVE	BGA MICROSTAR JUNIOR	ZRC	98	2500	Green (RoHS & no Sb/Br)	SNAGCU	Level-3-260C-168 HR	-40 to 85	TPS6591109A2	<a href="#">Samples</a>
TPS659110A2ZRC	ACTIVE	BGA MICROSTAR JUNIOR	ZRC	98	240	Green (RoHS & no Sb/Br)	SNAGCU	Level-3-260C-168 HR	-40 to 85	TPS659110A2	<a href="#">Samples</a>
TPS659110A2ZRCR	ACTIVE	BGA MICROSTAR JUNIOR	ZRC	98	2500	Green (RoHS & no Sb/Br)	SNAGCU	Level-3-260C-168 HR	-40 to 85	TPS659110A2	<a href="#">Samples</a>
TPS659112A2ZRC	ACTIVE	BGA MICROSTAR JUNIOR	ZRC	98	240	Green (RoHS & no Sb/Br)	SNAGCU	Level-3-260C-168 HR	-40 to 85	TPS659112A2	<a href="#">Samples</a>
TPS659112A2ZRCR	ACTIVE	BGA MICROSTAR JUNIOR	ZRC	98	2500	Green (RoHS & no Sb/Br)	SNAGCU	Level-3-260C-168 HR	-40 to 85	TPS659112A2	<a href="#">Samples</a>
TPS6591133A2ZRC	ACTIVE	BGA MICROSTAR JUNIOR	ZRC	98	240	Green (RoHS & no Sb/Br)	SNAGCU	Level-3-260C-168 HR	-40 to 85	TPS6591133A2	<a href="#">Samples</a>
TPS6591133A2ZRCR	ACTIVE	BGA MICROSTAR JUNIOR	ZRC	98	2500	Green (RoHS & no Sb/Br)	SNAGCU	Level-3-260C-168 HR	-40 to 85	TPS6591133A2	<a href="#">Samples</a>
TPS659113A2ZRC	ACTIVE	BGA MICROSTAR JUNIOR	ZRC	98	240	Green (RoHS & no Sb/Br)	SNAGCU	Level-3-260C-168 HR	-40 to 85	TPS659113A2	<a href="#">Samples</a>
TPS659113A2ZRCR	ACTIVE	BGA MICROSTAR JUNIOR	ZRC	98	2500	Green (RoHS & no Sb/Br)	SNAGCU	Level-3-260C-168 HR	-40 to 85	TPS659113A2	<a href="#">Samples</a>

(1) The marketing status values are defined as follows:

**ACTIVE:** Product device recommended for new designs.

**LIFEBUY:** TI has announced that the device will be discontinued, and a lifetime-buy period is in effect.

**NRND:** Not recommended for new designs. Device is in production to support existing customers, but TI does not recommend using this part in a new design.

**PREVIEW:** Device has been announced but is not in production. Samples may or may not be available.

**OBSOLETE:** TI has discontinued the production of the device.

<sup>(2)</sup> Eco Plan - The planned eco-friendly classification: Pb-Free (RoHS), Pb-Free (RoHS Exempt), or Green (RoHS & no Sb/Br) - please check <http://www.ti.com/productcontent> for the latest availability information and additional product content details.

**TBD:** The Pb-Free/Green conversion plan has not been defined.

**Pb-Free (RoHS):** TI's terms "Lead-Free" or "Pb-Free" mean semiconductor products that are compatible with the current RoHS requirements for all 6 substances, including the requirement that lead not exceed 0.1% by weight in homogeneous materials. Where designed to be soldered at high temperatures, TI Pb-Free products are suitable for use in specified lead-free processes.

**Pb-Free (RoHS Exempt):** This component has a RoHS exemption for either 1) lead-based flip-chip solder bumps used between the die and package, or 2) lead-based die adhesive used between the die and leadframe. The component is otherwise considered Pb-Free (RoHS compatible) as defined above.

**Green (RoHS & no Sb/Br):** TI defines "Green" to mean Pb-Free (RoHS compatible), and free of Bromine (Br) and Antimony (Sb) based flame retardants (Br or Sb do not exceed 0.1% by weight in homogeneous material)

<sup>(3)</sup> MSL, Peak Temp. -- The Moisture Sensitivity Level rating according to the JEDEC industry standard classifications, and peak solder temperature.

<sup>(4)</sup> There may be additional marking, which relates to the logo, the lot trace code information, or the environmental category on the device.

<sup>(5)</sup> Multiple Device Markings will be inside parentheses. Only one Device Marking contained in parentheses and separated by a "~" will appear on a device. If a line is indented then it is a continuation of the previous line and the two combined represent the entire Device Marking for that device.

**Important Information and Disclaimer:** The information provided on this page represents TI's knowledge and belief as of the date that it is provided. TI bases its knowledge and belief on information provided by third parties, and makes no representation or warranty as to the accuracy of such information. Efforts are underway to better integrate information from third parties. TI has taken and continues to take reasonable steps to provide representative and accurate information but may not have conducted destructive testing or chemical analysis on incoming materials and chemicals. TI and TI suppliers consider certain information to be proprietary, and thus CAS numbers and other limited information may not be available for release.

In no event shall TI's liability arising out of such information exceed the total purchase price of the TI part(s) at issue in this document sold by TI to Customer on an annual basis.

**TAPE AND REEL INFORMATION**

**QUADRANT ASSIGNMENTS FOR PIN 1 ORIENTATION IN TAPE**

\*All dimensions are nominal

Device	Package Type	Package Drawing	Pins	SPQ	Reel Diameter (mm)	Reel Width W1 (mm)	A0 (mm)	B0 (mm)	K0 (mm)	P1 (mm)	W (mm)	Pin1 Quadrant
TPS6591102A2ZRCR	BGA MICROSTAR JUNIOR	ZRC	98	2500	330.0	16.4	6.3	9.3	1.5	12.0	16.0	Q1
TPS6591104A2ZRCR	BGA MICROSTAR JUNIOR	ZRC	98	2500	330.0	16.4	6.3	9.3	1.5	12.0	16.0	Q1
TPS6591104EA2ZRCR	BGA MICROSTAR JUNIOR	ZRC	98	2500	330.0	16.4	6.3	9.3	1.5	12.0	16.0	Q1
TPS6591106A2ZRCR	BGA MICROSTAR JUNIOR	ZRC	98	2500	330.0	16.4	6.3	9.3	1.5	12.0	16.0	Q1
TPS6591109A2ZRCR	BGA MICROSTAR JUNIOR	ZRC	98	2500	330.0	16.4	6.3	9.3	1.5	12.0	16.0	Q1
TPS659110A2ZRCR	BGA MICROSTAR JUNIOR	ZRC	98	2500	330.0	16.4	6.3	9.3	1.5	12.0	16.0	Q1

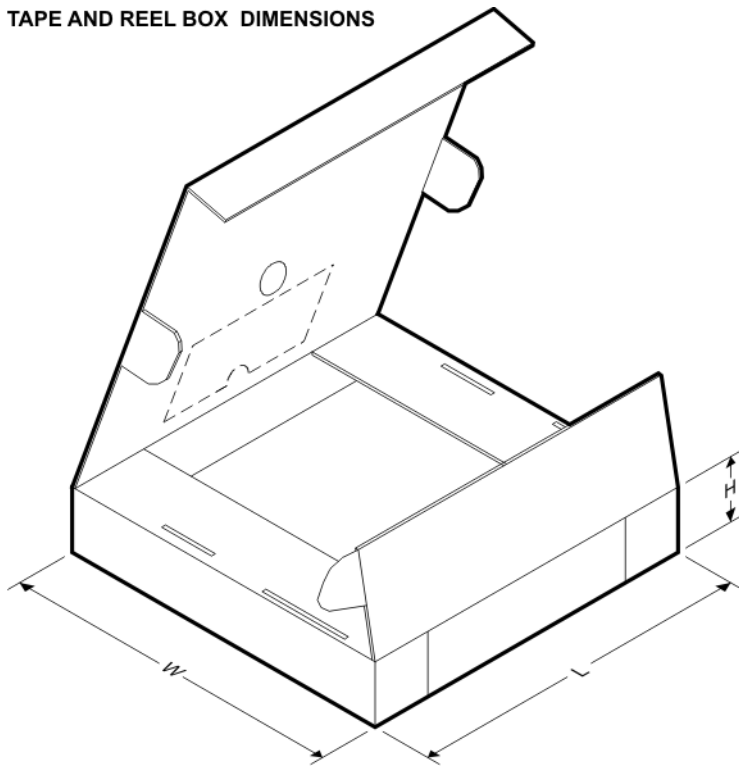

Device	Package Type	Package Drawing	Pins	SPQ	Reel Diameter (mm)	Reel Width W1 (mm)	A0 (mm)	B0 (mm)	K0 (mm)	P1 (mm)	W (mm)	Pin1 Quadrant
	OR											
TPS659112A2ZRCR	BGA MICROSTAR JUNIOR	ZRC	98	2500	330.0	16.4	6.3	9.3	1.5	12.0	16.0	Q1
TPS6591133A2ZRCR	BGA MICROSTAR JUNIOR	ZRC	98	2500	330.0	16.4	6.3	9.3	1.5	12.0	16.0	Q1
TPS659113A2ZRCR	BGA MICROSTAR JUNIOR	ZRC	98	2500	330.0	16.4	6.3	9.3	1.5	12.0	16.0	Q1

**TAPE AND REEL BOX DIMENSIONS**

\*All dimensions are nominal

Device	Package Type	Package Drawing	Pins	SPQ	Length (mm)	Width (mm)	Height (mm)
TPS6591102A2ZRCR	BGA MICROSTAR JUNIOR	ZRC	98	2500	336.6	336.6	31.8
TPS6591104A2ZRCR	BGA MICROSTAR JUNIOR	ZRC	98	2500	336.6	336.6	31.8
TPS6591104EA2ZRCR	BGA MICROSTAR JUNIOR	ZRC	98	2500	336.6	336.6	31.8
TPS6591106A2ZRCR	BGA MICROSTAR JUNIOR	ZRC	98	2500	336.6	336.6	31.8

Device	Package Type	Package Drawing	Pins	SPQ	Length (mm)	Width (mm)	Height (mm)
TPS6591109A2ZRCR	BGA MICROSTAR JUNIOR	ZRC	98	2500	336.6	336.6	31.8
TPS6591110A2ZRCR	BGA MICROSTAR JUNIOR	ZRC	98	2500	336.6	336.6	31.8
TPS659112A2ZRCR	BGA MICROSTAR JUNIOR	ZRC	98	2500	336.6	336.6	31.8
TPS6591133A2ZRCR	BGA MICROSTAR JUNIOR	ZRC	98	2500	336.6	336.6	31.8
TPS659113A2ZRCR	BGA MICROSTAR JUNIOR	ZRC	98	2500	336.6	336.6	31.8



## IMPORTANT NOTICE

Texas Instruments Incorporated and its subsidiaries (TI) reserve the right to make corrections, enhancements, improvements and other changes to its semiconductor products and services per JESD46, latest issue, and to discontinue any product or service per JESD48, latest issue. Buyers should obtain the latest relevant information before placing orders and should verify that such information is current and complete. All semiconductor products (also referred to herein as "components") are sold subject to TI's terms and conditions of sale supplied at the time of order acknowledgment.

TI warrants performance of its components to the specifications applicable at the time of sale, in accordance with the warranty in TI's terms and conditions of sale of semiconductor products. Testing and other quality control techniques are used to the extent TI deems necessary to support this warranty. Except where mandated by applicable law, testing of all parameters of each component is not necessarily performed.

TI assumes no liability for applications assistance or the design of Buyers' products. Buyers are responsible for their products and applications using TI components. To minimize the risks associated with Buyers' products and applications, Buyers should provide adequate design and operating safeguards.

TI does not warrant or represent that any license, either express or implied, is granted under any patent right, copyright, mask work right, or other intellectual property right relating to any combination, machine, or process in which TI components or services are used. Information published by TI regarding third-party products or services does not constitute a license to use such products or services or a warranty or endorsement thereof. Use of such information may require a license from a third party under the patents or other intellectual property of the third party, or a license from TI under the patents or other intellectual property of TI.

Reproduction of significant portions of TI information in TI data books or data sheets is permissible only if reproduction is without alteration and is accompanied by all associated warranties, conditions, limitations, and notices. TI is not responsible or liable for such altered documentation. Information of third parties may be subject to additional restrictions.

Resale of TI components or services with statements different from or beyond the parameters stated by TI for that component or service voids all express and any implied warranties for the associated TI component or service and is an unfair and deceptive business practice. TI is not responsible or liable for any such statements.

Buyer acknowledges and agrees that it is solely responsible for compliance with all legal, regulatory and safety-related requirements concerning its products, and any use of TI components in its applications, notwithstanding any applications-related information or support that may be provided by TI. Buyer represents and agrees that it has all the necessary expertise to create and implement safeguards which anticipate dangerous consequences of failures, monitor failures and their consequences, lessen the likelihood of failures that might cause harm and take appropriate remedial actions. Buyer will fully indemnify TI and its representatives against any damages arising out of the use of any TI components in safety-critical applications.

In some cases, TI components may be promoted specifically to facilitate safety-related applications. With such components, TI's goal is to help enable customers to design and create their own end-product solutions that meet applicable functional safety standards and requirements. Nonetheless, such components are subject to these terms.

No TI components are authorized for use in FDA Class III (or similar life-critical medical equipment) unless authorized officers of the parties have executed a special agreement specifically governing such use.

Only those TI components which TI has specifically designated as military grade or "enhanced plastic" are designed and intended for use in military/aerospace applications or environments. Buyer acknowledges and agrees that any military or aerospace use of TI components which have **not** been so designated is solely at the Buyer's risk, and that Buyer is solely responsible for compliance with all legal and regulatory requirements in connection with such use.

TI has specifically designated certain components as meeting ISO/TS16949 requirements, mainly for automotive use. In any case of use of non-designated products, TI will not be responsible for any failure to meet ISO/TS16949.

### Products

Audio	<a href="http://www.ti.com/audio">www.ti.com/audio</a>
Amplifiers	<a href="http://amplifier.ti.com">amplifier.ti.com</a>
Data Converters	<a href="http://dataconverter.ti.com">dataconverter.ti.com</a>
DLP® Products	<a href="http://www.dlp.com">www.dlp.com</a>
DSP	<a href="http://dsp.ti.com">dsp.ti.com</a>
Clocks and Timers	<a href="http://www.ti.com/clocks">www.ti.com/clocks</a>
Interface	<a href="http://interface.ti.com">interface.ti.com</a>
Logic	<a href="http://logic.ti.com">logic.ti.com</a>
Power Mgmt	<a href="http://power.ti.com">power.ti.com</a>
Microcontrollers	<a href="http://microcontroller.ti.com">microcontroller.ti.com</a>
RFID	<a href="http://www.ti-rfid.com">www.ti-rfid.com</a>
OMAP Applications Processors	<a href="http://www.ti.com/omap">www.ti.com/omap</a>
Wireless Connectivity	<a href="http://www.ti.com/wirelessconnectivity">www.ti.com/wirelessconnectivity</a>

### Applications

Automotive and Transportation	<a href="http://www.ti.com/automotive">www.ti.com/automotive</a>
Communications and Telecom	<a href="http://www.ti.com/communications">www.ti.com/communications</a>
Computers and Peripherals	<a href="http://www.ti.com/computers">www.ti.com/computers</a>
Consumer Electronics	<a href="http://www.ti.com/consumer-apps">www.ti.com/consumer-apps</a>
Energy and Lighting	<a href="http://www.ti.com/energy">www.ti.com/energy</a>
Industrial	<a href="http://www.ti.com/industrial">www.ti.com/industrial</a>
Medical	<a href="http://www.ti.com/medical">www.ti.com/medical</a>
Security	<a href="http://www.ti.com/security">www.ti.com/security</a>
Space, Avionics and Defense	<a href="http://www.ti.com/space-avionics-defense">www.ti.com/space-avionics-defense</a>
Video and Imaging	<a href="http://www.ti.com/video">www.ti.com/video</a>

### TI E2E Community

[e2e.ti.com](http://e2e.ti.com)