

16-BIT, 500-KSPS, SERIAL INTERFACE MICROPOWER, MINIATURE, SAR ANALOG-TO-DIGITAL CONVERTER

FEATURES

- 500-kHz Sample Rate
- 16-Bit Resolution
- Zero Latency at Full Speed
- Unipolar, Single-Ended Input, Range: 0 V to V_{ref}
- SPI Compatible Serial Interface with Daisy Chain Option
- Excellent Performance:
 - 93.6 dB SNR Typ at 10-kHz I/P
 - –106 dB THD Typ at 10-kHz I/P
 - ± 1.5 LSB Max INL
 - ± 1.0 LSB Max DNL
- Low Power Dissipation: 18 mW Typ at 500 KSPS
- Power Scales Linearly with Speed: 3.6 mW/100 KSPS
- Power Dissipation During Power-Down State: 0.25 μ W Typ
- 10-Pin MSOP and SON Packages

APPLICATIONS

- Battery Powered Equipments
- Data Acquisition Systems
- Instrumentation and Process Control
- Medical Electronics
- Optical Networking

DESCRIPTION

The ADS8319 is a 16-bit, 500-KSPS analog-to-digital converter. It operates with a 2.25-V to 5.5-V external reference. The device includes a capacitor based, SAR A/D converter with inherent sample and hold.

The device includes a 50-MHz SPI compatible serial interface. The interface is designed to support daisy chaining or cascading of multiple devices. Also a *Busy Indicator* makes it easy to synchronize with the digital host.

The ADS8319 unipolar single-ended input range supports an input swing of 0 V to $+V_{ref}$.

Device operation is optimized for very low power operation, and the power consumption directly scales with speed. This feature makes it attractive for lower speed applications.

It is available in 10-pin MSOP and SON packages.

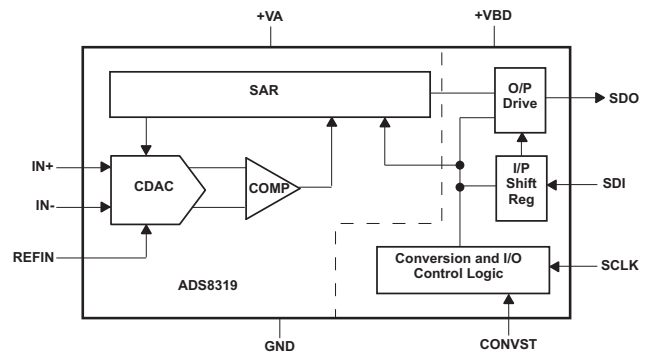

Please be aware that an important notice concerning availability, standard warranty, and use in critical applications of Texas Instruments semiconductor products and disclaimers thereto appears at the end of this data sheet.



These devices have limited built-in ESD protection. The leads should be shorted together or the device placed in conductive foam during storage or handling to prevent electrostatic damage to the MOS gates.

ORDERING INFORMATION⁽¹⁾

DEVICE	MAXIMUM INTEGRAL LINEARITY (LSB)	MAXIMUM DIFFERENTIAL LINEARITY (LSB)	NO MISSING CODES AT RESOLUTION (BIT)	PACKAGE TYPE	PACKAGE DESIGNATOR	TEMPERATURE RANGE	PACKAGE MARKING	ORDERING INFORMATION	TRANSPORT MEDIA QUANTITY
ADS8319I	±2.5	+1.5/-1	16	10 Pin MSOP	DGS	-40°C to 85°C	CBC	ADS8319IDGST	250
								ADS8319IDGSR	2500
				10 Pin SON	DRC		CBE	ADS8319IDRCT	250
								ADS8319IDRCR	2500
ADS8319IB	±1.5	±1.0	16	10 Pin MSOP	DGS	-40°C to 85°C	CBC	ADS8319IBDGST	250
								ADS8319IBDGSR	2500
				10 Pin SON	DRC		CBE	ADS8319IBDRCT	250
								ADS8319IBDRCR	2500

(1) For the most current specifications and ordering information, see the Package Option Addendum at the end of this document, or see the TI website at www.ti.com.

ABSOLUTE MAXIMUM RATINGS

over operating free-air temperature range unless otherwise noted⁽¹⁾

	VALUE	UNIT
+IN	-0.3 to +VA + 0.3	V
	±130	mA
-IN	-0.3 to 0.3	V
	±130	mA
+VA to AGND	-0.3 to 7	V
+VBD to BDGND	-0.3 to 7	V
Digital input voltage to GND	-0.3 to +VBD + 0.3	V
Digital output to GND	-0.3 to +VBD + 0.3	V
T _A Operating free-air temperature range	-40 to 85	°C
T _{stg} Storage temperature range	-65 to 150	°C
Junction temperature (T _J max)	150	°C
MSOP package	Power dissipation	(T _J Max - T _A)/θ _{JA}
	θ _{JA} thermal impedance	180
Maximum MSOP reflow temperature	ADS8319 is rated to MSL2 260C per the JSTD-020 specification	
SON package	Power dissipation	(T _J Max - T _A)/θ _{JA}
	θ _{JA} thermal impedance	70
Maximum SON Reflow Temperature	ADS8319 is rated to MSL2 260C per the JSTD-020 specification	

(1) Stresses beyond those listed under *absolute maximum ratings* may cause permanent damage to the device. These are stress ratings only, and functional operation of the device at these or any other conditions beyond those indicated under *recommended operating conditions* is not implied. Exposure to absolute-maximum-rated conditions for extended periods may affect device reliability.

SPECIFICATIONS

$T_A = -40^\circ\text{C}$ to 85°C , $+V_A = 5\text{ V}$, $+V_{BD} = 5\text{ V}$ to 2.375 V , $V_{ref} = 4\text{ V}$, $f_{SAMPLE} = 500\text{ kHz}$ (unless otherwise noted)

PARAMETER		TEST CONDITIONS	MIN	TYP	MAX	UNIT
ANALOG INPUT						
Full-scale input span ⁽¹⁾		+IN – (–IN)	0		V_{ref}	V
Operating input range		+IN	–0.1		$V_{ref} + 0.1$	
		–IN	–0.1		0.1	
Input capacitance				59		pF
Input leakage current		During acquisition		1000		pA
SYSTEM PERFORMANCE						
Resolution				16		Bits
No missing codes			16			Bits
INL	Integral linearity ⁽²⁾	ADS8319I	–2.5	± 1.2	2.5	LSB ⁽³⁾
		ADS8319IB	–1.5	± 1	1.5	
DNL	Differential linearity	ADS8319I	–1	± 0.65	1.5	LSB ⁽³⁾
		ADS8319IB	–1	± 0.5	1	
E_O Offset error ⁽⁴⁾			–1.5	± 0.3	1.5	mV
E_G Gain error			–0.03	± 0.0045	0.03	%FSR
CMRR	Common-mode rejection ratio	With common mode input signal = 200 mV _{p-p} at 500 kHz		78		dB
PSRR	Power supply rejection ratio	At FFF0h output code		80		dB
Transition noise				0.5		LSB
SAMPLING DYNAMICS						
t_{CONV}	Conversion time	+VBD = 5 V			1400	ns
		+VBD = 3 V			1400	
Acquisition time		+VBD = 5 V	600			ns
		+VBD = 3 V	600			
Maximum throughput rate with or without latency					0.5	MHz
Aperture delay				2.5		ns
Aperture jitter, RMS				6		ps
Step response				600		ns
Overvoltage recovery		Settling to 16-bit accuracy		600		ns

(1) Ideal input span, does not include gain or offset error.

(2) This is endpoint INL, not best fit.

(3) LSB means least significant bit

(4) Measured relative to actual measured reference.

SPECIFICATIONS (continued)

$T_A = -40^{\circ}\text{C}$ to 85°C , $+VA = 5\text{ V}$, $+VBD = 5\text{ V}$ to 2.375 V , $V_{ref} = 4\text{ V}$, $f_{SAMPLE} = 500\text{ kHz}$ (unless otherwise noted)

PARAMETER		TEST CONDITIONS	MIN	TYP	MAX	UNIT	
DYNAMIC CHARACTERISTICS							
THD	Total harmonic distortion ⁽⁵⁾	V_{IN} 0.4 dB below FS at 1 kHz, $V_{ref} = 5\text{ V}$		-111		dB	
		V_{IN} 0.4 dB below FS at 10 kHz, $V_{ref} = 5\text{ V}$		-106			
		V_{IN} 0.4 dB below FS at 100 kHz, $V_{ref} = 5\text{ V}$		-89			
SNR	Signal-to-noise ratio	ADS8319IB		92		dB	
		V_{IN} 0.4 dB below FS at 1 kHz, $V_{ref} = 5\text{ V}$					93.9
		V_{IN} 0.4 dB below FS at 10 kHz, $V_{ref} = 5\text{ V}$					93.6
		V_{IN} 0.4 dB below FS at 100 kHz, $V_{ref} = 5\text{ V}$					92.2
SINAD	Signal-to-noise + distortion	V_{IN} 0.4 dB below FS at 1 kHz, $V_{ref} = 5\text{ V}$		93.8		dB	
		V_{IN} 0.4 dB below FS at 10 kHz, $V_{ref} = 5\text{ V}$		93.4			
		V_{IN} 0.4 dB below FS at 100 kHz, $V_{ref} = 5\text{ V}$		87.4			
SFDR	Spurious free dynamic range	V_{IN} 0.4 dB below FS at 1 kHz, $V_{ref} = 5\text{ V}$		113		dB	
		V_{IN} 0.4 dB below FS at 10 kHz, $V_{ref} = 5\text{ V}$		107			
		V_{IN} 0.4 dB below FS at 100 kHz, $V_{ref} = 5\text{ V}$		90			
-3dB Small signal bandwidth				15		MHz	
EXTERNAL REFERENCE INPUT							
V_{ref}	Input range		2.25	4.096	VDD+0.1	V	
	Reference input current ⁽⁶⁾	During conversion		250		μA	
POWER SUPPLY REQUIREMENTS							
Power supply voltage	+VBD		2.375	3.3	5.5	V	
	+VA		4.5	5	5.5	V	
Supply current	+VA	500-kHz Sample rate		3.6	4.5	mA	
P_{VA}	Power dissipation	+VA = 5 V, 500-kHz Sample rate		18	22.5	mW	
$I_{VA_{pd}}$	Device power-down current ⁽⁷⁾	+VA = 5 V		50	300	nA	
LOGIC FAMILY CMOS							
V_{IH}	Logic level	$I_{IH} = 5\ \mu\text{A}$	$+(0.7 \times V_{BD})$		$+V_{BD}+0.3$	V	
V_{IL}		$I_{IL} = 5\ \mu\text{A}$	-0.3		$+(0.3 \times V_{BD})$	V	
V_{OH}		$I_{OH} = 2\text{ TTL loads}$	$+V_{BD}-0.3$		$+V_{BD}$	V	
V_{OL}		$I_{OL} = 2\text{ TTL loads}$	0		0.4	V	
TEMPERATURE RANGE							
T_A	Operating free-air temperature		-40		85	$^{\circ}\text{C}$	

(5) Calculated on the first nine harmonics of the input frequency

(6) Can vary $\pm 20\%$

(7) Device automatically enters power-down state at the end of every conversion, and continues to be in power-down state as long as it is in acquisition phase.

TIMING REQUIREMENTS

All specifications typical at -40°C to 85°C , $+V_A = 5\text{ V}$, $+V_{BD} \geq 4.5\text{ V}$

PARAMETER		REF FIGURE	MIN	TYP	MAX	UNIT
SAMPLING AND CONVERSION RELATED						
t_{acq}	Acquisition time	Figure 46, Figure 48, Figure 50, Figure 52	600			ns
t_{cnv}	Conversion time				1400	ns
t_{cyc}	Time between conversions		2000			ns
t_1	Pulse duration, CONVST high	Figure 46, Figure 48	10			ns
t_6	Pulse duration, CONVST low	Figure 50, Figure 52, Figure 54	20			ns
I/O RELATED						
t_{clk}	SCLK Period	Figure 46, Figure 48, Figure 50, Figure 52, Figure 54, Figure 56	20			ns
t_{ckl}	SCLK Low time		9			ns
t_{clkh}	SCLK High time		9			ns
t_2	SCLK Falling edge to data remains valid		5			ns
t_3	SCLK Falling edge to next data valid delay				16	ns
t_{en}	Enable time, CONVST or SDI Low to MSB valid	Figure 46, Figure 50			15	ns
t_{dis}	Disable time, CONVST or SDI high or last SCLK falling edge to SDO 3-state (CS mode)	Figure 46, Figure 48, Figure 50, Figure 52			12	ns
t_4	Setup time, SDI valid to CONVST rising edge	Figure 50, Figure 52	5			ns
t_5	Hold time, SDI valid from CONVST rising edge		5			ns
t_7	Setup time, SCLK valid to CONVST rising edge	Figure 54	5			ns
t_8	Hold time, SCLK valid from CONVST rising edge		5			ns

TIMING REQUIREMENTS

All specifications typical at -40°C to 85°C , $+V_A = 5\text{ V}$, $+4.5\text{ V} > +V_{BD} \geq 2.375\text{ V}$

PARAMETER		REF FIGURE	MIN	TYP	MAX	UNIT
SAMPLING AND CONVERSION RELATED						
t_{acq}	Acquisition time	Figure 46, Figure 48, Figure 50, Figure 52	600			ns
t_{cnv}	Conversion time				1400	ns
t_{cyc}	Time between conversions		2000			ns
t_1	Pulse width CONVST high	Figure 46, Figure 48	10			ns
t_6	Pulse width CONVST low	Figure 50, Figure 52, Figure 54	20			ns
I/O RELATED						
t_{clk}	SCLK period	Figure 46, Figure 48, Figure 50, Figure 52, Figure 54, Figure 56	30			ns
t_{ckl}	SCLK low time		13			ns
t_{cklh}	SCLK high time		13			ns
t_2	SCLK falling edge to data remains valid		5			ns
t_3	SCLK falling edge to next data valid delay				24	ns
t_{en}	CONVST or SDI low to MSB valid	Figure 46, Figure 50			22	ns
t_{dis}	CONVST or SDI high or last SCLK falling edge to SDO 3-state (\overline{CS} mode)	Figure 46, Figure 48, Figure 50, Figure 52			15	ns
t_4	SDI valid setup time to CONVST rising edge	Figure 50, Figure 52	5			ns
t_5	SDI valid hold time from CONVST rising edge		5			ns
t_7	SCLK valid setup time to CONVST rising edge	Figure 54	5			ns
t_8	SCLK valid hold time from CONVST rising edge		5			ns

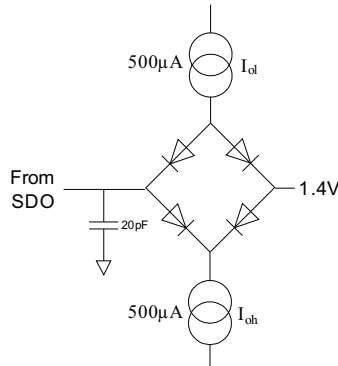

Figure 1. Load Circuit for Digital Interface Timing

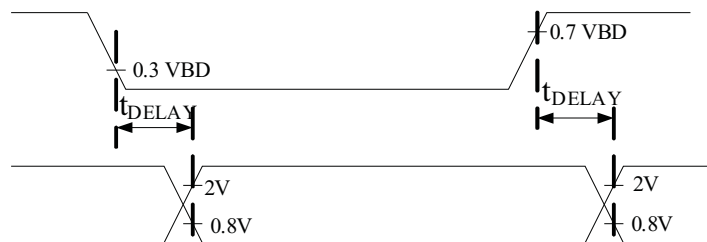
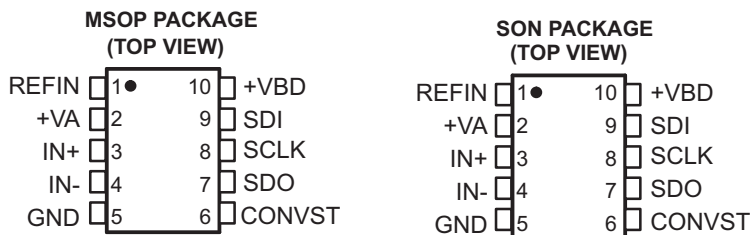

Figure 2. Voltage Levels for Timing

PIN ASSIGNMENTS



Terminal Functions

TERMINAL		I/O	DESCRIPTION
NO.	NAME		
ANALOG PINS			
1	REFIN	I	Reference (positive) input. Decouple with GND pin using 0.1- μ F bypass capacitor and 10- μ F storage capacitor.
3	+IN	I	Noninverting analog signal input
4	-IN	I	Inverting analog signal input. Note this input has a limited range of ± 0.1 V, and typically it is grounded at the input decoupling capacitor.
I/O PINS			
6	CONVST	I	Convert input. It also functions as the \overline{CS} input in 3-wire interface mode. Refer to Description and Timing Diagrams sections for more details.
7	SDO	O	Serial data output.
8	SCLK	I	Serial I/O clock input. Data (on SDO o/p) is synchronized with this clock.
9	SDI	I	Serial data input. The SDI level at the start of a conversion selects the mode of operation such as \overline{CS} or daisy chain mode. It also serves as the \overline{CS} input in 4-wire interface mode. Refer to Description and Timing Diagrams sections for more details.
POWER SUPPLY PINS			
2	+VA	-	Analog power supply. Decoupled with GND pin.
5	GND	-	Device ground. Note this is a common ground pin for both analog power supply (+VA) and digital I/O supply (+VBD).
10	+VBD	-	Digital I/O power supply. Decouple with GND pin.

TYPICAL CHARACTERISTICS

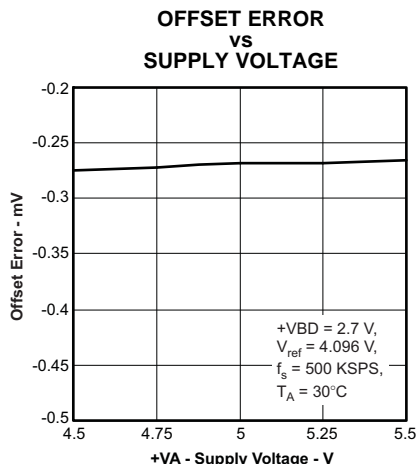

Figure 3.

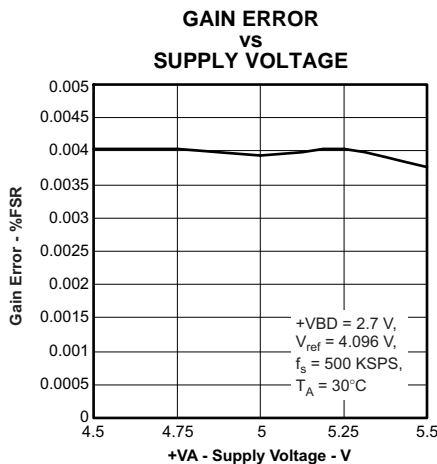

Figure 4.

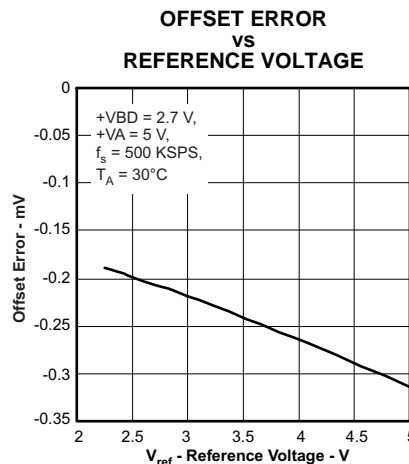

Figure 5.

TYPICAL CHARACTERISTICS (continued)

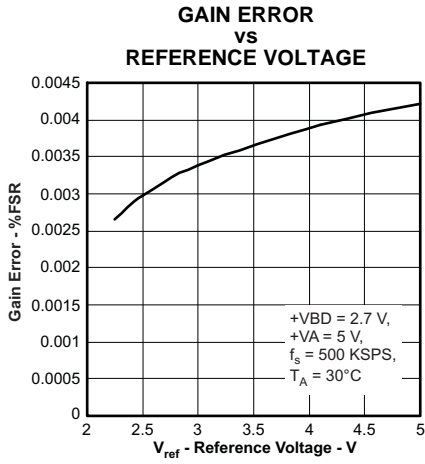

Figure 6.

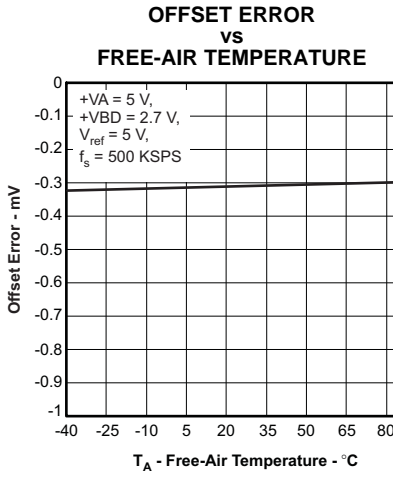

Figure 7.

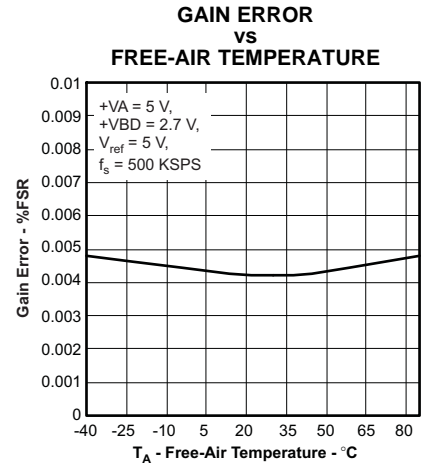

Figure 8.

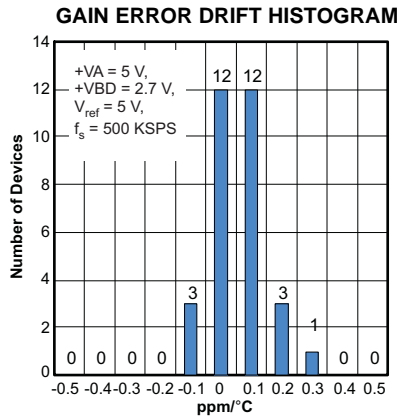

Figure 9.

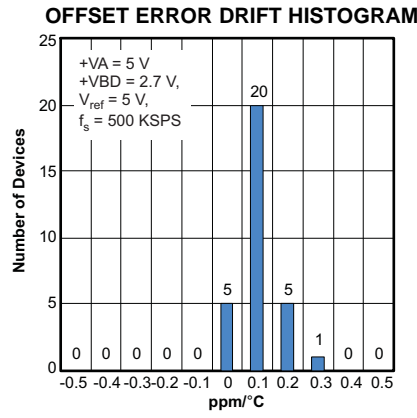

Figure 10.

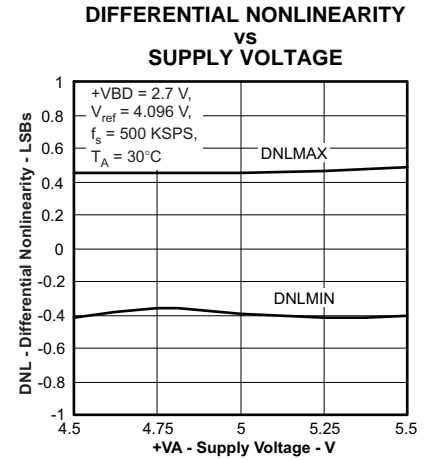

Figure 11.

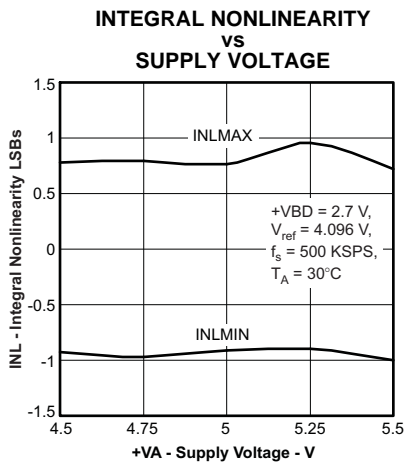

Figure 12.

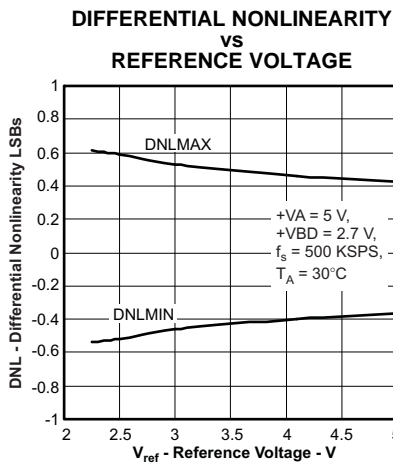

Figure 13.

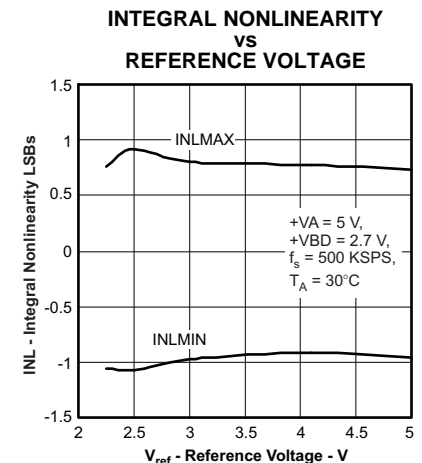

Figure 14.

TYPICAL CHARACTERISTICS (continued)

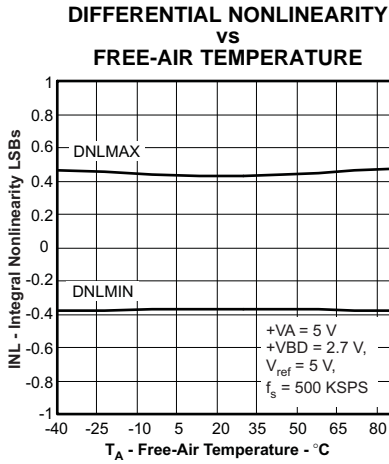

Figure 15.

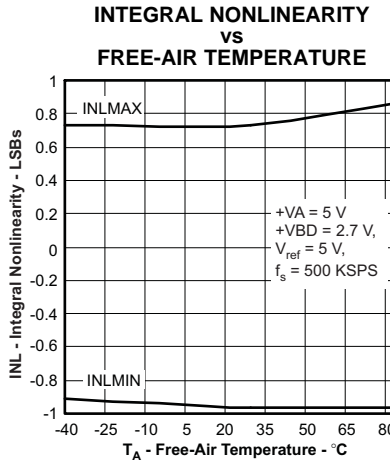

Figure 16.

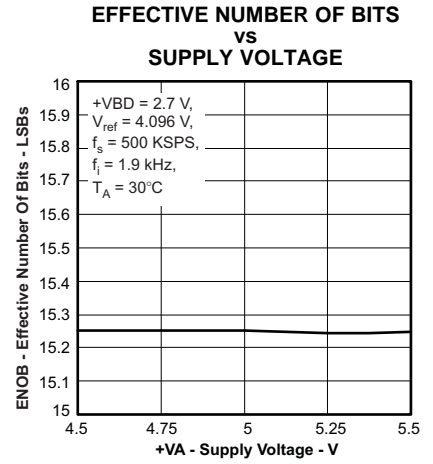

Figure 17.

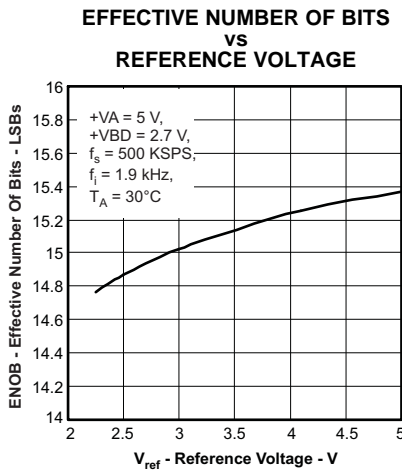

Figure 18.

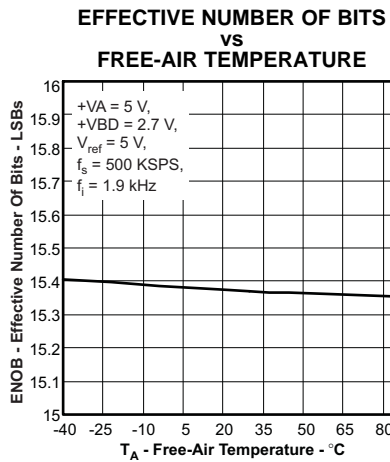

Figure 19.

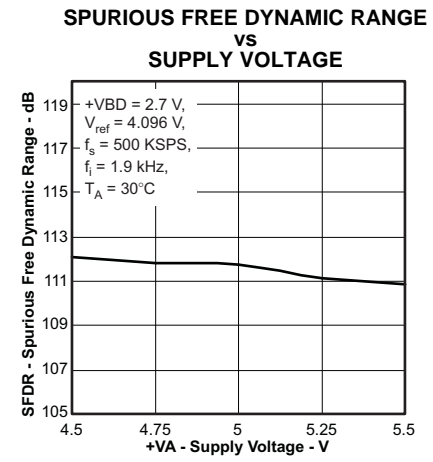

Figure 20.

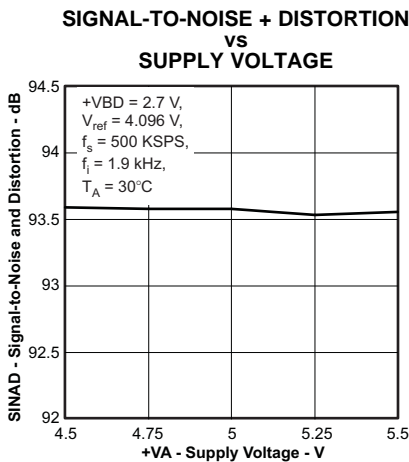

Figure 21.

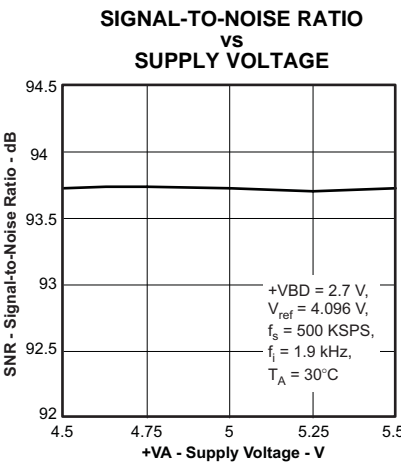

Figure 22.

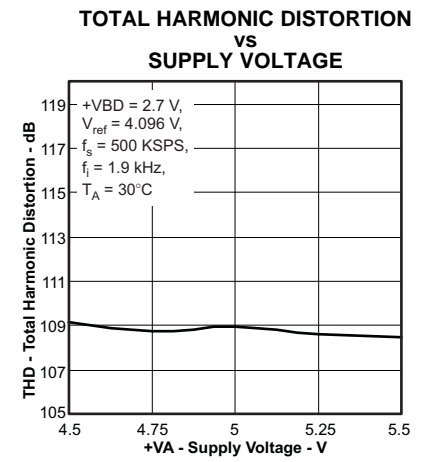

Figure 23.

TYPICAL CHARACTERISTICS (continued)

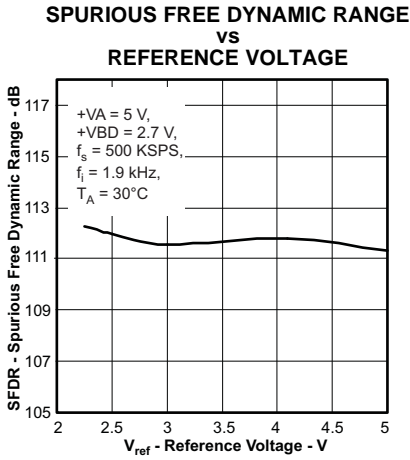

Figure 24.

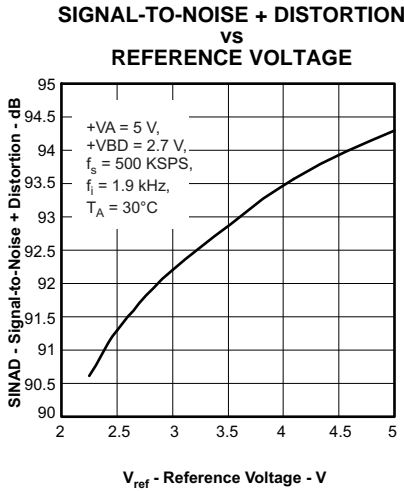

Figure 25.

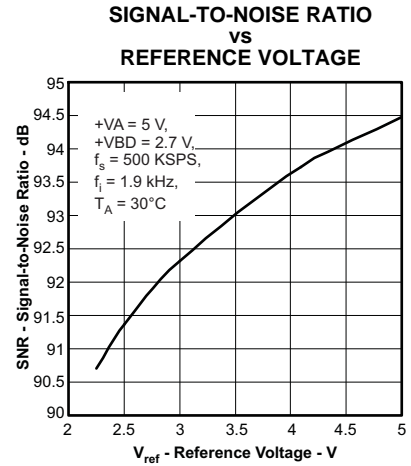

Figure 26.

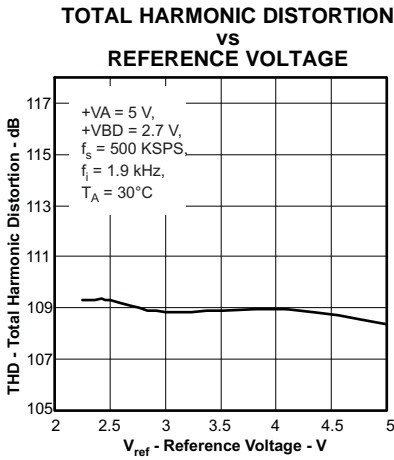

Figure 27.

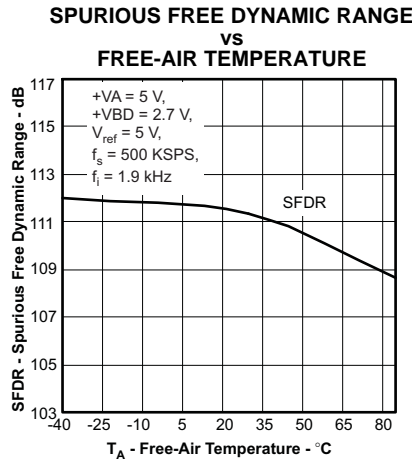

Figure 28.

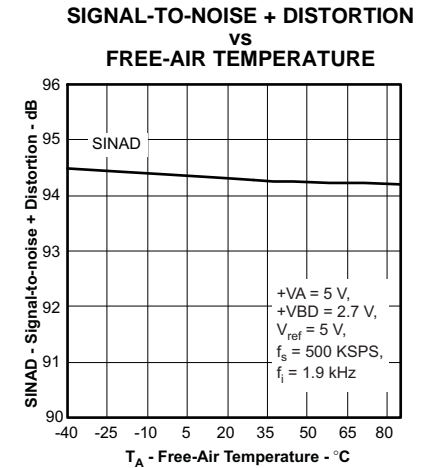

Figure 29.

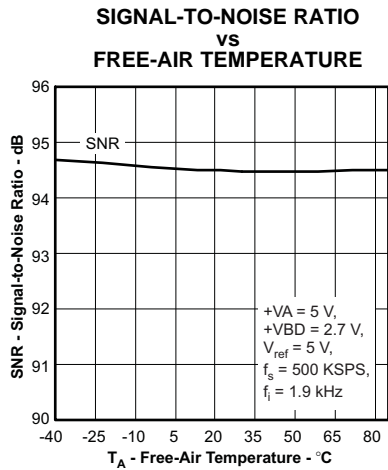

Figure 30.

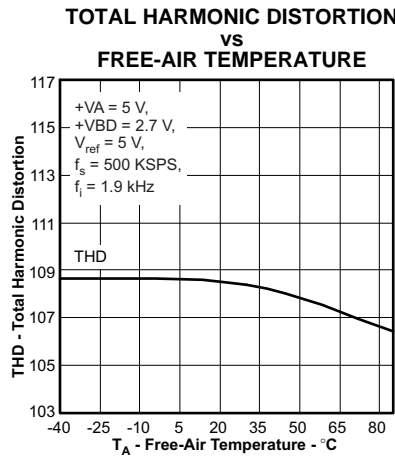

Figure 31.

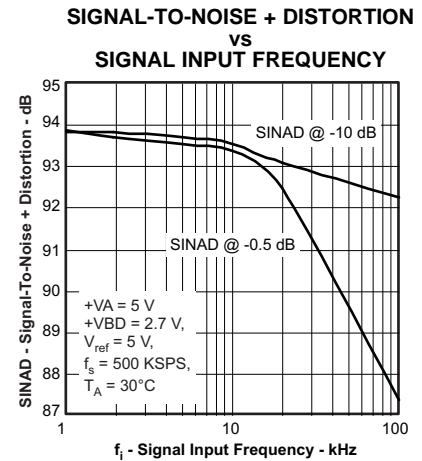

Figure 32.

TYPICAL CHARACTERISTICS (continued)

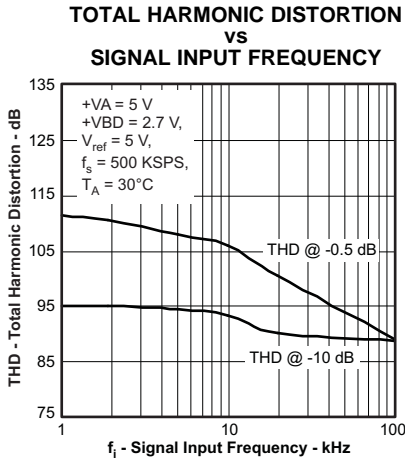

Figure 33.

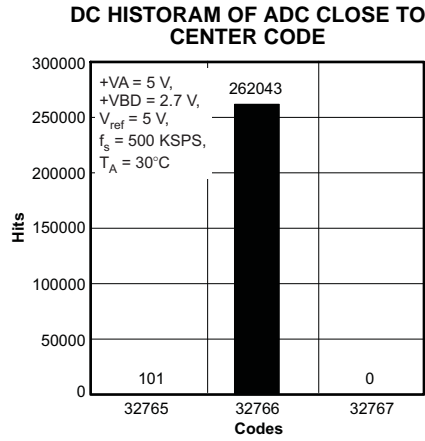

Figure 34.

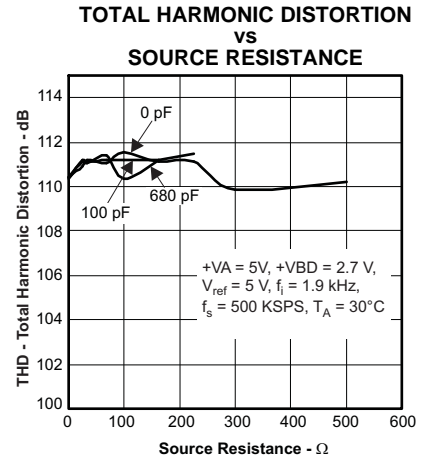

Figure 35.

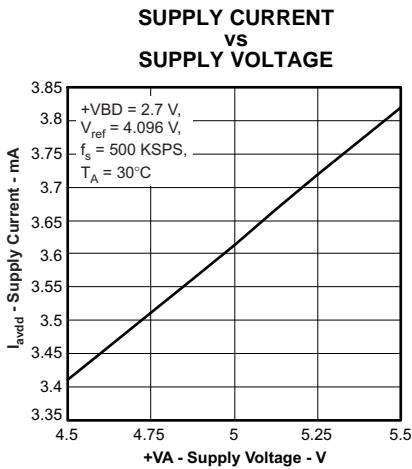

Figure 36.

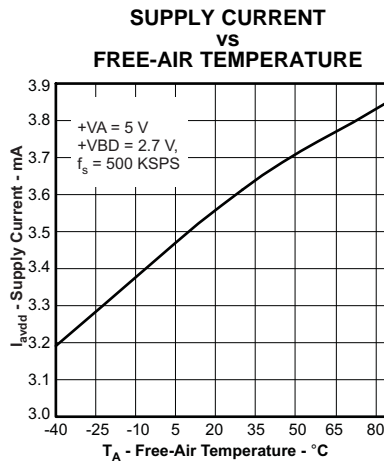

Figure 37.

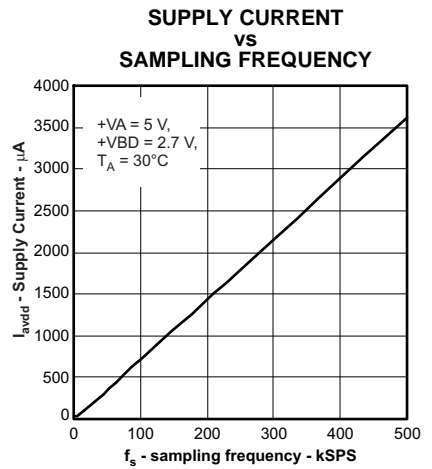

Figure 38.

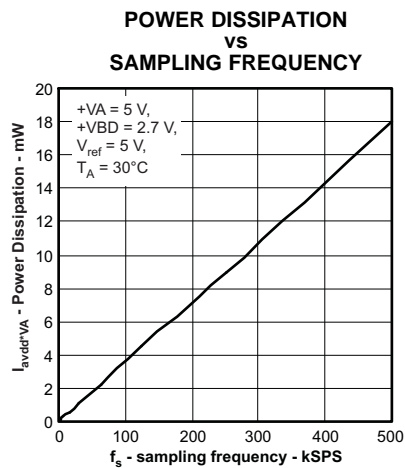

Figure 39.

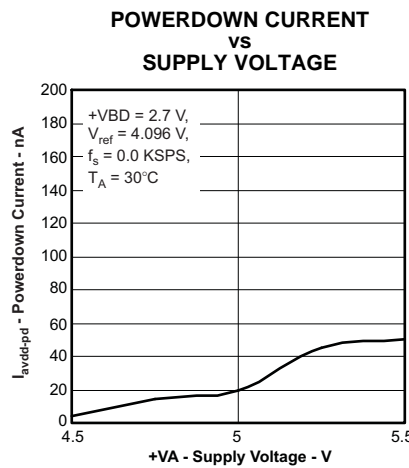

Figure 40.

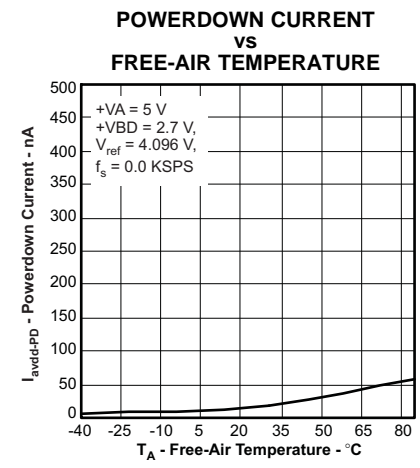

Figure 41.

TYPICAL CHARACTERISTICS (continued)

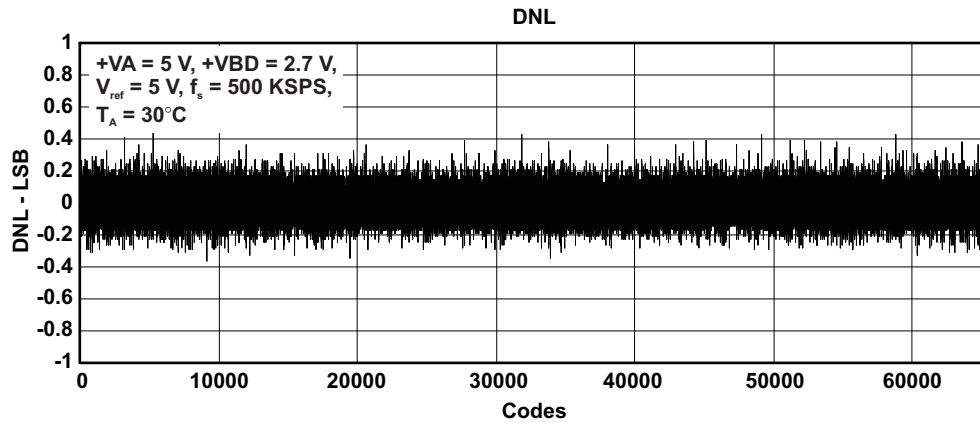

Figure 42.

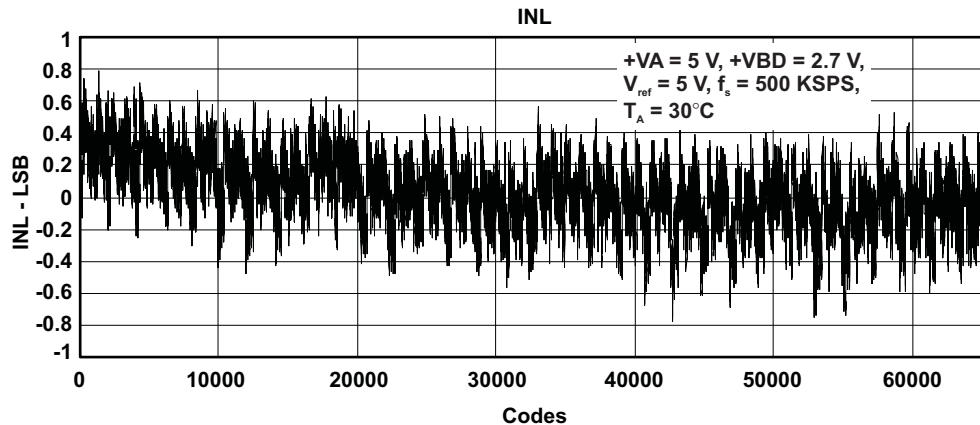

Figure 43.

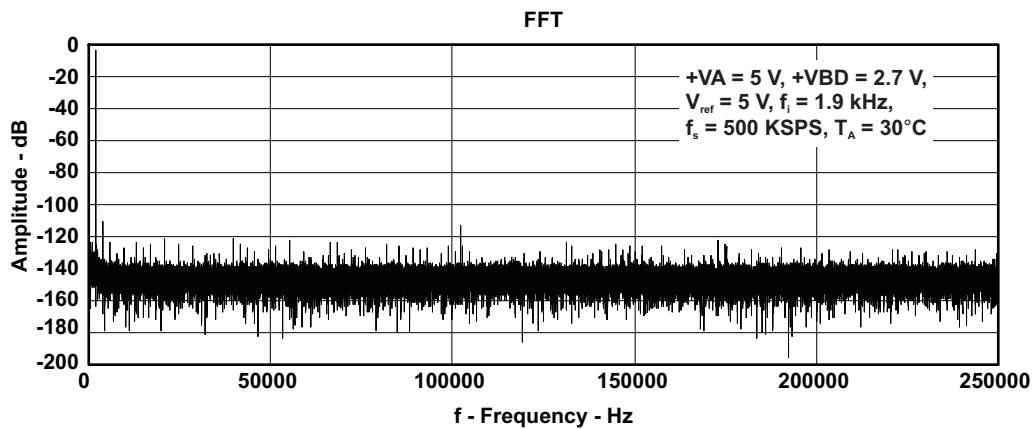

Figure 44.

DETAILED DESCRIPTIONS AND TIMING DIAGRAMS

The ADS8319 is a high-speed, low power, successive approximation register (SAR) analog-to-digital converter (ADC) that uses an external reference. The architecture is based on charge redistribution, which inherently includes a sample/hold function.

The ADS8319 is a single channel device. The analog input is provided to two input pins: +IN and -IN where -IN is a pseudo differential input and it has a limited range of ± 0.1 V. When a conversion is initiated, the differential input on these pins is sampled on the internal capacitor array. While a conversion is in progress, both +IN and -IN inputs are disconnected from any internal function.

The ADS8319 has an internal clock that is used to run the conversion, and hence the conversion requires a fixed amount of time. After a conversion is completed, the device reconnects the sampling capacitors to the +IN and -IN pins, and the device is in the acquisition phase. During this phase the device is powered down and conversion data can be read.

The device digital output is available in SPI compatible format. It easily interfaces with microprocessors, DSPs, or FPGAs.

This is a low pin count device; however, it offers six different options for the interface. They can be grossly classified as \overline{CS} mode (3- or 4-wire interface) and *daisy chain mode*. In both modes it can either be with or without a *busy indicator*, where the busy indicator is a bit preceding the 16-bit serial data.

The 3-wire interface \overline{CS} mode is useful for applications which need galvanic isolation on-board, where as 4-wire interface \overline{CS} mode makes it easy to control an individual device while having multiple devices on-board. The *daisy chain mode* is provided to hook multiple devices in a chain like a shift register and is useful to reduce component count and the number of signal traces on the board.

\overline{CS} MODE

\overline{CS} Mode is selected if SDI is high at the rising edge of \overline{CONVST} . As indicated before there are four different interface options available in this mode, namely 3-wire \overline{CS} mode without busy indicator, 3-wire \overline{CS} mode with busy indicator, 4-wire \overline{CS} mode without busy indicator, 4-wire \overline{CS} mode with busy indicator. The following section discusses these interface options in detail.

3-Wire \overline{CS} Mode Without Busy Indicator

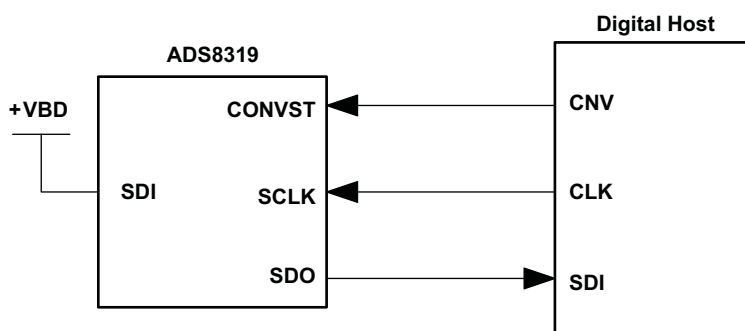

Figure 45. Connection Diagram, 3-Wire \overline{CS} Mode without Busy Indicator (SDI = 1)

The three wire interface option in \overline{CS} mode is selected if SDI is tied to +VBD (see Figure 45). In the three wire interface option, CONVST acts like \overline{CS} . As shown in Figure 46, the device samples the input signal and enters the conversion phase on the rising edge of CONVST, at the same time SDO goes to 3-state. Conversion is done with the internal clock and it continues irrespective of the state of CONVST. As a result it is possible to bring CONVST (acting as \overline{CS}) low after the start of the conversion to select other devices on the board. But it is absolutely necessary that CONVST is high again before the minimum conversion time (t_{cnv} in timing requirements table) is elapsed. A high level on CONVST at the end of the conversion ensures the device does not generate a busy indicator.

When the conversion is over, the device enters the acquisition phase and powers down. On the falling edge of CONVST, SDO comes out of three state, and the device outputs the MSB of the data. After this, the device outputs the next lower data bits on every falling edge of SCLK. SDO goes to 3-state after the 16th falling edge of SCLK or CONVST high, whichever occurs first. It is necessary that the device sees a minimum of 15 falling edges of SCLK during the low period of CONVST.

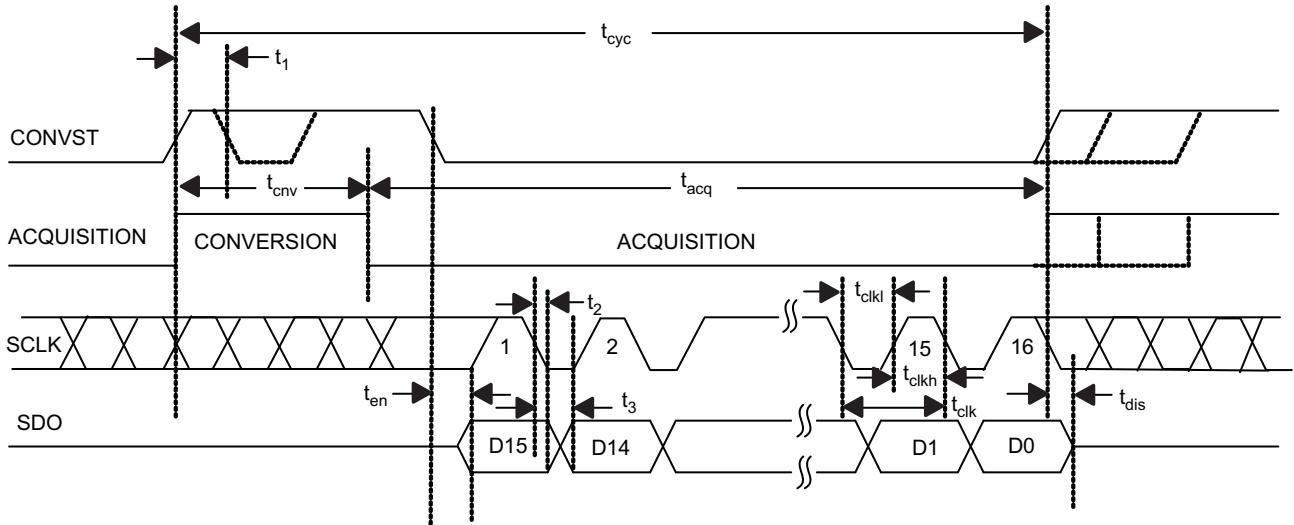

Figure 46. Interface Timing Diagram, 3 Wire $\overline{\text{CS}}$ Mode Without Busy Indicator (SDI = 1)

3 Wire $\overline{\text{CS}}$ Mode With Busy Indicator

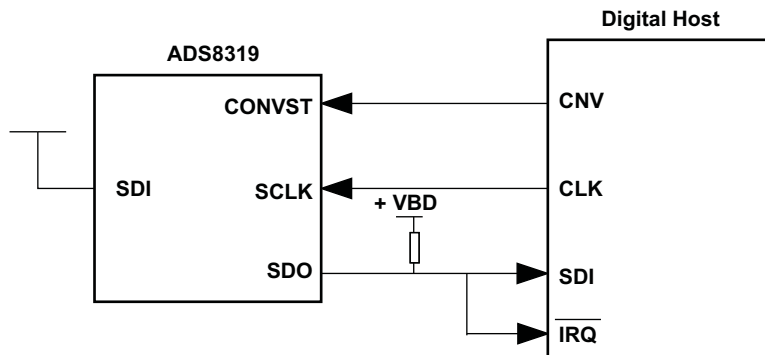

Figure 47. Connection Diagram, 3 Wire $\overline{\text{CS}}$ Mode With Busy Indicator

The three wire interface option in $\overline{\text{CS}}$ mode is selected if SDI is tied to +VBD (see Figure 47). In the three wire interface option, CONVST acts like $\overline{\text{CS}}$. As shown in Figure 48, the device samples the input signal and enters the conversion phase on the rising edge of CONVST, at the same time SDO goes to 3 state. Conversion is done with the internal clock and it continues irrespective of the state of CONVST. As a result it is possible to toggle CONVST (acting as $\overline{\text{CS}}$) after the start of the conversion to select other devices on the board. But it is absolutely necessary that CONVST is low again before the minimum conversion time (t_{cnv} in timing requirements table) is elapsed and continues to stay low until the end of maximum conversion time. A low level on the CONVST input at the end of a conversion ensures the device generates a busy indicator.

When the conversion is over, the device enters the acquisition phase and powers down, and the device forces SDO out of three state and outputs a busy indicator bit (low level). The device outputs the MSB of data on the first falling edge of SCLK after the conversion is over and continues to output the next lower data bits on every subsequent falling edge of SCLK. SDO goes to three state after the 17th falling edge of SCLK or CONVST high, whichever occurs first. It is necessary that the device sees a minimum of 16 falling edges of SCLK during the low period of CONVST.

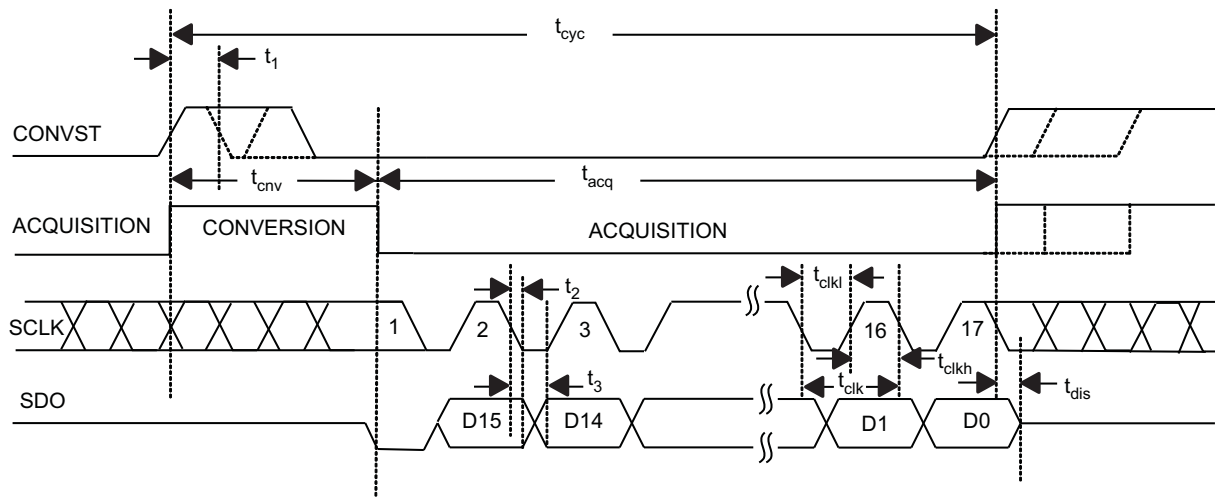

Figure 48. Interface Timing Diagram, 3 Wire \overline{CS} Mode With Busy Indicator (SDI = 1)

4 Wire \overline{CS} Mode Without Busy Indicator

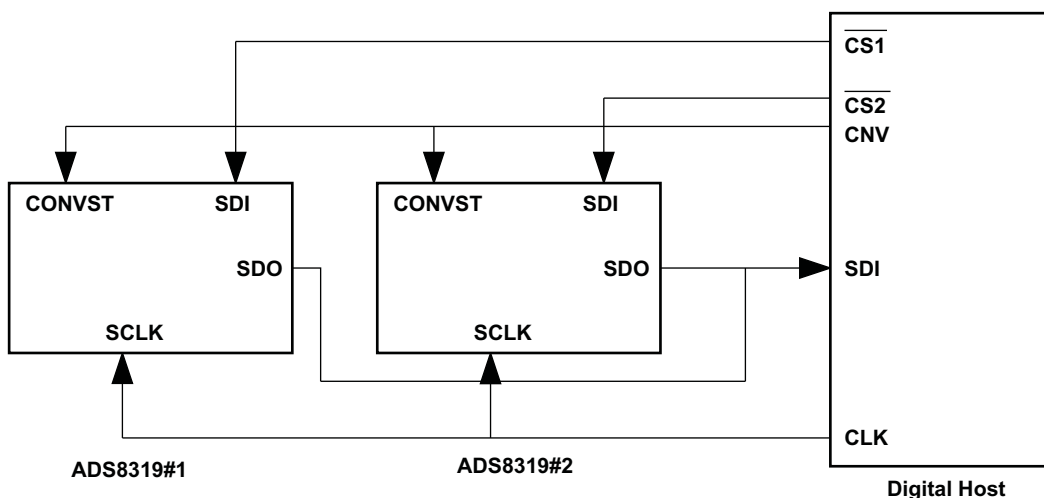

Figure 49. Connection Diagram, 4 Wire \overline{CS} Mode Without Busy Indicator

As mentioned before for selecting \overline{CS} mode it is necessary that SDI is high at the time of the CONVST rising edge. Unlike in *three wire interface option*, SDI is controlled by digital host and acts like \overline{CS} . As shown in [Figure 50](#), SDI goes to a high level before the rising edge of CONVST. The rising edge of CONVST while SDI is high selects CS mode, forces SDO to three state, samples the input signal, and the device enters the conversion phase. In the 4 wire interface option CONVST needs to be at a high level from the start of the conversion until all of the data bits are read. Conversion is done with the internal clock and it continues irrespective of the state of SDI. As a result it is possible to bring SDI (acting as \overline{CS}) low to select other devices on the board. But it is absolutely necessary that SDI is high again before the minimum conversion time (t_{cnv} in timing requirements table) is elapsed.

When the conversion is over, the device enters the acquisition phase and powers down. SDI falling edge can occur after the maximum conversion time (t_{cnv} in timing requirements table). Note that it is necessary that SDI is high at the end of the conversion, so that the device does not generate a *busy indicator*. The falling edge of SDI

brings SDO out of 3-state and the device outputs the MSB of the data. Subsequent to this the device outputs the next lower data bits on every falling edge of SCLK. SDO goes to three state after the 16th falling edge of SCLK or SDI (\overline{CS}) high, whichever occurs first. As shown in Figure 49, it is possible to hook multiple devices on the same data bus. In this case the second device SDI (acting as \overline{CS}) can go low after the first device data is read and device 1 SDO is in three state.

Care needs to be taken so that CONVST and SDI are not low together at any time during the cycle.

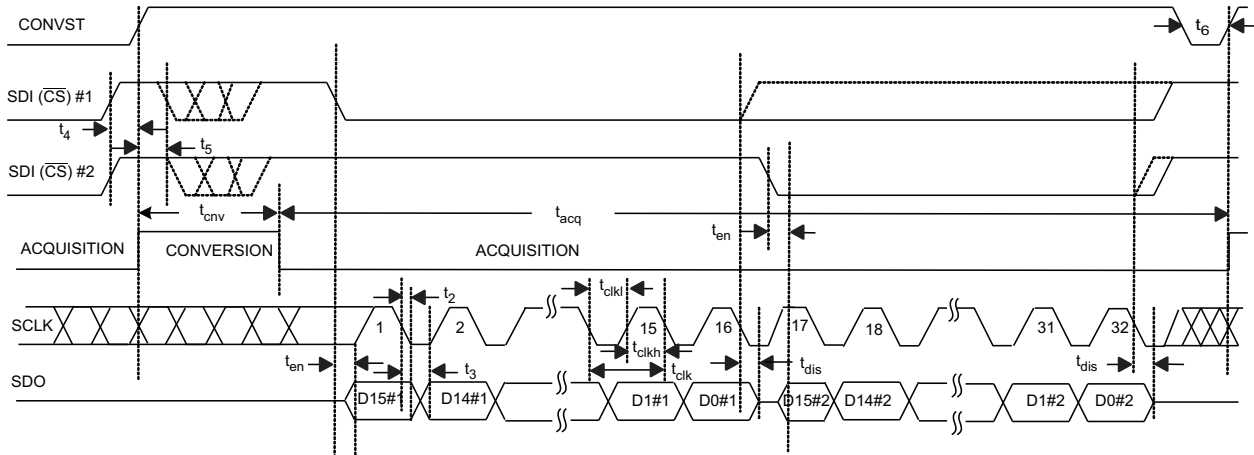

Figure 50. Interface Timing Diagram, 4 Wire \overline{CS} Mode Without Busy Indicator

4 Wire \overline{CS} Mode With Busy Indicator

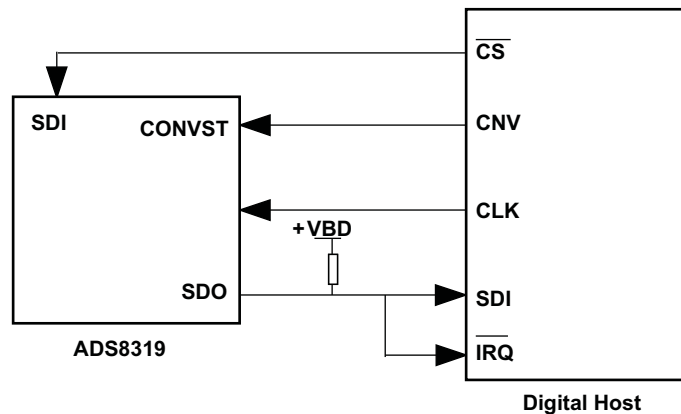

Figure 51. Connection Diagram, 4 Wire \overline{CS} Mode With Busy Indicator

As mentioned before for selecting \overline{CS} mode it is necessary that SDI is high at the time of the CONVST rising edge. Unlike in the three wire interface option, SDI is controlled by the digital host and acts like \overline{CS} . As shown in Figure 52, SDI goes to a high level before the rising edge of CONVST. The rising edge of CONVST while SDI is high selects \overline{CS} mode, forces SDO to three state, samples the input signal, and the device enters the conversion phase. In the 4 wire interface option CONVST needs to be at a high level from the start of the conversion until all of the data bits are read. Conversion is done with the internal clock and it continues irrespective of the state of SDI. As a result it is possible to toggle SDI (acting as \overline{CS}) to select other devices on the board. But it is absolutely necessary that SDI is low before the minimum conversion time (t_{cnv} in timing requirements table) is elapsed and continues to stay low until the end of the maximum conversion time. A low level on the SDI input at the end of a conversion ensures the device generates a busy indicator.

When the conversion is over, the device enters the acquisition phase and powers down, forces SDO out of three state, and outputs a busy indicator bit (low level). The device outputs the MSB of the data on the first falling edge of SCLK after the conversion is over and continues to output the next lower data bits on every falling edge of SCLK. SDO goes to three state after the 17th falling edge of SCLK or SDI (\overline{CS}) high, whichever occurs first.

Care needs to be taken so that CONVST and SDI are not low together at any time during the cycle.

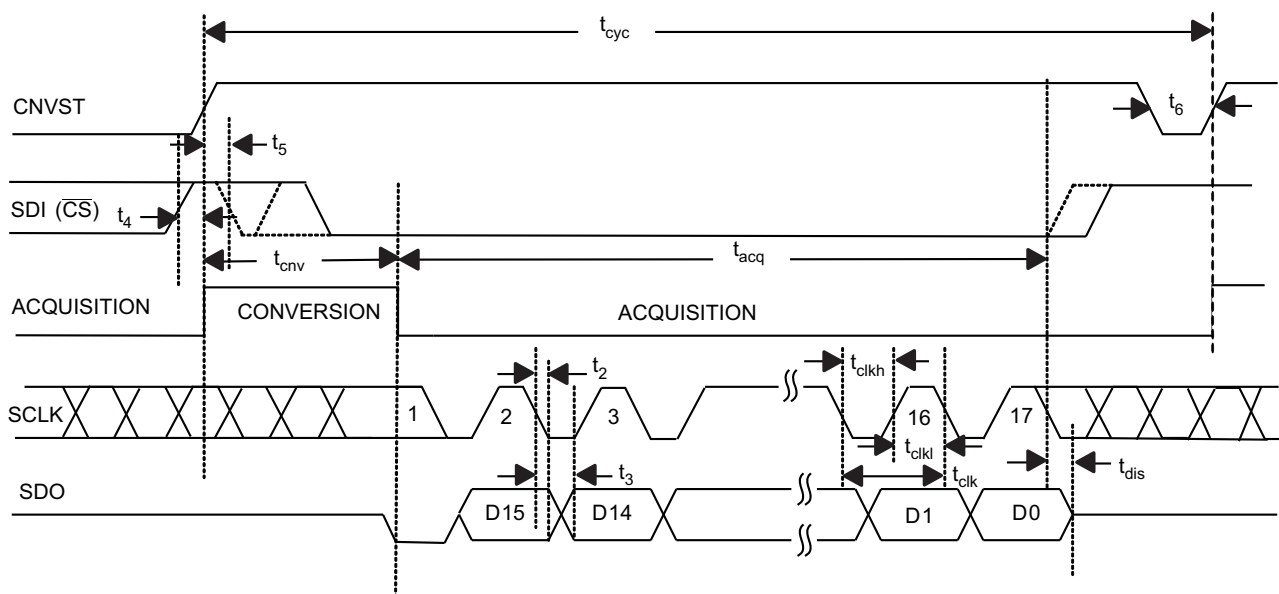

Figure 52. Interface Timing Diagram, 4 Wire $\overline{\text{CS}}$ Mode With Busy Indicator

Daisy Chain Mode

Daisy chain mode is selected if SDI is low at the time of CONVST rising edge. This mode is useful to reduce wiring and hardware like digital isolators in the applications where multiple (ADC) devices are used. In this mode all of the devices are connected in a chain (SDO of one device connected to the SDI of the next device) and data transfer is analogous to a shift register.

Like $\overline{\text{CS}}$ mode even this mode offers operation with or without a busy indicator. The following section discusses these interface options in detail.

Daisy Chain Mode Without Busy Indicator

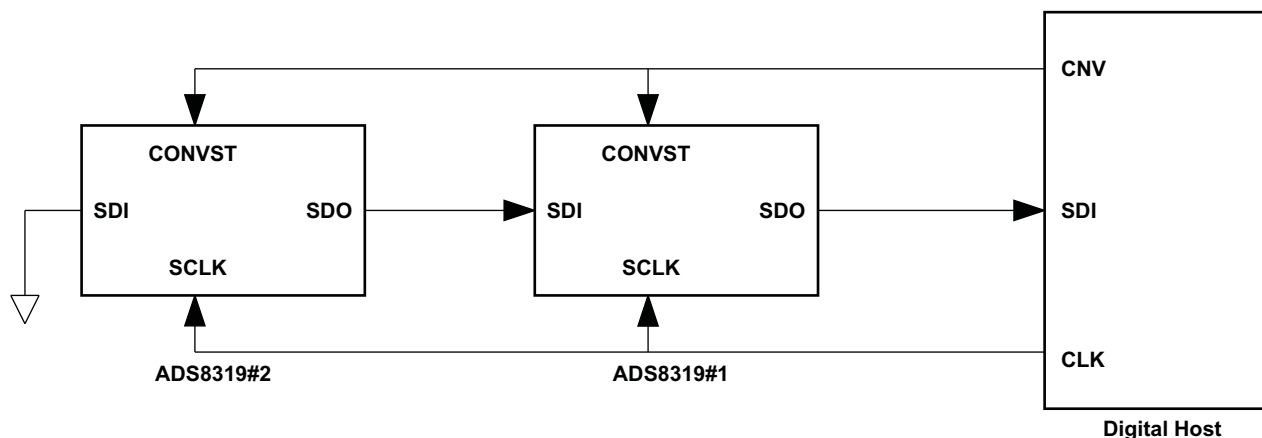

Figure 53. Connection Diagram, Daisy Chain Mode Without Busy Indicator (SDI = 0)

Refer to Figure 53 for the connection diagram. SDI for device 1 is tied to ground and SDO of device 1 goes to SDI of device 2 and so on. SDO of the last device in the chain goes to the digital host. CONVST for all of the

devices in the chain are tied together. In this mode there is no \overline{CS} signal. The device SDO is driven low when SDI low selects daisy chain mode and the device samples the analog input and enters the conversion phase. It is necessary that SCLK is low at the rising edge of CONVST so that the device does not generate a busy indicator at the end of the conversion. In this mode CONVST continues to be high from the start of the conversion until all of the data bits are read. Once started, conversion continues irrespective of the state of SCLK.

At the end of the conversion, every device in the chain initiates output of its conversion data starting with the MSB bit. Further the next lower data bit is output on every falling edge of SCLK. While every device outputs its data on the SDO pin, it also receives previous device data on the SDI pin (other than device #1) and stores it in the shift register. The device latches incoming data on every falling edge of SCLK. SDO of the first device in the chain goes low after the 16th falling edge of SCLK. All subsequent devices in the chain output the stored data from the previous device in MSB first format immediately following their own data word.

It needs $16 \times N$ clocks to read data for N devices in the chain.

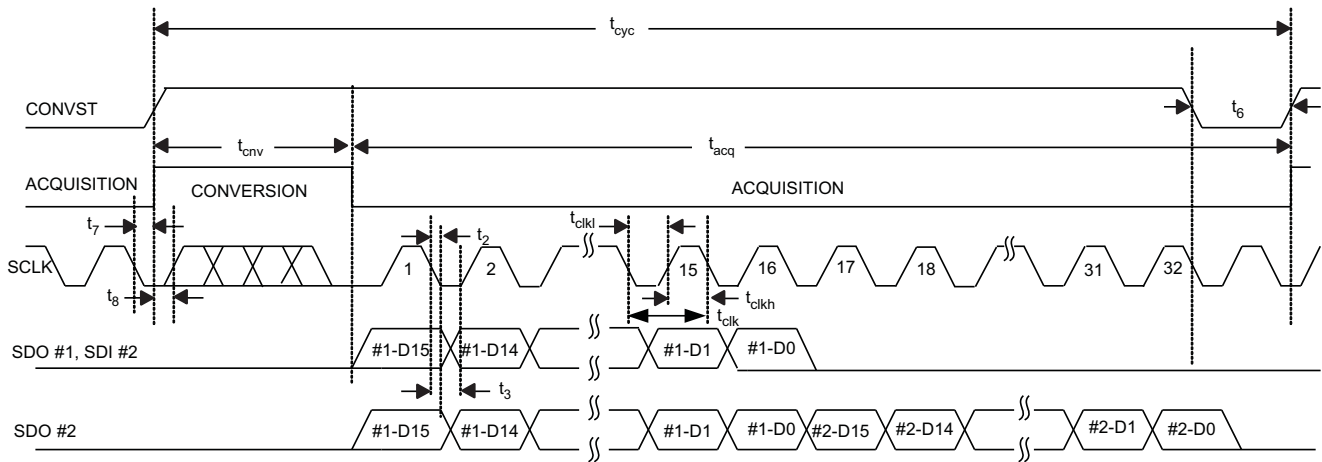

Figure 54. Interface Timing Diagram, Daisy Chain Mode Without Busy Indicator

Daisy Chain Mode With Busy Indicator

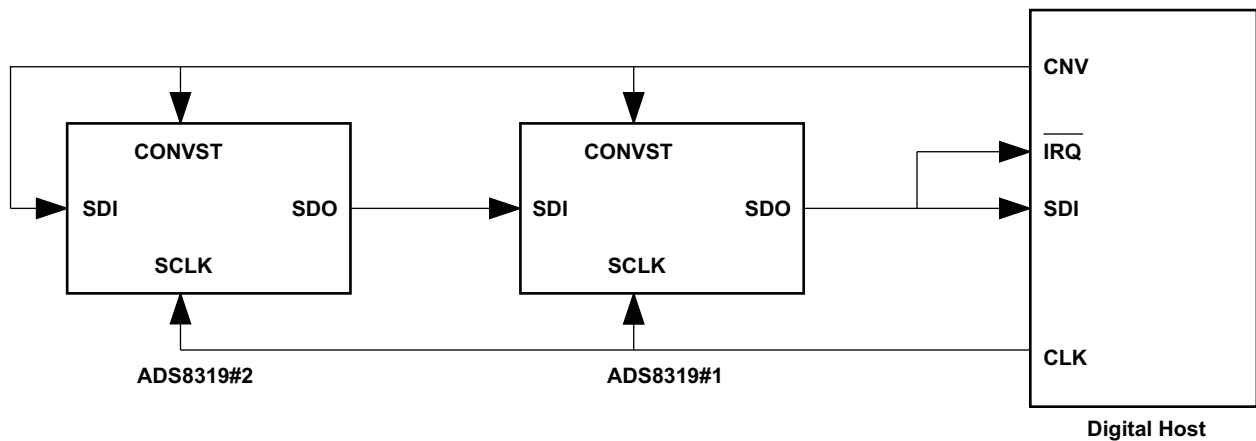

Figure 55. Connection Diagram, Daisy Chain Mode With Busy Indicator (SDI = 0)

Refer to Figure 55 for the connection diagram. SDI for device 1 is wired to its CONVST and CONVST for all the devices in the chain are wired together. SDO of device 1 goes to SDI of device 2 and so on. SDO of the last device in the chain goes to the digital host. In this mode there is no \overline{CS} signal. On the rising edge of CONVST, all of the device in the chain sample the analog input and enter the conversion phase. For the first device, SDI

and CONVST are wired together, and the setup time of SDI to rising edge of CONVST is adjusted so that the device still enters chain mode even though SDI and CONVST rise together. It is necessary that SCLK is high at the rising edge of CONVST so that the device generates a busy indicator at the end of the conversion. In this mode, CONVST continues to be high from the start of the conversion until all of the data bits are read. Once started, conversion continues irrespective of the state of SCLK.

At the end of the conversion, all the devices in the chain generate busy indicators. On the first falling edge of SCLK following the busy indicator bit, all of the devices in the chain output their conversion data starting with the MSB bit. After this the next lower data bit is output on every falling edge of SCLK. While every device outputs its data on the SDO pin, it also receives the previous device data on the SDI pin (except for device #1) and stores it in the shift register. Each device latches incoming data on every falling edge of SCLK. SDO of the first device in the chain goes high after the 17th falling edge of SCLK. All subsequent devices in the chain output the stored data from the pervious device in MSB first format immediately following their own data word. It needs $16 \times N + 1$ clock pulses to read data for N devices in the chain.

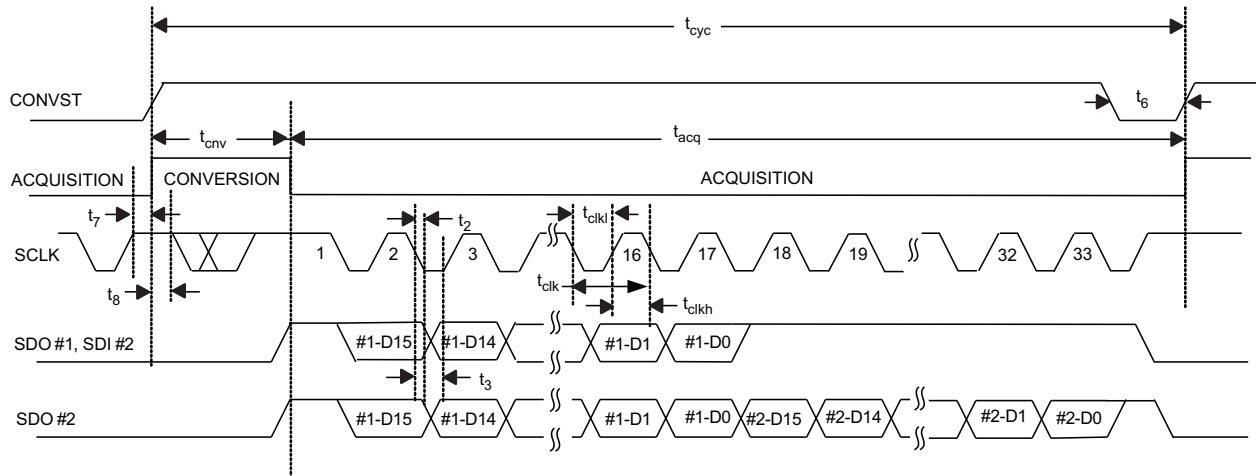

Figure 56. Interface Timing Diagram, Daisy Chain Mode With Busy Indicator

APPLICATION INFORMATION

ANALOG INPUT

When the converter samples the input, the voltage difference between the +IN and -IN inputs is captured on the internal capacitor array. The voltage on the +IN is limited between GND -0.1 V and $V_{ref} + 0.1$ V and on -IN is limited between GND -0.1 to GND $+0.1$ V; where as the differential signal range is $[(+IN) - (-IN)]$. This allows the input to reject small signals which are common to both the +IN and $-IN$ inputs.

The (peak) input current through the analog inputs depends upon a number of factors: sample rate, input voltage, and source impedance. The current into the ADS8319 charges the internal capacitor array during the sample period. After this capacitance has been fully charged, there is no further input current. The source of the analog input voltage must be able to charge the input capacitance (59 pF) to a 18-bit settling level within the minimum acquisition time. When the converter goes into hold mode, the input impedance is greater than 1 G Ω .

Care must be taken regarding the absolute analog input voltage. To maintain linearity of the converter, the +IN and -IN inputs and the span $(+IN - (-IN))$ should be within the limits specified. Outside of these ranges, converter linearity may not meet specifications.

Care should be taken to ensure that the output impedance of the sources driving the +IN and $-IN$ inputs are matched. If this is not observed, the two inputs could have different settling times. This may result in an offset error, gain error, and linearity error which change with temperature and input voltage. Typically the -IN input is grounded at the input decoupling capacitor.

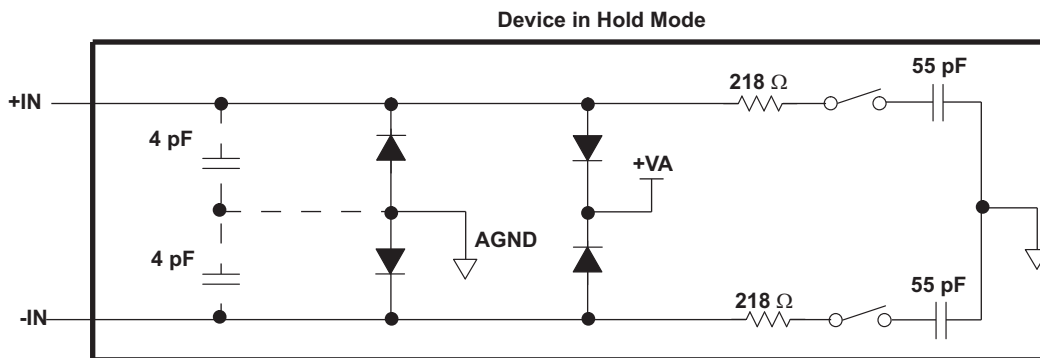

Figure 57. Input Equivalent Circuit

DRIVER AMPLIFIER CHOICE

The analog input to the converter needs to be driven with a low noise, op-amp like the THS4031, OPA211. An RC filter is recommended at the input pins to low-pass filter the noise from the source. A resistor of 5 Ω and a capacitor of 1nF is recommended. The input to the converter is a unipolar input voltage in the range 0 V to V_{ref} . The minimum -3 dB bandwidth of the driving operational amplifier can be calculated as:

$$f_{3db} = (\ln(2) \times (n+2)) / (2\pi \times t_{ACQ})$$

where n is equal to 16, the resolution of the ADC (in the case of the ADS8319). When $t_{ACQ} = 600$ ns (minimum acquisition time), the minimum bandwidth of the driving circuit is ~ 3 MHz (including RC following the driver OPA). The bandwidth can be relaxed if the acquisition time is increased by the application.

Typically a low noise OPA with ten times or higher bandwidth is selected. The driving circuit bandwidth is adjusted (to the required value) with a RC following the OPA. The OPA211 or THS4031 from Texas Instruments is recommended for driving high-resolution high-speed ADCs.

DRIVER AMPLIFIER CONFIGURATIONS

It is better to use a unity gain, noninverting buffer configuration. As explained before a RC following the OPA limits the input circuit bandwidth just enough for 16-bit settling. Note higher bandwidth reduces the settling time (beyond what is needed) but increases the noise in the ADC sampled signal, and hence the ADC output.

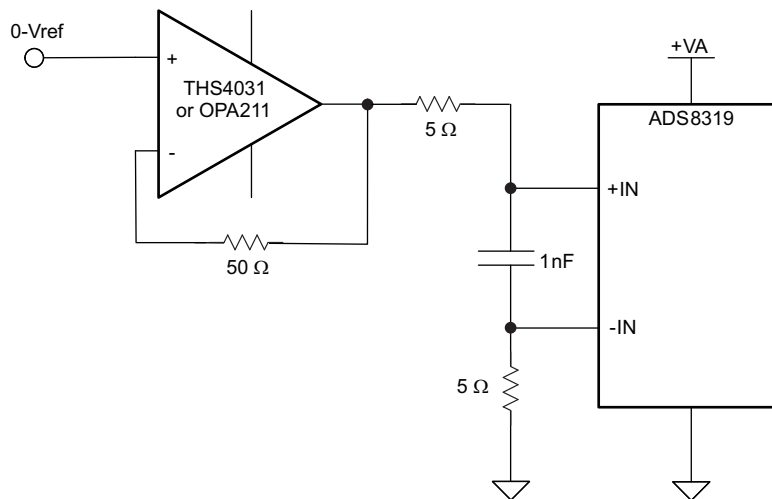

Figure 58. Input Drive Configuration

REFERENCE

The ADS8319 can operate with an external reference with a range from 2.25 V to $V_{DD} + 0.1$ V. A clean, low noise, well-decoupled reference voltage on this pin is required to ensure good performance of the converter. A low noise band-gap reference like the REF5040, REF5050 can be used to drive this pin. A ceramic decoupling capacitor is required between the REF+ and GND pins of the converter (see Figure 59). The capacitor should be placed as close as possible to the pins of the device.

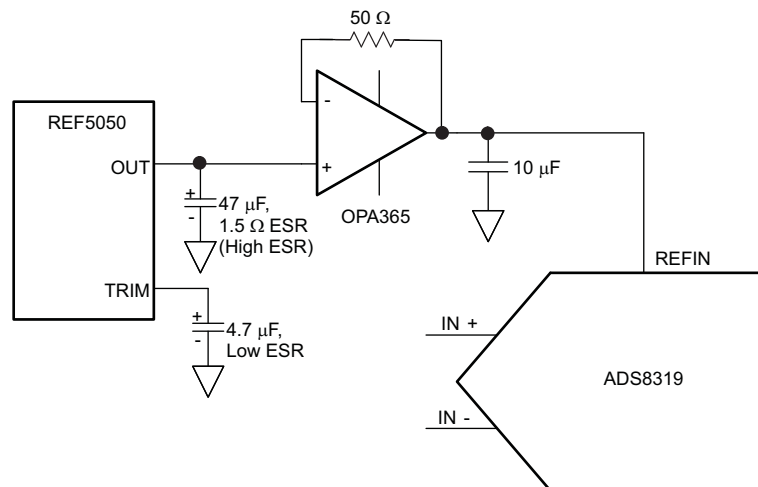

Figure 59. External Reference Driving Circuit

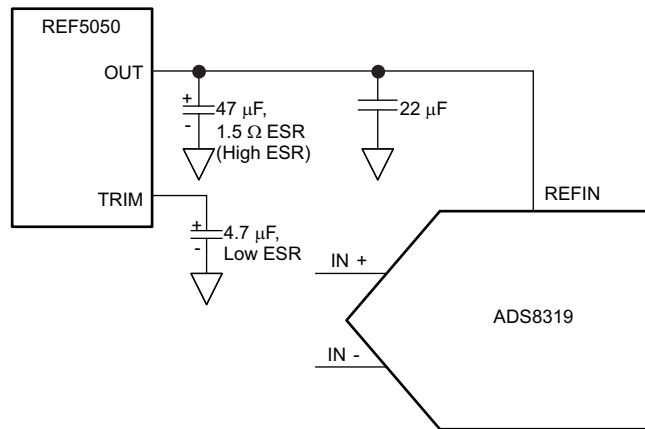

Figure 60. Direct External Reference Driving Circuit

POWER SAVING

The ADS8319 has an auto power-down feature. The device powers down at the end of every conversion. The input signal is acquired on sampling capacitors while the device is in the power-down state, and at the same time the conversion results are available for reading. The device powers up by itself on the start of the conversion. As discussed before, the conversion runs on an internal clock and takes a fixed time. As a result, device power consumption is directly proportional to the speed of operation.

DIGITAL OUTPUT

As discussed before (in the *DESCRIPTION* and *TIMING DIAGRAMS* sections) the device digital output is SPI compatible. The following table lists the output codes corresponding to various analog input voltages.

DESCRIPTION	ANALOG VALUE (V)	DIGITAL OUTPUT STRAIGHT BINARY	
		BINARY CODE	HEX CODE
Full-scale range	V_{ref}		
Least significant bit (LSB)	$V_{ref}/65536$		
Positive full scale	$+V_{ref} - 1 \text{ LSB}$	1111 1111 1111 1111	FFFF
Midscale	$V_{ref}/2$	1000 0000 0000 0000	8000
Midscale – 1 LSB	$V_{ref}/2 - 1 \text{ LSB}$	0111 1111 1111 1111	7FFF
Zero	0	0000 0000 0000 0000	0000

SCLK INPUT

The device uses SCLK for serial data output. Data is read after the conversion is over and the device is in the acquisition phase. It is possible to use a free running SCLK for the device, but it is recommended to stop the clock during a conversion, as the clock edges can couple with the internal analog circuit and can affect conversion results.

PACKAGING INFORMATION

Orderable Device	Status ⁽¹⁾	Package Type	Package Drawing	Pins	Package Qty	Eco Plan ⁽²⁾	Lead/Ball Finish	MSL Peak Temp ⁽³⁾
ADS8319IBDGSR	ACTIVE	MSOP	DGS	10	2500	Green (RoHS & no Sb/Br)	CU NIPDAU	Level-2-260C-1 YEAR
ADS8319IBDGST	ACTIVE	MSOP	DGS	10	250	Green (RoHS & no Sb/Br)	CU NIPDAU	Level-2-260C-1 YEAR
ADS8319IBDRCR	ACTIVE	SON	DRC	10	3000	Green (RoHS & no Sb/Br)	CU NIPDAU	Level-3-260C-168 HR
ADS8319IBDRCT	ACTIVE	SON	DRC	10	250	Green (RoHS & no Sb/Br)	CU NIPDAU	Level-3-260C-168 HR
ADS8319IDGSR	ACTIVE	MSOP	DGS	10	2500	Green (RoHS & no Sb/Br)	CU NIPDAU	Level-2-260C-1 YEAR
ADS8319IDGST	ACTIVE	MSOP	DGS	10	250	Green (RoHS & no Sb/Br)	CU NIPDAU	Level-2-260C-1 YEAR
ADS8319IDRCR	ACTIVE	SON	DRC	10	3000	Green (RoHS & no Sb/Br)	CU NIPDAU	Level-3-260C-168 HR
ADS8319IDRCT	ACTIVE	SON	DRC	10	250	Green (RoHS & no Sb/Br)	CU NIPDAU	Level-3-260C-168 HR

⁽¹⁾ The marketing status values are defined as follows:

ACTIVE: Product device recommended for new designs.

LIFEBUY: TI has announced that the device will be discontinued, and a lifetime-buy period is in effect.

NRND: Not recommended for new designs. Device is in production to support existing customers, but TI does not recommend using this part in a new design.

PREVIEW: Device has been announced but is not in production. Samples may or may not be available.

OBSOLETE: TI has discontinued the production of the device.

⁽²⁾ Eco Plan - The planned eco-friendly classification: Pb-Free (RoHS), Pb-Free (RoHS Exempt), or Green (RoHS & no Sb/Br) - please check <http://www.ti.com/productcontent> for the latest availability information and additional product content details.

TBD: The Pb-Free/Green conversion plan has not been defined.

Pb-Free (RoHS): TI's terms "Lead-Free" or "Pb-Free" mean semiconductor products that are compatible with the current RoHS requirements for all 6 substances, including the requirement that lead not exceed 0.1% by weight in homogeneous materials. Where designed to be soldered at high temperatures, TI Pb-Free products are suitable for use in specified lead-free processes.

Pb-Free (RoHS Exempt): This component has a RoHS exemption for either 1) lead-based flip-chip solder bumps used between the die and package, or 2) lead-based die adhesive used between the die and leadframe. The component is otherwise considered Pb-Free (RoHS compatible) as defined above.

Green (RoHS & no Sb/Br): TI defines "Green" to mean Pb-Free (RoHS compatible), and free of Bromine (Br) and Antimony (Sb) based flame retardants (Br or Sb do not exceed 0.1% by weight in homogeneous material)

⁽³⁾ MSL, Peak Temp. -- The Moisture Sensitivity Level rating according to the JEDEC industry standard classifications, and peak solder temperature.

Important Information and Disclaimer:The information provided on this page represents TI's knowledge and belief as of the date that it is provided. TI bases its knowledge and belief on information provided by third parties, and makes no representation or warranty as to the accuracy of such information. Efforts are underway to better integrate information from third parties. TI has taken and continues to take reasonable steps to provide representative and accurate information but may not have conducted destructive testing or chemical analysis on incoming materials and chemicals. TI and TI suppliers consider certain information to be proprietary, and thus CAS numbers and other limited information may not be available for release.

In no event shall TI's liability arising out of such information exceed the total purchase price of the TI part(s) at issue in this document sold by TI to Customer on an annual basis.

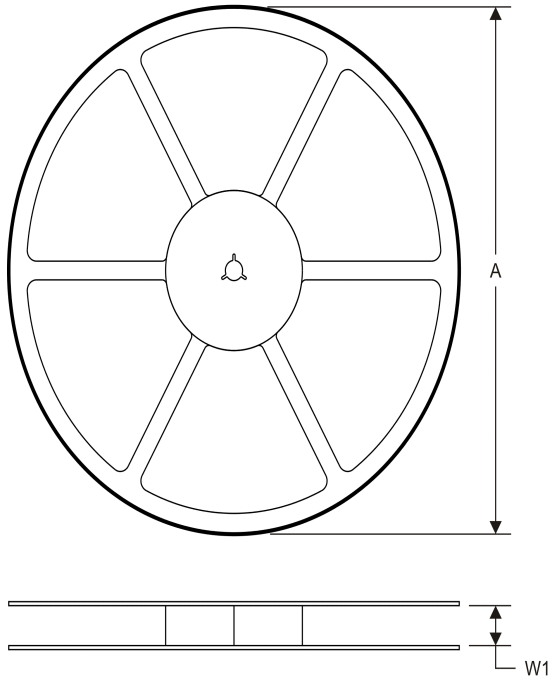
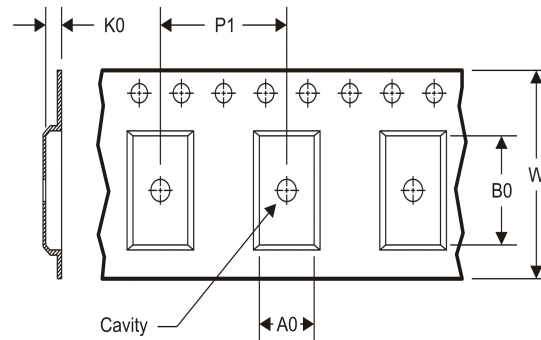
TAPE AND REEL INFORMATION
REEL DIMENSIONS

TAPE DIMENSIONS

A0	Dimension designed to accommodate the component width
B0	Dimension designed to accommodate the component length
K0	Dimension designed to accommodate the component thickness
W	Overall width of the carrier tape
P1	Pitch between successive cavity centers

TAPE AND REEL INFORMATION

*All dimensions are nominal

Device	Package Type	Package Drawing	Pins	SPQ	Reel Diameter (mm)	Reel Width W1 (mm)	A0 (mm)	B0 (mm)	K0 (mm)	P1 (mm)	W (mm)	Pin1 Quadrant
ADS8319IBDGST	MSOP	DGS	10	250	330.0	12.4	5.3	3.4	1.4	8.0	12.0	Q1
ADS8319IBDRCR	SON	DRC	10	3000	330.0	12.4	3.3	3.3	1.1	8.0	12.0	Q2
ADS8319IBDRCT	SON	DRC	10	250	330.0	12.4	3.3	3.3	1.1	8.0	12.0	Q2
ADS8319IDGSR	MSOP	DGS	10	2500	330.0	12.4	5.3	3.4	1.4	8.0	12.0	Q1
ADS8319IDGST	MSOP	DGS	10	250	330.0	12.4	5.3	3.4	1.4	8.0	12.0	Q1
ADS8319IDRCR	SON	DRC	10	3000	330.0	12.4	3.3	3.3	1.1	8.0	12.0	Q2
ADS8319IDRCT	SON	DRC	10	250	330.0	12.4	3.3	3.3	1.1	8.0	12.0	Q2

TAPE AND REEL BOX DIMENSIONS

*All dimensions are nominal

Device	Package Type	Package Drawing	Pins	SPQ	Length (mm)	Width (mm)	Height (mm)
ADS8319IBDGST	MSOP	DGS	10	250	367.0	367.0	35.0
ADS8319IBDRCR	SON	DRC	10	3000	338.1	338.1	20.6
ADS8319IBDRCT	SON	DRC	10	250	338.1	338.1	20.6
ADS8319IDGSR	MSOP	DGS	10	2500	367.0	367.0	35.0
ADS8319IDGST	MSOP	DGS	10	250	367.0	367.0	35.0
ADS8319IDRCR	SON	DRC	10	3000	338.1	338.1	20.6
ADS8319IDRCT	SON	DRC	10	250	338.1	338.1	20.6

DGS (S-PDSO-G10)

PLASTIC SMALL-OUTLINE PACKAGE

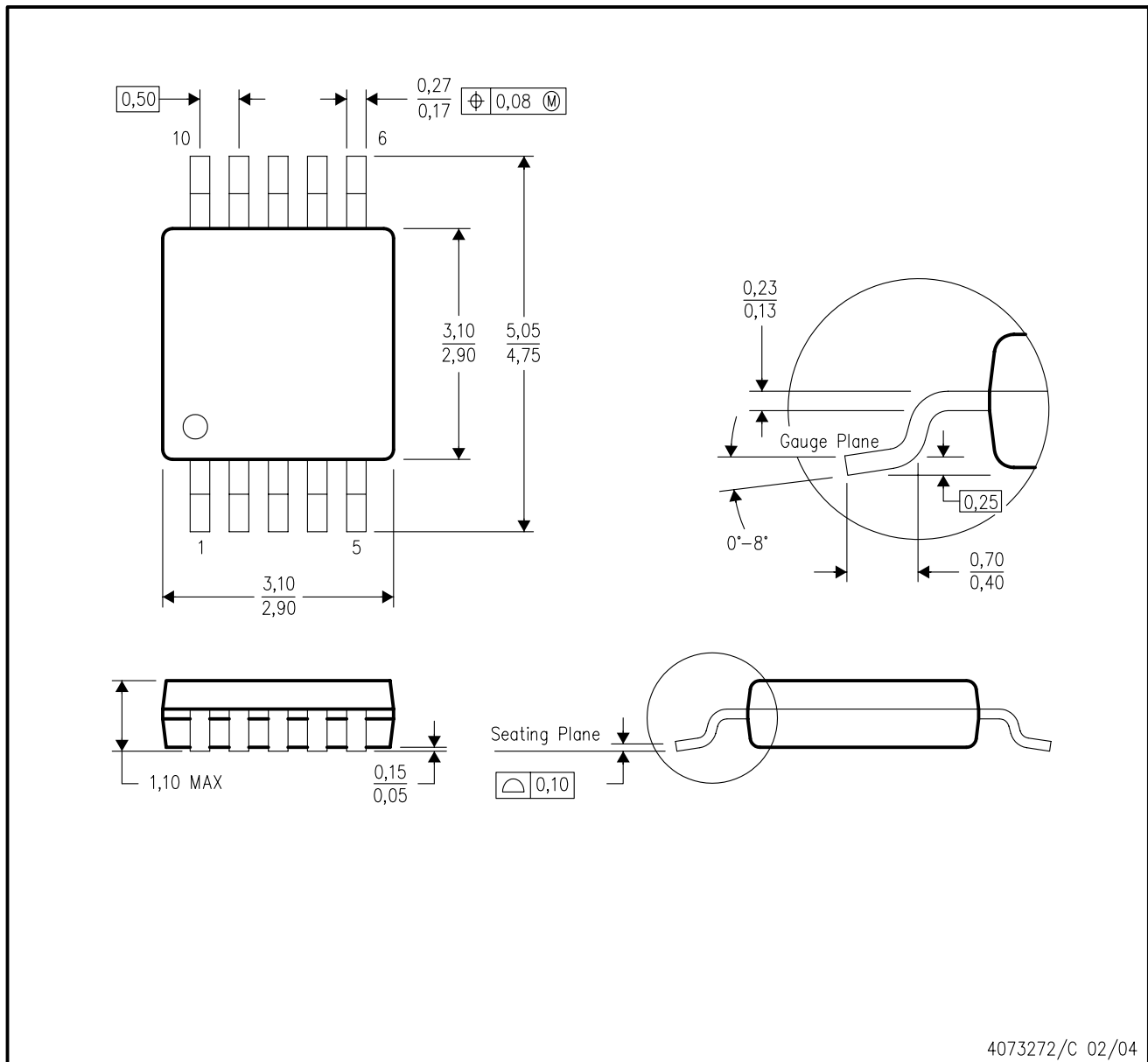

- NOTES:
- A. All linear dimensions are in millimeters.
 - B. This drawing is subject to change without notice.
 - C. Body dimensions do not include mold flash or protrusion.
 - D. Falls within JEDEC MO-187 variation BA.

DRC (S-PVSON-N10)

PLASTIC SMALL OUTLINE NO-LEAD



- NOTES:
- All linear dimensions are in millimeters. Dimensioning and tolerancing per ASME Y14.5M-1994.
 - This drawing is subject to change without notice.
 - Small Outline No-Lead (SON) package configuration.
 - The package thermal pad must be soldered to the board for thermal and mechanical performance, if present.
 - See the additional figure in the Product Data Sheet for details regarding the exposed thermal pad features and dimensions, if present.

THERMAL PAD MECHANICAL DATA

DRC (S-PVSON-N10)

PLASTIC SMALL OUTLINE NO-LEAD

THERMAL INFORMATION

This version of the package has no exposed thermal pad. This must be accounted for when estimating thermal performance.

For information on the Quad Flatpack No-Lead (QFN) package and its advantages, refer to Application Report, QFN/SON PCB Attachment, Texas Instruments Literature No. SLUA271. This document is available at www.ti.com.

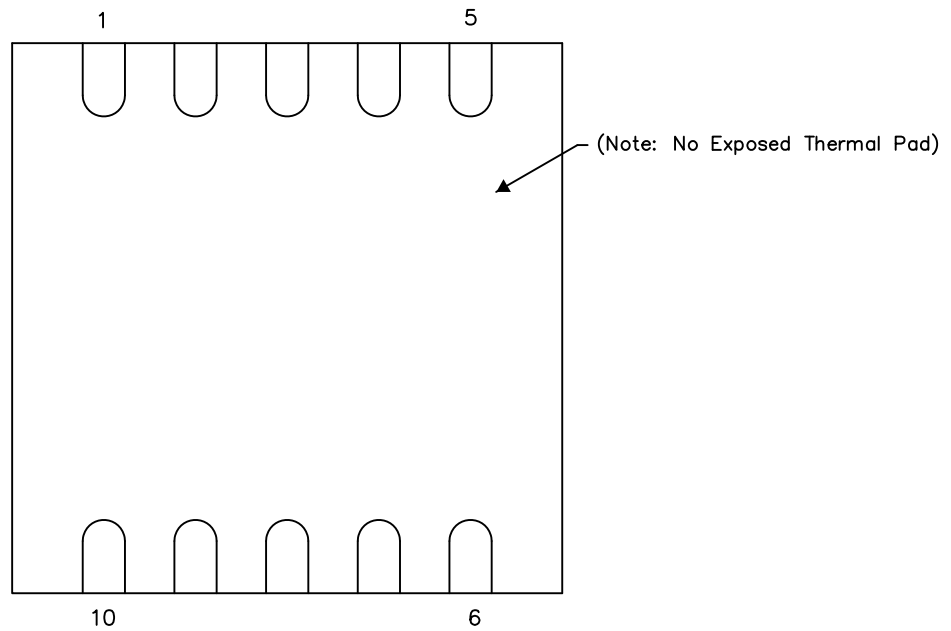

Bottom View

4206565-5/N 07/12

DRC (S-PVSON-N10)

PLASTIC SMALL OUTLINE NO-LEAD

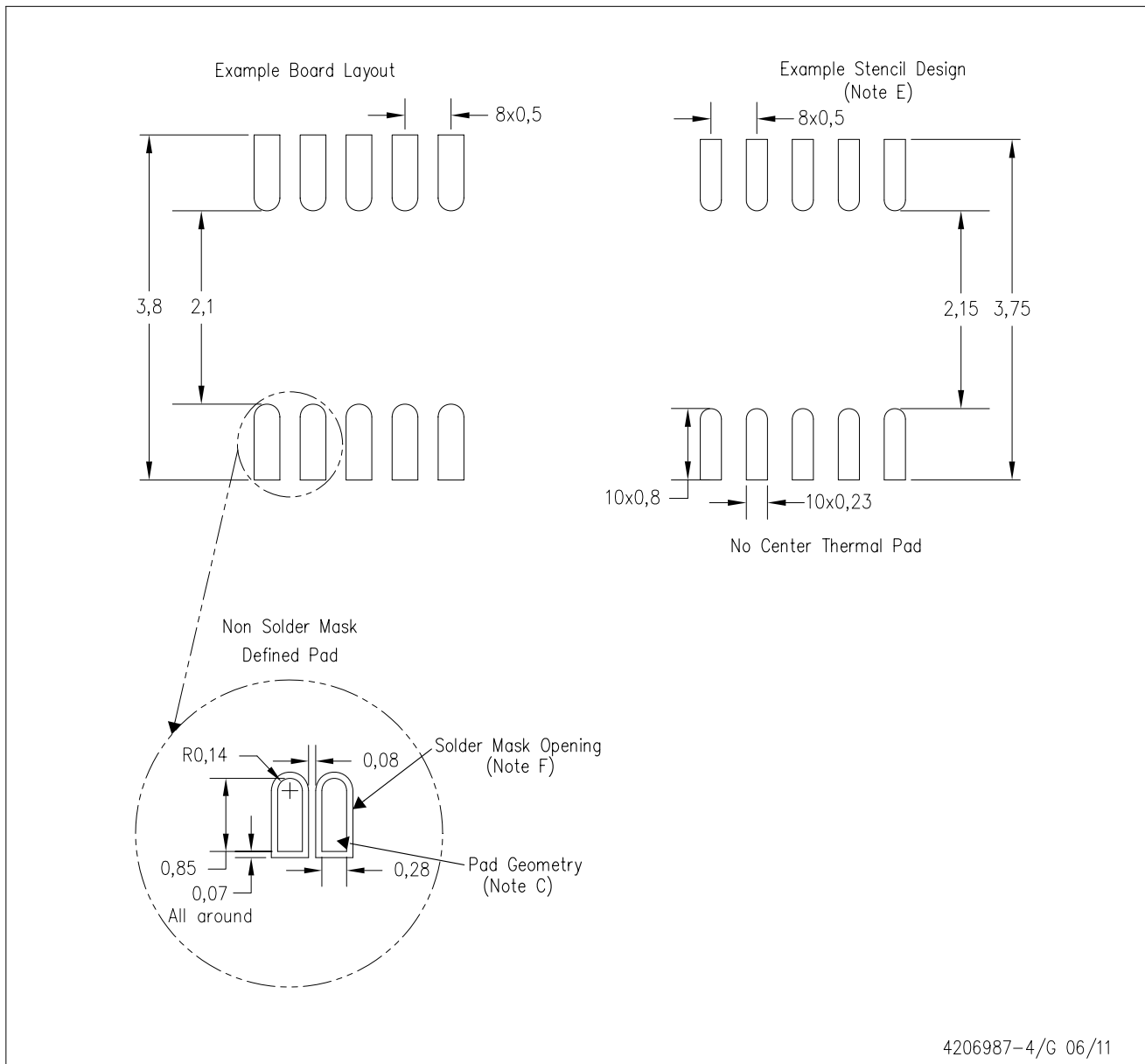

- NOTES:
- A. All linear dimensions are in millimeters.
 - B. This drawing is subject to change without notice.
 - C. Publication IPC-7351 is recommended for alternate designs.
 - D. This package does not have a center thermal pad. Refer to Application Note, Quad Flat-Pack Packages, Texas Instruments Literature No. SLUA271, and also the Product Data Sheets for specific thermal information, via requirements, and recommended board layout. These documents are available at www.ti.com <<http://www.ti.com>>.
 - E. Laser cutting apertures with trapezoidal walls and also rounding corners will offer better paste release. Customers should contact their board assembly site for stencil design recommendations. Refer to IPC 7525 for stencil design considerations.
 - F. Customers should contact their board fabrication site for minimum solder mask web tolerances between signal pads.

IMPORTANT NOTICE

Texas Instruments Incorporated and its subsidiaries (TI) reserve the right to make corrections, enhancements, improvements and other changes to its semiconductor products and services per JESD46C and to discontinue any product or service per JESD48B. Buyers should obtain the latest relevant information before placing orders and should verify that such information is current and complete. All semiconductor products (also referred to herein as "components") are sold subject to TI's terms and conditions of sale supplied at the time of order acknowledgment.

TI warrants performance of its components to the specifications applicable at the time of sale, in accordance with the warranty in TI's terms and conditions of sale of semiconductor products. Testing and other quality control techniques are used to the extent TI deems necessary to support this warranty. Except where mandated by applicable law, testing of all parameters of each component is not necessarily performed.

TI assumes no liability for applications assistance or the design of Buyers' products. Buyers are responsible for their products and applications using TI components. To minimize the risks associated with Buyers' products and applications, Buyers should provide adequate design and operating safeguards.

TI does not warrant or represent that any license, either express or implied, is granted under any patent right, copyright, mask work right, or other intellectual property right relating to any combination, machine, or process in which TI components or services are used. Information published by TI regarding third-party products or services does not constitute a license to use such products or services or a warranty or endorsement thereof. Use of such information may require a license from a third party under the patents or other intellectual property of the third party, or a license from TI under the patents or other intellectual property of TI.

Reproduction of significant portions of TI information in TI data books or data sheets is permissible only if reproduction is without alteration and is accompanied by all associated warranties, conditions, limitations, and notices. TI is not responsible or liable for such altered documentation. Information of third parties may be subject to additional restrictions.

Resale of TI components or services with statements different from or beyond the parameters stated by TI for that component or service voids all express and any implied warranties for the associated TI component or service and is an unfair and deceptive business practice. TI is not responsible or liable for any such statements.

Buyer acknowledges and agrees that it is solely responsible for compliance with all legal, regulatory and safety-related requirements concerning its products, and any use of TI components in its applications, notwithstanding any applications-related information or support that may be provided by TI. Buyer represents and agrees that it has all the necessary expertise to create and implement safeguards which anticipate dangerous consequences of failures, monitor failures and their consequences, lessen the likelihood of failures that might cause harm and take appropriate remedial actions. Buyer will fully indemnify TI and its representatives against any damages arising out of the use of any TI components in safety-critical applications.

In some cases, TI components may be promoted specifically to facilitate safety-related applications. With such components, TI's goal is to help enable customers to design and create their own end-product solutions that meet applicable functional safety standards and requirements. Nonetheless, such components are subject to these terms.

No TI components are authorized for use in FDA Class III (or similar life-critical medical equipment) unless authorized officers of the parties have executed a special agreement specifically governing such use.

Only those TI components which TI has specifically designated as military grade or "enhanced plastic" are designed and intended for use in military/aerospace applications or environments. Buyer acknowledges and agrees that any military or aerospace use of TI components which have **not** been so designated is solely at the Buyer's risk, and that Buyer is solely responsible for compliance with all legal and regulatory requirements in connection with such use.

TI has specifically designated certain components which meet ISO/TS16949 requirements, mainly for automotive use. Components which have not been so designated are neither designed nor intended for automotive use; and TI will not be responsible for any failure of such components to meet such requirements.

Products

Audio	www.ti.com/audio
Amplifiers	amplifier.ti.com
Data Converters	dataconverter.ti.com
DLP® Products	www.dlp.com
DSP	dsp.ti.com
Clocks and Timers	www.ti.com/clocks
Interface	interface.ti.com
Logic	logic.ti.com
Power Mgmt	power.ti.com
Microcontrollers	microcontroller.ti.com
RFID	www.ti-rfid.com
OMAP Mobile Processors	www.ti.com/omap
Wireless Connectivity	www.ti.com/wirelessconnectivity

Applications

Automotive and Transportation	www.ti.com/automotive
Communications and Telecom	www.ti.com/communications
Computers and Peripherals	www.ti.com/computers
Consumer Electronics	www.ti.com/consumer-apps
Energy and Lighting	www.ti.com/energy
Industrial	www.ti.com/industrial
Medical	www.ti.com/medical
Security	www.ti.com/security
Space, Avionics and Defense	www.ti.com/space-avionics-defense
Video and Imaging	www.ti.com/video

TI E2E Community e2e.ti.com