

D8M-FMC

USER MANUAL ▶▶▶

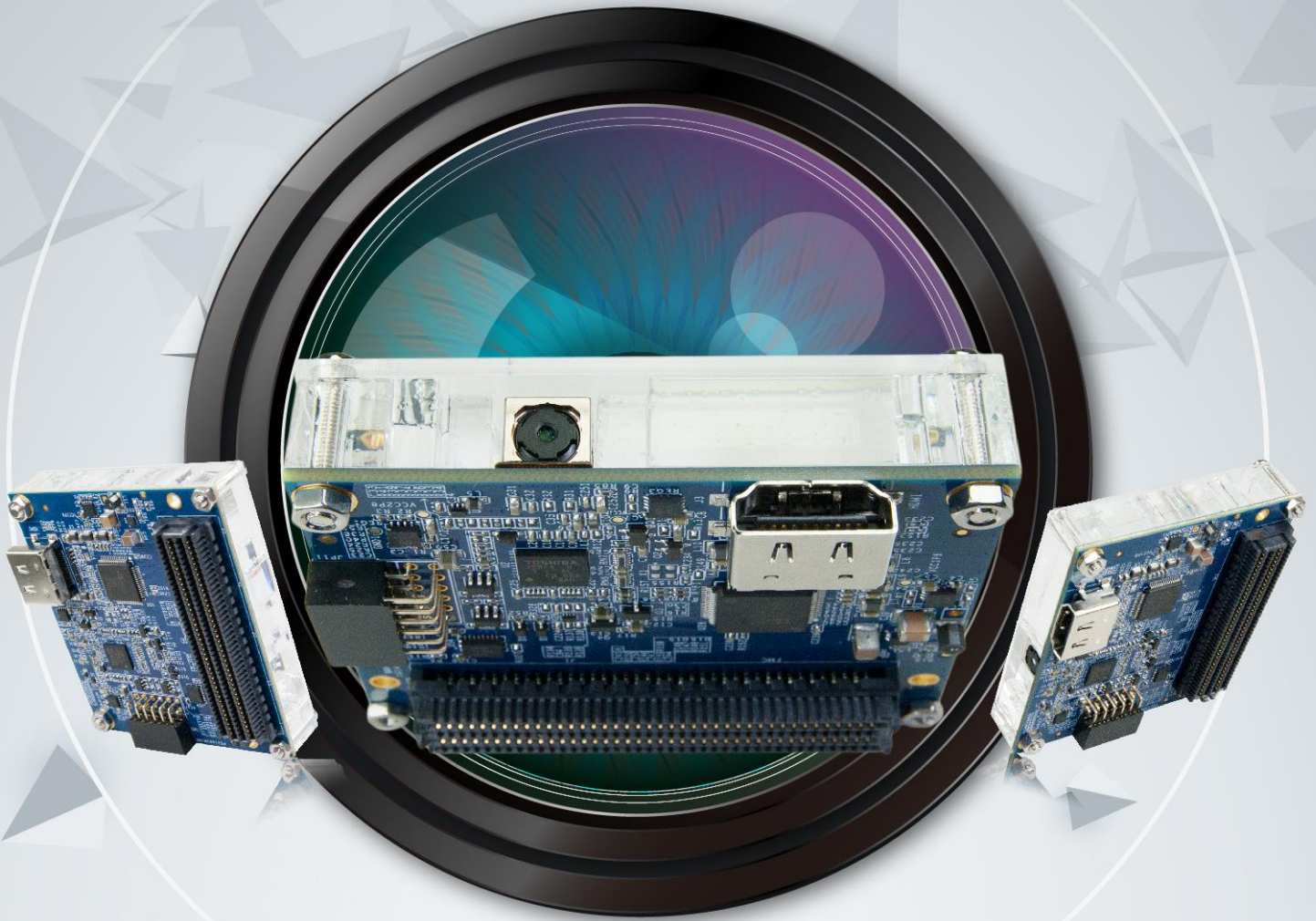

terasic
www.terasic.com

Copyright © 2003-2016 Terasic Inc. All Rights Reserved.



- Chapter 1 D8M-FMC Development Kit..... 1**
 - 1.1 Package Contents.....1
 - 1.2 D8M-FMC System CD.....2
 - 1.3 Assemble the D8M-FMC.....2
 - 1.4 Getting Help6
- Chapter 2 Introduction of the D8M-FMC Board 7**
 - 2.1 Features.....7
 - 2.2 Block Diagram of the D8M-FMC Board.....8
- Chapter 3 Using the D8M-FMC Board 9**
 - 3.1 MIPI Camera Module.....9
 - 3.2 MIPI Decoder11
 - 3.3 Clock Tree11
 - 3.4 HDMI TX Interface.....12
 - 3.5 TMD Expansion Header.....13
 - 3.6 FMC Connector14
- Chapter 4 RTL Example Codes 18**
 - 4.1 D8M-FMC RTL Demonstration Descriptions18
 - 4.2 D8M-FMC RTL Demonstration on TR520
 - 4.3 D8M-FMC RTL Demonstration on A10SoC.....23
 - 4.4 D8M-FMC RTL Demonstration on A10GFP26
- Chapter 5 NIOS Based Example Codes 29**
 - 5.1 D8M-FMC VIP Demonstration on TR5.....29
 - 5.2 D8M-FMC VIP Demonstration on Altera A10SoC34
 - 5.3 D8M-FMC VIP Demonstration on Altera A10GFP.....37
- Chapter 6 Appendix 40**
 - Revision History40
 - Copyright Statement40



Chapter 1

D8M-FMC Development Kit

Terasic D8M-FMC Board contains an 8 Mega Pixel Digital Camera and a High Performance HDMI Transmitter. The user can connect this camera module onto the FPGA development kit via the FMC (FPGA Mezzanine Card) LPC (Low Pin Count) Connectors for image capturing, image processing & image output.

The FMC connector is the standard expansion interface defined in VITA 57.1. Any main boards with a FMC connector can interface with D8M-FMC.

The D8M-FMC provides the Camera Module with high speed MIPI interface, which also supports the simple 10Bit Parallel Bayer Pattern Data solution after the MIPI Decoder conversion. It is able to control the D8M-FMC module by FPGA via I2C interface for output resolution, Frame rate, etc. The D8M-FMC also features an Auto-focus function.

The D8M-FMC also provides High Performance HDMI Transmitter via the Analog Devices ADV7513 which incorporates HDMI v1.4 features, including 3D video support, and 165 MHz supports all video formats up to 1080p and UXGA.

We provide demo source codes for the D8M-FMC working with different FPGA development kits. These demos are created by using RTL & ALTERA VIP, By referring these demos, the user can quickly learn how to work with this D8M-FMC on his/her own application.

1.1 Package Contents



The D8M-FMC package includes:

- Product Box
- System CD Download Guide
- One D8M-FMC Module
- Screw & Copper Pillar Package

Figure 1-1 The D8M-FMC package contents



1.2 D8M-FMC System CD

The D8M-FMC System CD contains all the documents and supporting materials associated with D8M-FMC, including the user manual, reference designs, and device datasheets. Users can download this system CD from the link: <http://d8m-fmc.terasic.com/cd>.

1.3 Assemble the D8M-FMC

Terasic D8M-FMC is able to connect on to any FPGA development kit that is equipped with FMC connector.

The pictures below show the connections allowing the D8M-FMC to connect to 3 different Altera/Terasic FPGA Boards:



Figure 1-2 Connect the D8M-FMC to TR5 board's expansion port

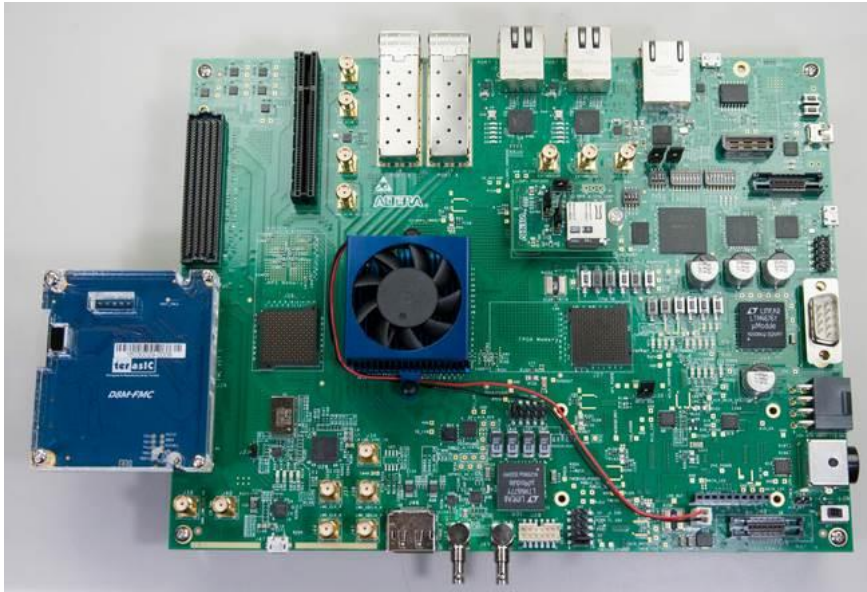

Figure 1-3 Connect the D8M-FMC to A10SoC board's expansion port



Figure 1-4 Connect the D8M-FMC to A10GFP board's expansion port

Note: The kit contains small parts, such as screws and pillars, please keep it far away from children that are under 6 years of age.

■ Installation Precautions

When installing the D8M-FMC, please follow the precautions listed below:

Turn off power: When installing, please make sure the power is turned off. Failure to turn off the power may cause severe injury to the user and/or damage the system.

Anti-static Discharge: Electronic Components like FPGA motherboards, daughter cards and other electronic components must be installed following proper grounding procedures.

It is crucial to make sure that the FMC daughter card is secured with the mounting screws.



The following steps will demonstrate how to install D8M-FMC daughter card to the FMCD port of the TR5 Board.

1. First, unpack the screws set and pillars that come with your package.



Figure 1-5 Screw & Copper Pillar Package

2. TR5 Board Mount the copper pillars and screw down, using the nuts provided, to secure the pillars on FMCD port of TR5 board.

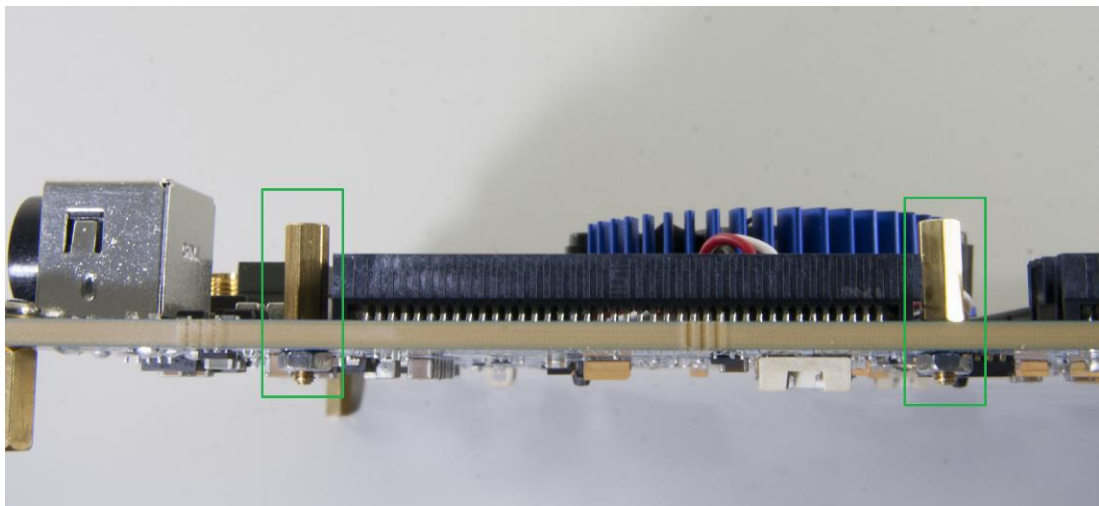

Figure 1-6 Mount the copper pillar to the TR5 Board



Install the D8M-FMC daughter card, Screw and lock down the nuts to the two pillars

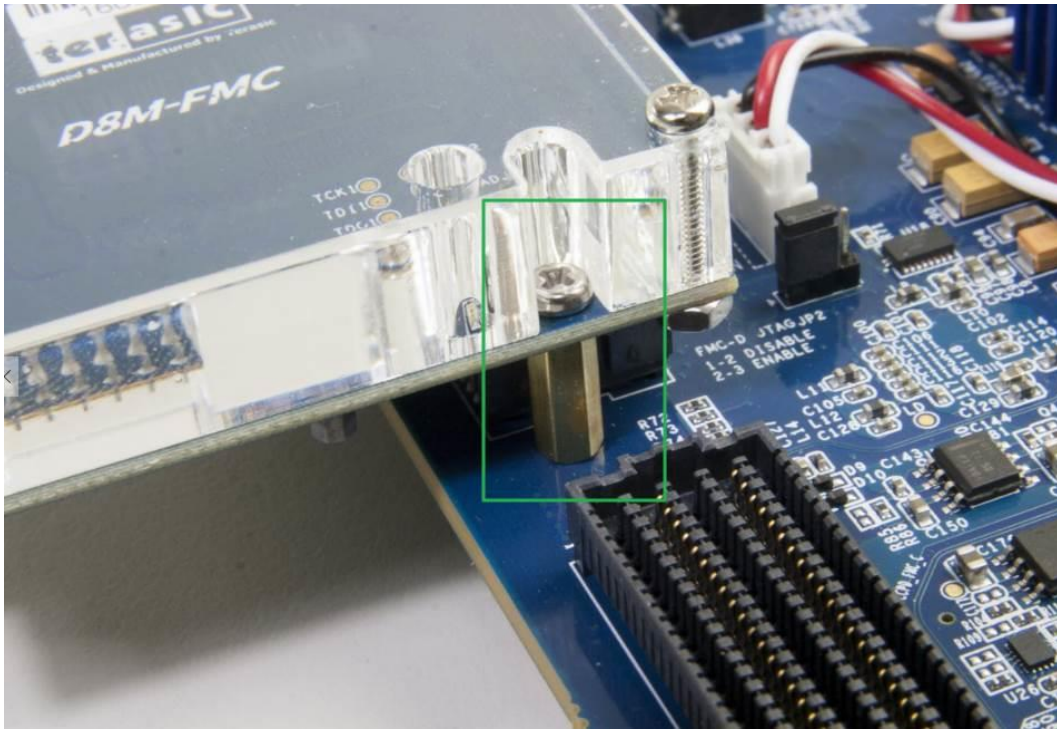

Figure 1-7 Screw the daughter card onto the pillars

3. The installation is complete.



Figure 1-8 demonstrates of how the D8M-FMC will look once installed on the TR5



1.4 Getting Help

Here are the addresses where you can get help if you encounter any problems:

Terasic Technologies

9F., No.176, Sec.2, Gongdao 5th Rd, East Dist, Hsinchu City, 30070. Taiwan

Email: support@terasic.com

Tel.: +886-3-575-0880

Website: d8m-fmc.terasic.com



Chapter 2

Introduction of the D8M-FMC Board

2.1 Features

Figure 2-1 Shows the layout of the board.

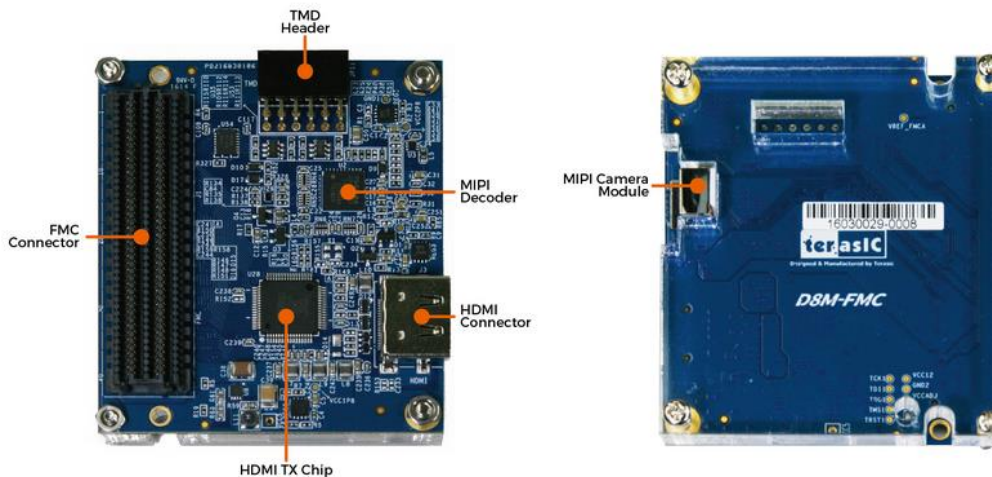

Figure 2-1 D8M-FMC Board

The D8M-FMC Board has many features that allow users to implement a wide range of designed circuits, from simple circuits to various multimedia projects.

The following hardware is provided on the board:

- Package Interface: FMC with 1.8/2.5/3.0/3.3V I/O standard.
- MIPI Camera Module:
 - Chip P/N: OV8865
 - Color Filter Arrangement: Bayer Pattern
 - View Angel: 70 °
 - Pixels: 3268x2448 (8-Mega Pixels)
 - Frame Rate:8-Mega Pixels @30fps
 - Support Focus Control
 - Programmable controls for frame rate, mirror and flip, cropping, and windowing
- MIPI Decoder:
 - Chip P/N: TC358748XBG
 - MIPI CSI-2 Compliant
 - MIPI to Parallel Port Converter



- Supports up to 4 data lanes
- HDMI TX
 - HDMI TX, compatible with DVI v1.0 and HDCP v1.4
- 2x6 Terasic Mini Digital (TMD) Expansion Header
- Package Size: 60x69 mm

2.2 Block Diagram of the D8M-FMC Board

Below **Figure 2-2** shows the D8M-FMC Block Diagram. MIPI Camera Module outputs 4 Lanes MIPI interface image data, which can be converted to Parallel data by passing through the MIPI Decoder IC to the FMC interface. A HDMI-TX for developers to display the processed video image on a monitor with HDMI input when the FPGA main board has no display capabilities. Terasic Mini Digital (TMD) is a 3.3V GPIO expansion header; Users can use these pins to expand their functions.

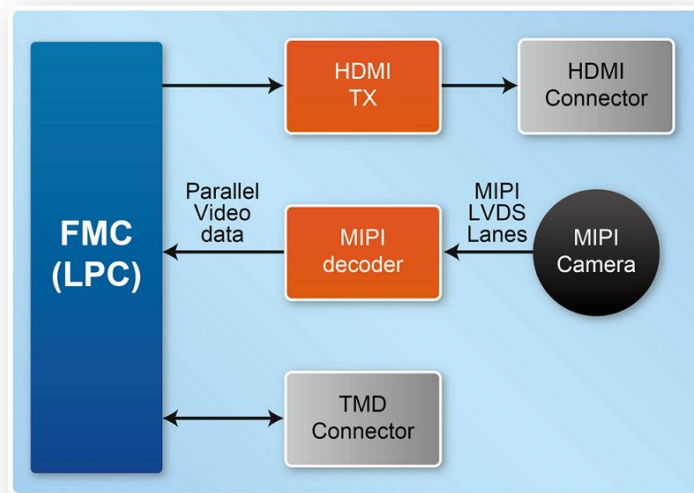

Figure 2-2 Block diagram of D8M-FMC Board



Chapter 3

Using the D8M-FMC Board

This chapter provides instructions on how to use the MIPI camera module, MIPI Decoder, HDMI-TX, TMD expansion header and FMC connector on the D8M-FMC Board.

3.1 MIPI Camera Module

- Terasic D8M-FMC Board equips with an 8M pixel MIPI camera module named OV8865 (See [Figure 3-1](#)). The OV8865 color image sensor is a high performance, 8 megapixel RAW image sensor that delivers 3264x2448. It provides options for multiple resolutions while maintaining full field of view. Users can program image resolution, frame rate, and image quality parameters. Camera functions are controlled via I2C bus (CAMERA_I2C_SDA and CAMERA_I2C_SCL). The I2C device address is 0x6C.



Figure 3-1 MIPI Camera Module

[Figure 3-2](#) Shows a cross-section of the image sensor array. The color filter is arranged in a Bayer pattern. Of the 8,332,288 pixels, 7990,272 (3264x2448) are active pixels and can be outputted. The other pixels are used for black level calibration and interpolation.

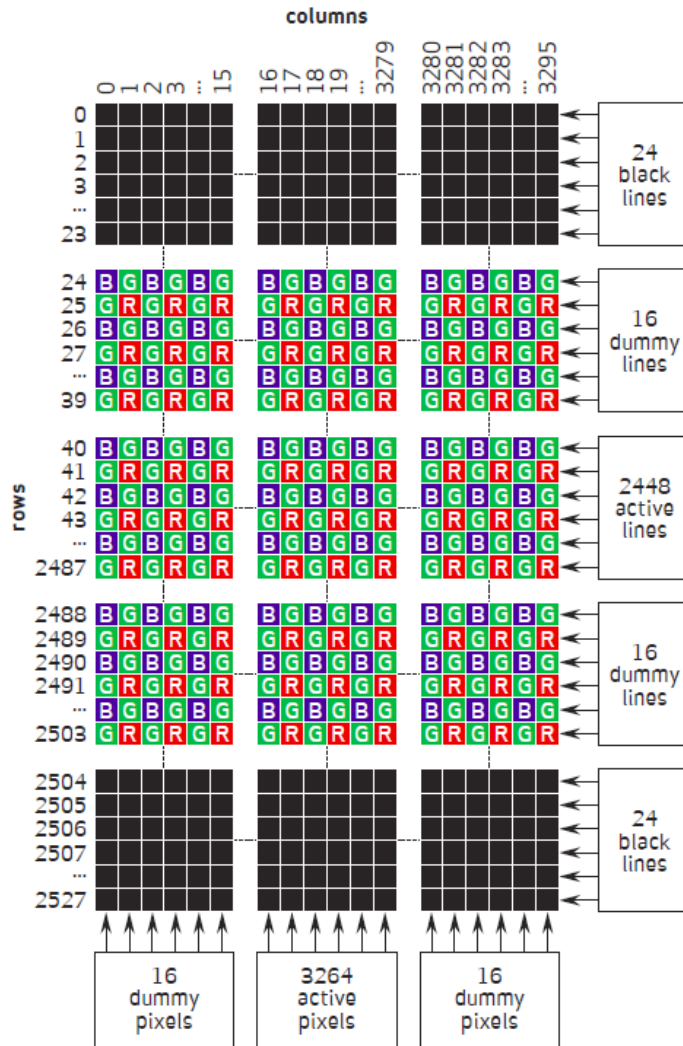

Figure 3-2 Sensor Array Region color filter Layout (From Camera Datasheet)

For more hardware description and register information about this camera module, please refer to the datasheet named OV8865 Data Sheet.pdf in the D8M-FMC System CD.

In addition, there is a Voice Coil Motor (VCM) driver chip named VM149C on the MIPI camera module. Users can use the same I2C bus (I2C device address is 0x18) to modify the DAC value in the VCM driver chip that can allow the VCM to move its lens to the desired position for getting a sharp image and realizing the Auto Focus (AF) feature. Terasic also provides an AF demonstration and IP in the System CD. See section 4.x for details. The datasheet of this VCM driver IC named VM149C VCM Driver IC.pdf also can be found in the System CD.



3.2 MIPI Decoder

The MIPI camera module output interface is MIPI interface, which can not directly connect to the Terasic FPGA board; therefore, a MIPI Decoder (TC358748XBG) is added to convert MIPI interface to a parallel port interface (See **Figure 3-3**). With the Decoder users can quickly obtain the image data and process it. MIPI Decoder can convert MIPI Interface up to 24-bit data. The Camera module used onto on the D8M-FMC can only output 10 bit data, MIPI_PIXEL_D[9:0] on the FMC connector is the camera image output data bus.

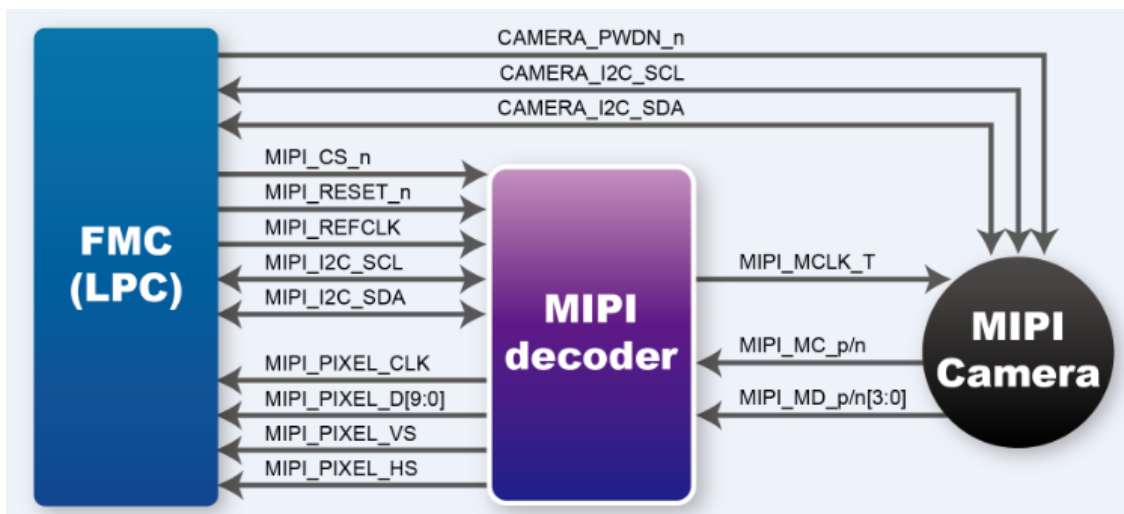

Figure 3-3 System Overview with MIPI Decoder in CSI-2 RX to Parallel Port Configuration

FPGA also can configure MIPI Decoder through a I2C bus (MIPI_I2C_SDA / MIPI_I2C_SCL; I2C device address is 0x1C), which is different from the camera module I2C bus. On the D8M-FMC Board, MIPI Decoder can output clocks to the MIPI camera and FPGA board. So in the demonstrations, most of them show how to control IC PLL parameters as well as others. You can refer to section 3-3 clock tree for details.

3.3 Clock Tree

Figure 3-4 is the D8M-FMC Board camera part's clock tree block diagram. MIPI Decoder PLL receives FPGA Reference Clock (MIPI_REFCLK) and outputs Clock to Camera sensor (MCLK), at the same time, MIPI Decoder PLL will also output a parallel port clock (MIPI_PIXEL_CLK) and feedback to the FPGA to deal with parallel data.

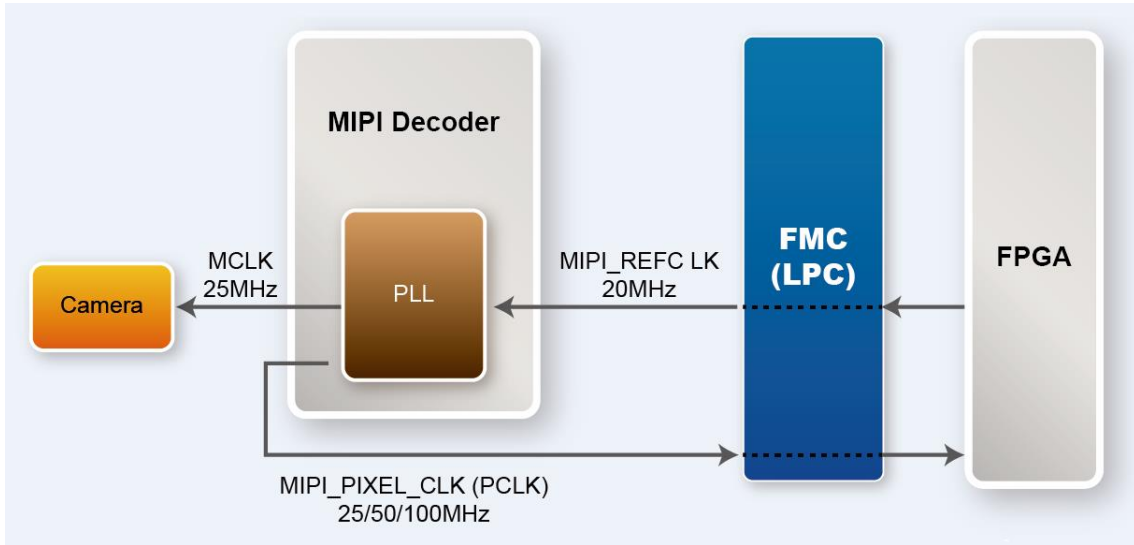

Figure 3-4 Simple Clock Tree of Camera part on D8M-FMC Board

In the provided demonstrations, MIPI_REFCLK is set to 20MHz; FPGA transmits this clock to the D8M-FMC MIPI Decoder PLL through the FMC connector. No matter how much the camera resolution is, the MCLK fixed output is 25MHz. According to the output resolution, MIPI_PIXEL_CLK can be set as 25MHz for 640x480@60fps and 100MHz for 1920x1080@30fps.

For more MIPI Decoder PLL setting details, please refer to TC358746AXBG_748XBG_rev09.pdf "Chapter 5: Clock and System" or refer to Terasic demonstrations.

3.4 HDMI TX Interface

The development board provides High Performance HDMI Transmitter via the Analog Devices ADV7513 which incorporates HDMI v1.4 features, including 3D video support, and 165 MHz supports all video formats up to 1080p and UXGA. The ADV7513 is controlled via a serial I2C bus interface, which is connected to pins on the FMC Connector.

Figure 3-5 Shows the connections of FMC LPC connector and HDMI TX chip.

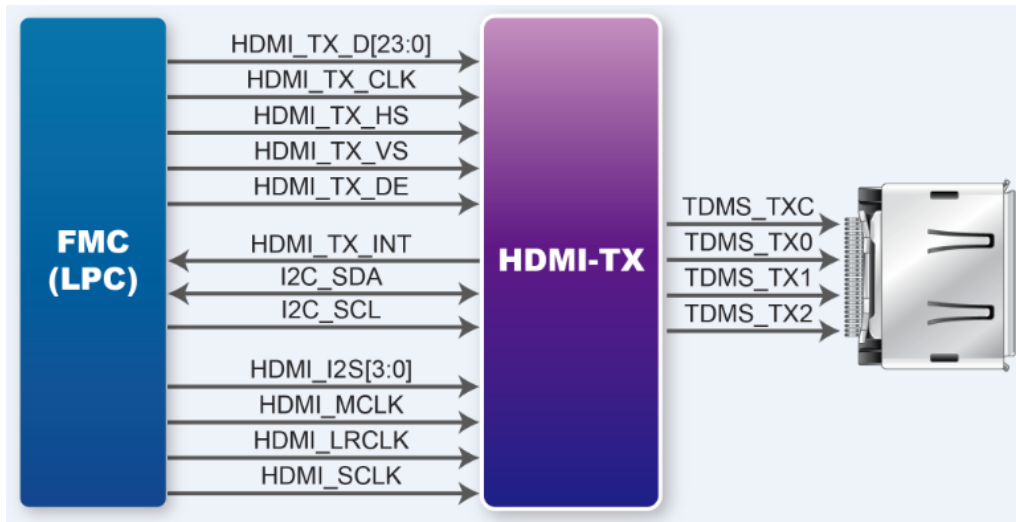

Figure 3-5 Connections between the FMC and HDMI Transmitter Chip

3.5 TMD Expansion Header

The development board provides a TMD (Terasic Mini Digital) expansion header, and pins of the interface are shifted to 3.3V IO standard by a Level Shift. Users can use this TMD interface to extend their own designs, and please make sure TMD_D [7:0] are general purpose IOs on the main board.

Figure 3-6 Shows the connections between FMC LPC connector and TMD expansion header.

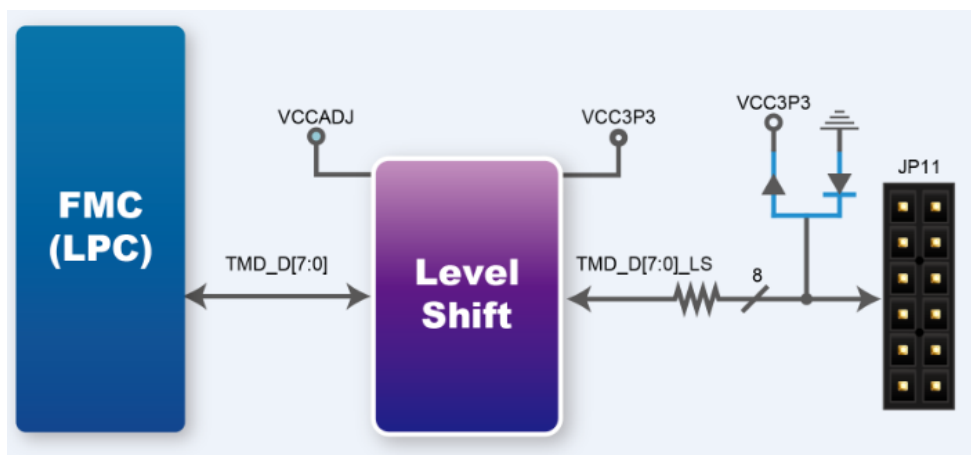

Figure 3-6 Connections between the FMC and TMD expansion header



3.6 FMC Connector

Figure 3-7, Figure 3-8 and Table 3-1 Shows the pin out and pin definitions of the FMC LPC connector.

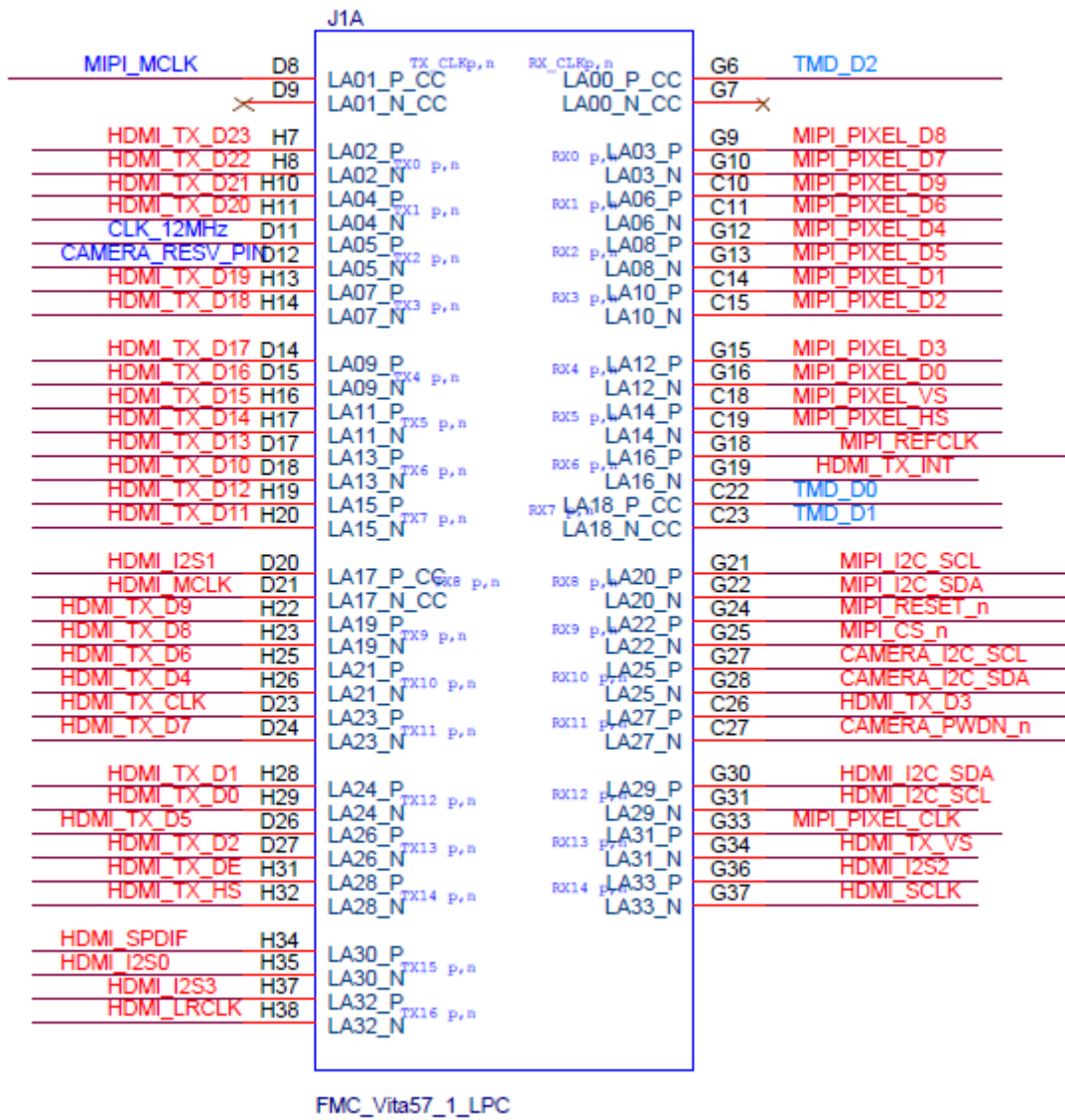

Figure 3-7 Pin-out of the FMC LPC connector on D8M-FMC (1)

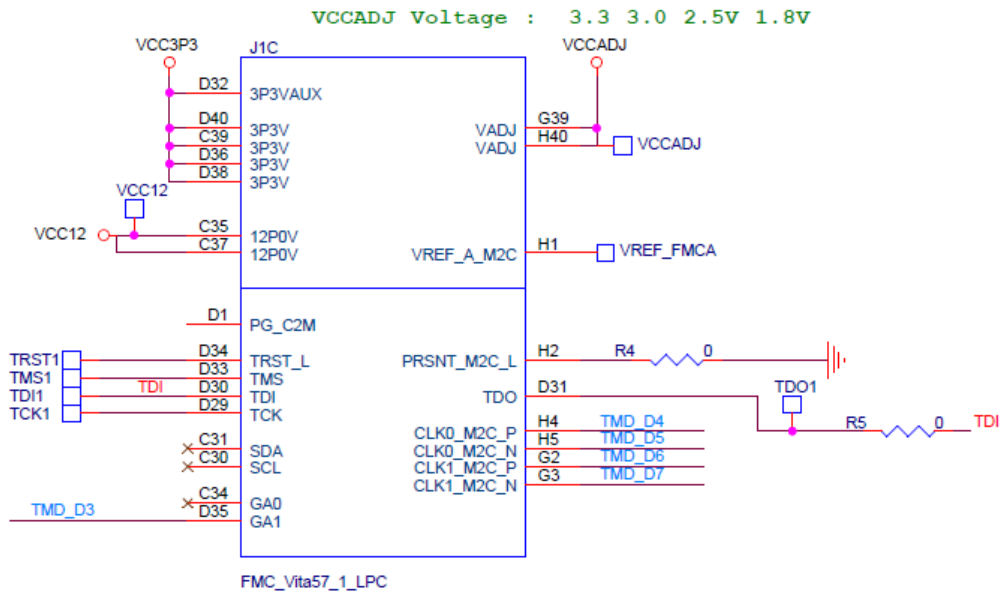

Figure 3-8 Pin-out of the FMC LPC connector on D8M-FMC (2)

Table 3-1 Pin Assignment of D8M-FMC FMC Interface

Signal Name	Connector Pin No.	Description	Pin Direction	I/O Standard
CAMERA_I2C_SCL	G27	I2C Clock for MIPI camera	inout	VCCADJ
CAMERA_I2C_SDA	G28	I2C Data for MIPI camera	inout	VCCADJ
CAMERA_PWDN_n	C27	Power Down signal of MIPI camera	output	VCCADJ
CAMERA_RESV_PIN	D12	Reserve	output	VCCADJ
MIPI_CS_n	G25	Chip Select	output	VCCADJ
MIPI_I2C_SCL	G21	I2C Clock for bridge device	inout	VCCADJ
MIPI_I2C_SDA	G22	I2C Data for bridge device	inout	VCCADJ
MIPI_MCLK	D8	Reserve	output	VCCADJ
MIPI_PIXEL_CLK	G33	Parallel Port Clock signal	input	VCCADJ
MIPI_PIXEL_D[0]	G16	Parallel Port Data	input	VCCADJ
MIPI_PIXEL_D[1]	C14	Parallel Port Data	input	VCCADJ
MIPI_PIXEL_D[2]	C15	Parallel Port Data	input	VCCADJ
MIPI_PIXEL_D[3]	G15	Parallel Port Data	input	VCCADJ
MIPI_PIXEL_D[4]	G12	Parallel Port Data	input	VCCADJ
MIPI_PIXEL_D[5]	G13	Parallel Port Data	input	VCCADJ
MIPI_PIXEL_D[6]	C11	Parallel Port Data	input	VCCADJ
MIPI_PIXEL_D[7]	G10	Parallel Port Data	input	VCCADJ
MIPI_PIXEL_D[8]	G9	Parallel Port Data	input	VCCADJ
MIPI_PIXEL_D[9]	C10	Parallel Port Data	input	VCCADJ
MIPI_PIXEL_HS	C19	Parallel Port Horizontal Synchronization signal	input	VCCADJ



MIPI_PIXEL_VS	C18	Parallel Port Vertical Synchronization signal	input	VCCADJ
MIPI_REFCLK	G18	Reference Clock Input of bridge device	output	VCCADJ
MIPI_RESET_n	G24	Master Reset signal for MIPI camera and bridge device	output	VCCADJ
HDMI_I2C_SCL	G31	HDMI I2C Clock	inout	VCCADJ
HDMI_I2C_SDA	G30	HDMI I2C Data	inout	VCCADJ
HDMI_I2S[0]	H35	I2S Channel 0 Audio Data Input	output	VCCADJ
HDMI_I2S[1]	D20	I2S Channel 1 Audio Data Input	output	VCCADJ
HDMI_I2S[2]	G36	I2S Channel 2 Audio Data Input	output	VCCADJ
HDMI_I2S[3]	H37	I2S Channel 3 Audio Data Input	output	VCCADJ
HDMI_LRCLK	H38	Left/Right Channel Signal Input	output	VCCADJ
HDMI_MCLK	D21	Audio Reference Clock Input	output	VCCADJ
HDMI_SCLK	G37	I2S Audio Clock Input	output	VCCADJ
HDMI_SPDIF	H34	S/PDIF Audio Input.	output	VCCADJ
HDMI_TX_CLK	D23	Video Clock	output	VCCADJ
HDMI_TX_D[0]	H29	Video Data bus	output	VCCADJ
HDMI_TX_D[1]	H28	Video Data bus	output	VCCADJ
HDMI_TX_D[2]	D27	Video Data bus	output	VCCADJ
HDMI_TX_D[3]	C26	Video Data bus	output	VCCADJ
HDMI_TX_D[4]	H26	Video Data bus	output	VCCADJ
HDMI_TX_D[5]	D26	Video Data bus	output	VCCADJ
HDMI_TX_D[6]	H25	Video Data bus	output	VCCADJ
HDMI_TX_D[7]	D24	Video Data bus	output	VCCADJ
HDMI_TX_D[8]	H23	Video Data bus	output	VCCADJ
HDMI_TX_D[9]	H22	Video Data bus	output	VCCADJ
HDMI_TX_D[10]	D18	Video Data bus	output	VCCADJ
HDMI_TX_D[11]	H20	Video Data bus	output	VCCADJ
HDMI_TX_D[12]	H19	Video Data bus	output	VCCADJ
HDMI_TX_D[13]	D17	Video Data bus	output	VCCADJ
HDMI_TX_D[14]	H17	Video Data bus	output	VCCADJ
HDMI_TX_D[15]	H16	Video Data bus	output	VCCADJ
HDMI_TX_D[16]	D15	Video Data bus	output	VCCADJ
HDMI_TX_D[17]	D14	Video Data bus	output	VCCADJ
HDMI_TX_D[18]	H14	Video Data bus	output	VCCADJ
HDMI_TX_D[19]	H13	Video Data bus	output	VCCADJ
HDMI_TX_D[20]	H11	Video Data bus	output	VCCADJ
HDMI_TX_D[21]	H10	Video Data bus	output	VCCADJ
HDMI_TX_D[22]	H8	Video Data bus	output	VCCADJ
HDMI_TX_D[23]	H7	Video Data bus	output	VCCADJ



HDMI_TX_DE	H31	Data Enable Signal for Digital Video.	output	VCCADJ
HDMI_TX_HS	H32	Horizontal Synchronization	output	VCCADJ
HDMI_TX_INT	G19	Interrupt Signal	input	VCCADJ
HDMI_TX_VS	G34	Vertical Synchronization	output	VCCADJ
CLK_12MHZ	D11	Reserve	output	VCCADJ
TMD_D[0]	C22	Terasic Mini Digital Data 0	inout	VCCADJ
TMD_D[1]	C23	Terasic Mini Digital Data 1	inout	VCCADJ
TMD_D[2]	G6	Terasic Mini Digital Data 2	inout	VCCADJ
TMD_D[3]	D35	Terasic Mini Digital Data 3	inout	VCCADJ
TMD_D[4]	H4	Terasic Mini Digital Data 4	inout	VCCADJ
TMD_D[5]	H5	Terasic Mini Digital Data 5	inout	VCCADJ
TMD_D[6]	G2	Terasic Mini Digital Data 6	inout	VCCADJ
TMD_D[7]	G3	Terasic Mini Digital Data 7	inout	VCCADJ



Chapter 4

RTL Example Codes

This chapter provides instructions on how to capture a D8M-FMC image (resolution is 720P@60 Hz) and use on-chip-ram storage methods to display the image on a HDMI Monitor. The storage methods realized by pure Verilog HDL language have been validated on TR5, A10SoC and A10GFP board.

4.1 D8M-FMC RTL Demonstration Descriptions

This section provides instructions on how to store Camera capturing image (720P@60Hz) in a larger on-chip memory(Frame-Buffer), this Memory is expect to store up to one Frame image, and how to extract Frame-Buffer address data to convert RAW data to RGB data, and output the RGB data to LCD with 720P@60 Hz timing.

■ Function Block Diagram

Figure 4-1 Shows the Function block diagram of Camera demonstration. This design block is one dual-port-ram Control module can control on chip Memory and read/write image data. Camera raw data will be written in on-chip-ram first. After finishing writing a Frame, ON-CHIP_FRAM module will read out the data from dual-port-ram to RAW2RGB_J module to convert RAW data to RGB data. The RGB data will output along with the signal timing generated by VGA_Controller to LCD. In the block, other module (for example, FOCUS_ADJ, MIPI_BRIDGE_CAMERA_Config) function instructions and BUTTON/SW operation. All module functions are described below:

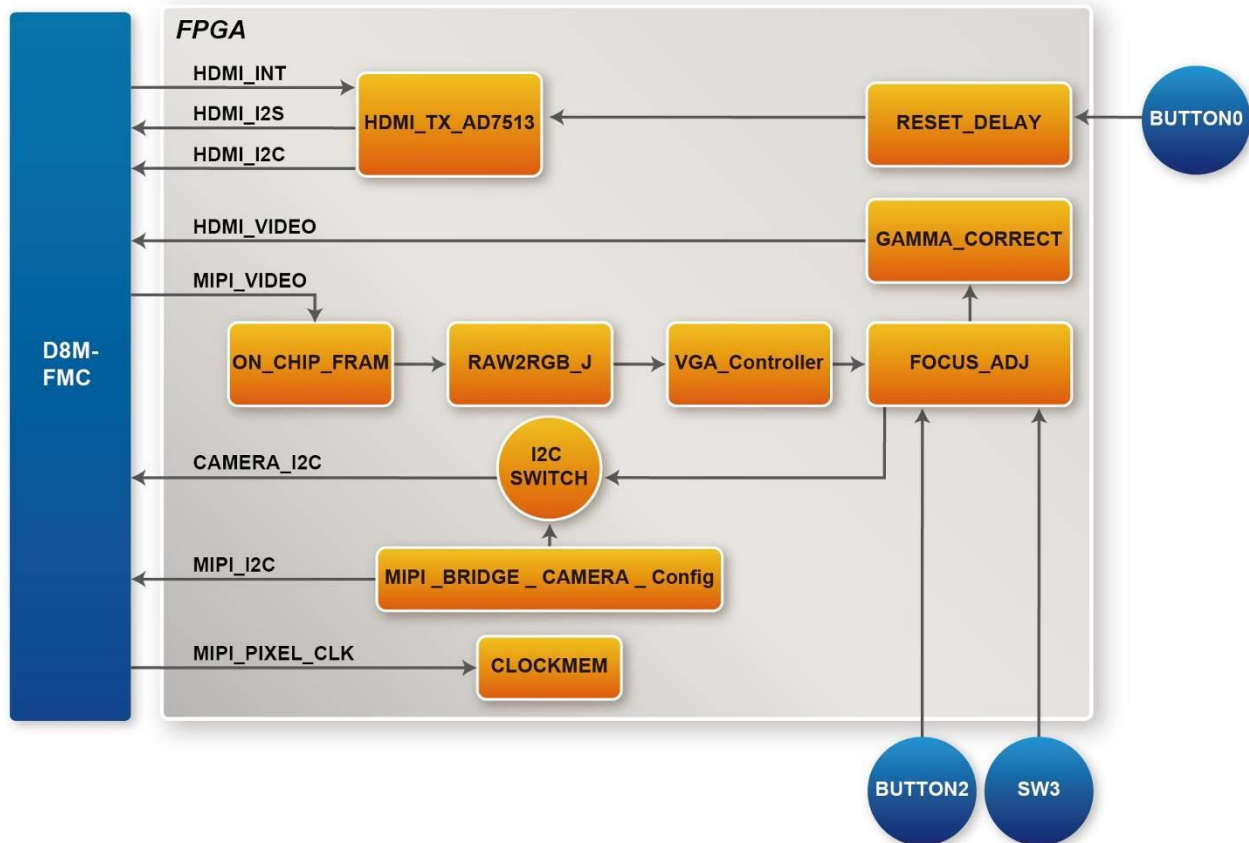

Figure 4-1 Block diagram of the digital camera D8M-FMC design with on-chip memory

RESET_DELAY: When press BUTTON0 , this module will provide LOW signal of about 0.25 seconds for the whole system module to do RESET.

ON_CHIP_FRAM :This module is one dual-port-ram controller can control 1280 x 720 x10bit on-chip ram and read/write image data

MIPI_BRIDGE_CAMERA_Config :the MIPI BRIDGE I2C and Camera I2C setting controller, such as set to output 720P@60Hz timing. It mainly writes I2C corresponding parameters to MIPI-BRIDGE IC register and Camera Sensor IC register respectively through their own I2C buses. MIPI_I2C bus is used to write MIPI BRIDGE I2C (I2C Slave Address = 0x1c.), CAMERA_I2C bus is used to write Camera Sensor (IC Slave Address = 0x6c).

RAW2RGB_J : This module is to convert RAW data to RGB data.

VGA_Controller: the LCD signal timing generator, can generate 720P@60 Hz signal timing.

FOCUS_ADJ: This module provides two main functions.

The first function is using I2C bus to write D8M Voice Coil Motor (VCM) driver IC register, and control the camera lens' movements to perform image focusing. VCM driver IC register (I2C Slave Address =0x18) shares I2C bus with camera module. The other function is doing the current image high frequency component statistic. When the VCM drives the camera lens' movement, a real-time statistics of image high-frequency sum will be done in every step of the moving. Finally, the lens will move to a position which has the largest number of high frequency to complete the automatic focus operation.



Focus area can be selected by SW3. There are two options :

- (1). Select focusing the whole screen area (set SW3 to 0)
- (2). Select focusing the middle area (set SW3 to 1).

Once you set SW3 to a value (0 or 1) and press BUTTON2 one time, the automatic focus operation will be performed in the selected area.

GAMMA_CORRECT: by Bézier Curve in real time (none LUT-TABLE) produce GAMMA curve generate new RGB's data.

HDMI_TX_AD7513: This module will setting AD7513 (HDMI TX) I2C setting controller, set register respectively through own I2C buses. (I2C Slave Address = 0x72), and 1 KHz sine wave by I2S bus send to AD7513 output sound.

CLOCKMEM: This module will divide MIPI_PIXEL_CLK (100MHz) to 1Hz to display on LEDs.

We provide the demonstrations on TR5, A10SoC and A10GFP. The section SWITCH setting and BUTTON operation are the same on TR5, A10SoC and A10GFP. The following are the descriptions of the three platforms' set up, as well as the test steps.

4.2 D8M-FMC RTL Demonstration on TR5

■ Hardware Setting Up

- As shown in [Figure 4-2](#)

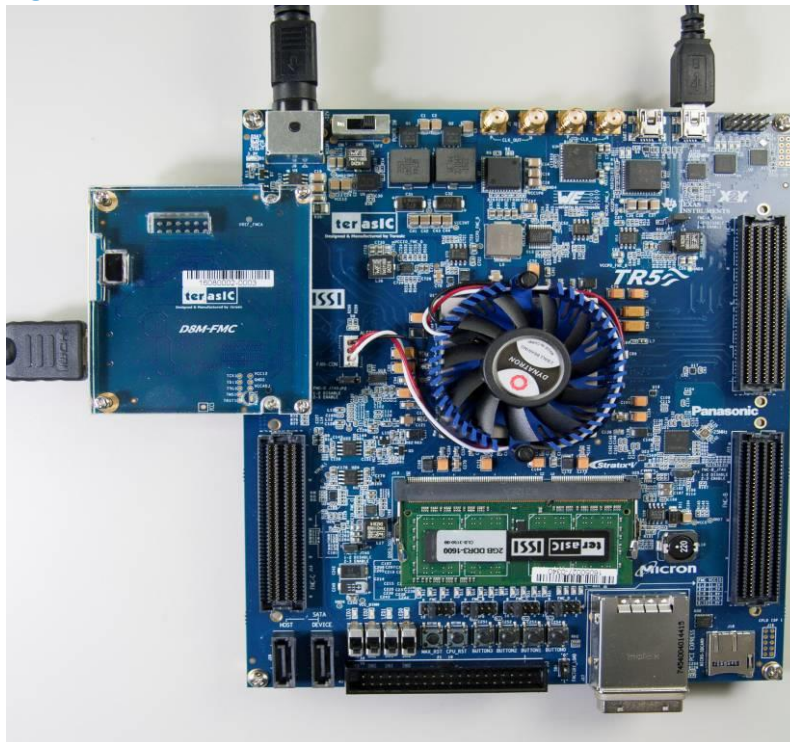

Figure 4-2 TR5 demo hardware setting up



■ Design Tools

- Quartus II v16.0

■ Demonstration Source Code

- Quartus project directory: TR5_D8M_FMC_RTL
- Bitstream used: D8M_FMC.sof

■ Demonstration Batch File

- Demo batch file folder: demonstrations\TR5_D8M_FMC_RTL\demo_batch

■ Demonstration Setup

- Connect the TR5 (J6) to the host PC with a USB cable and install the USB-Blaster II driver if necessary.
- Plug D8M-FMC onto TR5 FMC_D(J10), connect HDMI monitor to HDMI port see [Figure 4-2](#).
- Plug the 12V adapter to TR5 Board.
- Make sure the VADJ of FMC_D is set to 2.5V by placing a jumper between JP9.7 and JP9.8, as shown in [Figure 4-4](#)
- Power on the TR5 board.
- Execute the demo batch file “test.bat” from the directory\TR5_D8M_FMC_RTL\demo_batch.
- LED0~1 light up, stand the settings of D8M-FMC MIPI decoder IC and Camera Sensor I2C are completed..
- LED2 when plug HDMI monitor cable generates an interrupt signal. LED2 will extinguish, and after bright.
- LED3 blink in 1Hz, stand MIPI_PIXEL_CLK are generated correctly.
- D8M-FMC capturing image displays on HDMI monitor, if the HDMI monitor image is fuzzy, please press BUTTON2 one time again (will perform the focus operation again). Users can switch SW3 to “1” (there will be a yellow box on image), then, press BUTTON2 one time again, the middle area focus operation will be performed.
- This demonstration also simply demonstrates the HDMI-Audio function ,it will produce a 1K sine wave voice when pressing BUTTON3.
- [Table 4-1](#) Summarizes the functional keys and details of each LED status.

Table 4-1 The functional keys of the TR5 digital camera demonstration

Name	Description
LED0	Lights up when MIPI DECODER I2C setting is successful
LED1	Lights up when CAMERA I2C setting is successful
LED2	When HDMI cable plug , LED Blink (blinking)
LED3	Blink in 1HZ (D8M-FMC PIXE CLOCK /100M)
BUTTON0	SYSTEM RESET
BUTTON2	Image auto focus(area based on SW3 selection)
SW3	0: No yellow box (focus on whole screen area) 1: There is a yellow box(focus on yellow box)



- **Figure 4-3** Shows the locations of buttons/switches/LEDs on TR5 board.

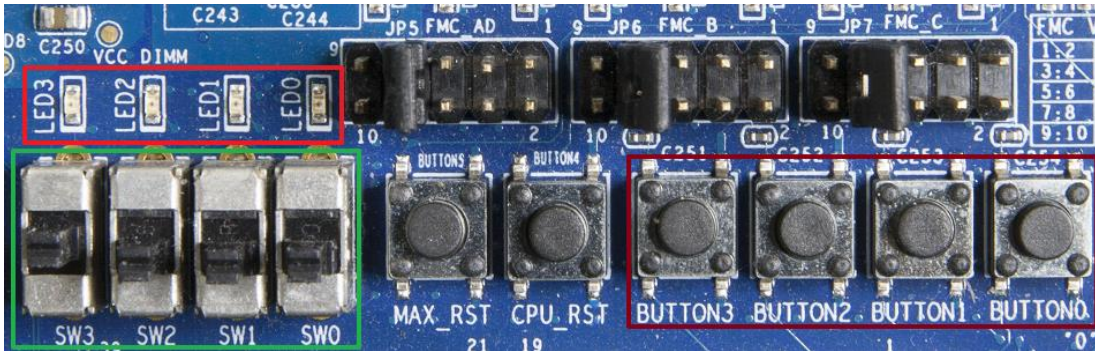

Figure 4-3 Buttons/Switches/LEDs on TR5 Board



Figure 4-4 Adjust FMC_D VADJ to 2.5V by short JP9.7 and JP9.8



4.3 D8M-FMC RTL Demonstration on A10SoC

■ Hardware Setting Up

As shown in [Figure 4-5](#)

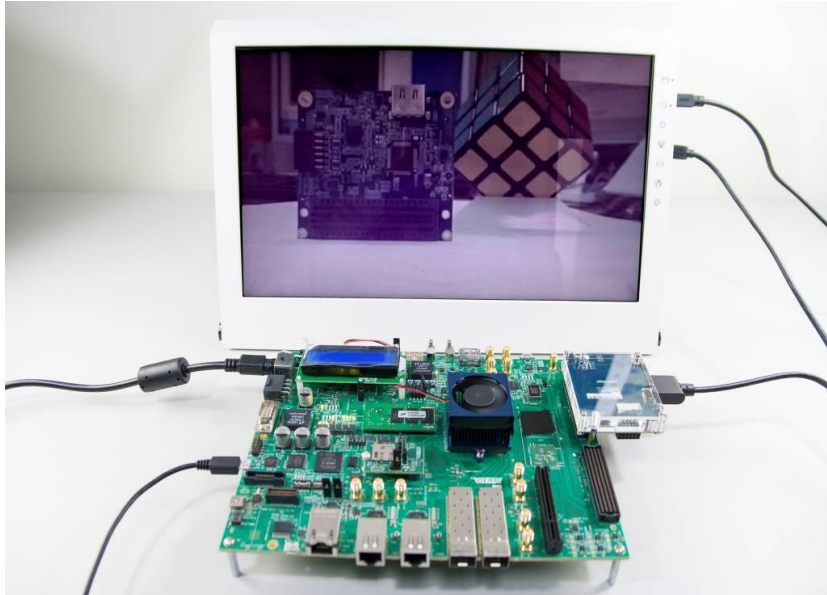

Figure 4-5A10SoC demo hardware setting up

■ Design Tools

- Quartus II v16.0

■ Demonstration Source Code

- Quartus project directory: A10SOC_D8M_FMC_RTL
- Bitstream used: A10SOC_D8M_FMC_RTL.sof

■ Demonstration Batch File

- Demo batch file folder: Demonstrations\A10SOC_D8M_FMC_RTL\demo_batch

■ Demonstration Setup

- Connect the A10SoC board (J22) to the host PC with a USB cable and install the USB-Blaster II driver if necessary.
- Plug D8M-FMC onto A10SoC (FMC Port A), connect HDMI monitor to HDMI port see [Figure 4-5](#)
- Plug the 12V adapter to A10SoC Board.
- Make sure the FMC_A's VADJ is set to 1.8V by short J42.9 and J42.10 as shown in [Figure 4-8](#)
- Power on the A10SoC board.
- Execute the demo batch file “test.bat” from the directory\
A10SOC_D8M_FMC_RTL\demo_batch.



- USER_LED_FPGA0~1 light up, stand the settings of D8M-FMC MIPI decoder IC and Camera Sensor I2C are completed..
- USER_LED_FPGA2 when plug HDMI monitor cable generates an interrupt signal. USER_LED_FPGA2 will extinguish, and after bright.
- USER_LED_FPGA3 blink in 1Hz, stand MIPI_PIXEL_CLK are generated correctly.
- D8M-FMC capturing image displays on HDMI monitor, if the HDMI monitor image is fuzzy, please press USER_PB_FPGA2 one time again (will perform the focus operation again). Users can switch USER_DIPSW_FPGA3 to “1” (there will be a yellow box on image), then, press USER_PB_FPGA2 one time again, the middle area focus operation will be performed.
- This demonstration also simply demonstrates the HDMI-Audio function ,it will produce a 1K sine wave voice when pressing USER_PB_FPGA2.
- **Table 4-2** Summarizes the functional keys and details of each LED status.

Table 4-2 The functional keys of the A10SoC digital camera demonstration

Name	Description
USER_LED_FPGA0(D26)	Lights up when MIPI DECODER I2C setting is successful
USER_LED_FPGA1(D25)	Lights up when CAMERA I2C setting is successful
USER_LED_FPGA2(D28)	When HDMI cable plug , LED Blink (blanking)
USER_LED_FPGA3(D27)	Blink in 1HZ (D8M-FMC PIXE CLOCK /100M)
USER_PB_FPGA0(PB0)	SYSTEM RESET
USER_PB_FPGA2(PB2)	Image auto focus(area based on DIPSW_FPGA3 selection)
USER_DIPSW_FPGA3(SW2.8)	0: No yellow box (focus on whole screen area) 1: There is a yellow box(focus on yellow box)

- **Figure 4-6** and **Figure 4-7** Show the locations of buttons/switches/LEDs on A10SoC board:

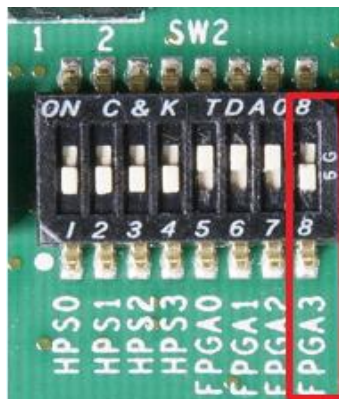

Figure 4-6 USER_DIPSW_FPGA3 location on A10SoC board

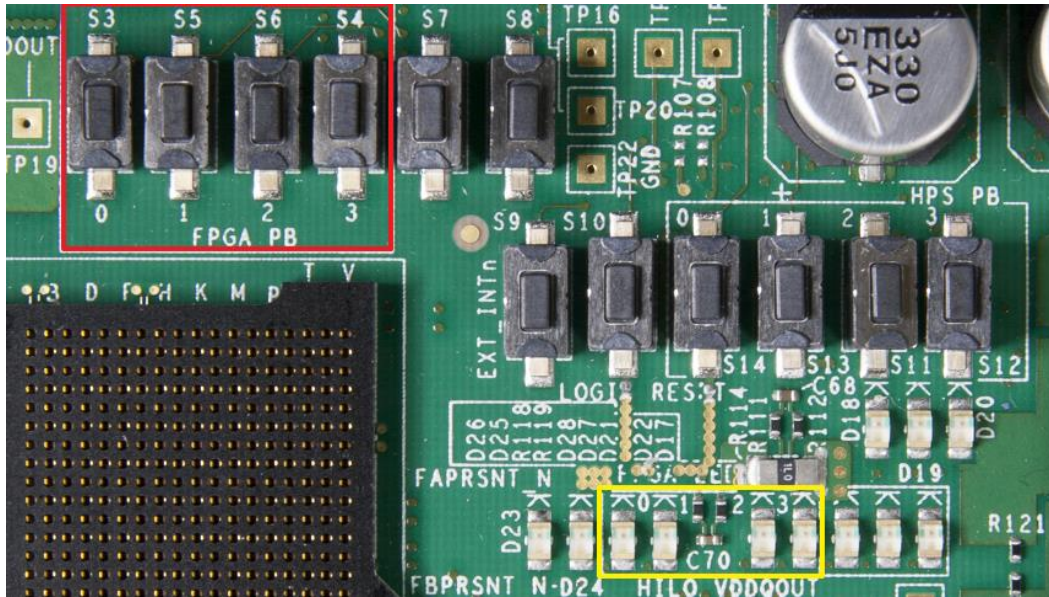

Figure 4-7 USER_PB_FPGA/USER_LED_FPGA locations on A10SoC board

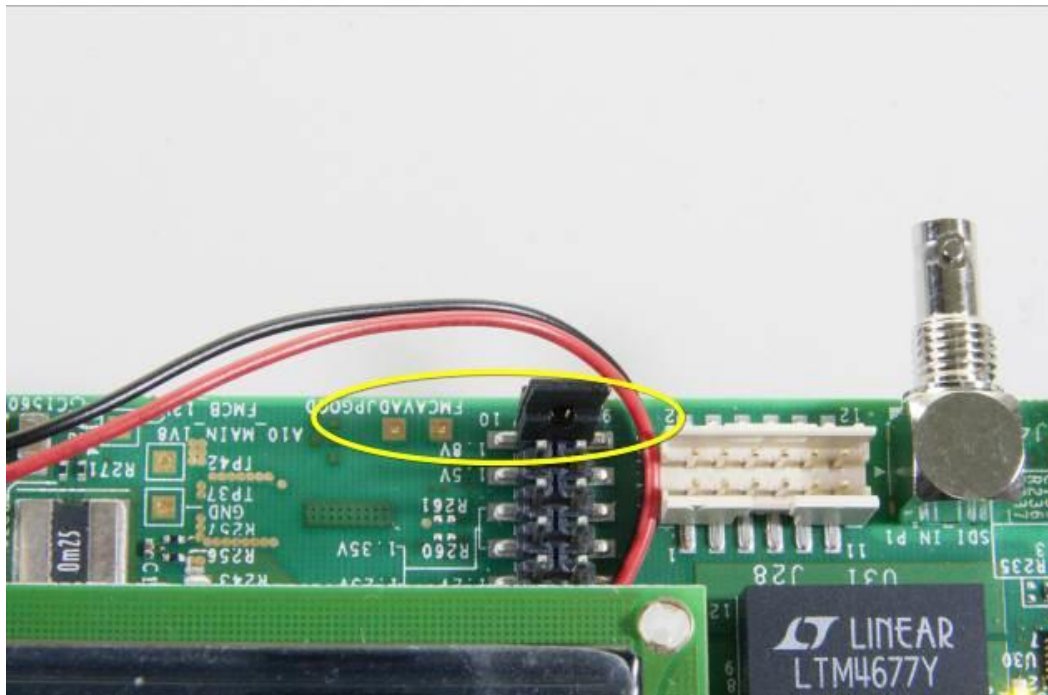

Figure 4-8 Adjust FMC_A VADJ to 1.8V by short J42.9 and J42.10



4.4 D8M-FMC RTL Demonstration on A10GFP

■ Hardware Setting Up

As shown in [Figure 4-9](#)

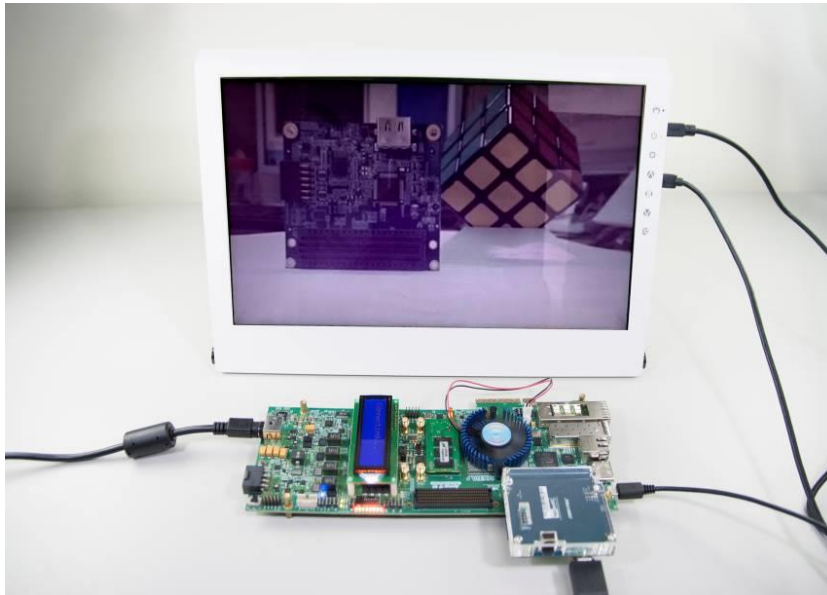

Figure 4-9 A10GFP demo hardware setting up

■ Design Tools

- Quartus II v16.0

■ Demonstration Source Code

- Quartus project directory: A10GFP_D8M_FMC_RTL.
- Bitstream used: A10GFP_D8M_FMC_RTL.sof.

■ Demonstration Batch File

- Demo batch file folder: Demonstrations\A10GFP_D8M_FMC_RTL\demo_batch

■ Demonstration Setup

- Connect the A10GFP board (J3) to the host PC with a USB cable and install the USB-Blaster II driver if necessary
- Plug D8M-FMC onto A10GFP (FMC Port A), connect HDMI monitor to HDMI port of D8M-FMC see [Figure 4-9](#).
- Plug the 12V adapter to A10GFP Board.
- Make sure the FMC_A's VADJ is set to 1.8V by short R1086 as shown in [Figure 4-11](#).(The A10GFP version is Rev E3.1)
- Power on the A10GFP board.
- Execute the demo batch file "test.bat" from the directory\



A10GFP_D8M_FMC_RTL\demo_batch.

- USER_LED_R0~1 light up, stand the settings of D8M-FMC MIPI decoder IC and Camera Sensor I2C are completed..
- USER_LED_R2 when plug HDMI monitor cable generates an interrupt signal. USER_LED_R2 will extinguish, and after bright.
- USER_LED_R3 blink in 1Hz, stand MIPI_PIXEL_CLK are generated correctly.
- D8M-FMC capturing image displays on HDMI monitor, if the HDMI monitor image is fuzzy, please press USER_PB2 one time again (will perform the focus operation again). Users can switch USER_DIPSW3 to “1” (there will be a yellow box on image), then, press USER_PB2 one time again, the middle area focus operation will be performed.
- This demonstration also simply demonstrates the HDMI-Audio function ,it will produce a 1K sine wave voice when pressing USER_PB2.
- **Table 4-3** Summarizes the functional keys and details of each LED status.

Table 4-3 The functional keys of the A10GFP digital camera demonstration

Name	Description
USER_LED_R0 (D10)	Lights up when MIPI DECODER I2C setting is successful
USER_LED_R1 (D9)	Lights up when CAMERA I2C setting is successful
USER_LED_R2 (D8)	When HDMI cable plug , LED Blink (blinking)
USER_LED_R3 (D7)	Blink in 1HZ (D8M-FMC PIXE CLOCK /100M)
USER_PB0 (PB0)	SYSTEM RESET
USER_PB2 (PB2)	Image auto focus(area based on USER_DIPSW3 selection)
USER_DIPSW3(SW2.4)	0: No yellow box (focus on whole screen area) 1: There is a yellow box(focus on yellow box)

- **Figure 4-10** Shows the locations of buttons/switches/LEDs on A10GFP board:

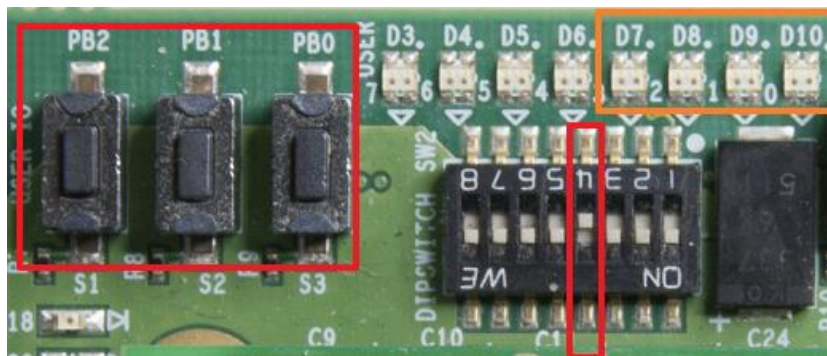

Figure 4-10 USER PBs/DIPSWs/LEDs locations on A10GFP board

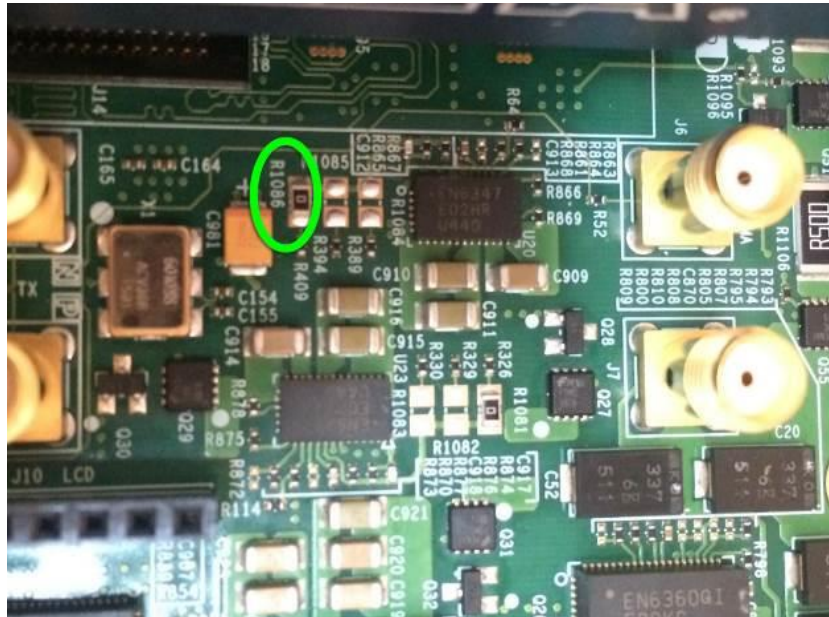

Figure 4-11 Adjust FMC_A VADJ to 1.8V (default) by short R1086



Chapter 5

NIOS Based Example Codes

This chapter provides several NIOS based examples for users to get started using the D8M-FMC Board.

5.1 D8M-FMC VIP Demonstration on TR5

This demonstration shows how to implement a D8M-FMC on a TR5 FPGA Board. The Altera VIP (Video Image Processing) suite is used to display images on the HDMI monitor. The Nios II processor is used to configure the I2C devices. There is a Camera10 IP, from Terasic in Qsys, which translates the 10-bits Bayer Pattern from the camera to the 30-bit RGB video stream format and feeds it to the Altera VIP. The other IP developed by Terasic for auto-focus is used to find the optimized focus settings of the user-defined image area.

■ Function Block Diagram

Figure 5-1 Block diagram of D8M-FMC VIP demonstration on TR5 shows the block diagram of D8M-FMC VIP demonstration on the TR5 Board. The two I2C master controllers are used to configure the camera module and MIPI-decoder in the D8M-FMC. The first I2C controller is used to configure the camera module, including the OV8865 image sensor and the VM149C. The second I2C controller is used to configure the MIPI Decoder TC358748XBG.

Note: The focus driver IC (VM149C) in the camera module is also configured by the Terasic auto-focus IP through its own I2C master controller. Users must make sure there is only one I2C master used one at a time.

The two GPIO controllers are used to retrieve the status of Buttons and Switches. The Histogram controller is used to build the histogram data for the 10-bit Bayer Pattern from the camera module. The image quality can be enhanced based on the analysis of histogram data. These controllers are all controlled by the NIOS II processor. The NIOS II program is stored in the On-Chip memory. The DDR3 controller is used to provide AVMM access interface for the DDR3-SODMM so the frame buffer in the **VIP Process** block can use DDR3 as video memory.

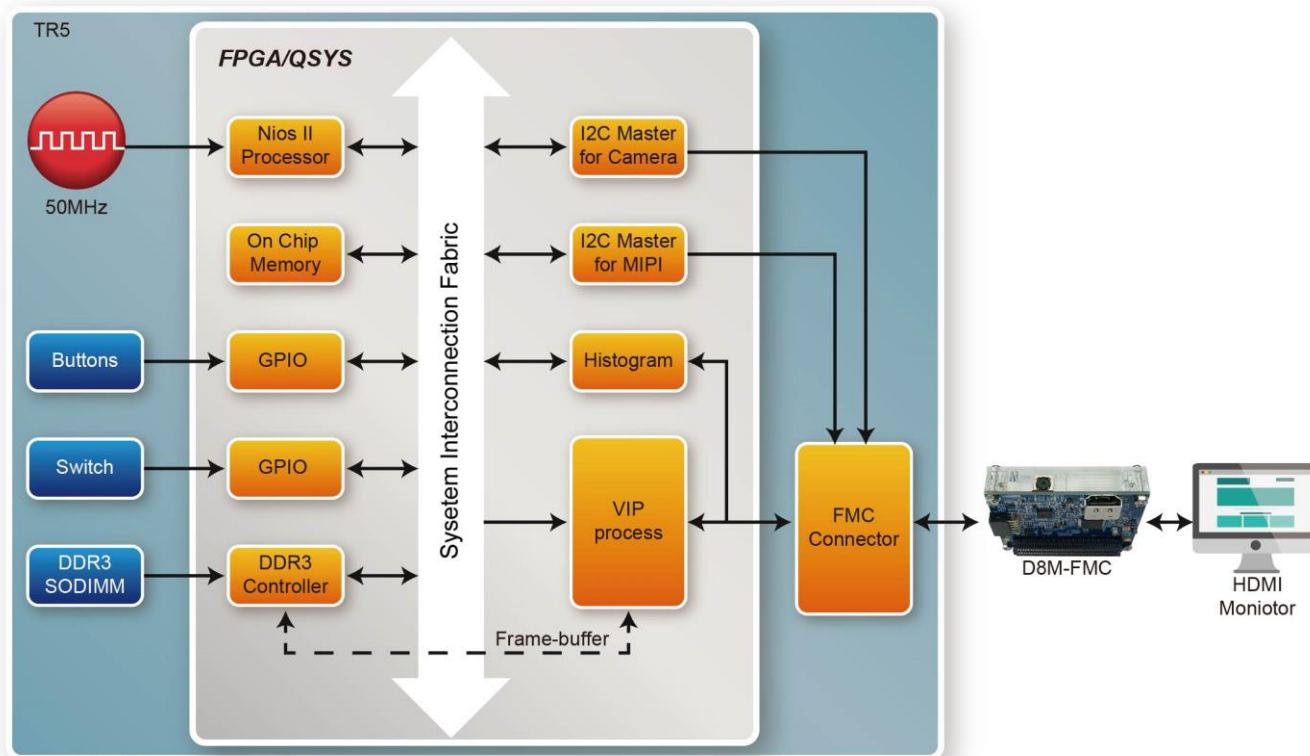

Figure 5-1 Block diagram of D8M-FMC VIP demonstration on TR5

The **VIP Process** contains a set of VIP as shown in **Figure 5-5**. In this demonstration, the Camera is configured to generate a 10-bit 1920x1080 pixel Bayer pattern. The Terasic CAMRA10 IP is used to convert the Bayer Pattern into a 1920x1080 30-bit RGB Altera VIP video stream. The Gamma Corrector is an Altera VIP. It is used to re-map the RGB video to get an enhanced video based on a 1024-entry LUT (Loop Up Table). The Terasic Autofocus is used to automatically find the proper focus position for the camera lens. The framebuffer is used to store the complete video frame for display later. The framebuffer uses the external DDR3-SO-DIMM as video memory. The Clock Video Output IP will translate the video stream to a 1920x1080 VGA format so the video can be displayed on the HDMI monitor.

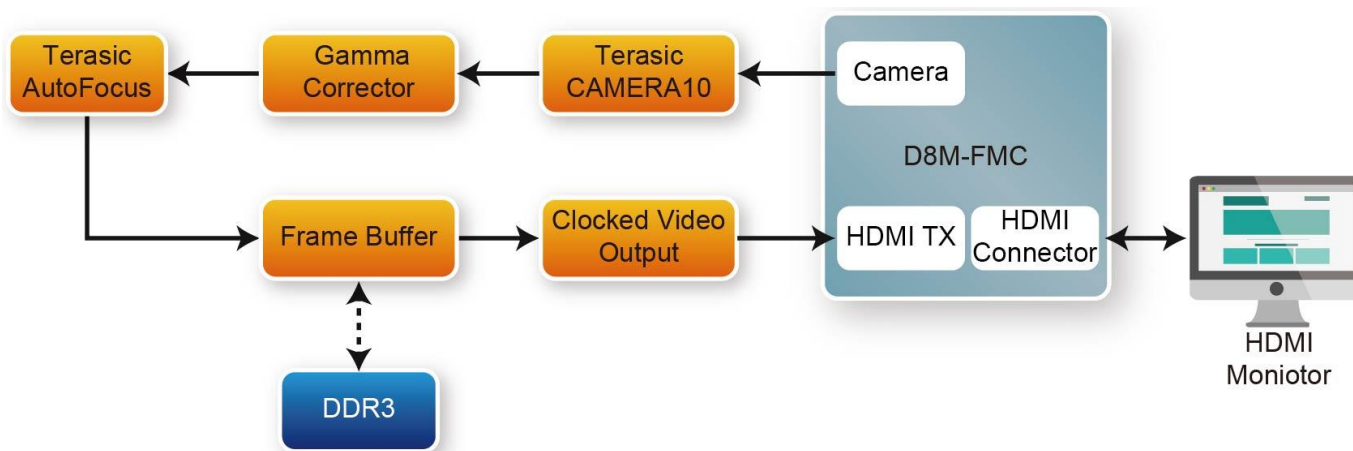

Figure 5-2 Block diagram of D8M-FMC VIP demonstration on TR5



Image Process

In this demonstration, the Altera Gamma Corrector VIP is used to remap the RGB value to get an enhanced value. The required LUT is calculated on NIOS II program based on the histogram data retrieved from the HISTOGRAM IP. In this demonstration, three enhanced methods are implemented:

- Histogram Equalization
- Histogram Stretching based on the highlight/shadow of current video frame
- Histogram Stretching based on fixed highlight/shadow

The Histogram Equalization is to remap the pixel level such that each gray level has the same intensity as shown in **Figure 5-3**.

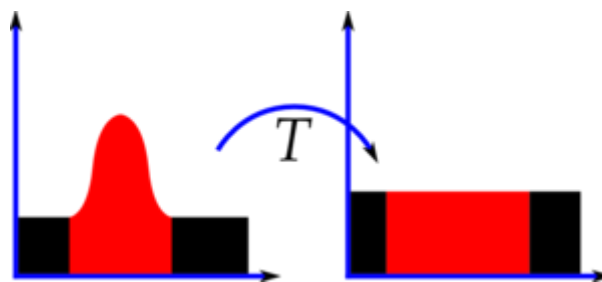

Figure 5-3 Histograms of an image before and after equalization

The histogram stretching is to stretch the histogram so the highlight and shadow is mapped to maximal and minimal pixel level. **Figure 5-4** shows a histogram stretch example for 8-bit gray salve image. The shadow point in the image will be remapped from 84 to 0, and the highlight point in the image will be remapped from the 153 to 255.

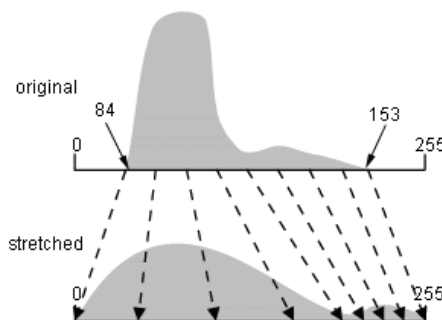

Figure 5-4 Histogram Stretch

Beside, Gamma encoding also implemented in this demonstration for the nonlinear feature of HDMI monitor. The Gamma LUT built by the following gamma encoding formula:

$$V_{out} = AV_{in}^{\gamma}$$



■ The default camera settings

In this demonstration, the default camera settings are:

- Resolution: 1920x1080
- Frame Rate: 30 fps
- Pixel Data: RAW10
- Bin Mode: 1

Users can change the settings base on their requirements.

■ Design Tools

- Quartus II v16.0.2 Standard Build 222
- Nios II Eclipse 16.0.2

■ Demonstration Source Code

- Quartus project directory: TR5_D8M_FMC_VIP
- Nios II Eclipse project workspace: TR5_D8M_FMC_VIP\software

■ Demonstration Batch File

- Demo batch file folder: demonstrations\TR5_D8M_FMC_VIP\demo_batch

■ Demonstration Setup

- Install D8M-FMC Board on the **FMC_D**(J10) connector of TR5 and make sure the screw is locked (See [Figure 5-5](#))
- Connect the HDMI connector on the D8M-FMC to a HDMI monitor (See [Figure 5-5](#))
- Connect a USB cable between the host PC and the USB connector (J6) on the TR5 board (See [Figure 5-5](#))
- Make sure DDR3-SODMM is installed on the TR5
- Make sure the VADJ of FMC_D is set to 2.5V by placing a jumper between JP9.7 and JP9.8, as shown in [Figure 5-6](#)
- Power on the TR5 board
- Execute the demo batch file “test.bat” under the batch file folder TR5_D8M_FMC_VIP\demo_batch
- The HDMI Monitor will start showing the video captured from the camera as shown in [Figure 5-7](#)
- LED indicators:
 - LED0:DDR3 init pass
 - LED1:DDR3 init done
 - LED2:DDR3 cal success
 - LED3:DDR3 cal fail
- Control Focus:
 - Press BUTTON0 to trigger the auto-focus function
 - Press BUTTON1 to ‘ - ’ adjust focus position in manual-focus
 - Press BUTTON2 to ‘ + ’ adjust focus position in manual-focus



- LUT(Loop Up Table) Image Process:
 - SW1/SW0 = DOWN/DOWN. No image process is applied
 - SW1/SW0 = DOWN/UP. Apply histogram equalization image process
 - SW1/SW0 = UP/DOWN. Apply histogram stretching
 - SW1/SW0 = UP/UP. Apply histogram stretching with fixed highlight/shadow
- Gamma Encoding:
 - SW2 = DOWN. No gamma encoding.
 - SW2 = UP. Apply gamma encoding.
- This demonstration also simply demonstrates the HDMI-Audio function ,it will produce a 1K sine wave voice when pressing BUTTON3.

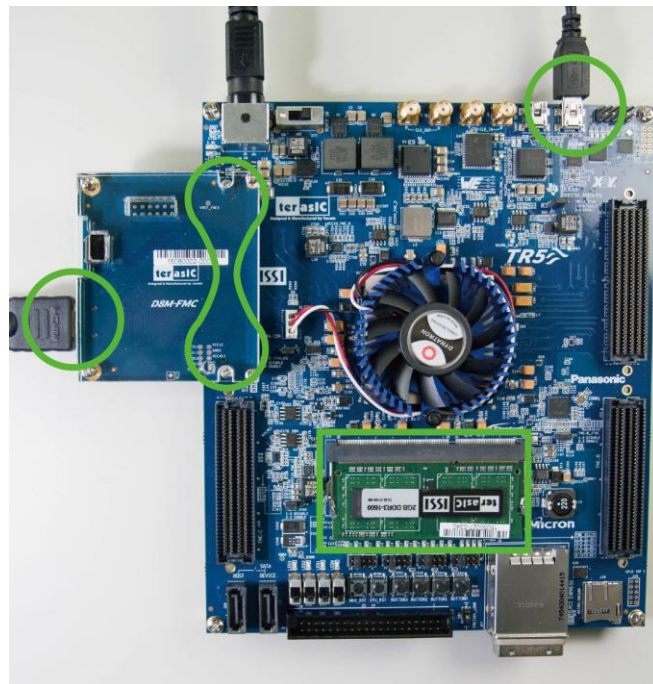

Figure 5-5 Setup TR5_D8M_FMC_VIP demonstration



Figure 5-6 Adjust FMC_D VADJ to 2.5V by short JP9.7 and JP9.8

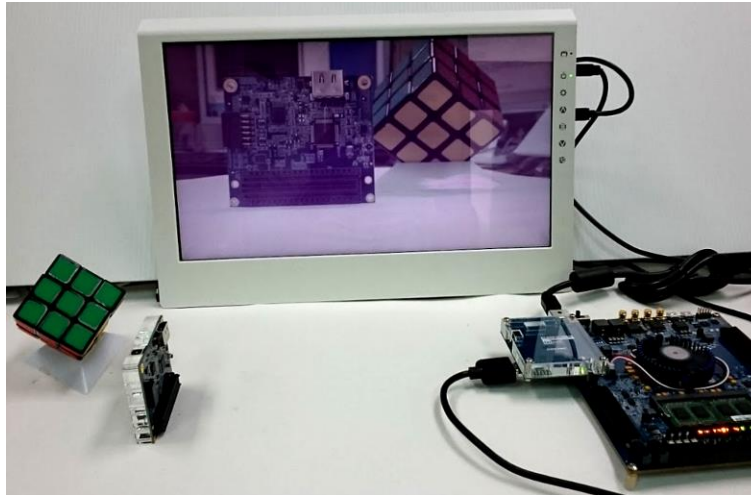

Figure 5-7 TR5_D8M_FMC_VIP demonstration running on TR5

5.2 D8M-FMC VIP Demonstration on Altera A10SoC

This demonstration shows how to implement a D8M-FMC on an Altera A10SoC FPGA Board. The demonstration code is almost as same as the one used for the TR5. The block diagram is also the same as the one used in the TR5 with the exception that the DDR3 controller is replaced by the DDR4 controller and the DDR3-SODMM is replaced by the DDR4 module. The image process and camera settings are the same as those used in TR5.

■ Design Tools

- Quartus II v16.0.2 Standard Build 222
- Nios II Eclipse 16.0.2

■ Demonstration Source Code

- Quartus project directory: A10SoC_D8M_FMC_VIP
- Nios II Eclipse project workspace: A10SoC_D8M_FMC_VIP\software

■ Demonstration Batch File

- Demo batch file folder: demonstrations\A10SoC_D8M_FMC_VIP\demo_batch

■ Demonstration Setup

- Install D8M-FMC Board on the **FMC_A**(J29) connector of A10SoC and make sure the screw is locked (See [Figure 5-8](#))
- Connect the HDMI connector on the D8M-FMC to a HDMI monitor (See [Figure 5-8](#))
- Connect a USB cable between the host PC and the USB connector (J22) on the A10SoC board (See [Figure 5-8](#))
- Make sure DDR4 module is installed on the A10SoC
- Make sure the FMC_A's VADJ is set to 1.8V by short J42.9 and J42.10 as shown in [Figure 5-9](#)
- Power on the A10SoC board



- Execute the demo batch file “test.bat” under the batch file folder
A10SoC_D8M_FMC_VIP\demo_batch
- The HDMI Monitor will start showing the video captured from the camera as shown in **Figure 5-10**
- Use push buttons and DIP switches, as shown **Figure 5-11** , to perform various functions.
- LED indicators:
 - LED0:DDR4 init pass
 - LED1:DDR4 cal success
 - LED2:DDR4 cal fail
- Control Focus:
 - Press Push Button 0 to trigger the auto-focus function
 - Press Push Button 1 to ‘ - ’ adjust focus position in manual-focus
 - Press Push Button 2 to ‘ + ’ adjust focus position in manual-focus
- LUT(Loop Up Table) Image Process:
 - DIP Switch-SW0/ SW1 = DOWN/DOWN. No image process is applied
 - DIP Switch-SW0/ SW1 = DOWN/UP. Apply histogram equalization image process
 - DIP Switch-SW0/ SW1 = UP/DOWN. Apply histogram stretching
 - DIP Switch-SW0/ SW1 = UP/UP. Apply histogram stretching with fixed highlight/shadow
- Gamma Encoding:
 - DIP Switch -SW2 = DOWN. No gamma encoding.
 - DIP Switch -SW2 = UP. Apply gamma encoding.
- This demonstration also simply demonstrates the HDMI-Audio function ,it will produce a 1K sine wave voice when pressing Push Button 2.



Figure 5-8 Setup A10SoC_D8M_FMC_VIP demonstration

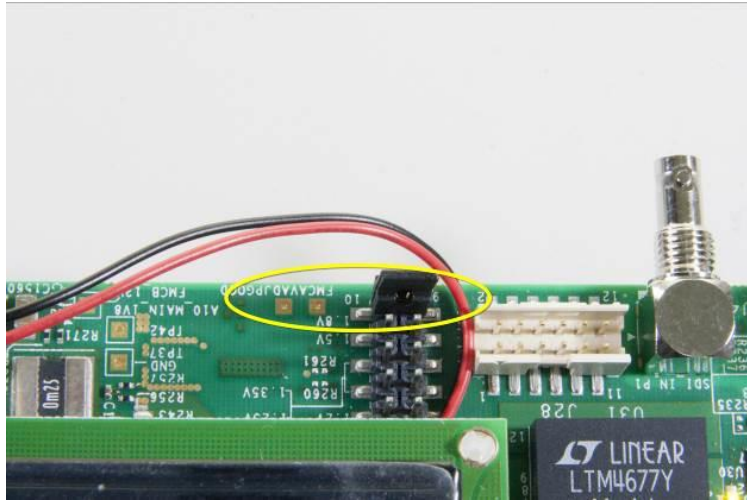

Figure 5-9 Adjust FMC_A VADJ to 1.8V by short J42.9 and J42.10

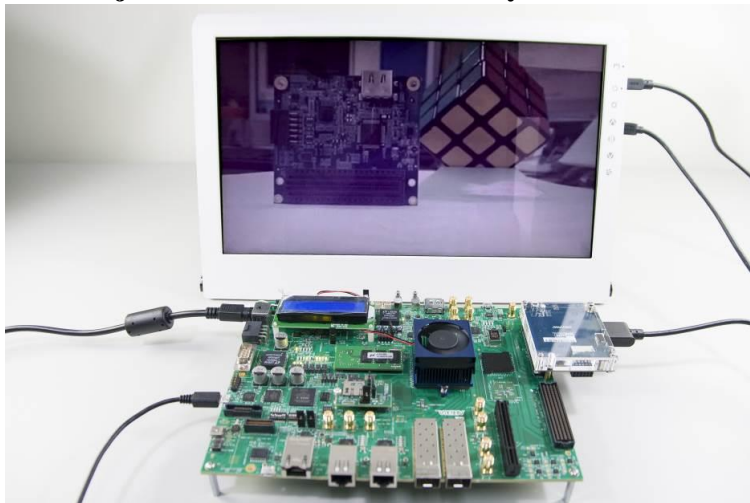

Figure 5-10 A10SoC_D8M_FMC_VIP demonstration running on A10SoC

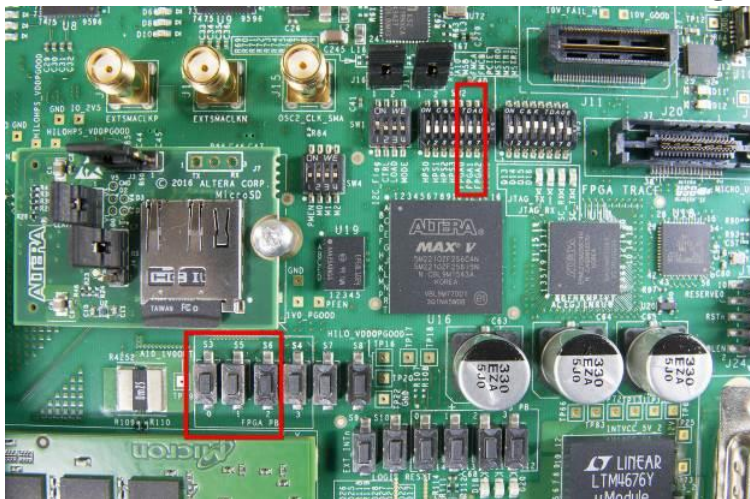

Figure 5-11 Push Button and DIP Switch



5.3 D8M-FMC VIP Demonstration on Altera A10GFP

This demonstration shows how to implement a D8M-FMC on an Altera A10GFP FPGA Board. The demonstration code is almost as same as the one used TR5. The block diagram is also the same as the one used in TR5 except the DDR3 controller is replaced by the DDR4 controller and the DDR3-SODMM is replaced by DDR4 module. The image process and camera setting are the same as those used in TR5.

■ Design Tools

- Quartus II v16.0.2 Standard Build 222
- Nios II Eclipse 16.0.2

■ Demonstration Source Code

- Quartus project directory: A10GFP_D8M_FMC_VIP
- Nios II Eclipse project workspace: A10GFP_D8M_FMC_VIP\software

■ Demonstration Batch File

- Demo batch file folder: demonstrations\A10GFP_D8M_FMC_VIP\demo_batch

■ Demonstration Setup

- Install D8M-FMC Board on the **FMC_A(J1)** connector of A10GFP and make sure the screw is locked (See [Figure 5-12](#))
- Connect the HDMI connector on the D8M-FMC to a HDMI monitor (See [Figure 5-12](#))
- Connect a USB cable between the host PC and the USB connector (J3) on the A10GFP board (See [Figure 5-12](#))
- Make sure DDR4 module is installed on the A10GFP
- Make sure the FMC_A's VADJ is set to 1.8V by short R1086 as shown in [Figure 5-13](#). (The A10GFP version is Rev E3.1)
- Power on the A10GFP board
- Execute the demo batch file "test.bat" under the batch file folder A10GFP_D8M_FMC_VIP\demo_batch
- The HDMI Monitor will start showing the video captured from the camera as shown in [Figure 5-14](#)
- Use push buttons and DIP switches, as shown [Figure 5-15](#), to perform various functions
- LED indicators:
 - LED0:DDR4 init pass
 - LED1:DDR4 cal success
 - LED2:DDR4 cal fail
- Control Focus:
 - Press Push Button 0 to trigger the auto-focus function
 - Press Push Button 1 to ' - ' adjust focus position in manual-focus
 - Press Push Button 2 to ' + ' adjust focus position in manual-focus
- LUT(Loop Up Table) Image Process:
 - DIP Switch-SW0/ SW1 = DOWN/DOWN. No image process is applied



- DIP Switch-SW0/ SW1 = DOWN/UP. Apply histogram equalization image process
- DIP Switch-SW0/ SW1 = UP/DOWN. Apply histogram stretching
- DIP Switch-SW0/ SW1 = UP/UP. Apply histogram stretching with fixed highlight/shadow
- Gamma Encoding:
 - DIP Switch-SW2 = DOWN. No gamma encoding.
 - DIP Switch-SW2 = UP. Apply gamma encoding.
- This demonstration also simply demonstrates the HDMI-Audio function ,it will produce a 1K sine wave voice when pressing Push Button 2.

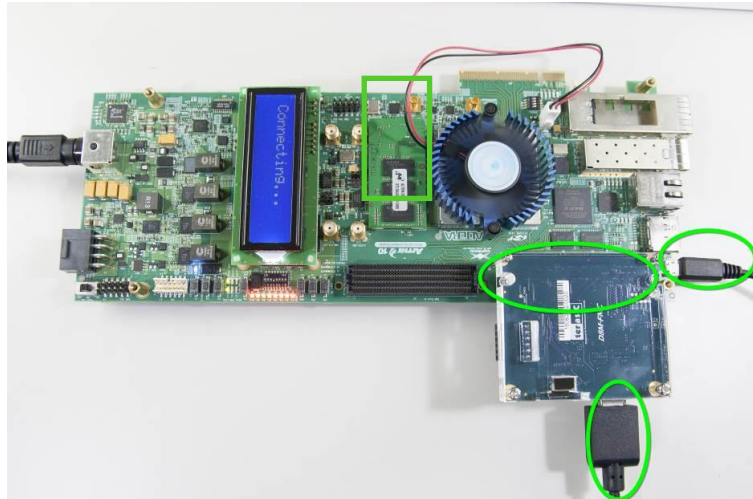

Figure 5-12 Setup A10SoC_D8M_FMC_VIP demonstration



Figure 5-13 Adjust FMC_A VADJ to 1.8V (default) by short R1086

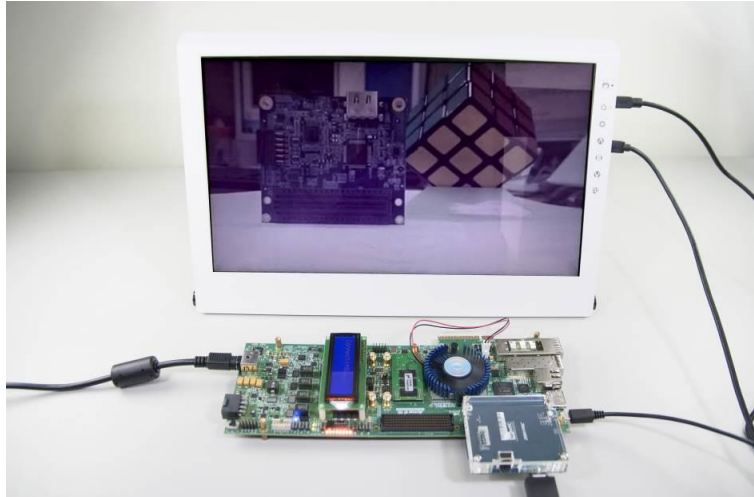

Figure 5-14 A10SoC_D8M_FMC_VIP demonstration running on A10SoC

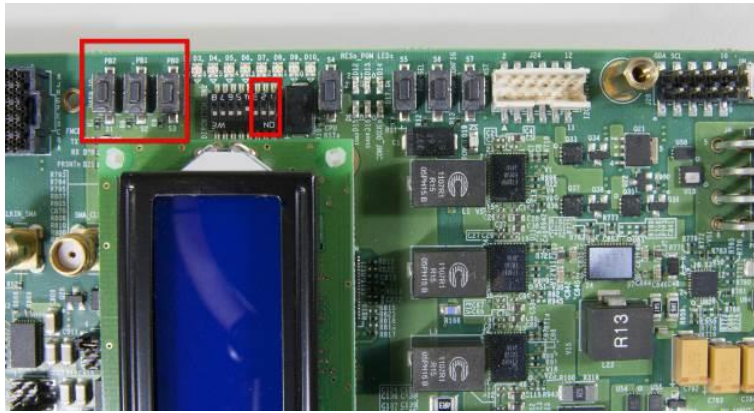

Figure 5-15 Push Button and DIP Switch



Chapter 6

Appendix

Revision History

Version	Change Log
V1.0	Initial Version
V1.1	Modify VCM149C to VM149C

Copyright Statement

Copyright © 2016 Terasic Inc. All rights reserved.