

DEUTSCH

Industrial Products Division



CYLINDRICAL ENVIRONMENTAL CONNECTORS

HD10 SERIES TECHNICAL MANUAL

Table of Contents

HD10 SERIES

Introduction



DEUTSCH

INDUSTRIAL PRODUCTS DIVISION

3850 Industrial Avenue, Hemet, California 92545

Telephone (909) 765-2250 • Fax (909) 765-2255

<http://www.deutschipd.com>

DEUTSCH IS THE DIFFERENCE...

Deutsch is well known for its high performance connectors. It has built a solid reputation in the world-wide heavy-duty vehicle market. The need for rugged critical circuit interconnections is now growing as our customers keep pace with evolving advances in electronics technology. Deutsch Industrial Products Division is ready to meet this demand for sophisticated custom interfaces.

With a rich company applications heritage, Deutsch IPD draws on thousands of critical circuit designs for subsystems and assemblies in:

- Engine controllers
- Trucks and buses
- Heavy equipment and farm machinery
- Offroad, marine and recreational vehicles
- Plant equipment and robotics
- Communication systems

Deutsch Industrial Products Division provides in-house services: engineering, materials research, prototypes, testing, tooling, dedicated assembly lines and more. When it comes to new product designs or updating mature ones or process optimization, Deutsch expertise and value make the difference.

Table of Contents

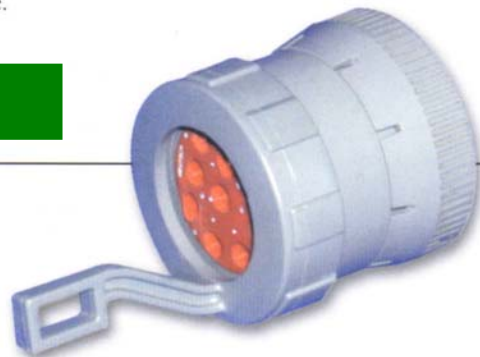

INDEX

HD10 SERIES

A Technical Discussion	3
Specifications and Numbering System.....	4
Drawings	5
Contacts	6
Sealing Plugs, Contact Removal Tools.....	7
and Backshells	

Sales & Service

Information contained herein is for reference only.

Consult factor for new envelope drawings, updated specifications, and additions to product lines.

hd10series

©Copyright 2001-2002 Deutsch ECD





DESIGNED TO DECREASE COSTS AND UP-GRADE PERFORMANCE

The Deutsch HD10 Series is designed to provide a solution to today's interconnection problems found in the heavy duty industry. The HD10 is a thermoplastic cylindrical connector utilizing crimp type contacts that are quickly and easily inserted and removed. The HD10 Series eliminates problems associated with assembly and maintenance time and is designed for a long service life. For an upgrade in performance, specify the HD 10 Series and downgrade your total installed costs.

HD10 FEATURES AND BENEFITS

SHELL STYLES AND CONFIGURATIONS

Rugged thermoplastic shells are available in non-threaded and threaded (for rear hardware) configurations. Receptacles are tooled in inline or square flange mounting styles. Shell arrangements of 3, 4, 5, 6 and 9 utilizing 4, 12 and 16 size contacts that accept 6, 12, 14, 16, 18 and 20 AWG wire meet most wire-break applications.

MATING CHARACTERISTICS

A tricam coupling is utilized in the HD10 design that permits quick mating and unmating. Keying silos are molded in the plug half that ease blind mating problems and provide protection for the socket contacts. Both the plug and receptacles are index keyed for visual alignment before coupling. To mate, simply rotate the plug body until it slips into the receptacle, rotate the coupling ring approximately one-quarter turn until a "click" is heard, and that's it, simple and quick.

Information contained herein is for reference only.

Consult factor for new envelope drawings, updated specifications, and additions to product lines.

hd10series

©Copyright 2001-2002 Deutsch ECD

SEALED AGAINST MOISTURE AND CONTAMINANTS

Unlike other conventional cylindrical plastic multi-pin connectors, the Deutsch HD10 Series connector is a completely sealed unit. The rear grommets of the plug and receptacle feature integrated silicone wire seals which automatically seal each wired contact as it is locked in place during installation. There are no extra components to be installed on the contact/wire assembly and no potting needed to achieve sealing. The HD10 connector family was designed to be an environmentally sealed connector assembly, not a redesign from an existing product line. All this means a faster, easier, trouble-free assembly. An interfacial seal fabricated from tear-resistant high temperature silicone is located in the plug. When mated, the contacts are protected from moisture, sand, dust, lubricating oils, fuel, road salt, hydraulic fluid, grease, mud and other contaminants encountered in heavy-duty operations.

CONTACT RETENTION SYSTEM DECREASES INSTALLATION COSTS AND INCREASES RELIABILITY

The HD10 Series uses either crimp type, solid copper alloy contacts or lower-cost stamped and formed contacts for damage-proof performance and continuous high operating current loads without overheating. The contacts are crimp terminated using automatic tooling for production and inexpensive, readily available hand tools for field maintenance. Deutsch termination procedures recommend no soldering after properly crimped contacts are completed. After crimping, these contacts are easily installed by simply pushing the contact into place by hand. Contacts are positively secured by the use of "fingers" in the connector which lock behind the shoulder of the contact preventing accidental dislodging. Although securely locked in place, these contacts can be quickly and easily removed by the use of an inexpensive, non-conductive removal tool. The HD10 contact call-outs are the same used in all Deutsch HD, DRC and DT Series of connector products. When used together, this common contact system slashes inventory costs and reduces the chance of assembly and operator errors caused by the hundreds of different types of terminations and processes used within a single-harness assembly.

A GENERAL-PURPOSE, ECONOMICAL CONNECTOR SELECTION

The Deutsch HD10 Series of interconnections brings to the heavy-duty connector industry a general-purpose, environmentally sealed connector that is easy to assemble and meets the demand of total support for advanced electronic equipment technology today and in the future.



GENERAL PERFORMANCE SPECIFICATIONS

Temperature

Operating at temperatures from -55^o C to + 125^o C.

Durability

No electrical or mechanical defects after 100 cycles of engagement or disengagement.

Physical Shock

No unlocking, unmating or other unsatisfactory result during or after 50 g's in each of three mutually perpendicular planes. No electrical discontinuities longer than 1 microsecond. MIL-STD 202, Method 213, Condition "C."

Contact Current Rating @ 125^oC (continuous)

Contact Size	Max. Current
#4	100 amps
#12	25 amps
#16	13 amps

Insulation Resistance

1000 megohms min. at 25^o C.

Vibration

Maintains continuity and exhibits no mechanical or physical damage during or while subject to a sinusoidal vibration, having an amplitude of .060 inches double amplitude and the frequency varied linearly between limits of 10 to 2000 to 10 Hz with a maximum force of 20g's. No electrical discontinuities longer than 1 microsecond.

Moisture Resistance

Water does not penetrate seals when submerged in 3 feet of water.

Corrosion Resistance

Connectors show no evidence of corrosion after exposure to 48 hours of salt spray per MIL-STD 1344 method 1001.

Fluid Resistance

Connectors show no damage when exposed to most fluids used in industrial applications.

Dielectric Withstanding Voltage:

Current leakage less than 2 milliamps at 1500 VAC.

Crimp Tensile Strength: (Solid)

Size	Contacts	Tensile Strength
#4	300 lbs.	
#12	70 lbs.	
#16	25 lbs.	

CONTACT MILLIVOLT DROP (SOLID)

Wire (AWG)	Test Current	Milivolt Drop*
4	100	60
12	25	60
16	13	60

*Less drop through wire

Crimp Tensile Strength: (Stamped & Formed)

Size	Contacts	Tensile Strength
#12	70 lbs.	
#16	38 lbs.	

CONTACT MILLIVOLT DROP (STAMPED & FORMED)

Wire Gauge	Test Current	Milivolt Drop*
12	25 Amps	100
16	13 Amps	100

*Less drop through wire

DEUTSCH HD10 SERIES PART NUMBERING SYSTEM

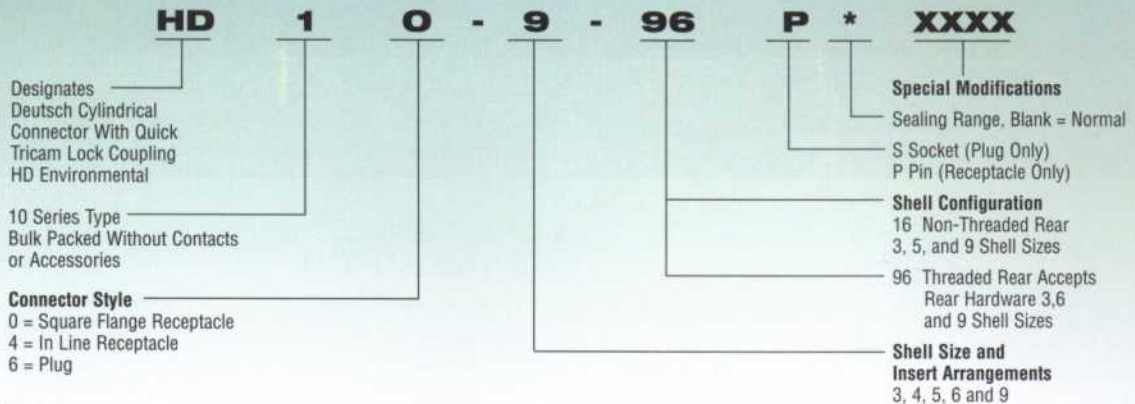

ENVIRONMENTAL MATERIAL SPECIFICATIONS

Plug:

Shell: Thermoplastic
Insert: Retainer - Thermoplastic
Grommet - Silicone rubber

Receptacle:

Shell: Thermoplastic
Insert: Retainer - Thermoplastic Grommet and Interfacial Seal - Silicone rubber

Solid Contacts

Pin: Copper alloy
Socket: Copper alloy
Finish: Nickel plating*

Sealing Plugs

Thermoplastic: Size 12 thru 16
Elastomer: Size 4

Stamped & Formed Contact

Pin: Copper alloy
Socket: Copper alloy
Finish: Nickel plating*

*Optional: Gold plating (consult factory)

Information contained herein is for reference only.

Consult factor for new envelope drawings, updated specifications, and additions to product lines.

hd10series

©Copyright 2001-2002 Deutsch ECD



ENVIRONMENTAL

CONNECTOR STYLE



Plug HD 16

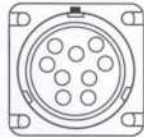

Square Flange Receptacle HD 10



Inline Receptacle HD 14

SHELL CONFIGURATION - 16 (unthreaded)

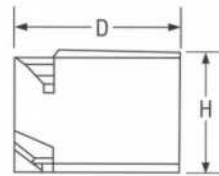
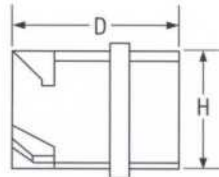
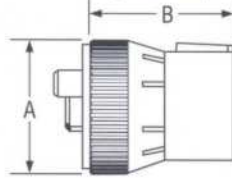

SHELL CONFIGURATION - 96 (threaded)

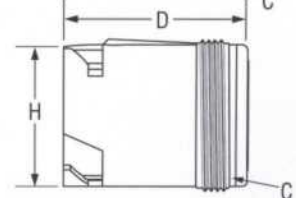
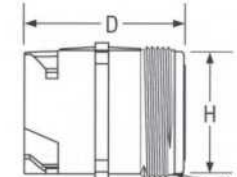
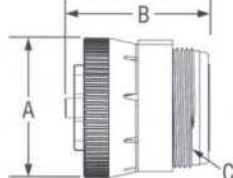

SHELL SIZE	PLUG COUPLING RING DIAMETER ± .015 A	PLUG OVERALL LENGTH ± .015 B	PLUG & RECEPTACLE REAR THREADS UNEF-2A C	RECEPTACLE OVERALL LENGTH ± .015 D	SHELL DIAMETER ± .015 H
3	1.069	1.609	.9375-20	1.639	.857
4	1.595	1.639	1.3750-18	1.639	1.279
5	1.218	1.609	—	1.639	1.001
6	1.453	1.609	1.3125-18	1.639	1.141
9	1.595	1.632	1.3750-18	1.660	1.279

INSERT ARRANGEMENTS



3-16 / 3-96*
3 SIZE 16
N,E

*see shell configuration top of page



4-4
1 SIZE 4
3 SIZE 16

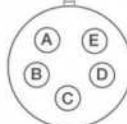

5-16
5 SIZE 16

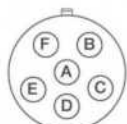

6-12
6 SIZE 12

Cavity ID From Front of Receptacle

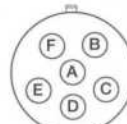

6-96
6 SIZE 16



9-16
9 SIZE 16



9-96
9 SIZE 16
N,E

SQUARE FLANGE MOUNTING HOLE DIMENSIONS



3-SIZE

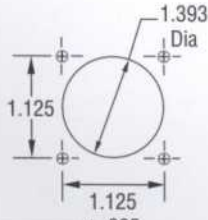

4-SIZE

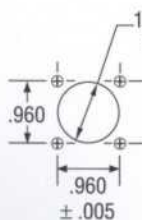

5-SIZE

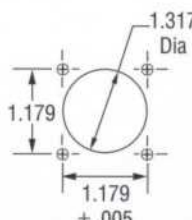

6-SIZE

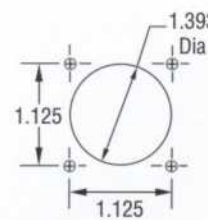

9-16 SIZE

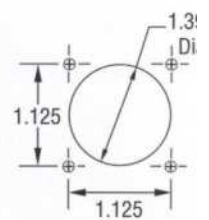

9-96 SIZE

Diameter of Mounting Holes .125

Information contained herein is for reference only.

Consult factor for new envelope drawings, updated specifications, and additions to product lines.

hd10series



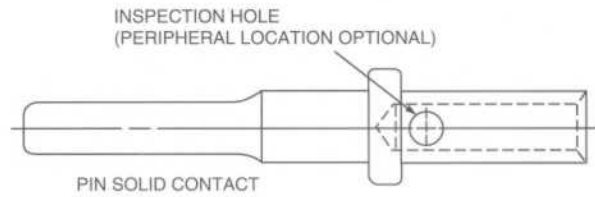
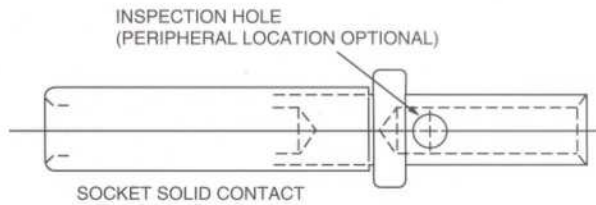

SOLID CONTACTS

Contact Part Number	Size & Type	Wire Gauge Range	Recommended Strip Length	Hand Crimp Tool	Production Crimp Tool
0460-202-16141 0462-201-16141	16 PIN 16 SOCKET	16, 18 & 20 AWG (1.0-.05mm ²) 16, 18 & 20 AWG (1.0-.05mm ²)	.250-.312 (6.35-7.92mm) .250-.312 (6.35-7.92mm)	HDT-48-00 HDT-48-00	HDP-400 HDP-400
0460-215-16141 0462-209-16141	16 PIN 16 SOCKET	14 AWG (2.0 mm ²) 14 AWG (2.0 mm ²)	.250-.312 (6.35-7.92mm) .250-.312 (6.35-7.92mm)	HDT-48-00 HDT-48-00	HDP-400 HDP-400
0460-204-12141 0462-203-12141	12 PIN 12 SOCKET	12 & 14 AWG (3.0-2.0mm ²) 12 & 14 AWG (3.0-2.0mm ²)	.222-.284 (5.64-7.21mm) .222-.284 (5.64-7.21mm)	HDT-48-00 HDT-48-00	HDP-400 HDP-400
0460-204-0490 0462-203-04141	4 PIN 4 SOCKET	6 AWG (13.0mm ²) 6 AWG (13.0mm ²)	.430-.492 (10.92-.12.50mm) .430-.492 (10.92-.12.50mm)	HDT-04-08 HDT-04-08	HDP-400 HDP-400

*See Envelope Print 0425-205-0000. Consult factory for alternative finishes.

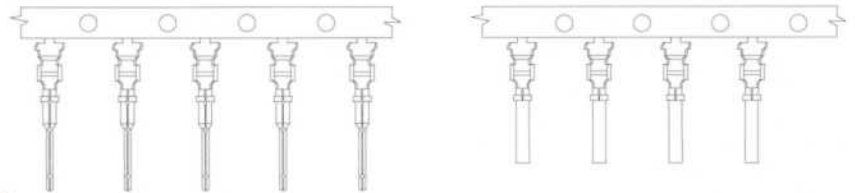

STAMPED & FORMED CONTACTS

Contact Part Number	Size & Type	Wire Gauge Range	Insulation O.D.	Recommended Strip Length	Hand Crimp Tool	Production Crimp Tool Die
1060-16-0722 1062-16-0722	16 PIN 16 SOCKET	16 & 18 AWG (.75mm-2.0mm ²) 16 & 18 AWG (.75mm-2.0mm ²)	.075-.115 (1.90-2.92mm) .075-.115 (1.90-2.92mm)	.150-.200 (3.81-5.08mm) .150-.200 (3.81-5.08mm)	DTT-16-00 DTT-16-00	DCT16-02-00 DCT16-02-00
1060-16-0622 1062-16-0622	16 PIN 16 SOCKET	16 & 18 AWG (.50-1.0mm ²) 16 & 18 AWG (.50-1.0mm ²)	.055-.083 (1.40-2.10mm) .055-.083 (1.40-2.10mm)	.150-.200 (3.81-5.08mm) .150-.200 (3.81-5.08mm)	DTT-16-00 DTT-16-00	DCT16-02-00 DCT16-02-00
1060-16-0122 1062-16-0122	16 PIN 16 SOCKET	16 & 18 AWG (.75-1.5mm ²) 16 & 18 AWG (.75-1.5mm ²)	.075-0.140 (1.90-3.55mm) .075-0.140 (1.90-3.55mm)	.150-.200 (3.81-5.08mm) .150-.200 (3.81-5.08mm)	DTT-16-00 DTT-16-00	DCT16-02-00 DCT16-02-00
1060-14-0122 1062-14-0122	16 PIN 16 SOCKET	14 & 16 AWG (2.0-1.0mm ²) 14 & 16 AWG (2.0-1.0mm ²)	.095-.150 (2.41-3.81mm) .095-.150 (2.41-3.81mm)	.150-.200 (3.81-5.08mm) .150-.200 (3.81-5.08mm)	DTT-16-00 DTT-16-00	DCT16-02-00 DCT16-02-00
1060-12-0166 1062-12-0166	12 PIN 12 SOCKET	12 & 14 AWG (4.0-2.0mm ²) 12 & 14 AWG (4.0-2.0mm ²)	.113-.176 (2.87-4.47mm) .113-.176 (2.87-4.47mm)	.225-.275 (5.72-6.99mm) .225-.275 (5.72-6.99mm)	DTT-12-00 DTT-12-00	DCT12-02-00 DCT12-02-00

**For proper dies and stamped & formed crimp dimensions - See Envelope 0425-208-0000 12 Size
0425-203-0000 16 Size Consult factory for alternate finishes.

Information contained herein is for reference only.

Consult factor for new envelope drawings, updated specifications, and additions to product lines.

hd10series

©Copyright 2001-2002 Deutsch ECD



HD10 SERIES

Sealing Plugs, Contact Removal Tools and Backshells

SEALING PLUG

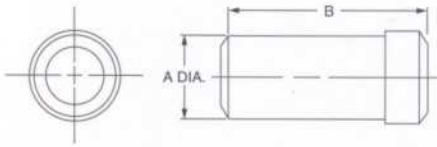

PART NUMBER	CONT. SIZE	A DIA.±.010	B DIM±.030
114017	12/16	.121	.575
114019	4	.312	.750

CONTACT REMOVAL PLUG

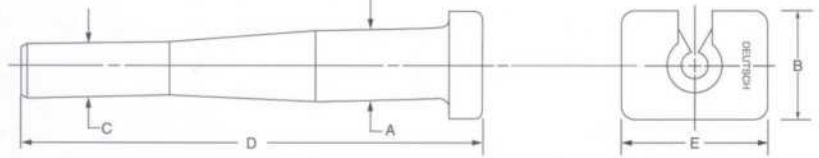

CONTACT SIZE	WIRE RANGE AWG	PART NUMBER	±.015 A	±.031 B	REF. C	REF. D	±.031 E	COLOR
16	16-18	0411-204-1605	.286	.500	.160	2.275	1.000	Blue
12	14	0411-291-1405	.286	.500	.180	2.230	1.000	Green
12	12-14	114010	.350	.625	.202	2.300	1.250	Yellow
4	6	114009	.740	.875	.435	2.250	1.500	White

HD10 PROTECTIVE CAPS AND BACKSHELLS

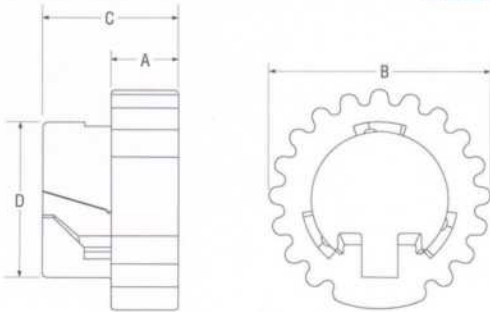

HDC14 PROTECTIVE COVER FOR PLUG

SIZE	±.025 A	±.025 B	±.025 C	±.025 D
HDC14-3	.370	1.221	.750	.863
HDC14-6	.367	1.448	.740	1.123
HDC14-9	.370	1.650	.750	1.279

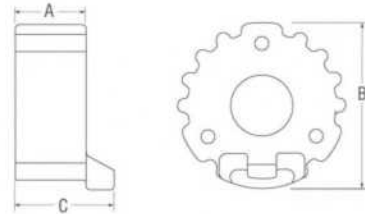

HDC16 PROTECTIVE COVER FOR RECEPTACLE

SIZE	±.025 A	±.025 B	±.025 C
HDC16-3	.492	1.176	.692
HDC16-5	.492	1.320	.692
HDC16-6	.492	1.443	.692
HDC16-9	.487	1.580	.670

HDC18 BACKSHELL

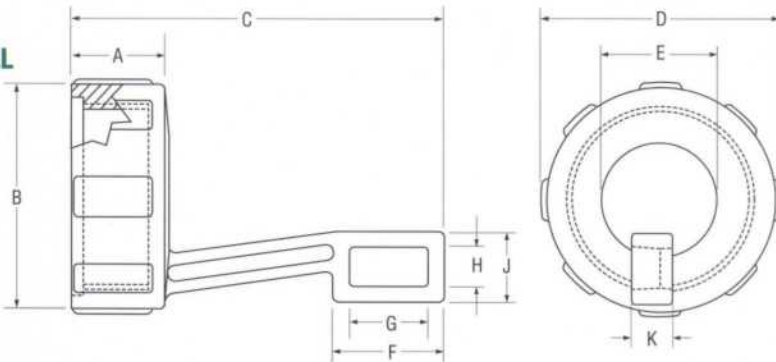

SIZE	±.025 A	±.025 B	±.025 C	±.025 D	±.025 E	±.025 F	±.025 G	±.025 H	±.025 J	±.025 K	THREAD
HD18-003	.465	1.138	1.865	1.188	.577	.560	.400	.200	.360	.200	.9375-20 UNEF-REF
HD18-005	.365	1.281	1.765	1.313	.720	.560	.400	.200	.360	.200	1.0625-18 UNEF-REF
HD18-006	.465	1.513	1.865	1.563	.861	.560	.400	.200	.360	.200	1.3125-18 UNEF-REF
HD18-009	.465	1.570	1.850	1.625	1.000	.560	.400	.200	.360	.200	1.375-18 UNEF-REF

Information contained herein is for reference only.

Consult factor for new envelope drawings, updated specifications, and additions to product lines.

DEUTSCH

Industrial Products Division

COMMON CONTACT SYSTEM

DEUTSCH COMMON CONTACT SYSTEM

Fundamental to the Deutsch connector series is the principle that all wires are terminated by a single contact system. The only variation in contacts is that dictated by wire gauge. The word "common" describes the Deutsch contact system well. Deutsch contacts, whether solid or stamped and formed, can be assembled into the entire Deutsch connector family. Let's look at the common system of contacts, tooling, processes, and terminations in detail:

COMMON CONTACTS

The basic system uses five contact sizes: 4, 8, 12, 16, & 20. These are the only contacts that an O.E.M. or their supplier need stock no matter what connector is being terminated. Two styles of Deutsch contacts are available - solid crimp types, manufactured by a cold heading process of solid copper alloys. Stamped and formed contacts are manufactured with a series of progressive dies. Both contacts are interchangeable within the connector and are selected based upon the user's application. Stocking costs, engineering costs, and termination costs are all slashed, because the number of evaluations, test procedures, test reports, process standards, drawing notes, etc., are reduced, if not eliminated.

COMMON TOOLING

Two hand crimp tools are used to crimp the five different sizes of contacts to the wire end. For semi-automation to full automation, one universal crimp tool will crimp the volume required for wire termination.

COMMON PROCESSING

Using Deutsch contacts means that the way an O.E.M. supplier attaches a wire to its terminus never varies. This procedural standard allows electrical workers to become highly proficient in terminating Deutsch connectors.

COMMON TERMINATIONS

The selection of Deutsch connectors means that all contact terminations will be the same, thus reducing the chance of errors in the harness system. Performance, reliability, and maintainability are critical to any electrical system. The use of a common contact system eliminates many of the failures reported in harnesses where hundreds of different types of terminations are used. The end result of selecting Deutsch is increased profits and long term performance.



For Regional Information Contact ...

DEUTSCH

INDUSTRIAL PRODUCTS DIVISION

3850 Industrial Avenue, Hemet, California 92545

Telephone (909) 765-2250 • Fax (909) 765-2255