

DRAWING MADE IN THIRD ANGLE PROJECTION
 THIS DRAWING IS UNPUBLISHED.
 COPYRIGHT 1983
 RELEASED FOR PUBLICATION
 BY AMP INCORPORATED. ALL INTERNATIONAL RIGHTS RESERVED.

19

LOC	DIST	REV	ZONE	LTN	DESCRIPTION	DATE	APPD
G	14			A	REVISED PER 0720-0230-93	2/28/94	DAV

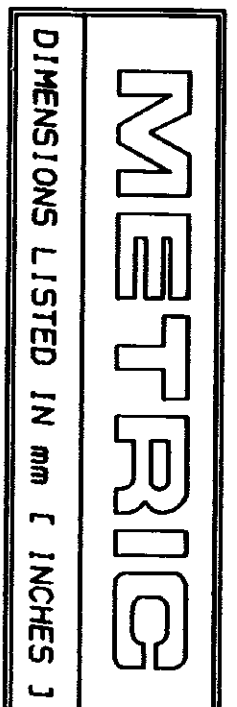

AMP WIRE RANGE	UL E13288 Listed
12-10 AWG STRANDED	12-10 AWG STRANDED
NOT CERTIFIED	MILITARY P/N AND CLASS
NOT CERTIFIED	NOT APPLICABLE

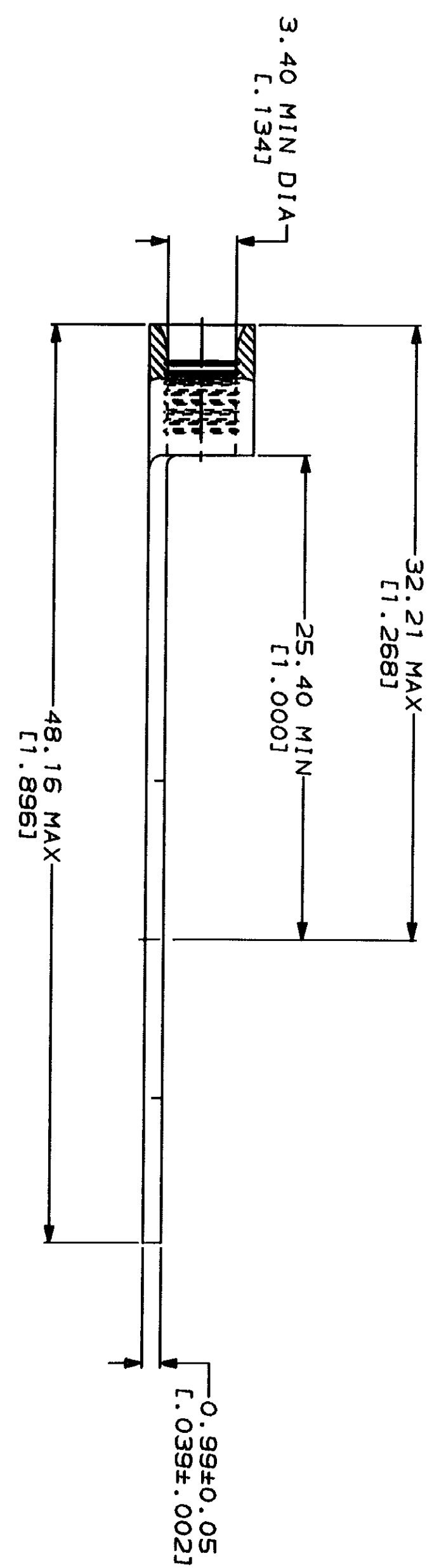
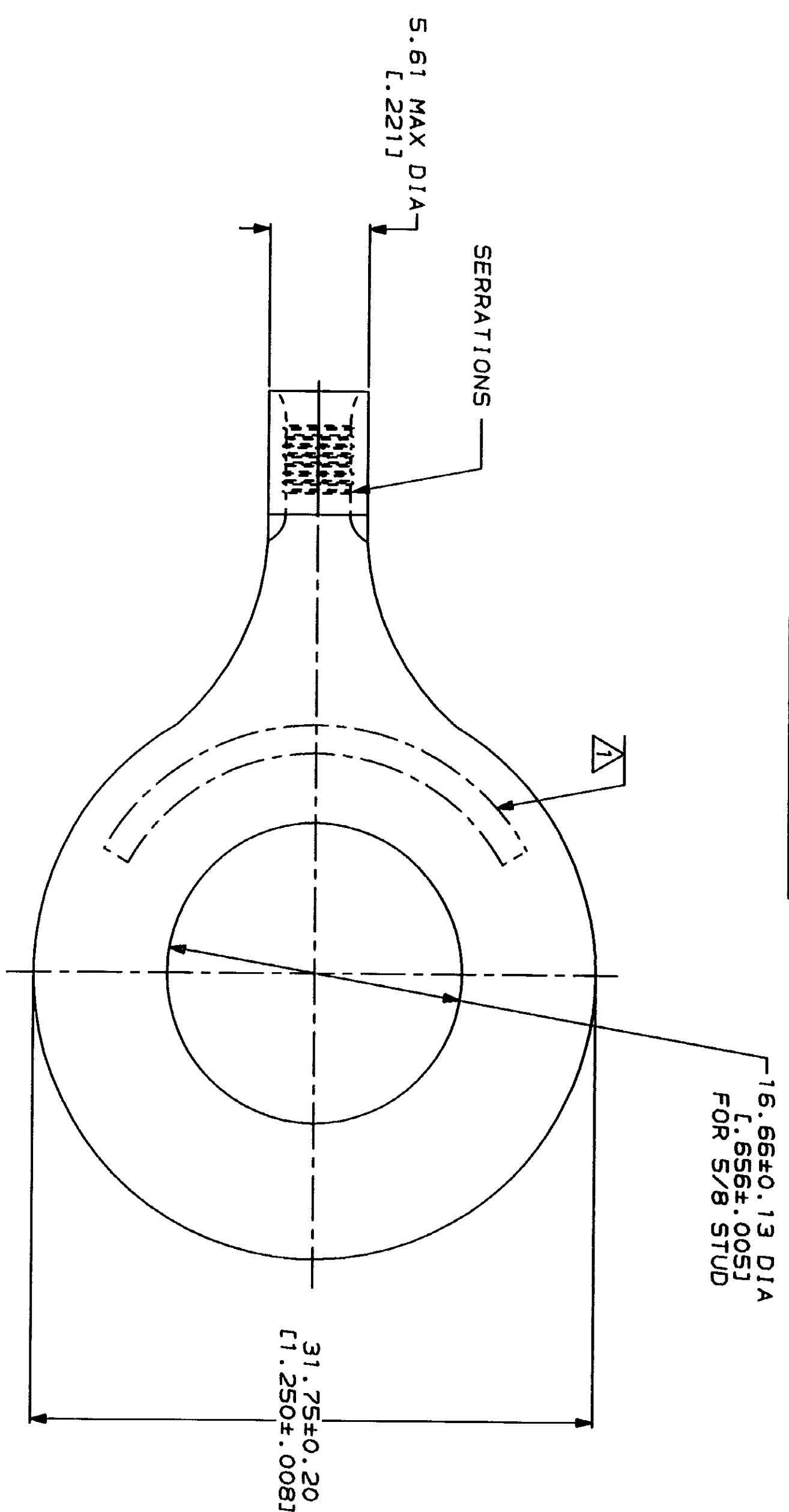

AMP INCORPORATED
 CUSTOMER SERVICE SYSTEMS

FOR ADDITIONAL PRODUCT INFORMATION OR COPIES OF DRAWINGS AND TECHNICAL DOCUMENTS
 PRODUCT INFORMATION CENTER
 1-800-522-6752

FOR APPLICATION TOOLING INFORMATION
 TOOLING ASSISTANCE CENTER
 1-800-722-1111

FOR ORDER ENTRY
 1-800-526-5142

MAX RECOMMENDED OPERATING TEMPERATURE: 170°C MAX

VOLTAGE RATING: NOT APPLICABLE

WIRE CROSS SECTIONAL AREA RANGE: 2.62-6.64mm² [5,180-13,100] CIR MILS STRANDED

DO NOT SCALE PRINT. UNLESS SPECIFIED DIMENSIONS IN MILLIMETERS - TOLERANCES ON: 2 PLC DEC # - - 3 PLC DEC # - - ANGLES MATERIAL COPPER PER ASTM B-152 ANNEALED

FINISH TIN PLATE

0.00254 [L.000100] MIN THK PER MIL-T-10727

DR 2-9-93 TA BRINKMAN	NAME	AMP
CHK 2-9-93 DA PATTERSON	TERMINAL, RING TONGUE, BUDGET	AMP Incorporated Harrisburg, PA 17105-3608
APPD 2-9-93 DE MILLER	SIZE	CAGE CODE
APPD 2-9-93 JL NECKLEY	00779	00779
PRODUCT SPEC	SCALE	DRAWING NO
APPLICATION SPEC	4:1	320761
WEIGHT -	SHEET	PART NO
	1 OF 1	320761