

THIS DRAWING IS UNPUBLISHED. RELEASED FOR PUBLICATION
© COPYRIGHT - By - ALL RIGHTS RESERVED.

REVISIONS				
P	LTR	DESCRIPTION	DATE	APVD
D2		REVISED PER ECO-11-010839	25MAY11	RK HMR
D3		REVISED PER ECO-18-002614	28FEB2018	RS DR
D4		REVISED PER ECO-19-015407	22OCT2019	RS DR

AMP
WIRE RANGE
26-22 AWG
STRANDED

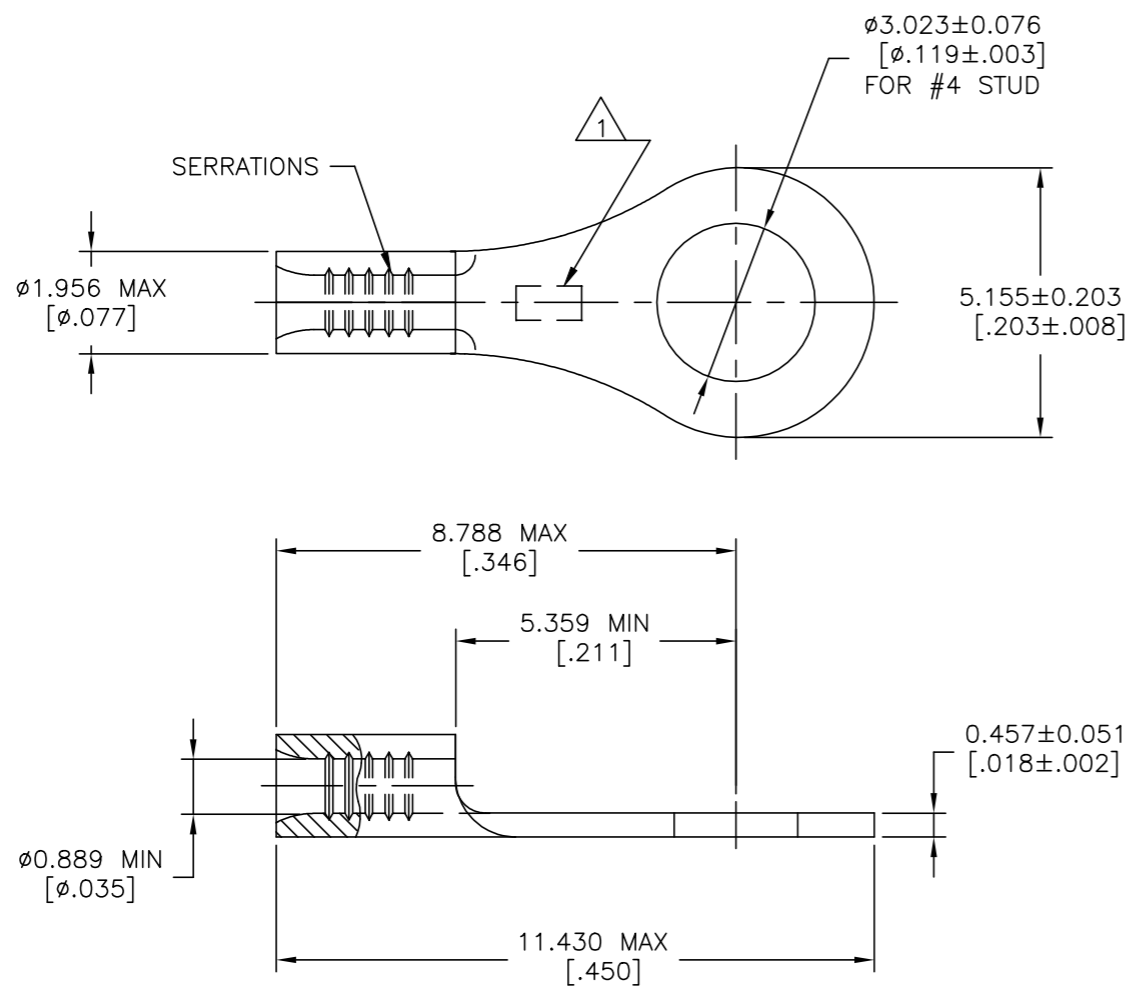

- 1 STAMP AMP APPROX AS SHOWN
- 2 CLEANED, UNPLATED
- 3 TIN PLATE 0.00254[.000100]
MIN EXT THK PER ASTM B545

5000	TAPE & REEL	3	31428-2
1000	LOOSE PIECE	2	31428-1
1000	LOOSE PIECE	3	31428
QTY	PACKAGE TYPE	FINISH	PART NO

AMP INCORPORATED CUSTOMER SERVICE SYSTEMS		MAX RECOMMENDED OPERATING TEMPERATURE: 170° C [338°F] MAX
FOR ADDITIONAL PRODUCT INFORMATION OR COPIES OF DRAWINGS AND TECHNICAL DOCUMENTS	PRODUCT INFORMATION CENTER 1-800-522-6752	VOLTAGE RATING: NOT APPLICABLE
FOR APPLICATION TOOLING INFORMATION	TOOLING ASSISTANCE CENTER 1-800-722-1111	WIRE CROSS SECTIONAL AREA RANGE: 0.1-0.41mm ² [202-810] CIR MILS STRANDED
FOR ORDER ENTRY	1-800-526-5142	

THIS DRAWING IS A CONTROLLED DOCUMENT.		DWN TA BRINKMAN 2-2-93	TE Connectivity Ltd.	
DIMENSIONS: mm [INCHES]		CHK DA PATTERSON 2-2-93	NAME DE MILLER	
TOLERANCES UNLESS OTHERWISE SPECIFIED: 0 PLC ± - 1 PLC ± - 2 PLC ± - 3 PLC ± 0.127[.005] 4 PLC ± - ANGLES ± -		APVD DE MILLER 2-2-93	PRODUCT SPEC APPLICATION SPEC	
MATERIAL COPPER PER ASTM B-152 ANNEALED		FINISH -3	WEIGHT A2 00779	DRAWING NO C=31428
		CUSTOMER DRAWING	RESTRICTED TO -	SCALE 10:1 SHEET 1 OF 1 REV D4