

© COPYRIGHT 1976 BY AMP INCORPORATED, HARRISBURG, PA. ALL INTERNATIONAL RIGHTS RESERVED. AMP INCORPORATED PRODUCTS COVERED BY U. S. AND FOREIGN PATENTS AND/OR PATENTS PENDING.

UNPUBLISHED COPY NOT TO BE REPRODUCED NOR PUBLISHED WITHOUT WRITTEN PERMISSION OF AMP INCORPORATED.

REVISIONS						
P	F	ZONE	LTR	DESCRIPTION	DATE	APPROVED
			G	REVISED & REDRAWN DS	11-17-76	<i>m/k</i>
			H	REVISED PER OH14-0192-05	1-06	PY

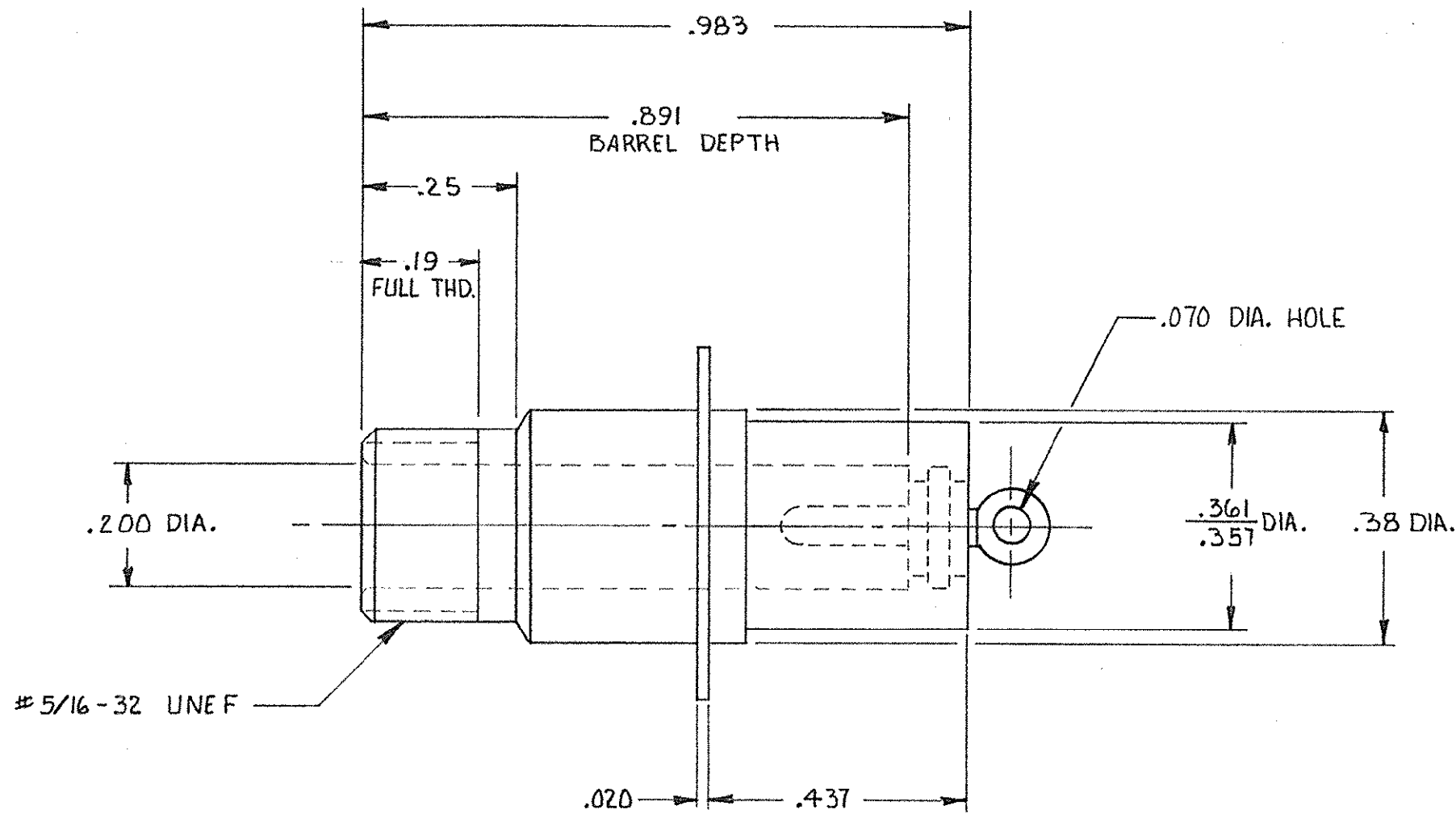
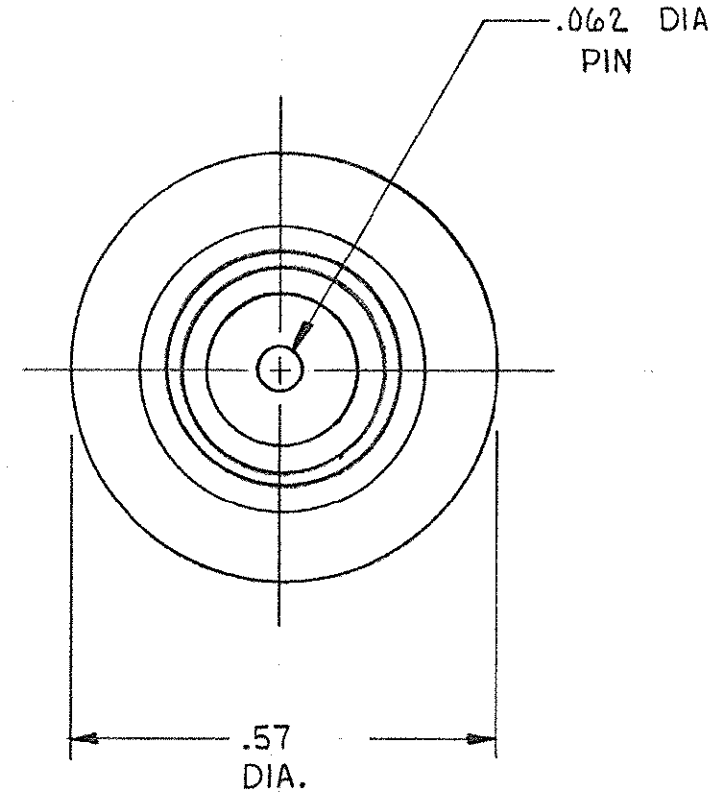

NOTE:
 1. THIS UNIT IS HERMETICALLY SEALED.
 2. SCREW THREAD MEASUREMENT IN ACCORDANCE WITH H-28 HANDBOOK. (3 WIRE METHOD). USING WIRE .01804 DIA. MEASUREMENT OVER WIRE SHALL BE .318 / .307.

5-861253-1	AS SHOWN WITH TIN PLATED PIN & FLANGE
861253-1	AS SHOWN WITH TIN-LEAD PLATED PIN & FLANGE

				UNLESS OTHERWISE SPECIFIED DIMENSIONS ARE IN INCHES. TOLERANCES: .00 ± .01 .000 ± .005 ANGLES ±		CONTRACT NO		 AMP INCORPORATED Elizabethtown, Pa.	
				MATERIAL MOLDED GLASS EPOXY		DR DICK STONE 11-17-76			
				FINISH BLACK		CHK		DRAWING NO 861253	
						APPD <i>M. Gordon</i> 11/17/76		CODE IDENT NO 00779	
						APPD		SCALE	
						DSGN APPD		SHEET 1 OF 1	
						OTHER APPD			
NEXT ASSY		FINAL ASSY		NEXT ASSY		USED ON			
QTY REQD		APPLICATION							