

THIS DRAWING IS UNPUBLISHED. RELEASED FOR PUBLICATION
 © COPYRIGHT - By - ALL RIGHTS RESERVED.

LOC		DIST		REVISIONS			
P	LTR	DESCRIPTION	DATE	DWN	APVD		
	J	REV PER ECO 14-014240	10-1-14	CT	CD		

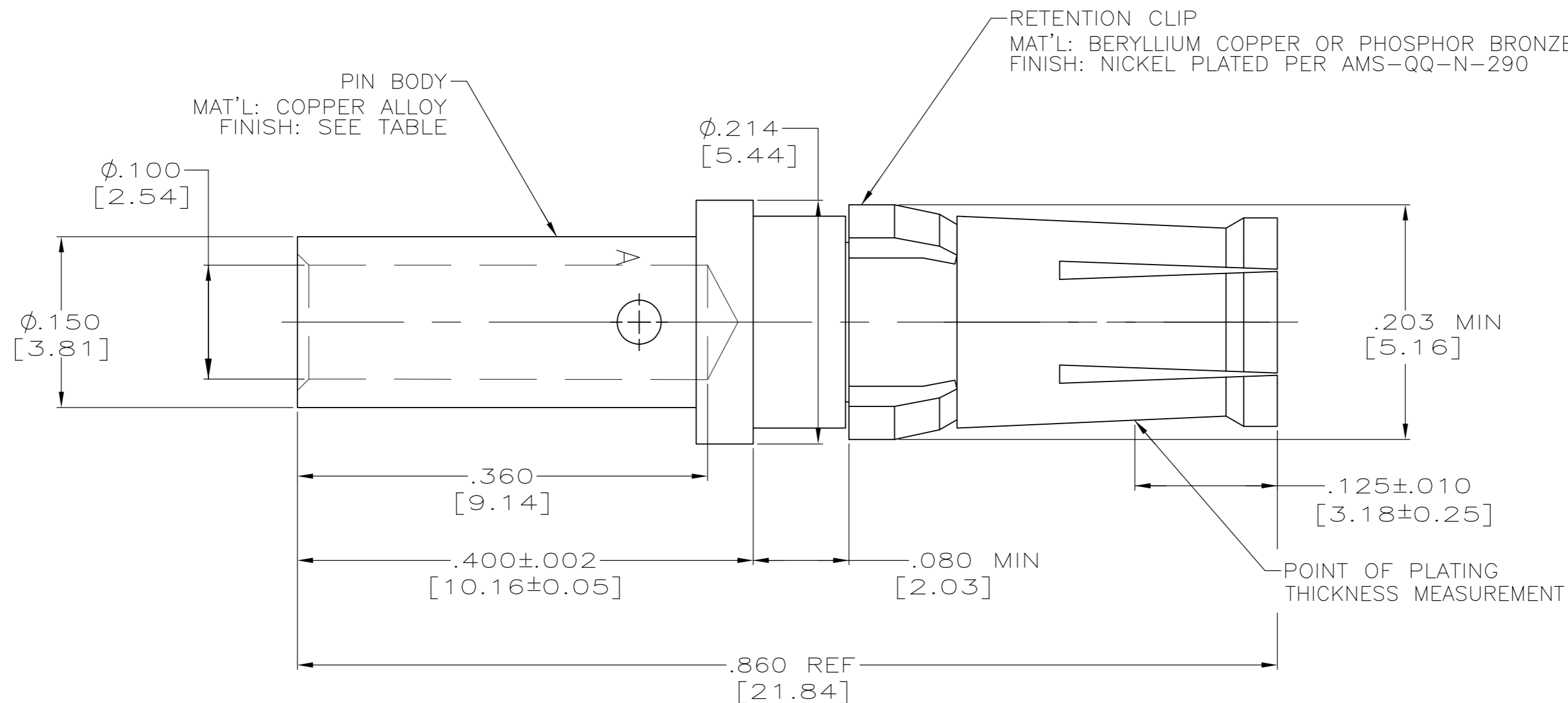

- THIS PART CONFORMS TO REQUIREMENTS FOR DANIELS CRIMP TOOL NO. M300-BT, WITH DANIELS POSITIONER PART NO. SP689, STRIP LENGTH .375, SETTING #1.
- MATES WITH 212007-1 IN AMPLIMITE CONNECTOR ASSEMBLIES ONLY.
- $\triangle 3$ FINISH: PLATED GOLD .000050 [0.00127] MIN THK PER ASTM-B0488 OVER NICKEL .000050 [0.00127] MIN THK PER AMS-QQ-N-290.
- $\triangle 4$ FINISH: PLATED GOLD .000030 [0.00076] MIN THK PER ASTM-B0488 OVER NICKEL .000050 [0.00127] MIN THK PER AMS-QQ-N-290.
- WIRE BARREL WILL ACCEPT #12-#14 AWG WIRE.
- $\triangle 6$ RESTRICTED PART NUMBER.

PRELIMINARY NOT RELEASED FOR PRODUCTION	$\triangle 6$	1-212008-1
	$\triangle 4$	212008-2
	$\triangle 3$	212008-1
	FINISH	PART NUMBER

THIS DRAWING IS A CONTROLLED DOCUMENT.		DWN	C.C.THOMAS	11/10/00	 TE Connectivity
DIMENSIONS: INCHES[MM]		CHK	D.MILLER	11/10/00	
TOLERANCES UNLESS OTHERWISE SPECIFIED:		APVD	D.MILLER	11/10/00	
0 PLC \pm - 1 PLC \pm - 2 PLC \pm - 3 PLC \pm .005 [0.13] 4 PLC \pm - ANGLES \pm - FINISH SEE TABLE		PRODUCT SPEC	108-10045	NAME	
MATERIAL SEE CALLOUTS		APPLICATION SPEC	114-10014	SIZE	A2
		WEIGHT	-	CAGE CODE	00779
		CUSTOMER DRAWING		DRAWING NO	C-212008
		SCALE	10:1	SHEET	1 of 1
		REV	J	RESTRICTED TO	