

DRAWING MADE IN THIRD ANGLE PROJECTION

THIS DRAWING IS UNPUBLISHED. RELEASED FOR PUBLICATION
 © COPYRIGHT 19 BY AMP INCORPORATED, HARRISBURG, PA. ALL INTERNATIONAL RIGHTS RESERVED. AMP PRODUCTS MAY BE COVERED BY U.S. AND FOREIGN PATENTS AND/OR PATENTS PENDING.

LOC		DIST		REVISIONS				
AF	50	P	F	ZONE	LTR	DESCRIPTION	DATE	APPROVED
				G		REVISED AF-7659	10/17/81	

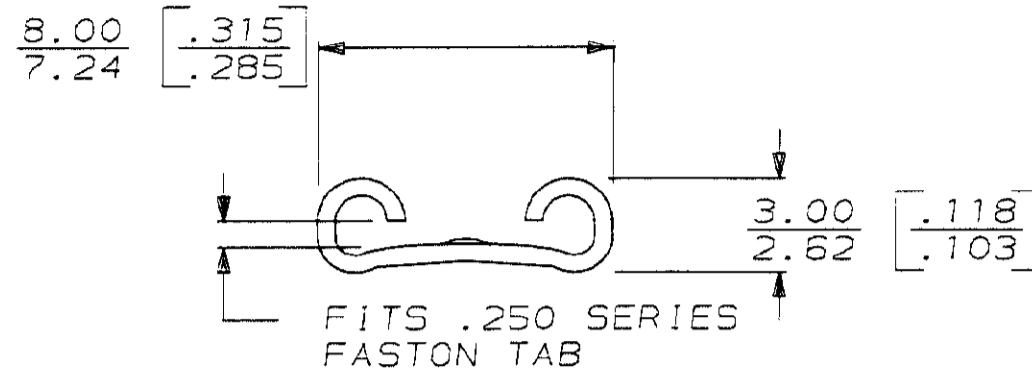
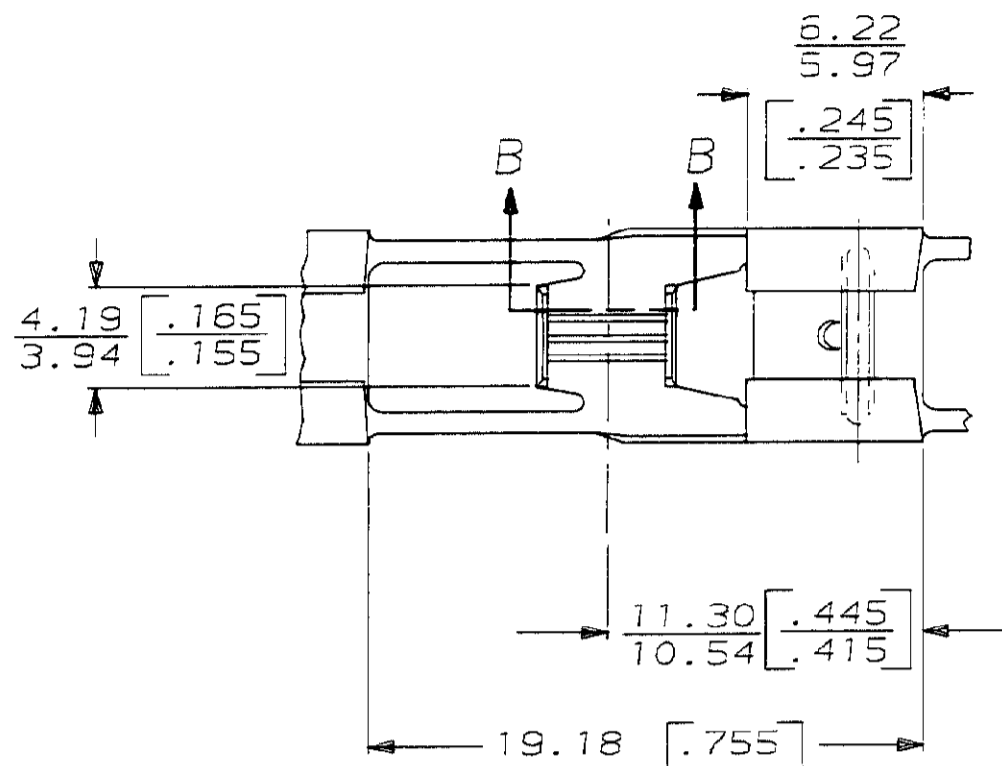

VIEW A-A

1- DIMENSIONS IN BRACKETS ARE IN INCHES.
 2- CONTINUOUS STRIP ON REELS.

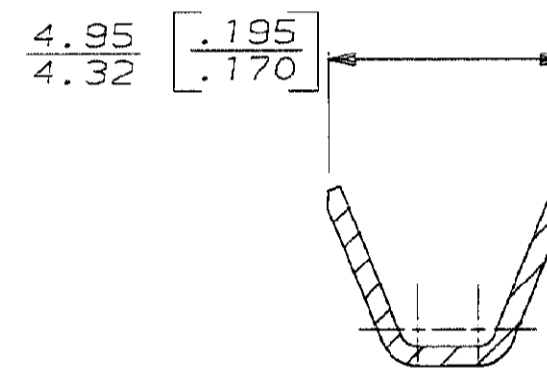
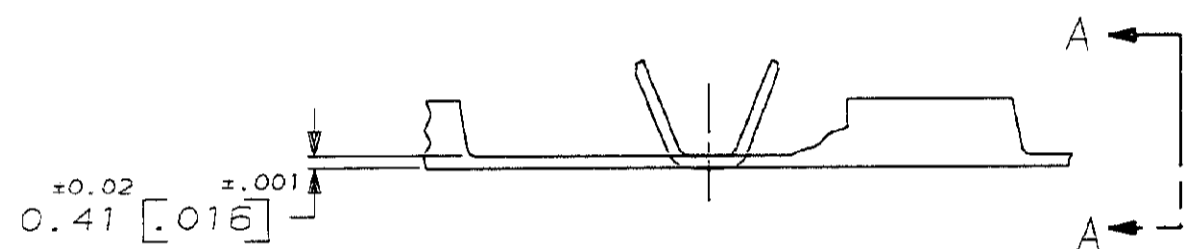

SECTION B-B

PART NO.	WIRE		WIRE BARREL CRIMP			TENSILE STRENGTH POUNDS
	QTY	SIZE AWG	WIDTH	CRIMP HEIGHT	CRIMPER ANVIL	
63315-1	1	14	.120	.071	F FLAT	50
	1	16		.063		30
	1	18		.057		20

FINISH	WIRE SIZE	TAB THK	PART NO
TIN	0.8-2.0mm ² [18-14]	.081 ±0.025 [.032 ±.001]	63315-2
	0.8-2.0mm ² [18-14]	.081 ±0.025 [.032 ±.001]	63315-1

UNLESS OTHERWISE SPECIFIED DIMENSIONS ARE IN MM TOLERANCES ON: 2 PL DEC ± - 3 PL DEC ± 0.25 [.010] ANGLES ± -	DR	LR Ruth	6/16/87
	CHK	G YETTER	6/17/87
	APPD	C MEYERS	6/17/87
	APPD	R KUZO	6/17/87
MATERIAL	4M BRASS		
FINISH	SEE TABLE		
PRODUCT SPEC	-		
APPLICATION SPEC	-		
WEIGHT	-		

AMP AMP INCORPORATED Harrisburg, Pa. 17105	
NAME RECEPTACLE, FASTON, FLAG, .250 SERIES	
SIZE C	FSCM NO 00779
DRAWING NO 63315	
SCALE NTS	SHEET 1 OF 1

METRIC