

SPECIFICATION CONTROL DRAWING

7528A1317

CHEMINAX

75 OHM, AWG 28, 7 STRANDS OF AWG 36,
COAXIAL CABLE

Date: 3-29-00
Revision: E

THIS SPECIFICATION SHEET FORMS A PART OF THE LATEST ISSUE OF RAYCHEM SPECIFICATION 1200.

CONSTRUCTION DETAILS

ELECTRICAL CHARACTERISTICS

DIMENSIONS ARE NOMINAL VALUES IN INCHES UNLESS OTHERWISE DESIGNATED.

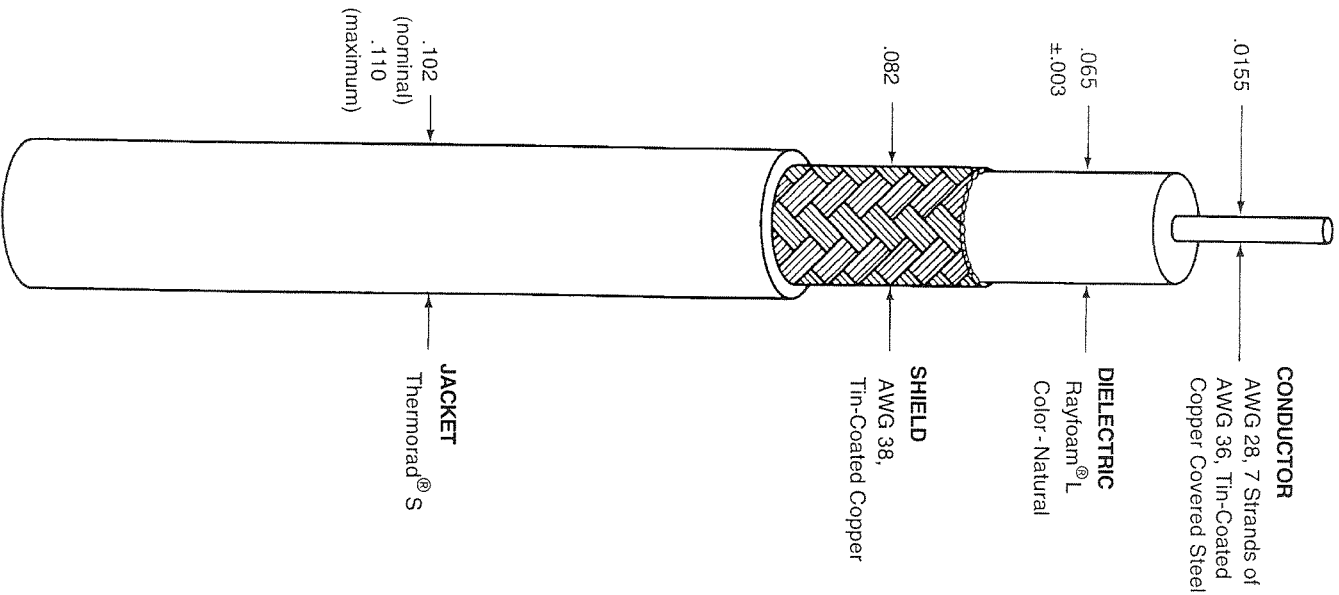

CHARACTERISTIC IMPEDANCE	75 ± 3 ohms, Method B
CAPACITANCE	17.6 pF/ft. (nominal)
VELOCITY OF PROPAGATION	77% (nominal)

ADDITIONAL REQUIREMENTS

ELECTRICAL	
CONDUCTOR RESISTANCE	162 ohms/1000 ft. (nominal)
INSULATION RESISTANCE	10,000 megohms (minimum) for 1000 ft.
JACKET FLAWS	
SPARK TEST	1.0 kV (rms), 60 Hz
IMPULSE TEST	6.0 kV (peak)
VOLTAGE WITHSTAND (DIELECTRIC)	1000 volts (rms), (minimum)

ENVIRONMENTAL	
AGING STABILITY	135°C/-55°C/2.75 inch mandrel
FLAMMABILITY	Method C
HEAT SHOCK	225°C
LOW TEMPERATURE- COLD BEND	-55°C/2.75 inch mandrel
VOLTAGE WITHSTAND (POST ENVIRONMENTAL)	1000 volts (rms), for 1 minute

PHYSICAL	
INSULATION (DIELECTRIC)	
ELONGATION	50% (minimum)
TENSILE STRENGTH	800 lbf/in ² (minimum)
JACKET	
ELONGATION	250% (minimum)
TENSILE STRENGTH	2000 lbf/in ² (minimum)
JACKET THICKNESS	.010 inch (nominal)
SHIELD COVERAGE	90% (minimum)

WEIGHT	6.9 lbs/1000 ft. (nominal)
--------	----------------------------

Outer jacket color will be black (designated by a "0" appended to the part number, e.g., 7528A1317-0) unless otherwise specified.

Designate outer jacket color with a dash number in accordance with MIL-STD-681.

Raychem

300 Constitution Drive
Menlo Park, California 94025
1-800-2-Raychem FAX: 1-415-361-6297

THIS SPECIFICATION SHEET TAKES PRECEDENCE OVER DOCUMENTS REFERENCED HEREIN. REFERENCE DOCUMENTS SHALL BE OF THE ISSUE IN EFFECT ON DATE OF INVITATION FOR BID.