

PART NUMBER	REVISION	DESCRIPTION	FEED TYPE
2266736-1	F	FINE CRIMP HEIGHT ADJUST	MECHANICAL
2266736-2	G	FINE CRIMP HEIGHT ADJUST	PNEUMATIC
7-2266736-1	F	MECHANICAL AND CRIMP TOOLING KIT	MECHANICAL
7-2266736-2	G	PNEUMATIC AND CRIMP TOOLING KIT	PNEUMATIC
7-2266736-7	C	CRIMP TOOLING KIT	-

ATLANTIC VERSION TERMINATOR INTERFACE ADAPTER



APPLICATOR DATA		
CRIMP	SIZE	TYPE
WIRE	1.57 mm [1.062]	F
INSUL	-	-

APPLICATOR INSTRUCTIONS
408-35042

TERMINAL DATA: TE TERMINAL TE CRIMP SPECIFICATION			
TERMINAL NAME: SOCKET CONTACT, PLUG, SMB			
WIRE STRIP LENGTH		INSULATION DIAMETER RANGE	
TERMINAL APPLICATION SPECIFICATION	114-13157	-	-
TERMINALS APPLIED			
TE TERMINAL	TE TERMINAL	TE TERMINAL	TE TERMINAL
2203232-2	1438890-7	1438896-2	

WIRE SIZE	CRIMP HEIGHT mm [INCH]	CRIMP HEIGHT REFERENCE SETTING
RG-58 LL or RG-58	0.86+/-0.05 [1.034+/-0.002]	5.2
2DS-PPFW(TA)	0.86+/-0.05 [1.034+/-0.002]	5.2

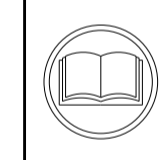

- 1 RECOMMENDED SPARE PARTS
- 2 REFER TO SUPPLIED INSTRUCTION SHEET FOR CLEANING, LUBRICATION AND STORAGE OF APPLICATOR.
- 3 CRIMP HEIGHT REFERENCE SETTING WAS THE SETTING USED WHEN THE APPLICATOR WAS QUALIFIED AT THE FACTORY. ADJUSTMENT MAY BE NECESSARY WHEN RUNNING APPLICATOR IN THE FIELD.
- 4 TERMINAL LUBRICANT IS RECOMMENDED.
- 5. UNLESS SPECIFIED OTHERWISE TORQUE VALUES SHALL BE USED PER DOCUMENT, 101-35000.
- 6 SEE TERMINAL APPLICATION SPEC 114-13157 FOR WIRE STRIP LENGTH.
- 7. THIS APPLICATOR IS DESIGNED FOR BENCH APPLICATORS ONLY.
- 8 GRIND AT ASSEMBLY

***WARNING**
ON INSTALLATION, SET WIRE DISC TO CRIMP HEIGHT REFERENCE SETTING FOR LARGEST WIRE SIZE. CRIMP HEIGHT REFERENCE SETTINGS GREATER THAN THE VALUE SHOWN MAY CAUSE DAMAGE TO THE CRIMP TOOLING. REFER TO THE INSTRUCTION SHEET FOR PROPER SETUP AND ADJUSTMENTS.

LOC	DIST	REVISIONS					
		P	LTN	DESCRIPTION	DATE	OWN	APVD
A	66	E		ECR-17-001243	26JAN2017	TB	TE
		E1		ECR-17-015143	12OCT2017	JAH	TE
		F		ECR-00-007800	22MAY2018	TB	JDG
		G		ECR-19-008911	06JUN2019	FJ	TE

-	1	-	1	-	2119641-1	FEED CAM, AIR FEED	248
-	-	1	-	1	2119580-1	MECHANICAL FEED ASSEMBLY	239
-	1	-	1	-	2844940-1	AIR FEED MODULE	238
-	REF	REF	REF	REF	994970-2	COUNTER, MAGNETIC	164
4	-	1	1	1	2119955-1	ASSY, LUBRICATOR, SIDE FEED	113
-	1	1	1	1	2844908-1	SCREW, LOCKING	99
-	1	1	1	1	2844907-1	POST, LOCKING	98
-	1	1	1	1	455888-8	SPACER, CRIMPER	82
-	1	1	1	1	1803607-3	DOCUMENTATION PACKAGE	71
-	1	1	1	1	2119740-1	TAG, IDENTIFICATION	67
-	2	2	2	2	2168078-1	SCREW, DRIVE, RH, RoHS, 2 x .188	66
-	1	1	1	1	2168083-2	SCR, SKT HD CAP, RoHS, M4 X 8.0	60
-	1	1	1	1	5-18022-5	SCR, HEX HD CAP, M4 X 6.0	59
-	1	1	1	1	1338685-1	PAWL, FEED	56
-	4	4	4	4	2168083-3	SCR, SKT HD CAP, RoHS, M4 X 12.0	54
-	2	2	2	2	1-2168083-0	SCR, SKT HD CAP, RoHS, M4 X 10	53
-	1	1	1	1	5018030-1	NUT, HEX, REG, RoHS, M3	52
8	-	1	1	1	811242-5	BUMPER, HOLD DOWN	51
-	1	1	1	1	690753-2	SPACER, TONKER	50
-	1	2	1	2	18023-9	SCR, SKT HD CAP M4 X 6.0	49
-	-	1	-	1	2119652-1	FEED CAM, PRE FEED	48
-	-	1	-	1	2119653-1	FEED CAM, POST FEED	47
-	1	1	1	1	1803583-9	APPLICATOR BASIC ASSEMBLY, SF	46
-	1	1	1	1	1803515-1	RAM ASSEMBLY, SF ATLANTIC	44
-	1	1	1	1	1803602-1	SCR, BHSC, RoHS (M8 X 25)	41
-	1	1	1	1	1-1752356-9	SUPPORT, TERMINAL	34
-	2	2	2	2	2079383-5	SCR, BHSC, RoHS (M4 X 20)	33
-	2	2	2	2	2-2844962-4	SPACER, CYLINDRICAL, STRIP GUIDE	30
-	1	1	1	1	2844992-1	ASSEMBLY, STRIP GUIDE	29
-	1	1	1	1	455888-3	SPACER, CRIMPER	28
-	1	1	1	1	1320928-2	STRIP GUIDE	24
-	1	1	1	1	3-22280-3	SPRING, COMPRESSION	12
-	1	1	1	1	356885-5	STOP, SHEAR	11
1	1	1	1	1	1803216-1	HOLDER, SHEAR	10
1	1	1	1	1	1338293-7	SHEAR, FLOATING	9
1	2	2	1	1	6-1633933-4	ANVIL, COMBINATION	8
-	-	-	-	-	-	-	7
-	-	-	-	-	-	-	6
-	1	1	1	1	1803419-5	DEPRESSOR, SHEAR	5
-	-	-	-	-	-	-	4
-	-	-	-	-	-	-	3
-	-	-	-	-	-	-	2
1	2	2	1	1	4-456403-6	CRIMPER, WIRE PREMIUM	1
-77	-72	-71	-2	-1	PART NO	DESCRIPTION	ITEM NO

ATLANTIC VERSION
Shown on sheets 1 of 4 & 2 of 4
(Pacific version shown on sheets 3 of 4 & 4 of 4)

DIMENSIONS:		TOLERANCES UNLESS OTHERWISE SPECIFIED:		OWN Y. YIN 30MAR2015	TE Connectivity	
mm	0 PLC ±	1 PLC ±	2 PLC ±	CHK G. BAILEY 30MAR2015	Harrisburg, PA 17105-3608	
	3 PLC ±	4 PLC ±	ANGLES ±	APVD JJ. GUO 30MAR2015	NAME Ocean Side Feed Applicator	
MATERIAL	FINISH	WEIGHT	SCALE	SIZE CAGE CODE DRAWING NO	RESTRICTED TO	
			1:2	A1 00779 C=2266736	Customer Accessible Production Drawing	SCALE 1:2 SHEET 1 OF 4 REV G

LOC		DIST		REVISIONS			
A	66	P	LTM	DESCRIPTION	DATE	DWN	APVD
		-		SEE SHEET 1			

FEED TYPE MECHANICAL

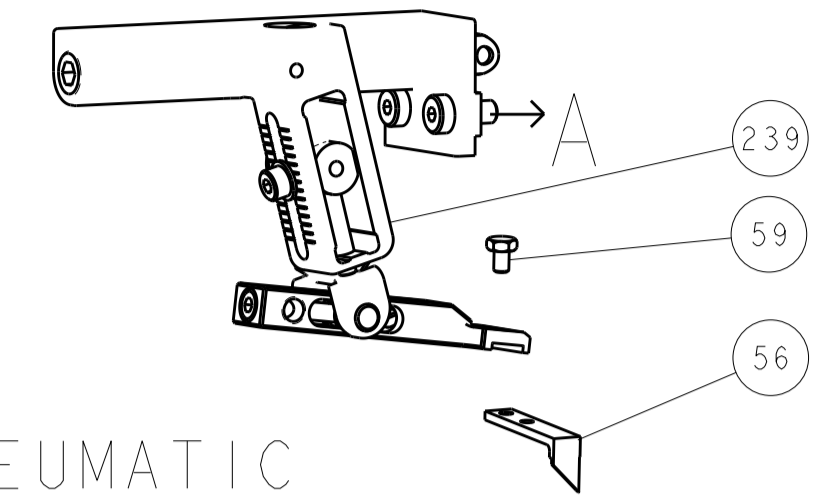

PNEUMATIC

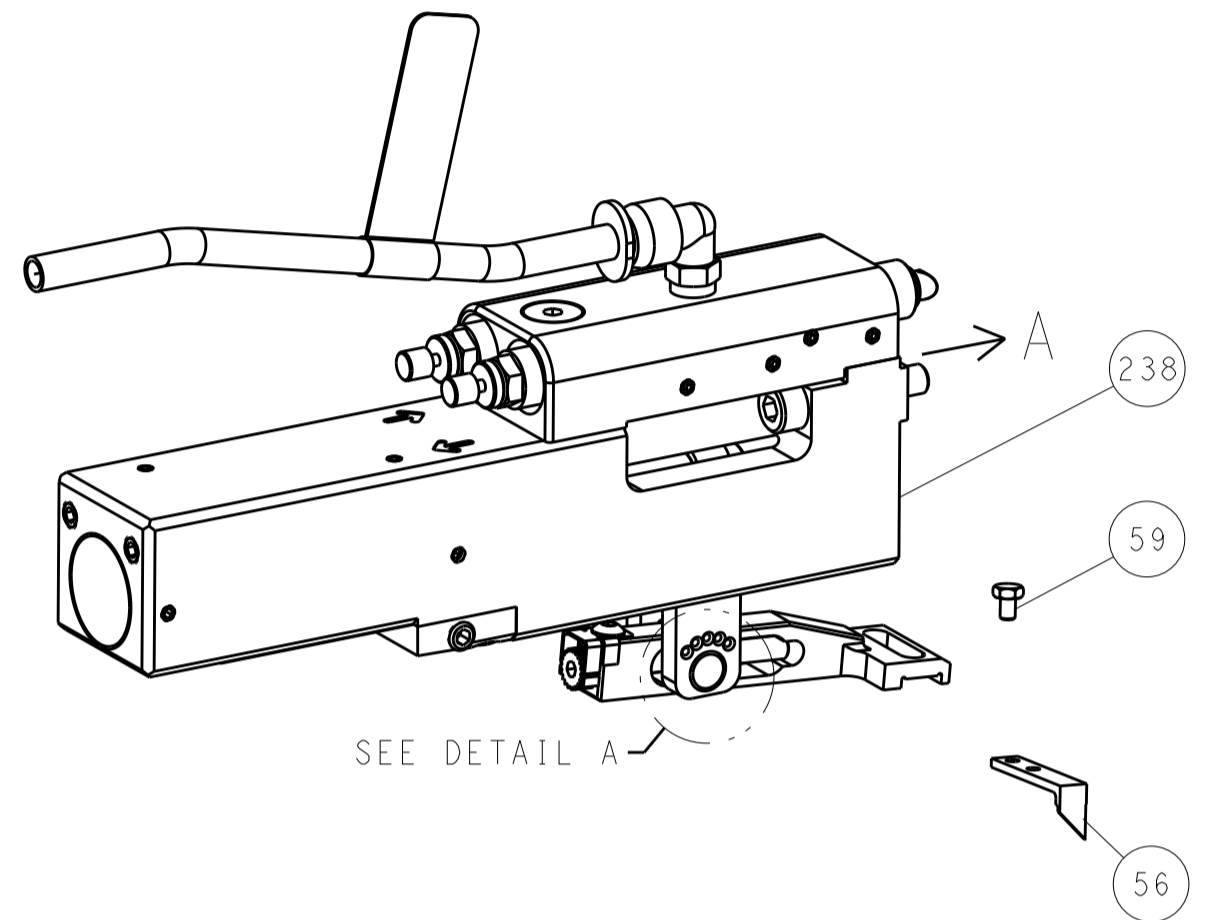

FEED SPRING SETTING POSITION (SHOWN FROM REAR SIDE)

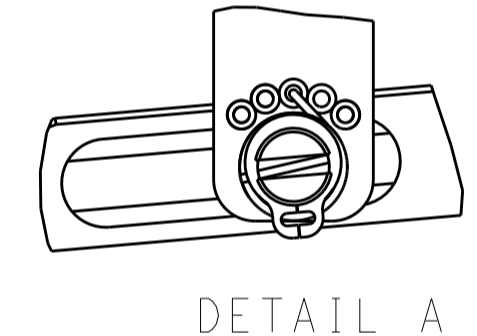

DETAIL A

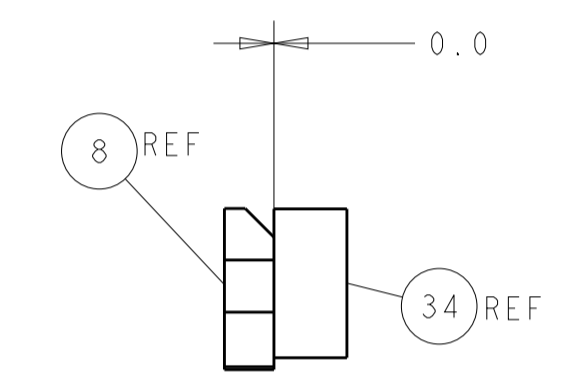
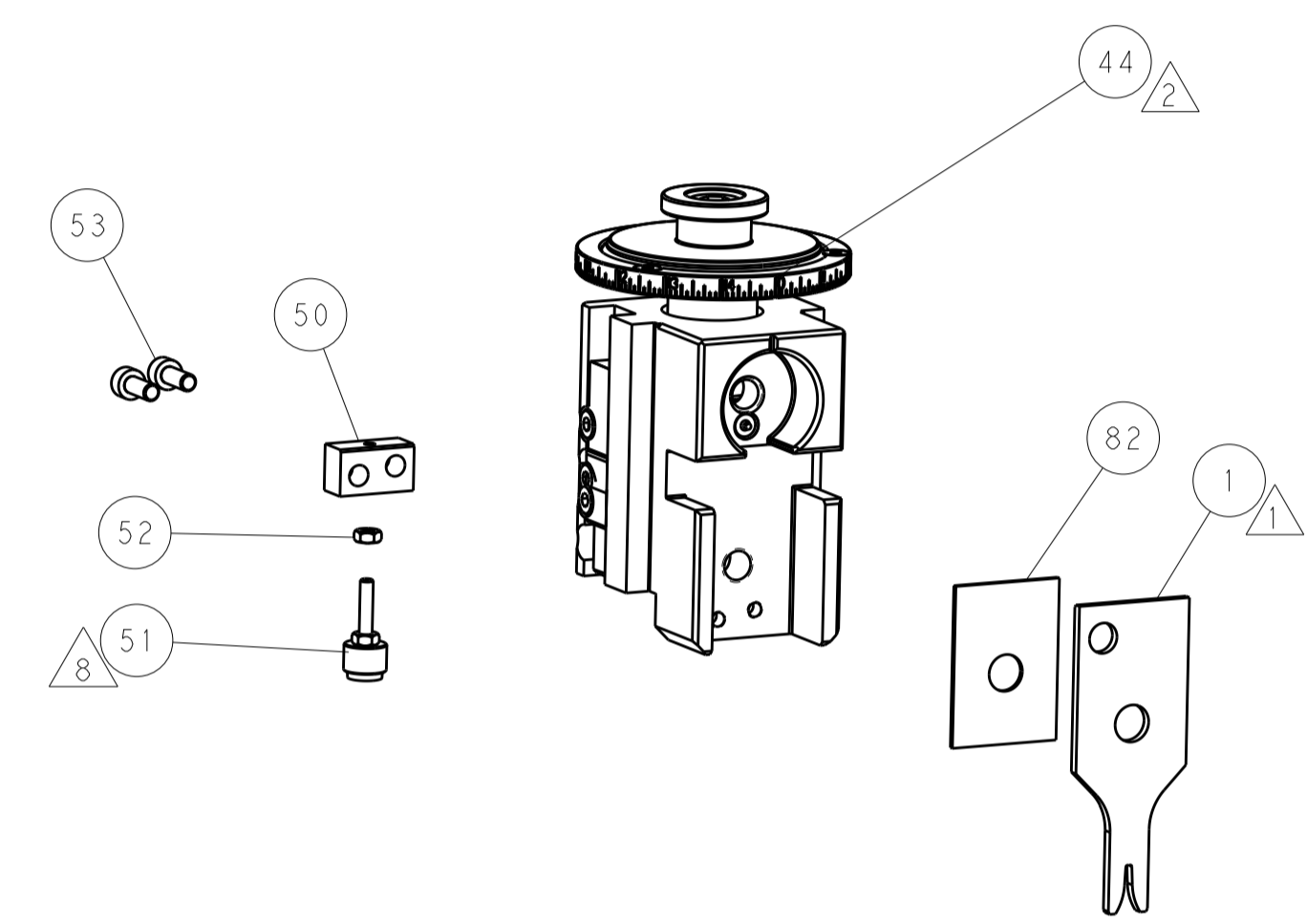

TERMINAL SUPPORT LOCATION

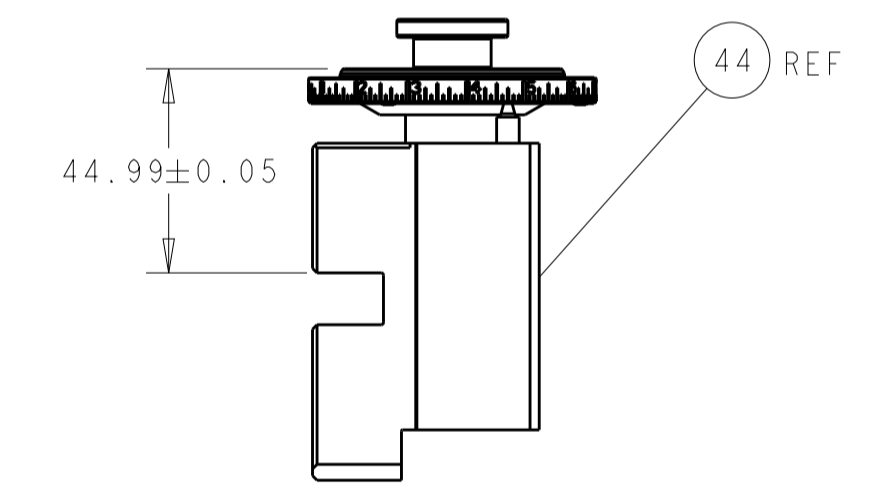
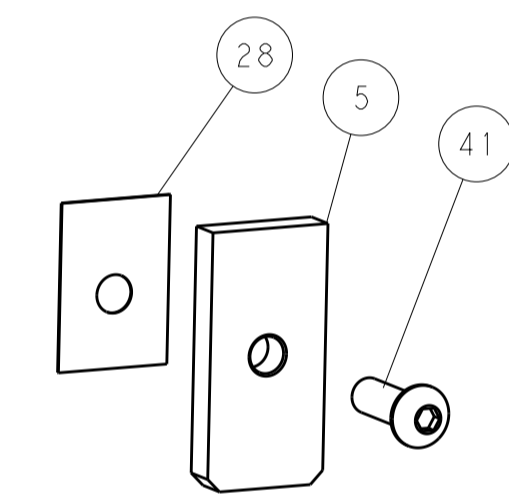

RAM SET-UP

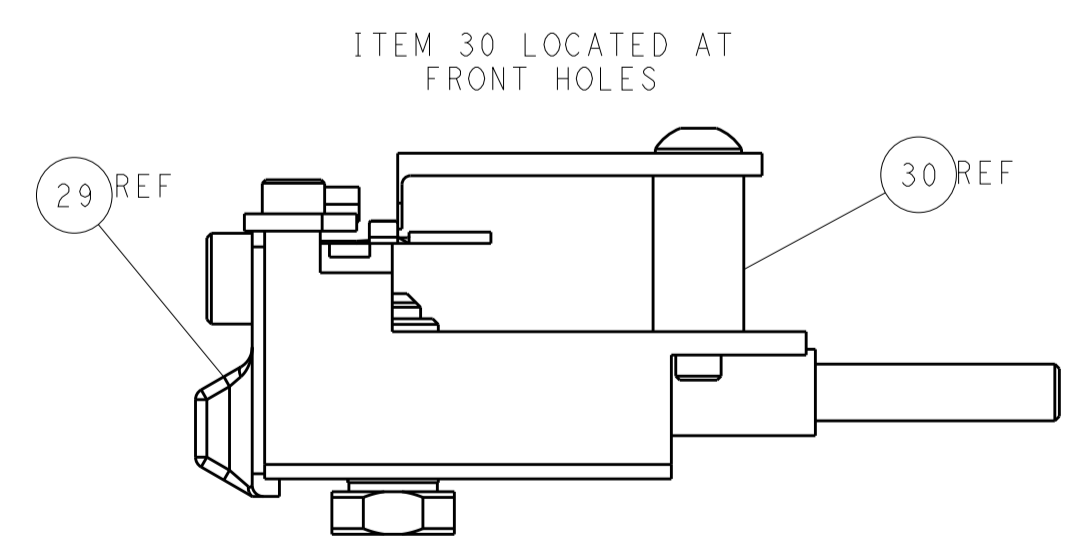
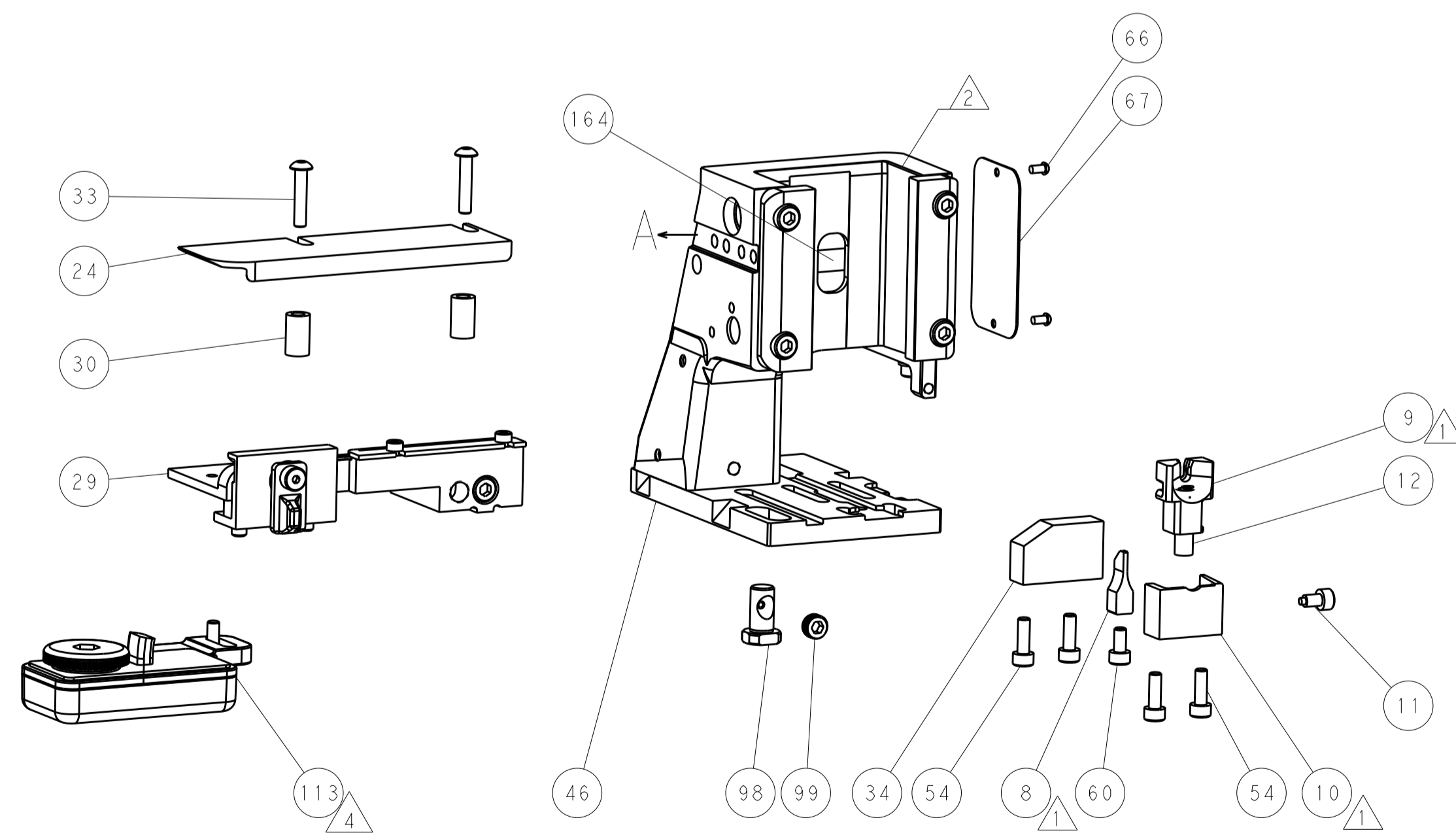

FEED TRACK POSITION GUIDE BY WIRE BARREL

CAM POSITIONS

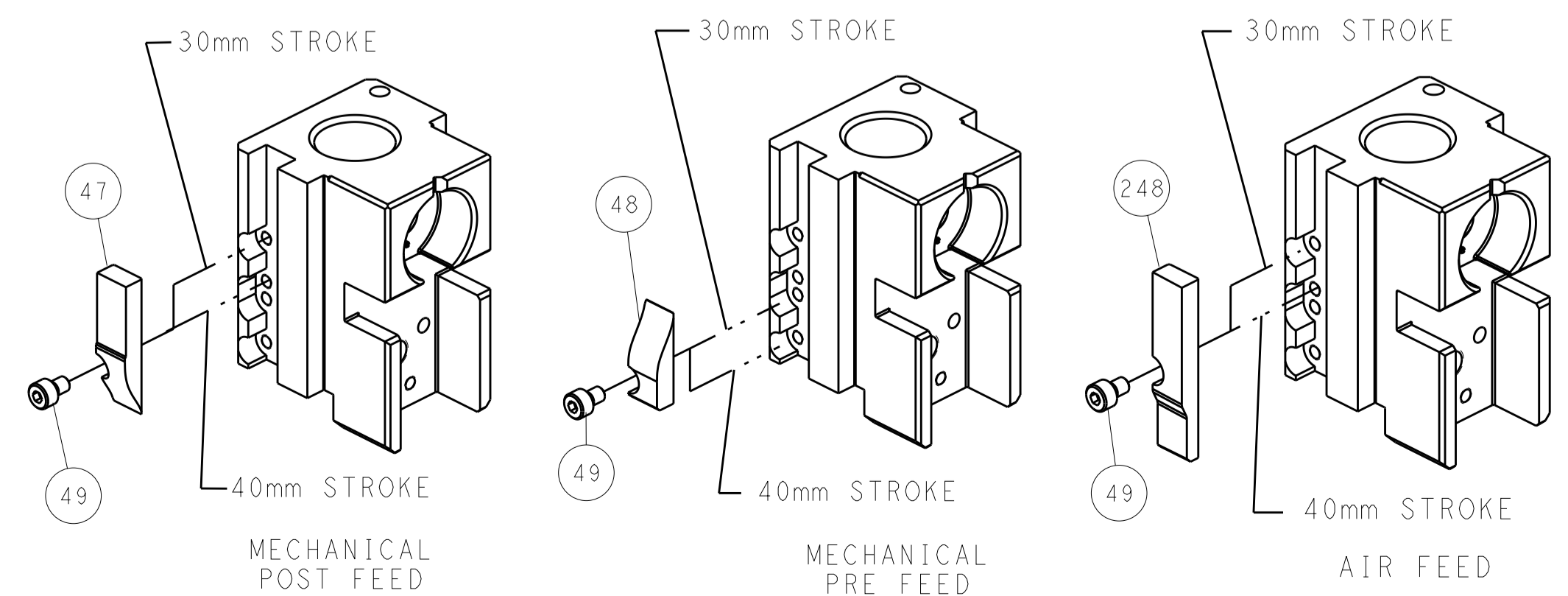

ATLANTIC VERSION
 Shown on sheets 1 of 4 & 2 of 4
 (Pacific version shown on sheets 3 of 4 & 4 of 4)

DIMENSIONS:		TOLERANCES UNLESS OTHERWISE SPECIFIED:		DWN Y. YIN 30MAR2015		TE Connectivity	
mm	0 PLC ±	1 PLC ±	2 PLC ±	3 PLC ±	4 PLC ±	Harrisburg, PA 17105-3608	
MATERIAL:		FINISH:		CHK G. BAILEY 30MAR2015		NAME Ocean Side Feed Applicator	
				APVD H. GUO 30MAR2015		SIZE CAGE CODE DRAWING NO RESTRICTED TO	
				PRODUCT SPEC		A1 00779 C=2266736	
				APPLICATION SPEC		Customer Accessible Production Drawing	
				WEIGHT		SCALE 1:2 SHEET 2 OF 4 REV G	

PART NUMBER	REVISION	DESCRIPTION	FEED TYPE
2-2266736-1	F	FINE CRIMP HEIGHT ADJUST	MECHANICAL
2-2266736-2	G	FINE CRIMP HEIGHT ADJUST	PNEUMATIC
7-2266736-7	C	CRIMP TOOLING KIT	-

PACIFIC VERSION TERMINATOR
INTERFACE ADAPTER



APPLICATOR DATA		
CRIMP	SIZE	TYPE
WIRE	1.57 mm [.062]	F
INSUL	-	-

APPLICATOR INSTRUCTIONS
408-35042

TERMINAL DATA: TE TERMINAL		TE CRIMP SPECIFICATION	
TERMINAL NAME: SOCKET CONTACT, PLUG, SMB			
WIRE STRIP LENGTH		INSULATION DIAMETER RANGE	
TERMINAL APPLICATION SPECIFICATION	114-13157	-	-
TERMINALS APPLIED			
TE TERMINAL	TE TERMINAL	TE TERMINAL	TE TERMINAL
2203232-2	1438890-7	1438896-2	

WIRE SIZE	CRIMP HEIGHT mm [INCH]	CRIMP HEIGHT REFERENCE SETTING
RG-58 LL or RG-58	0.86 +/- 0.05 [.034 +/- .002]	5.2
2DS-PPFW(TA)	0.86 +/- 0.05 [.034 +/- .002]	5.2

- RECOMMENDED SPARE PARTS
- REFER TO SUPPLIED INSTRUCTION SHEET FOR CLEANING, LUBRICATION AND STORAGE OF APPLICATOR.
- CRIMP HEIGHT REFERENCE SETTING WAS THE SETTING USED WHEN THE APPLICATOR WAS QUALIFIED AT THE FACTORY. ADJUSTMENT MAY BE NECESSARY WHEN RUNNING APPLICATOR IN THE FIELD.
- TERMINAL LUBRICANT IS RECOMMENDED.
- 5. UNLESS SPECIFIED OTHERWISE TORQUE VALUES SHALL BE USED PER DOCUMENT, 101-35000.
- SEE TERMINAL APPLICATION SPEC 114-13157 FOR WIRE STRIP LENGTH.
- 7. THIS APPLICATOR IS DESIGNED FOR BENCH APPLICATORS ONLY.
- GRIND AT ASSEMBLY

***WARNING**
ON INSTALLATION, SET WIRE DISC TO CRIMP HEIGHT REFERENCE SETTING FOR LARGEST WIRE SIZE. CRIMP HEIGHT REFERENCE SETTINGS GREATER THAN THE VALUE SHOWN MAY CAUSE DAMAGE TO THE CRIMP TOOLING. REFER TO THE INSTRUCTION SHEET FOR PROPER SETUP AND ADJUSTMENTS.

LOC	DIST	REV	DATE	BY	APPD
A	66				

REV	DATE	BY	APPD	DESCRIPTION	ITEM NO
-	-	1		2119580-1 MECHANICAL FEED ASSEMBLY	239
-	1	-		2844940-1 AIR FEED MODULE	238
-	REF	REF		994970-2 COUNTER, MAGNETIC	164
-	1	-		2119641-2 FEED CAM, AIR FEED	151
-	1	1		2168083-8 SCR, SKT HD CAP, RoHS, M4 X 16	144
-	4	4		2168083-9 SCR, SKT HD CAP, RoHS, M4 X 20	143
-	-	1		2119653-2 FEED CAM, POST FEED	142
-	1	1		1-1803583-0 APPLICATOR BASIC ASSEMBLY, SF	141
-	1	1		1803516-1 RAM ASSEMBLY, SF PACIFIC	140
	1	1		2119955-1 ASSY, LUBRICATOR, SIDE FEED	113
-	1	1		2844908-1 SCREW, LOCKING	99
-	1	1		2844907-1 POST, LOCKING	98
-	1	1		455888-8 SPACER, CRIMPER	82
-	1	1		1803607-3 DOCUMENTATION PACKAGE	71
-	1	1		2119740-1 TAG, IDENTIFICATION	67
-	2	2		2168078-1 SCREW, DRIVE, RH, RoHS, 2 x .188	66
-	1	1		5-18022-5 SCR, HEX HD CAP, M4 X 6.0	59
-	1	1		1338685-1 PAWL, FEED	56
-	2	2		1-2168083-0 SCR, SKT HD CAP, RoHS, M4 X 10	53
	1	1		5018030-1 NUT, HEX, REG, RoHS, M3	52
	1	1		811242-5 BUMPER, HOLD DOWN	51
	1	1		690753-2 SPACER, TONKER	50
-	1	2		18023-9 SCR, SKT HD CAP M4 X 6.0	49
-	-	1		2119652-1 FEED CAM, PRE FEED	48
-	1	1		1803602-1 SCR, BHSC, RoHS (M8 X 25)	41
-	1	1		1-1752356-9 SUPPORT, TERMINAL	34
-	2	2		2079383-5 SCR, BHSC, RoHS (M4 X 20)	33
-	2	2		2-2844962-4 SPACER, CYLINDRICAL, STRIP GUIDE	30
-	1	1		2844992-1 ASSEMBLY, STRIP GUIDE	29
-	1	1		455888-3 SPACER, CRIMPER	28
-	1	1		1320928-2 STRIP GUIDE	24
-	1	1		1-18028-2 WASHER, FLAT, REG M4	20
-	1	1		3-22280-3 SPRING, COMPRESSION	12
-	1	1		356885-5 STOP, SHEAR	11
	1	1		1803216-1 HOLDER, SHEAR	10
	1	1		1338293-7 SHEAR, FLOATING	9
	1	1		6-1633933-4 ANVIL, COMBINATION	8
-	-	-		-	7
-	-	-		-	6
-	1	1		1803419-5 DEPRESSOR, SHEAR	5
-	-	-		-	4
-	-	-		-	3
-	-	-		-	2
	1	1		4-456403-6 CRIMPER, WIRE PREMIUM	1

PACIFIC VERSION
Shown on sheets 3 of 4 & 4 of 4
(Atlantic version shown on sheets 1 of 4 & 2 of 4)

<small>THIS DRAWING IS UNPUBLISHED. IT IS THE PROPERTY OF TYCO ELECTRONICS CORPORATION. ALL RIGHTS RESERVED. IT IS SUBJECT TO CHANGE AND WITHOUT WARRANTY. REVISIONS SHOULD BE CONTACTED FOR THE LATEST REVISION.</small>		DWN Y. YIN 30MAR2015 CHK G. BAILEY 30MAR2015 APVD JJ. GUO 30MAR2015	TE Connectivity Harrisburg, PA 17105-3608
DIMENSIONS: mm 		TOLERANCES UNLESS OTHERWISE SPECIFIED: 0 PLC ± 1 PLC ± 2 PLC ± 3 PLC ± 4 PLC ± ANGLES ± FINISH ±	NAME: Ocean Side Feed Applicator SIZE: A1 CAGE CODE: 00779 DRAWING NO: 2266736 SCALE: 1:2 SHEET: 3 OF 4 REV: G
MATERIAL: - FINISH: -		WEIGHT: - APPLICATION SPEC: - PRODUCT SPEC: -	RESTRICTED TO: - Customer Accessible Production Drawing

LOC	DIST	REVISIONS					
A	66	P	LTN	DESCRIPTION	DATE	OWN	APVD
		-		SEE SHEET 1			

FEED TYPE MECHANICAL

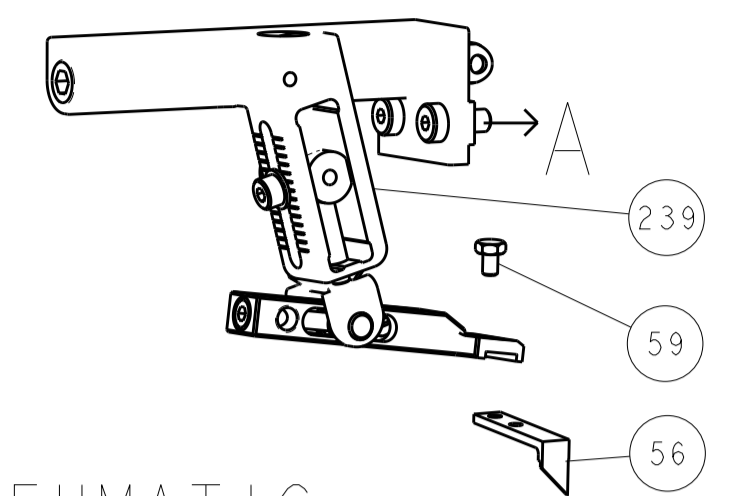

PNEUMATIC

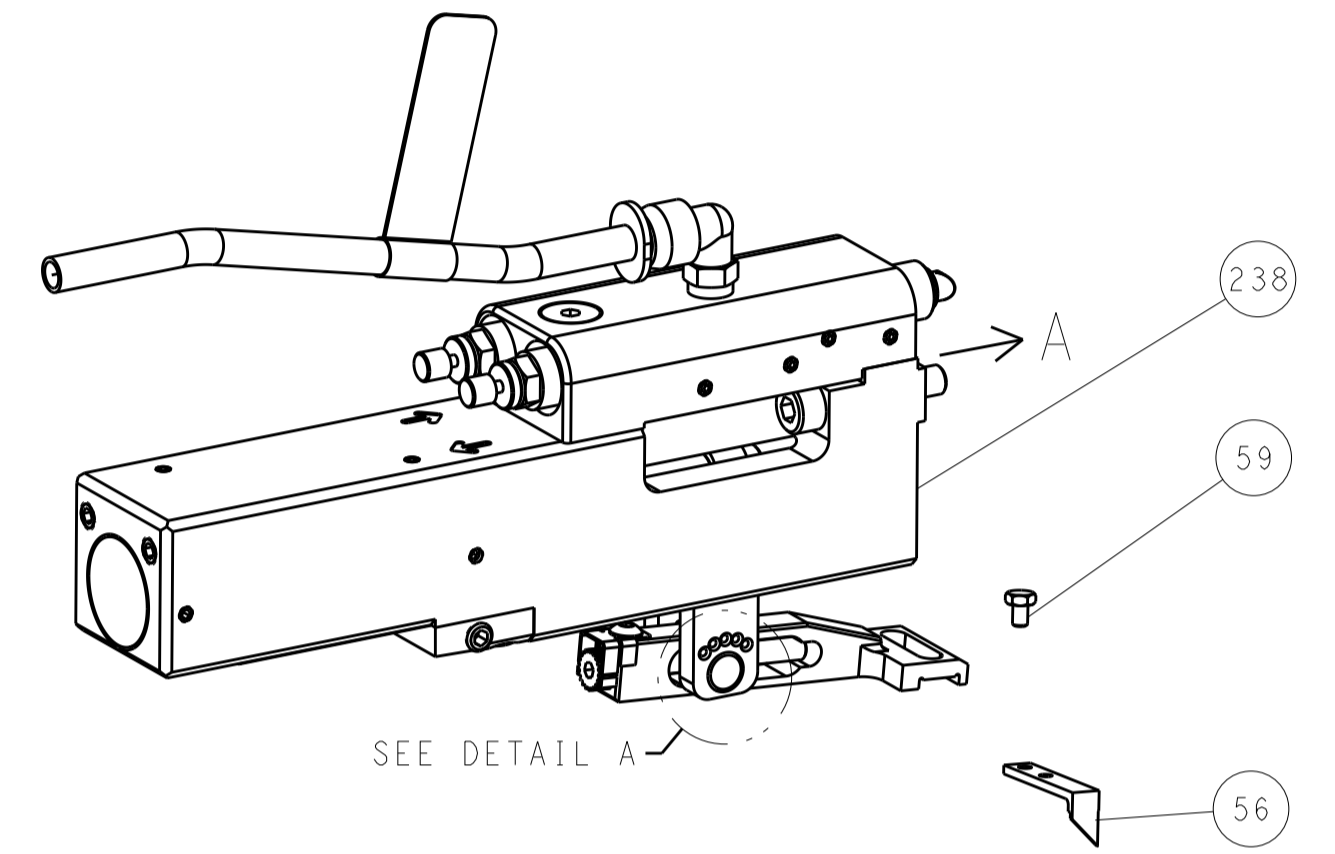

FEED SPRING SETTING POSITION (SHOWN FROM REAR SIDE)

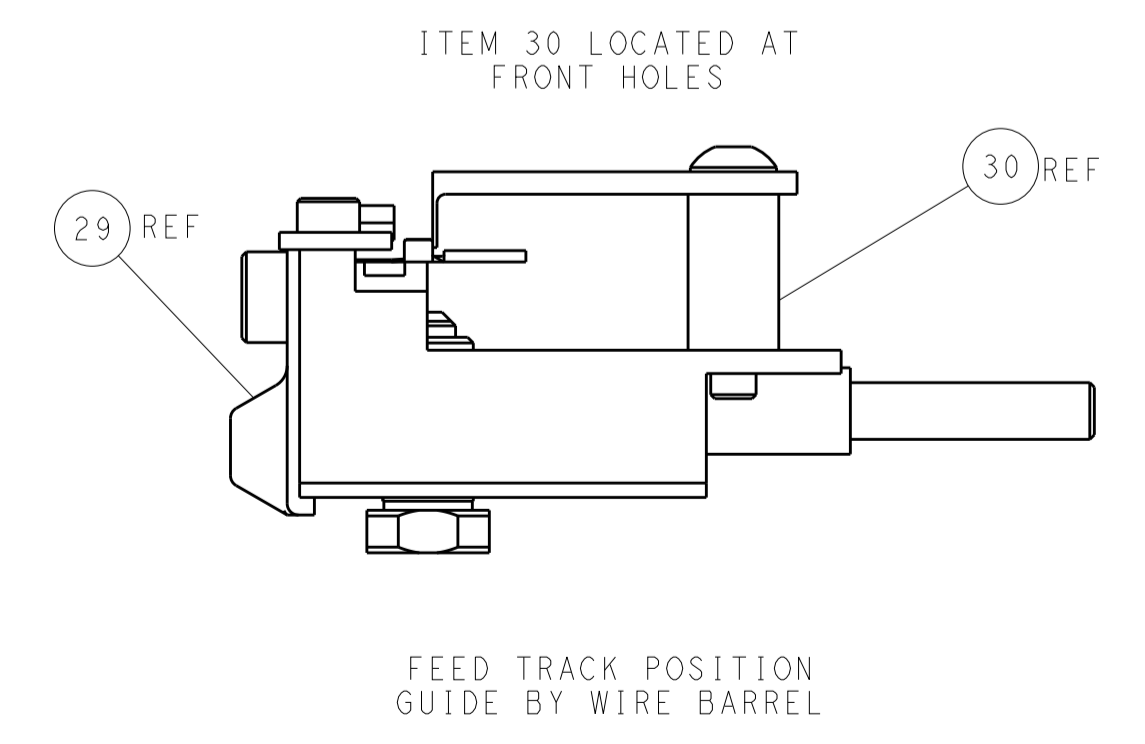
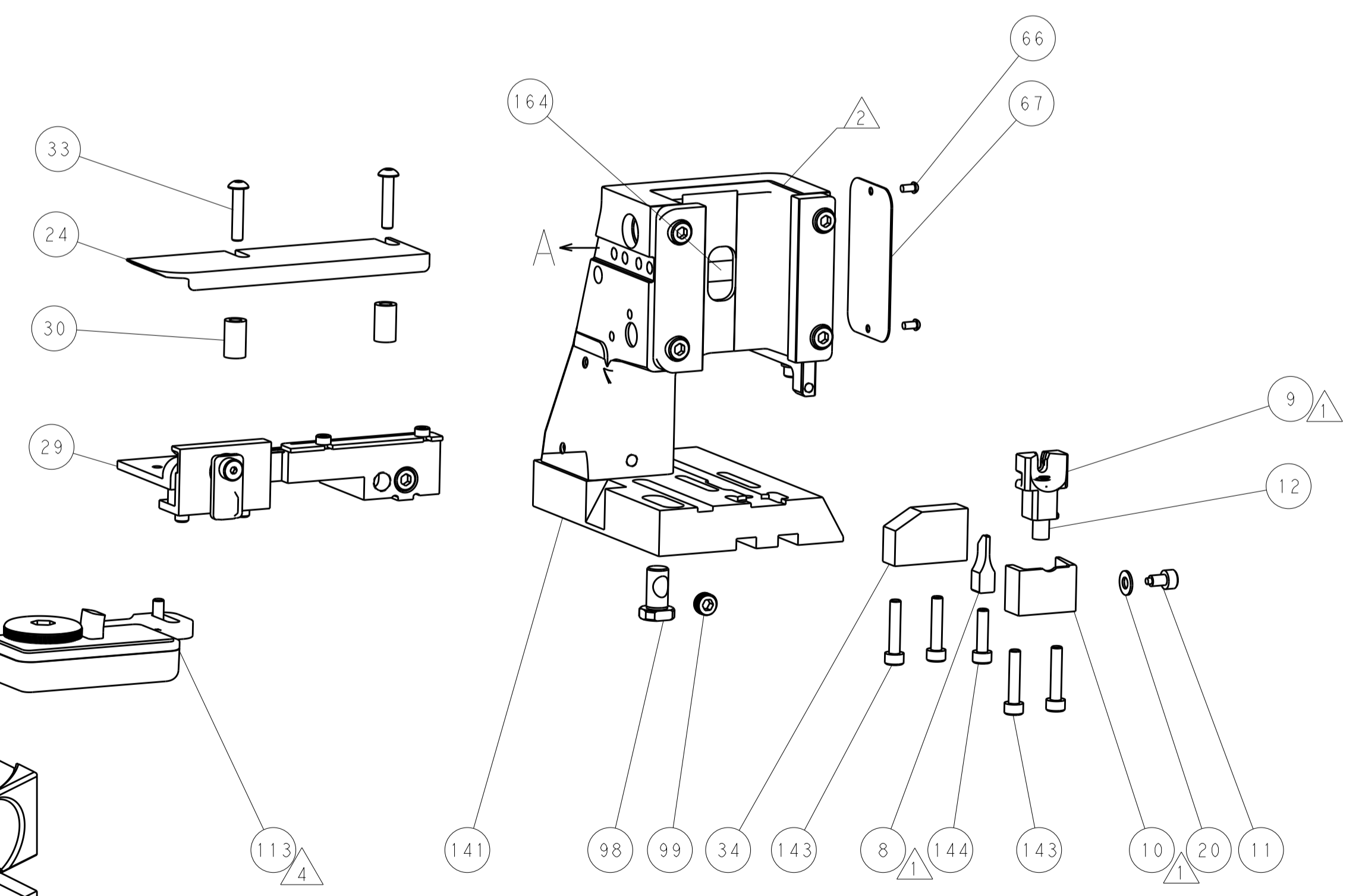
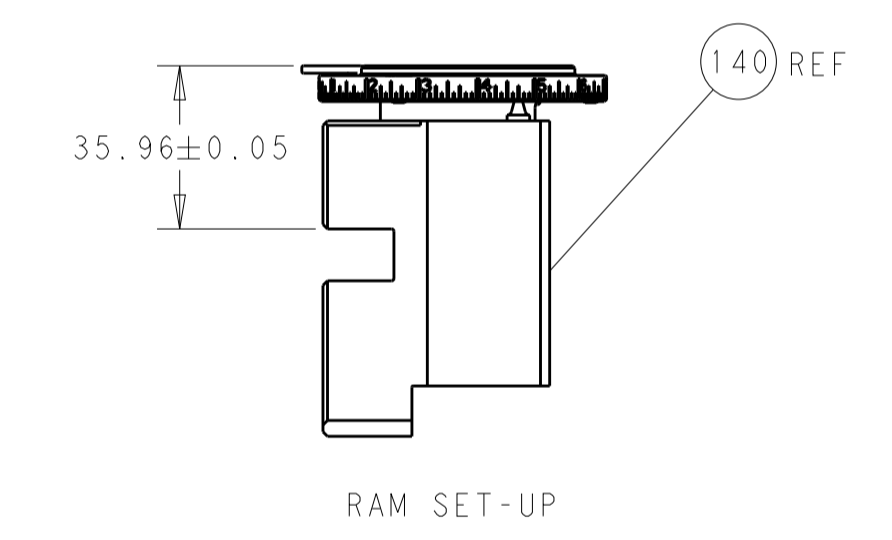
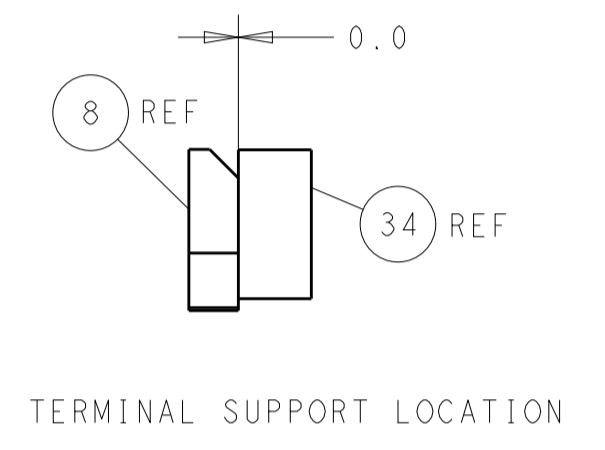
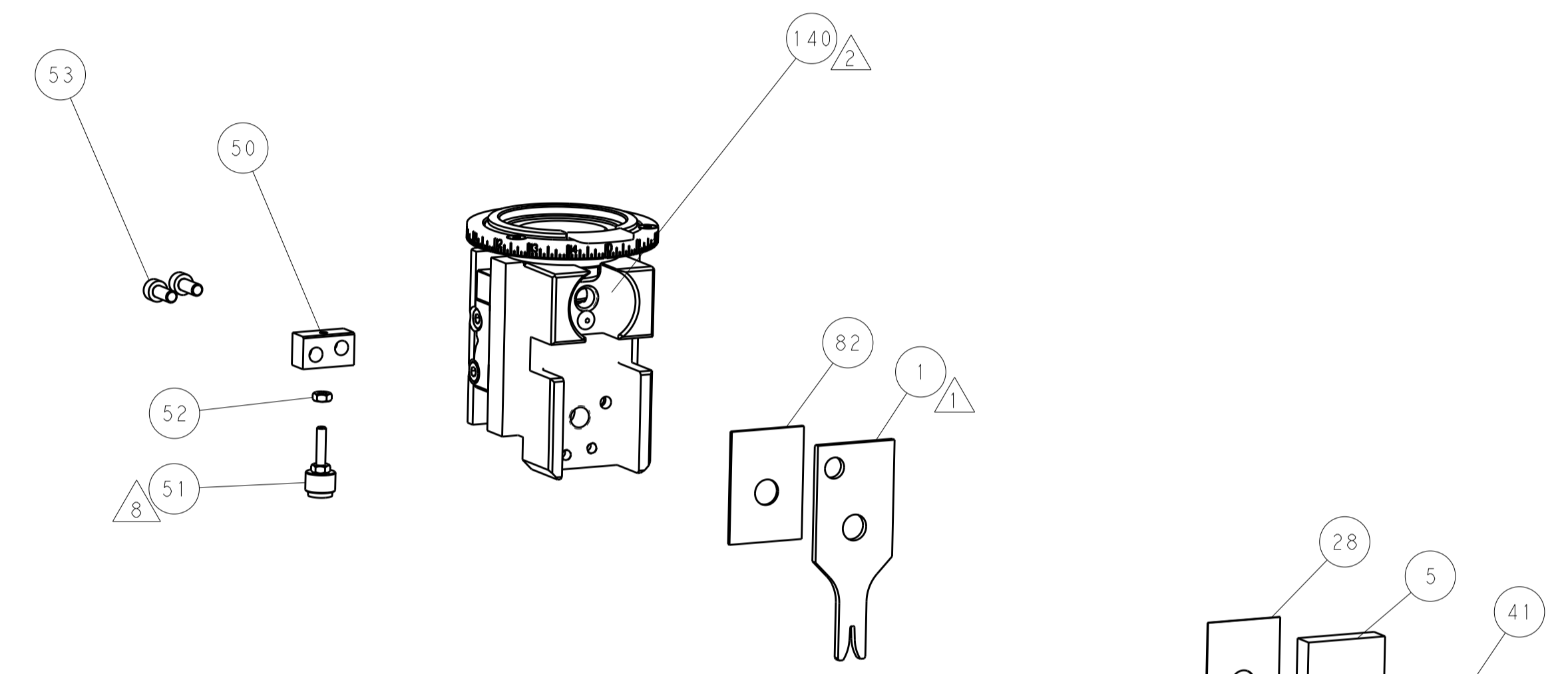
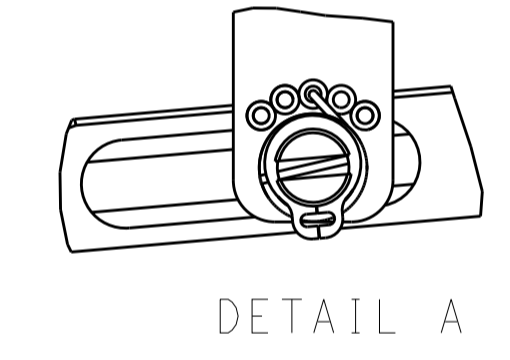

CAM POSITIONS

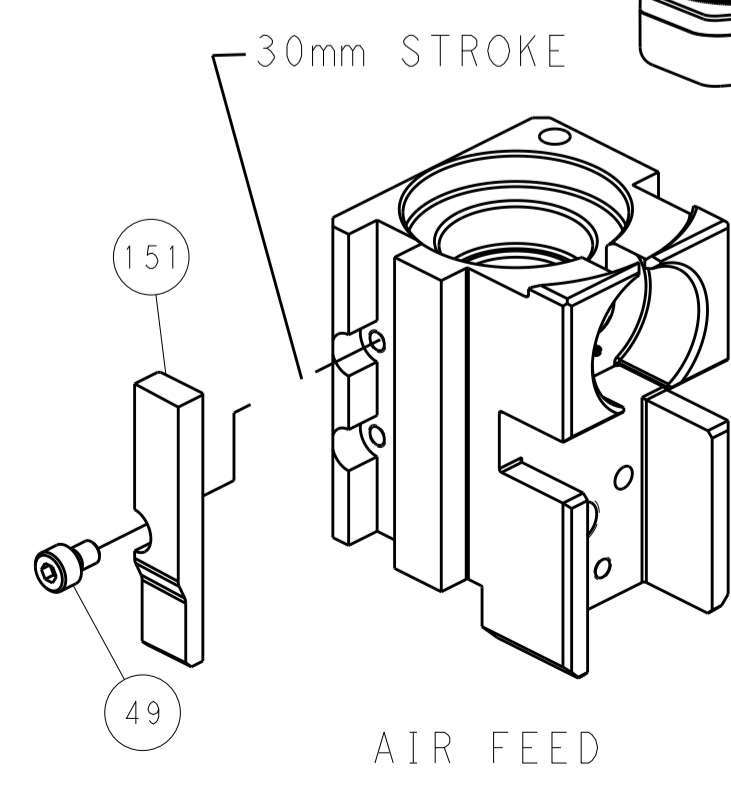
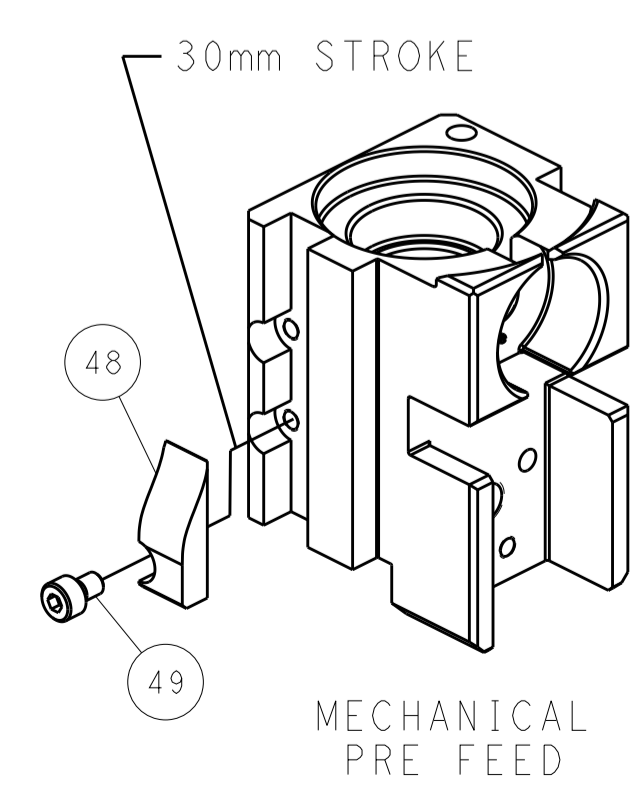
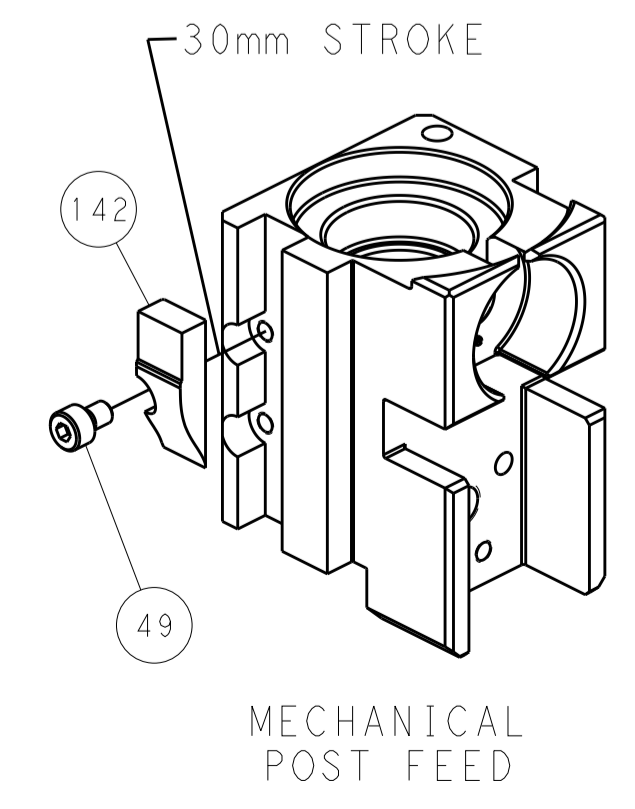

PACIFIC VERSION
 Shown on sheets 3 of 4 & 4 of 4
 (Atlantic version shown on sheets 1 of 4 & 2 of 4)

DIMENSIONS:		TOLERANCES UNLESS OTHERWISE SPECIFIED:		DWG: Y. YIN 30MAR2015		TE Connectivity	
mm	0 PLC ±	1 PLC ±	2 PLC ±	3 PLC ±	4 PLC ±	5 PLC ±	Harrisburg, PA 17105-3608
	ANGLES	FINISH		CHK: G. BAILEY 30MAR2015	NAME: Ocean Side Feed Applicator	RESTRICTED TO	
MATERIAL:		WEIGHT:		APVD: H. GUO 30MAR2015	SIZE: A1	CAGE CODE: 00779	DRAWING NO: C=2266736
Customer Accessible Production Drawing				SCALE: 1:2	SHEET: 4	OF: 4	REV: G