

ATLANTIC VERSION TERMINATOR  
 INTERFACE ADAPTER

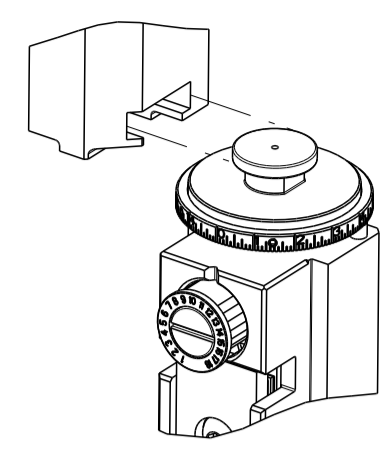

PART NUMBER	REVISION	DESCRIPTION	FEED TYPE
2266021-1	C	FINE CRIMP HEIGHT ADJUST	MECHANICAL
2266021-2	C	FINE CRIMP HEIGHT ADJUST	PNEUMATIC
5-2266021-1	C	SEAL STRIPPER CRIMPER TERMINATING UNIT	MECHANICAL
5-2266021-2	C	SEAL STRIPPER CRIMPER TERMINATING UNIT	PNEUMATIC
7-2266021-1	C	MECHANICAL AND CRIMP TOOLING KIT	MECHANICAL
7-2266021-2	C	PNEUMATIC AND CRIMP TOOLING KIT	PNEUMATIC
7-2266021-7	A	CRIMP TOOLING KIT	-

APPLICATOR DATA		
CRIMP	SIZE	TYPE
WIRE	1.40 mm [.055]	F
STAB	1.78 mm [.070]	O
INSUL	1.78 mm [.070]	O

APPLICATOR INSTRUCTIONS  
 408-35042

TERMINAL DATA: TE TERMINAL		TE CRIMP SPECIFICATION	
TERMINAL NAME: CONTACT-LOCKING CLIP			
WIRE STRIP LENGTH		INSULATION DIAMETER RANGE	
3.58-4.34 mm [.141-.171 IN]		Ø0.96-1.57 mm [.038-.062 IN]	
TERMINAL APPLICATION SPECIFICATION	114-25006		
TERMINALS APPLIED			
TE TERMINAL	TE TERMINAL	TE TERMINAL	TE TERMINAL
87124-1	87124-2	87124-3	5-87124-2
2267356-1			

TERMINAL DATA: TE TERMINAL		TE CRIMP SPECIFICATION	
TERMINAL NAME: CONTACT-LOCKING CLIP			
WIRE STRIP LENGTH		INSULATION DIAMETER RANGE	
3.58-4.34 mm [.141-.171 IN]		Ø1.27-2.54 mm [.050-.100 IN]	
TERMINAL APPLICATION SPECIFICATION	114-25006		
TERMINALS APPLIED			
TE TERMINAL	TE TERMINAL	TE TERMINAL	TE TERMINAL
867052-1	867052-2	5-867052-1	

WIRE SIZE	CRIMP HEIGHT mm [INCH]	CRIMP HEIGHT REFERENCE SETTING	STABILIZER CRIMP HEIGHT mm [INCH]	TE HOUSING
22 AWG	0.86+/-0.05 [.034+/-0.002]	7.9	2.08 +0/-0.10 [.0819 +.0000/-0.0039]	-
24 AWG	0.76+/-0.05 [.030+/-0.002]	8.9	2.08 +0/-0.10 [.0819 +.0000/-0.0039]	-
26 AWG	0.76+/-0.05 [.030+/-0.002]	9.0	2.08 +0/-0.10 [.0819 +.0000/-0.0039]	-

WIRE SIZE	CRIMP HEIGHT mm [INCH]	CRIMP HEIGHT REFERENCE SETTING	STABILIZER CRIMP HEIGHT mm [INCH]	TE HOUSING
20 AWG	1.02+/-0.05 [.040+/-0.002]	6.1	2.08 +0/-0.10 [.0819 +.0000/-0.0039]	-

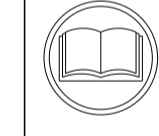

- 1 RECOMMENDED SPARE PARTS
- 2 REFER TO SUPPLIED INSTRUCTION SHEET FOR CLEANING, LUBRICATION AND STORAGE OF APPLICATOR.
- 3 APPLY PART NUMBER 2-23419-6 LOCTITE TO THREADS OF ITEM 242. APPLY PART NUMBER 1-23419-5 LOCTITE TO THREADS OF ITEM 180.
- 4 CRIMP HEIGHT REFERENCE SETTING WAS THE SETTING USED WHEN THE APPLICATOR WAS QUALIFIED AT THE FACTORY. ADJUSTMENT MAY BE NECESSARY WHEN RUNNING APPLICATOR IN THE FIELD.
- 5. UNLESS SPECIFIED OTHERWISE TORQUE VALUES SHALL BE USED PER DOCUMENT, 101-35000.
- 6 APPLICATOR WAS QUALIFIED TO STABILIZER CRIMP HEIGHT LISTED FOR ALL TERMINALS AND HOUSING COMBINATION ONLY. APPLICABLE HOUSINGS: 926657, 926209, 926659, AND 926663.

**\*WARNING**  
 ON INSTALLATION, SET WIRE DISC TO CRIMP HEIGHT REFERENCE SETTING FOR LARGEST WIRE SIZE. CRIMP HEIGHT REFERENCE SETTINGS GREATER THAN THE VALUE SHOWN MAY CAUSE DAMAGE TO THE CRIMP TOOLING. REFER TO THE INSTRUCTION SHEET FOR PROPER SETUP AND ADJUSTMENTS.

LOC	DIST	REVISIONS					
A	66	P	LTN	DESCRIPTION	DATE	OWN	APVD
		B1		ECR-16-006576	05MAY2016	JH	LZ
		B2		ECR-17-012792	31AUG2017	TB	TE
		B3		ECR-18-000786	18JAN2018	JAH	TE
		C		ECR-20-003074	03MAR2020	TB	TE

-	-	-	1	1	-	-	1803515-3	RAM ASSEMBLY, SF ATLANTIC	293
-	-	-	1	1	-	-	2-1803583-1	APPLICATOR BASIC ASSEMBLY, SF	292
-	1	1	1	1	1	1	2119791-5	DEPRESSOR, WIRE	286
-	1	1	1	1	1	1	455888-1	SPACER, CRIMPER	263
-	1	1	1	1	1	1	2-238011-0	BLOCK, CRIMPER SPACER	262
1	2	2	1	1	1	1	4-1803019-1	CRIMPER, INSULATION O	261
-	1	-	1	-	1	-	2119641-1	FEED CAM, AIR FEED	248
-	1	1	1	1	1	1	2119082-5	CAM, SNAIL, INSULATION ADJUSTMENT	244
-	1	1	1	1	1	1	2079764-1	WASHER, WAVE SPRING, CREST-TO-CREST	243
3	-	1	1	1	1	1	2119083-1	RETAINER, INSULATION DIAL	242
-	1	1	1	1	1	1	7-18023-7	SCR, SKT HD CAP M3 X 4.0	241
-	-	1	-	1	-	1	2119580-1	MECHANICAL FEED ASSEMBLY	239
-	1	-	1	-	1	-	2844940-1	AIR FEED MODULE	238
-	-	-	1	1	-	-	4-1722335-3	STRIPPER, SIDE FEED	182
3	-	-	1	1	-	-	1-5018030-0	NUT, HEX, REG, RoHS, M3.5	181
-	-	-	1	1	-	-	1-1752354-9	STANDOFF,HOLD-DOWN	180
-	-	-	1	1	-	-	993111-1	PIN, SLOTTED SPRING 3.0 X 20.0	177
-	-	-	1	1	-	-	5-22280-0	SPRING, COMPRESSION	176
-	-	-	1	1	-	-	1752353-3	GUIDE PIN,HOLDDOWN	175
-	-	-	1	1	-	-	1901680-2	GUIDE PIN,HOLDDOWN	174
-	REF	REF	REF	REF	REF	REF	994970-2	COUNTER, MAGNETIC	164
-	1	1	1	1	1	1	2844908-1	SCREW, LOCKING	99
-	1	1	1	1	1	1	2844907-1	POST, LOCKING	98
-	1	1	1	1	1	1	455888-4	SPACER, CRIMPER	82
-	1	1	1	1	1	1	1803607-3	DOCUMENTATION PACKAGE	71
-	1	1	1	1	1	1	2119740-1	TAG, IDENTIFICATION	67
-	2	2	2	2	2	2	2168078-1	SCREW, DRIVE, RH, RoHS, 2 x .188	66
-	1	1	1	1	1	1	2168083-2	SCR, SKT HD CAP, RoHS, M4 X 8.0	60
-	1	1	1	1	1	1	5-18022-5	SCR, HEX HD CAP, M4 X 6.0	59
-	1	1	1	1	1	1	1338685-1	PAWL, FEED	56
-	4	4	4	4	4	4	2168083-3	SCR, SKT HD CAP, RoHS, M4 X 12.0	54
-	2	2	-	-	2	2	1-2168083-0	SCR, SKT HD CAP, RoHS, M4 X 10	53
-	1	1	-	-	1	1	5018030-1	NUT, HEX, REG, RoHS, M3	52
-	1	1	-	-	1	1	811242-5	BUMPER, HOLD DOWN	51
-	1	1	-	-	1	1	690753-2	SPACER, TONKER	50
-	1	2	1	2	1	2	18023-9	SCR, SKT HD CAP M4 X 6.0	49
-	-	1	-	1	-	1	2119652-1	FEED CAM, PRE FEED	48
-	-	1	-	1	-	1	2119653-1	FEED CAM, POST FEED	47
-	1	1	-	-	1	1	1803583-9	APPLICATOR BASIC ASSEMBLY, SF	46
-	1	1	-	-	1	1	1803515-1	RAM ASSEMBLY, SF ATLANTIC	44
-	1	1	1	1	1	1	1803602-1	SCR, BHSC, RoHS (M8 X 25)	41
-	1	1	1	1	1	1	6-1752356-7	SUPPORT, TERMINAL	34
-	2	2	2	2	2	2	2079383-5	SCR, BHSC, RoHS (M4 X 20)	33
-	2	2	2	2	2	2	2-2844962-4	SPACER, CYLINDRICAL, STRIP GUIDE	30
-	1	1	1	1	1	1	2844992-1	ASSEMBLY, STRIP GUIDE	29
-	1	1	1	1	1	1	1320928-2	STRIP GUIDE	24
-	1	1	-	-	1	1	2168083-2	SCR, SKT HD CAP, RoHS, M4 X 8.0	21
-	2	2	1	1	2	2	1-18028-2	WASHER, FLAT, REG M4	20
-	1	1	-	-	1	1	2119533-1	STRIPPER, SIDE FEED	19
1	-	1	1	1	1	1	2119806-1	INSERT, SHEAR	13
-	1	1	1	1	1	1	3-22280-3	SPRING, COMPRESSION	12
-	1	1	1	1	1	1	1-356885-4	STOP, SHEAR	11
1	1	1	1	1	1	1	2119805-1	SHEAR HOLDER, FRONT	10
1	1	1	1	1	1	1	1803095-6	FLOATING SHEAR, FRONT	9
1	2	2	1	1	1	1	1-1633917-8	ANVIL, COMBINATION	8
-	-	-	-	-	-	-	-	-	7
-	-	-	-	-	-	-	-	-	6
-	1	1	1	1	1	1	2119757-8	DEPRESSOR, SHEAR	5
-	1	1	1	1	1	1	1-238011-7	BLOCK, CRIMPER SPACER	4
1	2	2	1	1	1	1	9-2119784-3	CRIMPER, INSULATION O PREMIUM	3
-	1	1	1	1	1	1	455888-2	SPACER, CRIMPER	2
1	2	2	1	1	1	1	2-456402-5	CRIMPER, WIRE PREMIUM	1

ITEM NO	PART NO	DESCRIPTION	ITEM NO
-77	-72	-71	-52
-51	-2	-1	

THIS DRAWING IS UNPUBLISHED. RELEASED FOR PUBLICATION. ALL RIGHTS RESERVED.	OWN: C. CHEN 20AUG2013	TE Connectivity Harrisburg, PA 17105-3608
CHK: U. GUO 20AUG2013	NAME: Ocean Side Feed Applicator	
APVD: J. CRUZ 20AUG2013	SIZE: A1 CAGE CODE: 00779 DRAWING NO: 2266021	
	SCALE: 1:2 SHEET 1 OF 4 REV C	

ATLANTIC VERSION  
 Shown on sheets 1 of 4 & 2 of 4  
 (Pacific version shown on sheets 3 of 4 & 4 of 4)

LOC	DIST	REVISIONS					
		P	LTN	DESCRIPTION	DATE	DWN	APVD
A	66	-	-	SEE SHEET 1	-	-	-

# FEED TYPE MECHANICAL

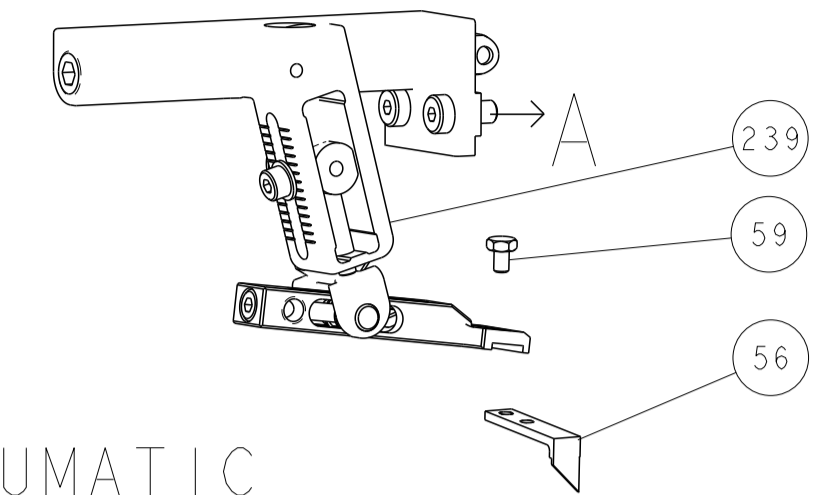

## PNEUMATIC

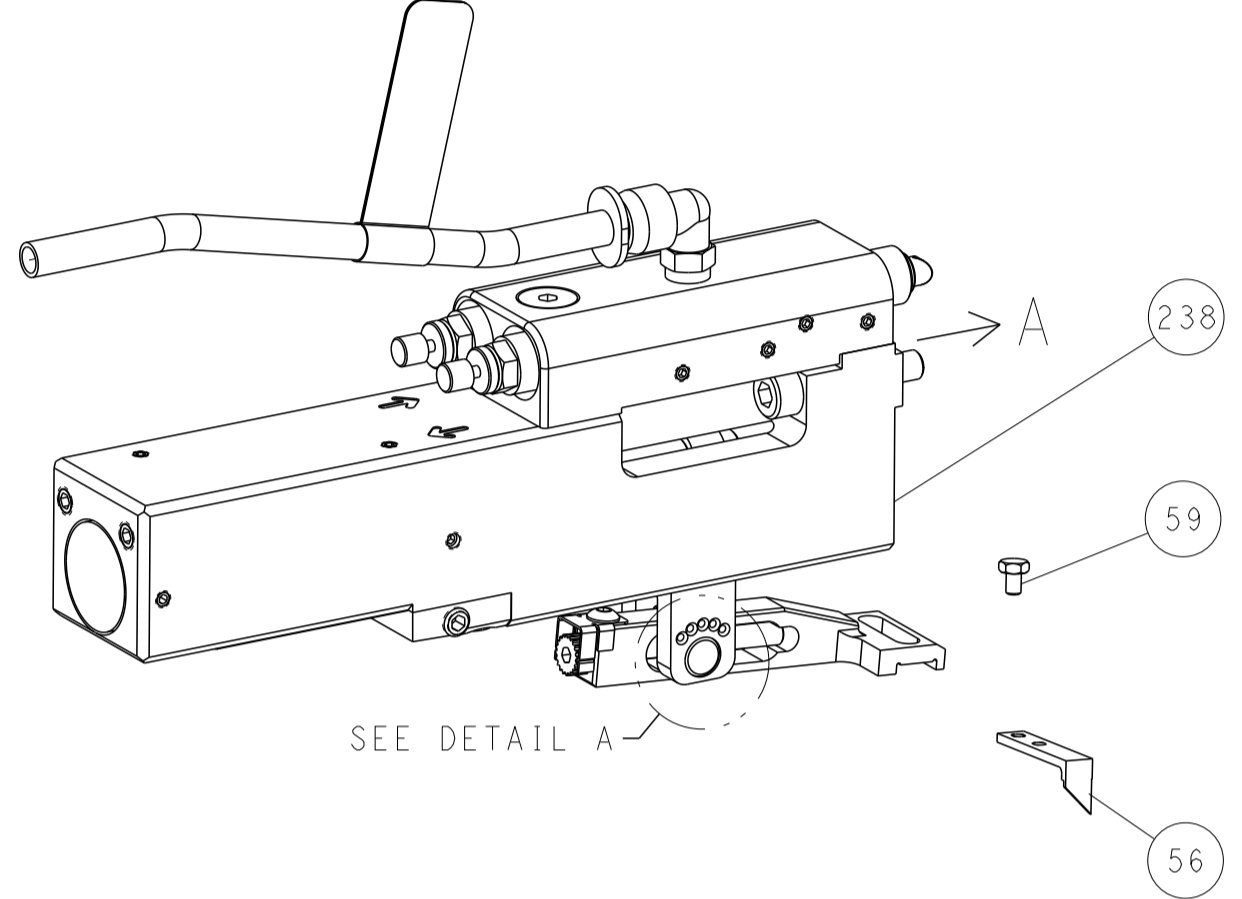

## FEED SPRING SETTING POSITION (SHOWN FROM REAR SIDE)

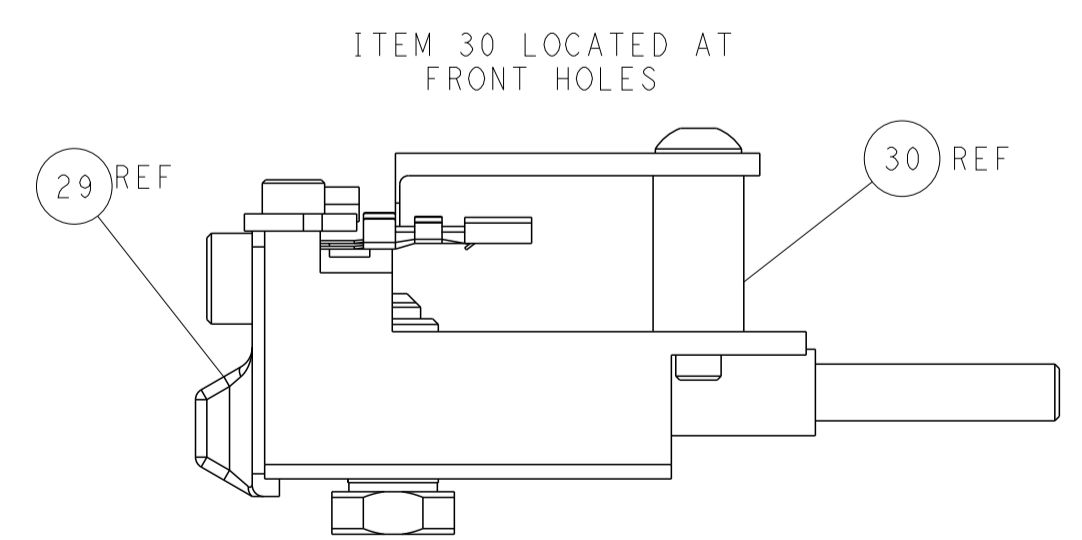
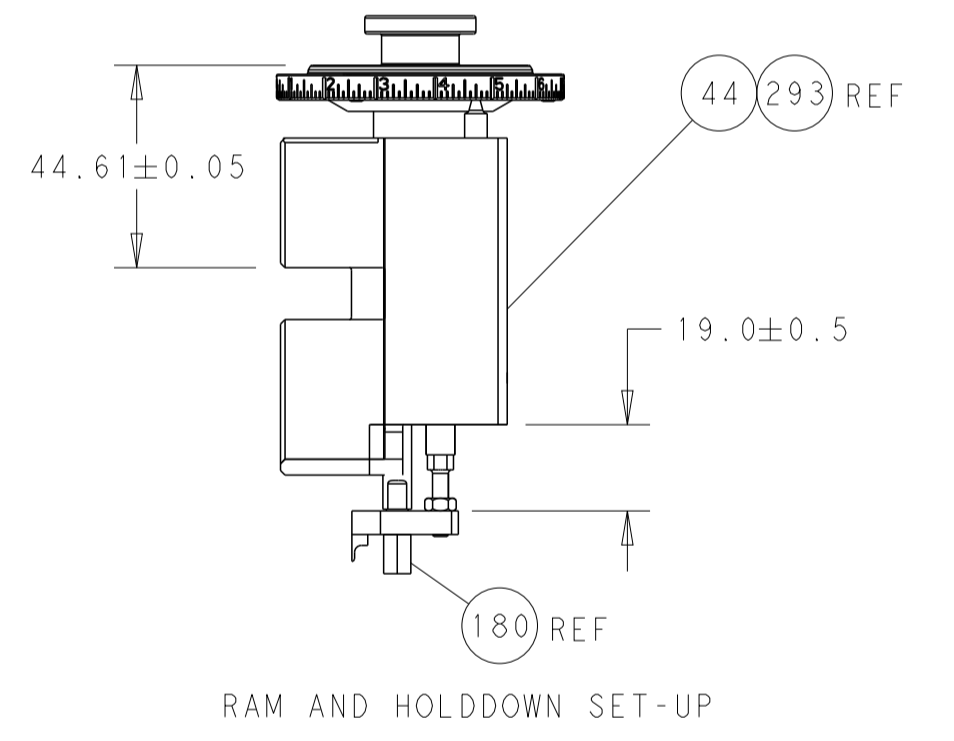
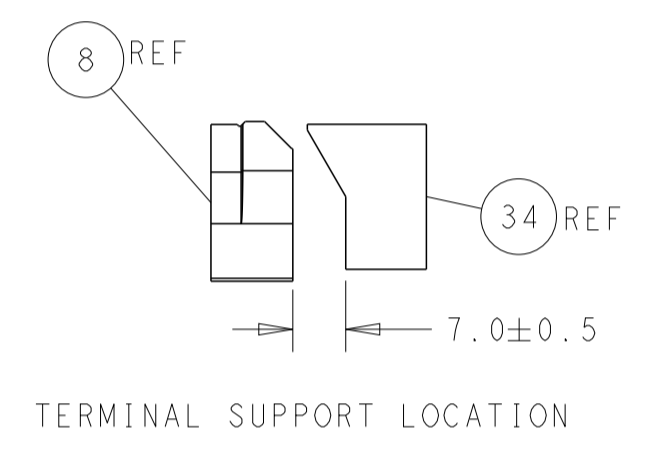
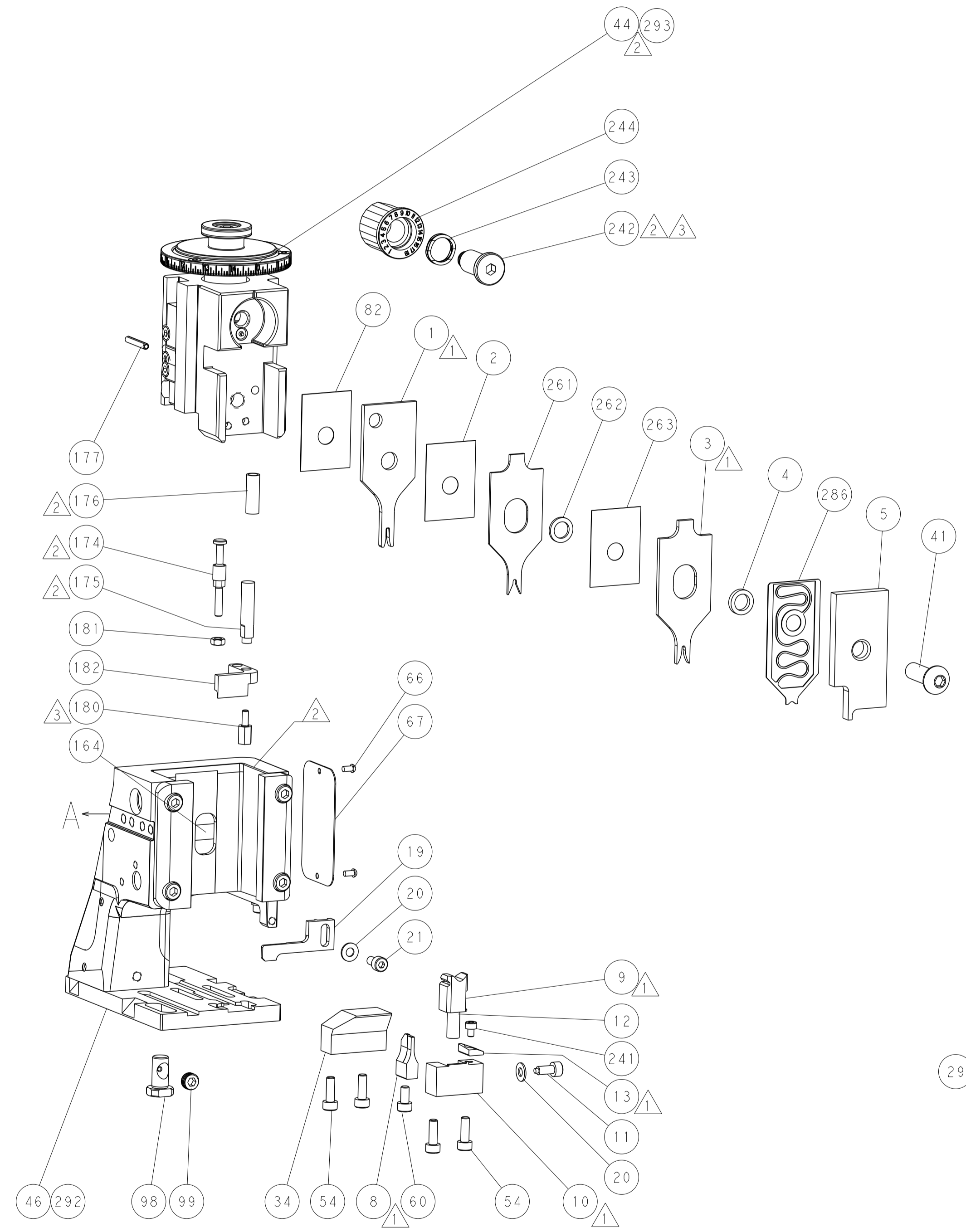
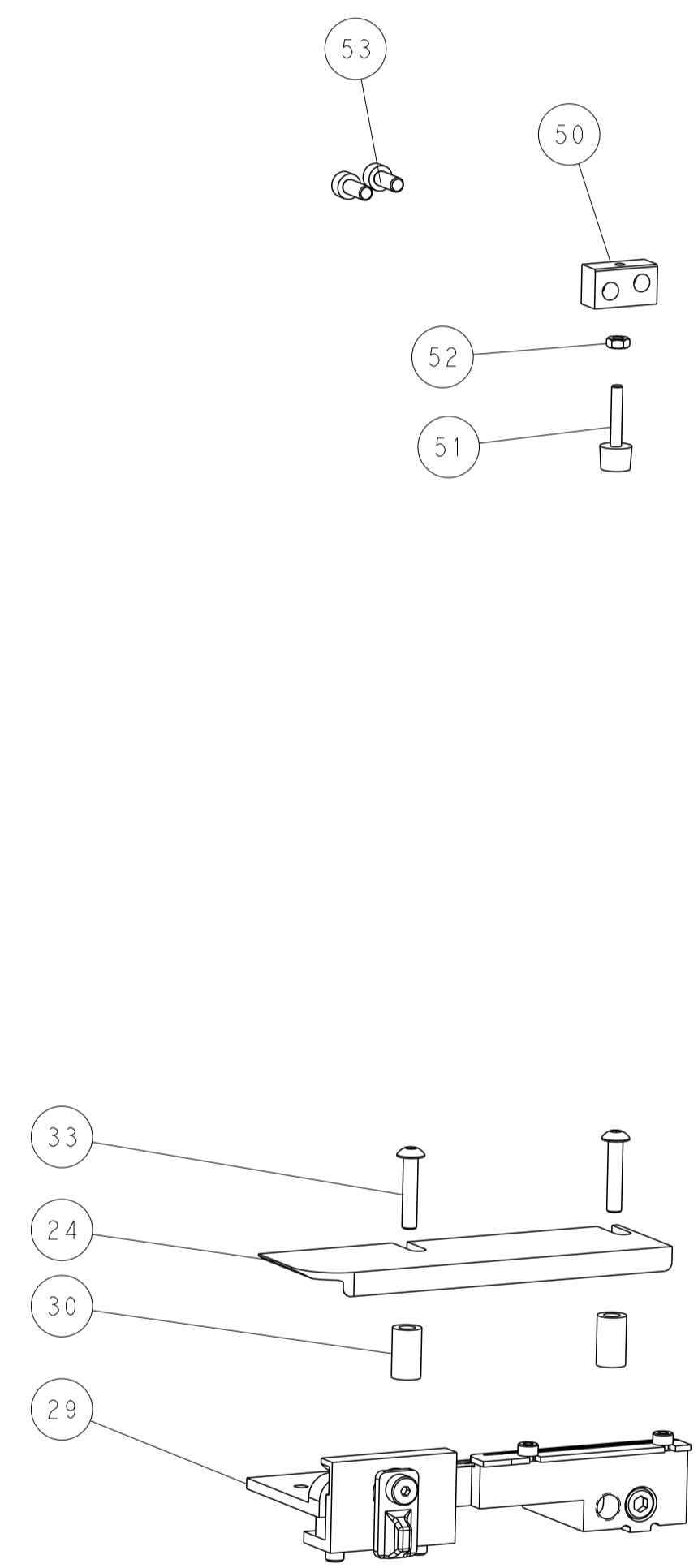
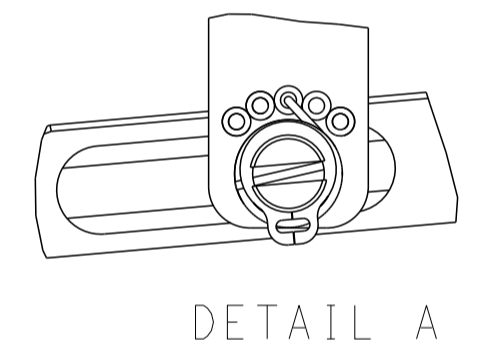

## CAM POSITIONS

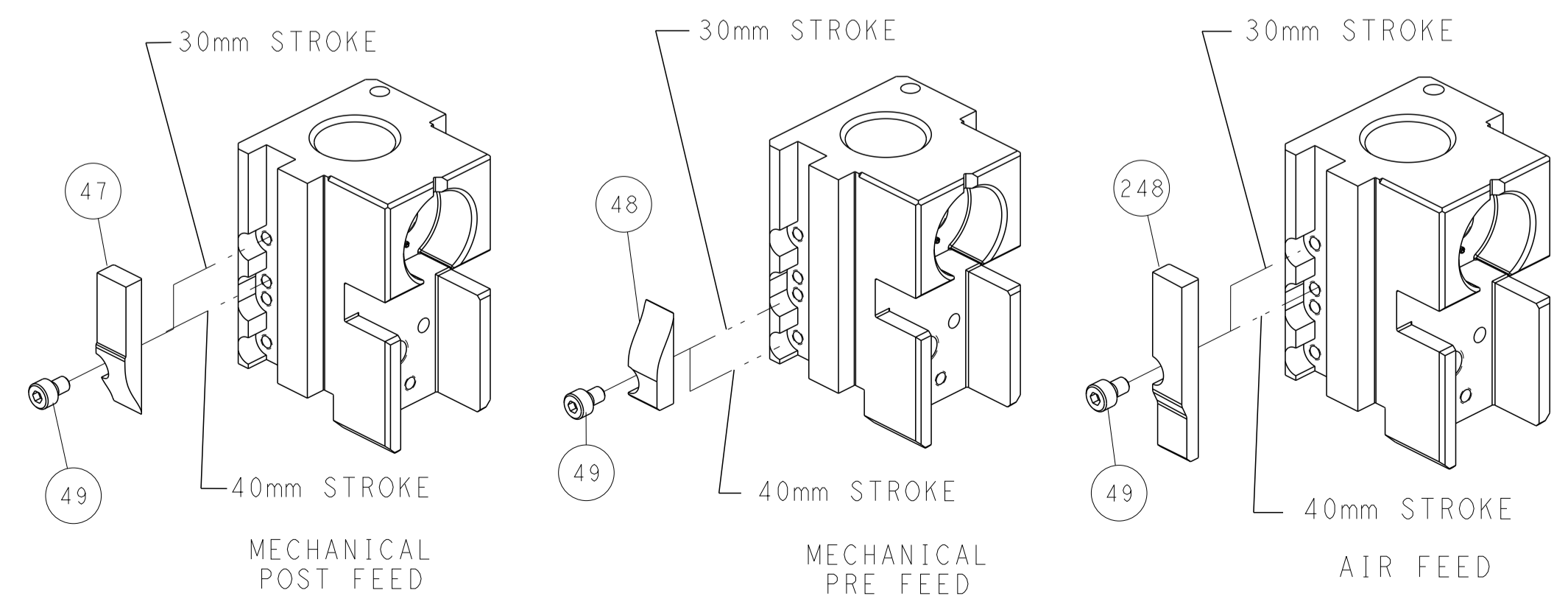

**ATLANTIC VERSION**  
 Shown on sheets 1 of 4 & 2 of 4  
 (Pacific version shown on sheets 3 of 4 & 4 of 4)

<small>THIS DRAWING IS UNPUBLISHED. RELEASED FOR PUBLICATION BY TYCO ELECTRONICS CORPORATION. ALL RIGHTS RESERVED.</small>		DWN: C. CHEN 20AUG2013 CHK: U. GUO 20AUG2013 APVD: J. CRUZ 20AUG2013	NAME: Ocean Side Feed Applicator SIZE: A1 CAGE CODE: 00779 DRAWING NO: 2266021	TE Connectivity Harrisburg, PA 17105-3608
DIMENSIONS: mm TOLERANCES UNLESS OTHERWISE SPECIFIED: 0 PLC ± 1 PLC ± 2 PLC ± 3 PLC ± 4 PLC ± ANGLES ± FINISH	TOLERANCES UNLESS OTHERWISE SPECIFIED: 0 PLC ± 1 PLC ± 2 PLC ± 3 PLC ± 4 PLC ± ANGLES ± FINISH	PRODUCT SPEC APPLICATION SPEC WEIGHT CUSTOMER DRAWING	SCALE: 1:2 SHEET: 2 of 4 REV: C	RESTRICTED TO:

PART NUMBER	REVISION	DESCRIPTION	FEED TYPE
2-2266021-1	C	FINE CRIMP HEIGHT ADJUST	MECHANICAL
2-2266021-2	C	FINE CRIMP HEIGHT ADJUST	PNEUMATIC
7-2266021-7	A	CRIMP TOOLING KIT	-

PACIFIC VERSION TERMINATOR  
INTERFACE ADAPTER

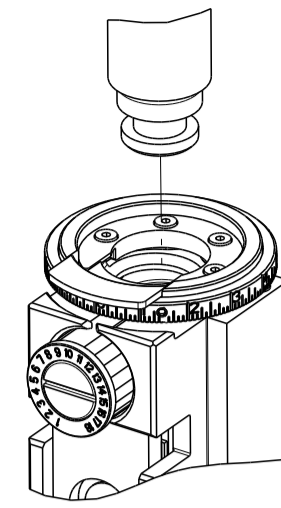

APPLICATOR DATA		
CRIMP	SIZE	TYPE
WIRE	1.40 mm [.055]	F
STAB	1.78 mm [.070]	O
INSUL	1.78 mm [.070]	O

APPLICATOR INSTRUCTIONS  
408-35042

TERMINAL DATA: TE TERMINAL		TE CRIMP SPECIFICATION	
TERMINAL NAME: CONTACT-LOCKING CLIP			
WIRE STRIP LENGTH		INSULATION DIAMETER RANGE	
3.58-4.34 mm [.141-.171 IN]		Ø0.96-1.57 mm [.038-.062 IN]	
TERMINAL APPLICATION SPECIFICATION	114-25006/6	-	-
TERMINALS APPLIED/6			
TE TERMINAL	TE TERMINAL	TE TERMINAL	TE TERMINAL
87124-1	87124-2	87124-3	5-87124-2
2267356-1			

TERMINAL DATA: TE TERMINAL		TE CRIMP SPECIFICATION	
TERMINAL NAME: CONTACT-LOCKING CLIP			
WIRE STRIP LENGTH		INSULATION DIAMETER RANGE	
3.58-4.34 mm [.141-.171 IN]		Ø1.27-2.54 mm [.050-.100 IN]	
TERMINAL APPLICATION SPECIFICATION	114-25006/6	-	-
TERMINALS APPLIED/6			
TE TERMINAL	TE TERMINAL	TE TERMINAL	TE TERMINAL
867052-1	867052-2	5-867052-1	

WIRE SIZE	CRIMP HEIGHT mm [INCH]	CRIMP HEIGHT REFERENCE SETTING	STABILIZER CRIMP HEIGHT mm [INCH]	TE HOUSING
22 AWG	0.86 +/- 0.05 [.034 +/- .002]	7.9	2.08 +0/-0.10 [.0819 +.0000/- .0039]	-
24 AWG	0.76 +/- 0.05 [.030 +/- .002]	8.9	2.08 +0/-0.10 [.0819 +.0000/- .0039]	-
26 AWG	0.76 +/- 0.05 [.030 +/- .002]	9.0	2.08 +0/-0.10 [.0819 +.0000/- .0039]	-

WIRE SIZE	CRIMP HEIGHT mm [INCH]	CRIMP HEIGHT REFERENCE SETTING	STABILIZER CRIMP HEIGHT mm [INCH]	TE HOUSING
20 AWG	1.02 +/- 0.05 [.040 +/- .002]	6.1	2.08 +0/-0.10 [.0819 +.0000/- .0039]	-

**\*WARNING**  
ON INSTALLATION, SET WIRE DISC TO CRIMP HEIGHT REFERENCE SETTING FOR LARGEST WIRE SIZE. CRIMP HEIGHT REFERENCE SETTINGS GREATER THAN THE VALUE SHOWN MAY CAUSE DAMAGE TO THE CRIMP TOOLING. REFER TO THE INSTRUCTION SHEET FOR PROPER SETUP AND ADJUSTMENTS.

- 1. RECOMMENDED SPARE PARTS
- 2. REFER TO SUPPLIED INSTRUCTION SHEET FOR CLEANING, LUBRICATION AND STORAGE OF APPLICATOR.
- 3. APPLY PART NUMBER 2-23419-6 LOCTITE TO THREADS OF ITEM 242.
- 4. CRIMP HEIGHT REFERENCE SETTING WAS THE SETTING USED WHEN THE APPLICATOR WAS QUALIFIED AT THE FACTORY. ADJUSTMENT MAY BE NECESSARY WHEN RUNNING APPLICATOR IN THE FIELD.
- 5. UNLESS SPECIFIED OTHERWISE TORQUE VALUES SHALL BE USED PER DOCUMENT, 101-35000.
- 6. APPLICATOR WAS QUALIFIED TO STABILIZER CRIMP HEIGHT LISTED FOR ALL TERMINALS AND HOUSING COMBINATION ONLY. APPLICABLE HOUSINGS: 926657, 926209, 926659, AND 926663.

PACIFIC VERSION  
Shown on sheets 3 of 4 & 4 of 4  
(Atlantic version shown on sheets 1 of 4 & 2 of 4)

LOC	DIST	REVISIONS					
A	66	P	LTN	DESCRIPTION	DATE	DWN	APVD
-	-	-	-	SEE SHEET 1	-	-	-

-	1	1	2119791-5	DEPRESSOR, WIRE	286
-	1	1	455888-1	SPACER, CRIMPER	263
-	1	1	2-238011-0	BLOCK, CRIMPER SPACER	262
1	1	1	4-1803019-1	CRIMPER, INSULATION O	261
-	1	1	2119082-5	CAM, SNAIL, INSULATION ADJUSTMENT	244
-	1	1	2079764-1	WASHER, WAVE SPRING, CREST-TO-CREST	243
3	1	1	2119083-1	RETAINER, INSULATION DIAL	242
-	1	1	7-18023-7	SCR, SKT HD CAP M3 X 4.0	241
-	-	1	2119580-1	MECHANICAL FEED ASSEMBLY	239
-	1	-	2844940-1	AIR FEED MODULE	238
-	REF	REF	994970-2	COUNTER, MAGNETIC	164
-	1	-	2119641-2	FEED CAM, AIR FEED	151
-	1	1	2168083-8	SCR, SKT HD CAP, RoHS, M4 X 16	144
-	4	4	2168083-9	SCR, SKT HD CAP, RoHS, M4 X 20	143
-	-	1	2119653-2	FEED CAM, POST FEED	142
-	1	1	1-1803583-0	APPLICATOR BASIC ASSEMBLY, SF	141
-	1	1	1803516-1	RAM ASSEMBLY, SF PACIFIC	140
-	1	1	2844908-1	SCREW, LOCKING	99
-	1	1	2844907-1	POST, LOCKING	98
-	1	1	455888-4	SPACER, CRIMPER	82
-	1	1	1803607-3	DOCUMENTATION PACKAGE	71
-	1	1	2119740-1	TAG, IDENTIFICATION	67
-	2	2	2168078-1	SCREW, DRIVE, RH, RoHS, 2 x .188	66
-	1	1	5-18022-5	SCR, HEX HD CAP, M4 X 6.0	59
-	1	1	1338685-1	PAWL, FEED	56
-	2	2	1-2168083-0	SCR, SKT HD CAP, RoHS, M4 X 10	53
-	1	1	5018030-1	NUT, HEX, REG, RoHS, M3	52
-	1	1	811242-5	BUMPER, HOLD DOWN	51
-	1	1	690753-2	SPACER, TONKER	50
-	1	2	18023-9	SCR, SKT HD CAP M4 X 6.0	49
-	-	1	2119652-1	FEED CAM, PRE FEED	48
-	1	1	1803602-1	SCR, BHSC, RoHS (M8 X 25)	41
-	1	1	6-1752356-7	SUPPORT, TERMINAL	34
-	2	2	2079383-5	SCR, BHSC, RoHS (M4 X 20)	33
-	2	2	2-2844962-4	SPACER, CYLINDRICAL, STRIP GUIDE	30
-	1	1	2844992-1	ASSEMBLY, STRIP GUIDE	29
-	1	1	1320928-2	STRIP GUIDE	24
-	1	1	2168083-2	SCR, SKT HD CAP, RoHS, M4 X 8.0	21
-	2	2	1-18028-2	WASHER, FLAT, REG M4	20
-	1	1	2119533-1	STRIPPER, SIDE FEED	19
1	1	1	2119806-1	INSERT, SHEAR	13
-	1	1	3-22280-3	SPRING, COMPRESSION	12
-	1	1	1-356885-4	STOP, SHEAR	11
1	1	1	2119805-1	SHEAR HOLDER, FRONT	10
1	1	1	1803095-6	FLOATING SHEAR, FRONT	9
1	1	1	1-1633917-8	ANVIL, COMBINATION	8
-	-	-	-	-	7
-	-	-	-	-	6
-	1	1	2119757-8	DEPRESSOR, SHEAR	5
-	1	1	1-238011-7	BLOCK, CRIMPER SPACER	4
1	1	1	9-2119784-3	CRIMPER, INSULATION O PREMIUM	3
-	1	1	455888-2	SPACER, CRIMPER	2
1	1	1	2-456402-5	CRIMPER, WIRE PREMIUM	1

DIMENSIONS:		TOLERANCES UNLESS OTHERWISE SPECIFIED:		MATERIAL:		FINISH:		WEIGHT:		SCALE:	
mm	0 PLC ±	1 PLC ±	2 PLC ±	3 PLC ±	4 PLC ±	ANGLES ±	FINISH	WEIGHT	SCALE	SHEET	REV
										3	C

LOC	DIST	REVISIONS					
A	66	P	LTN	DESCRIPTION	DATE	OWN	APVD
		-		SEE SHEET 1	-	-	-

# FEED TYPE MECHANICAL

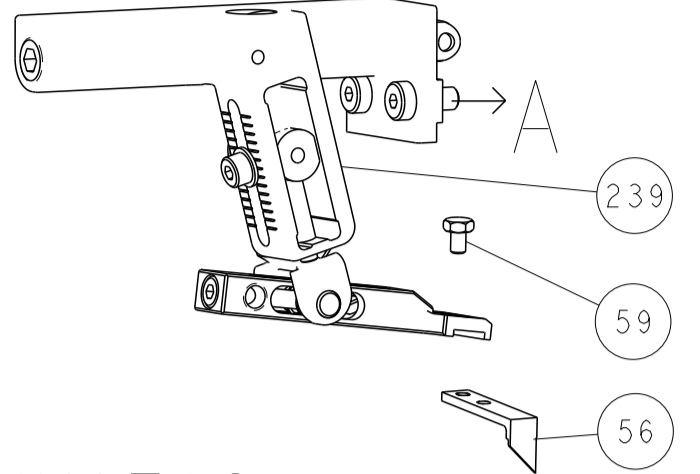

## PNEUMATIC

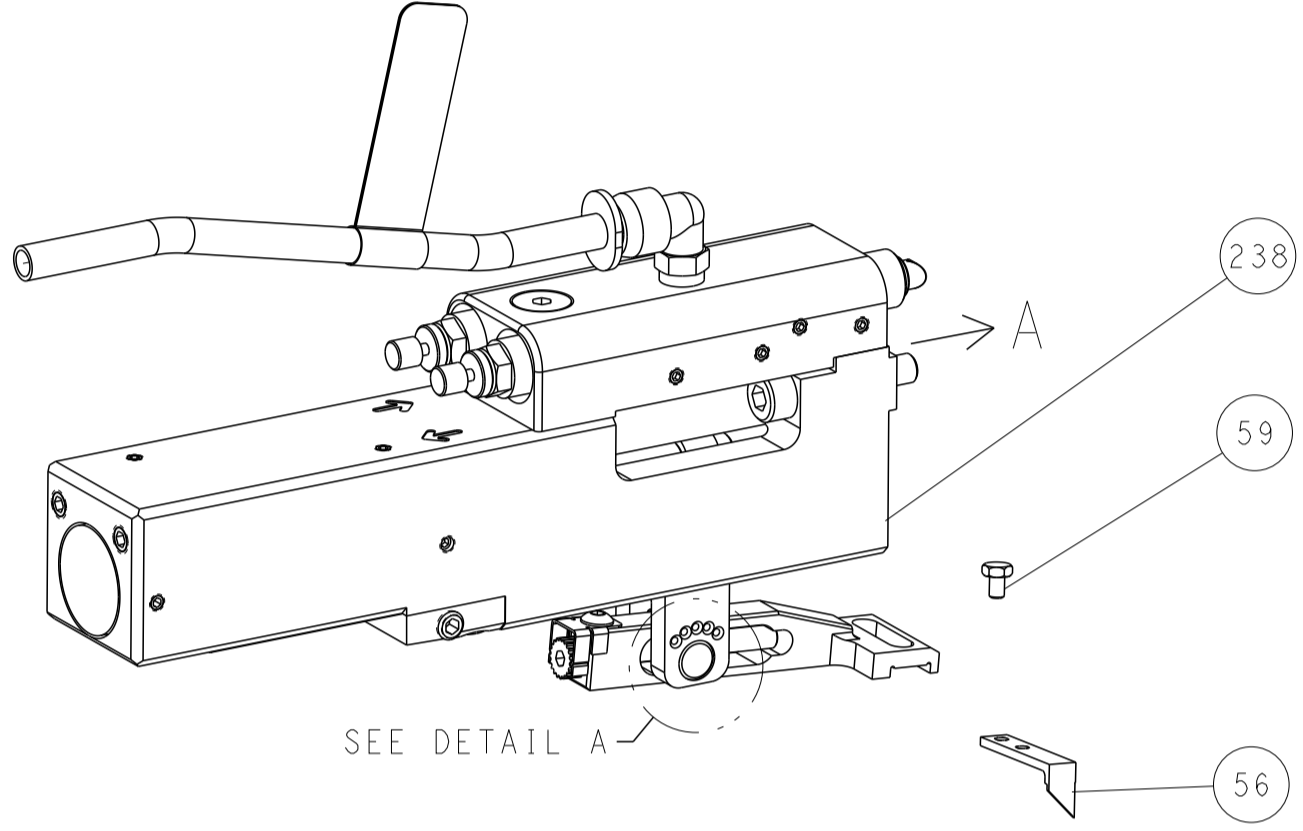

## FEED SPRING SETTING POSITION (SHOWN FROM REAR SIDE)

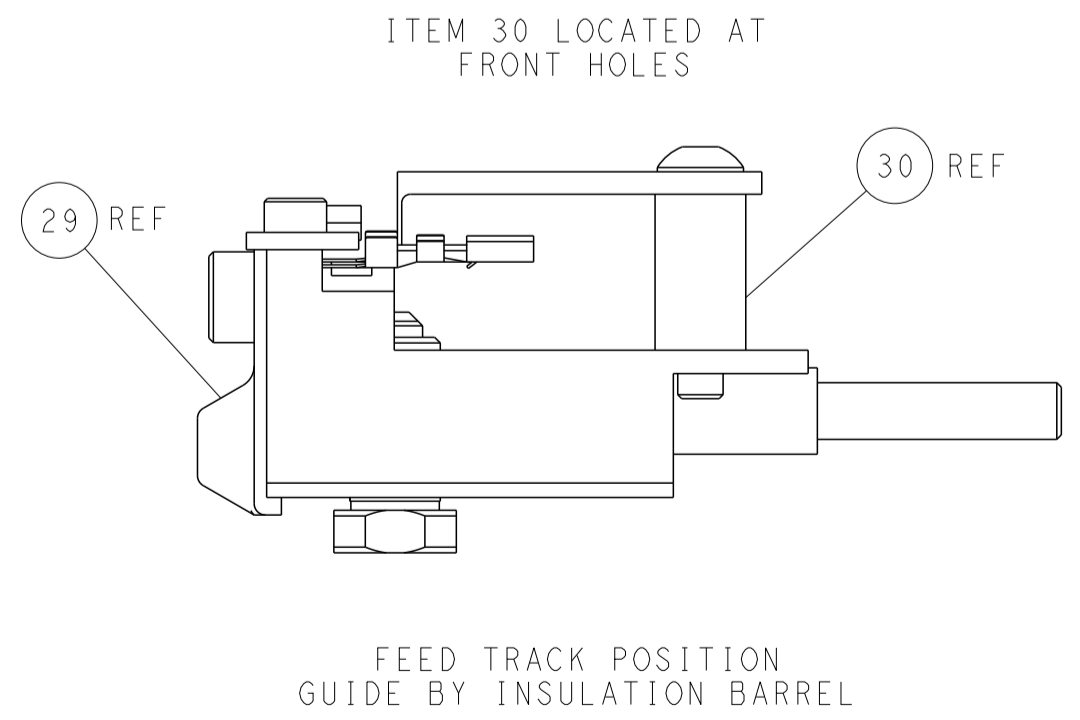
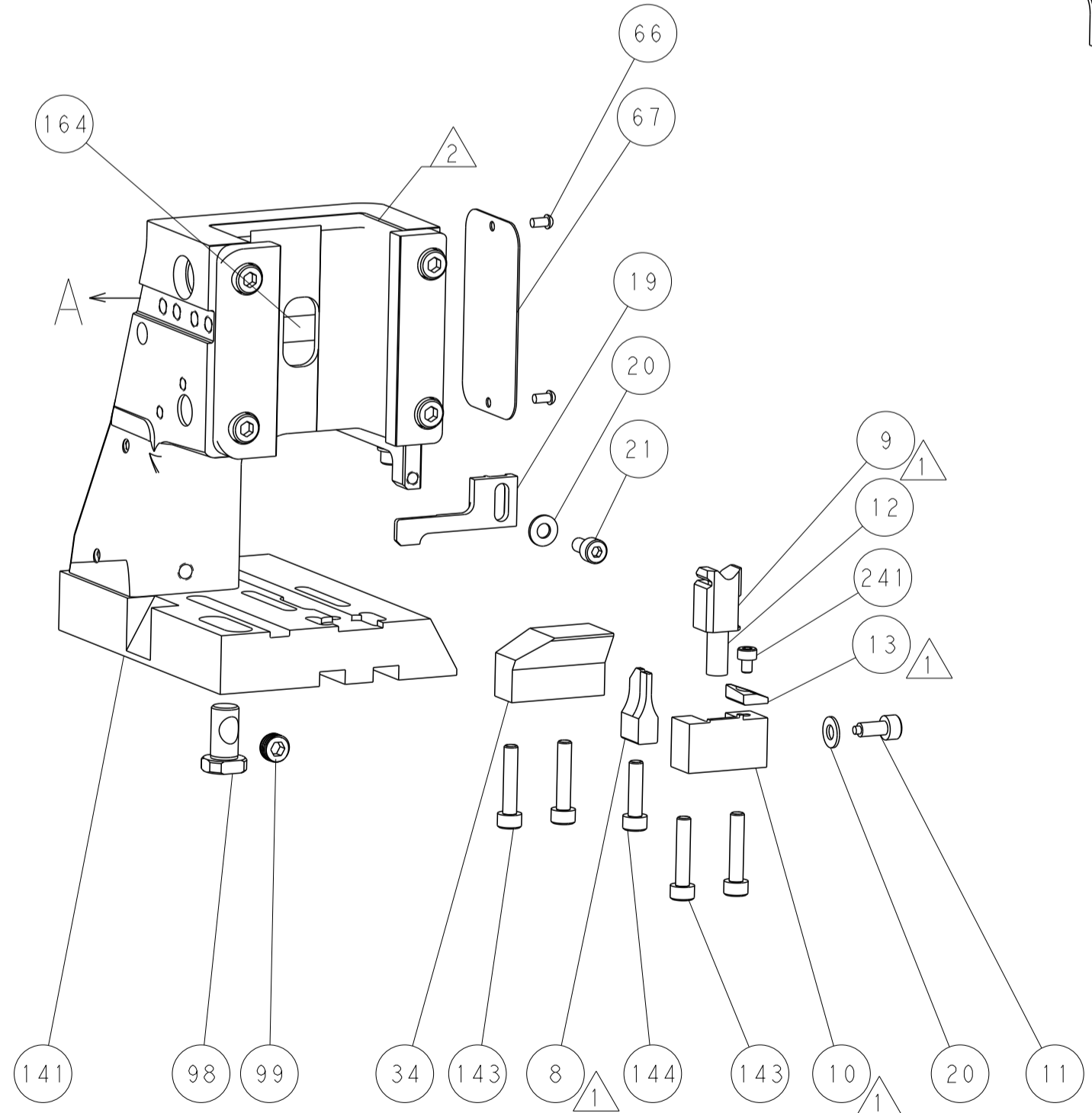
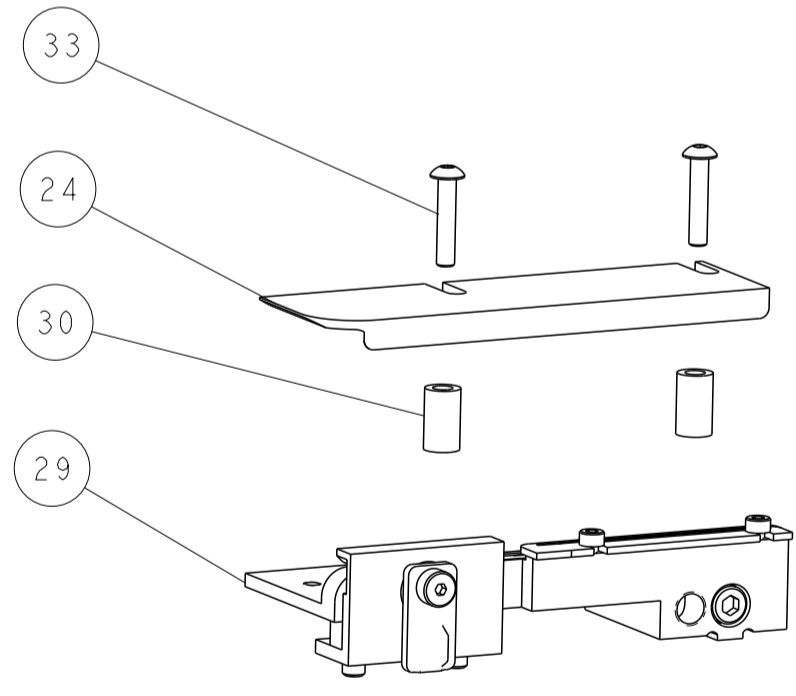
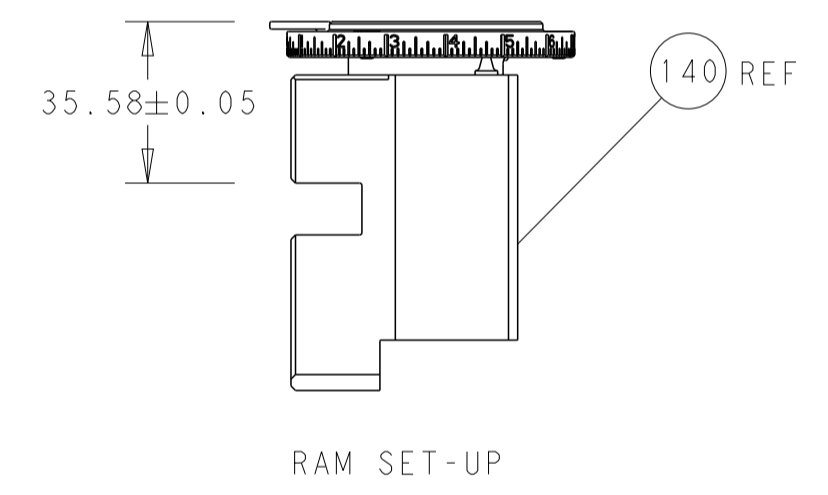
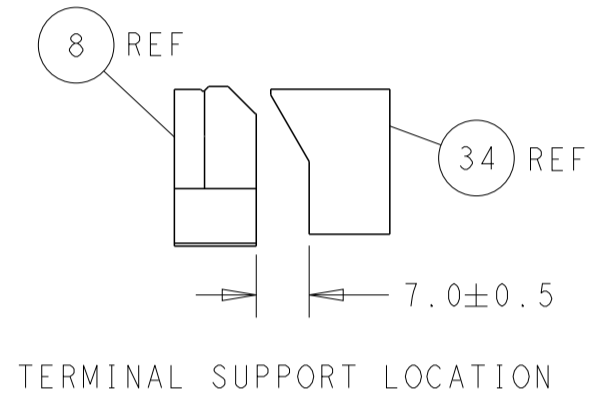
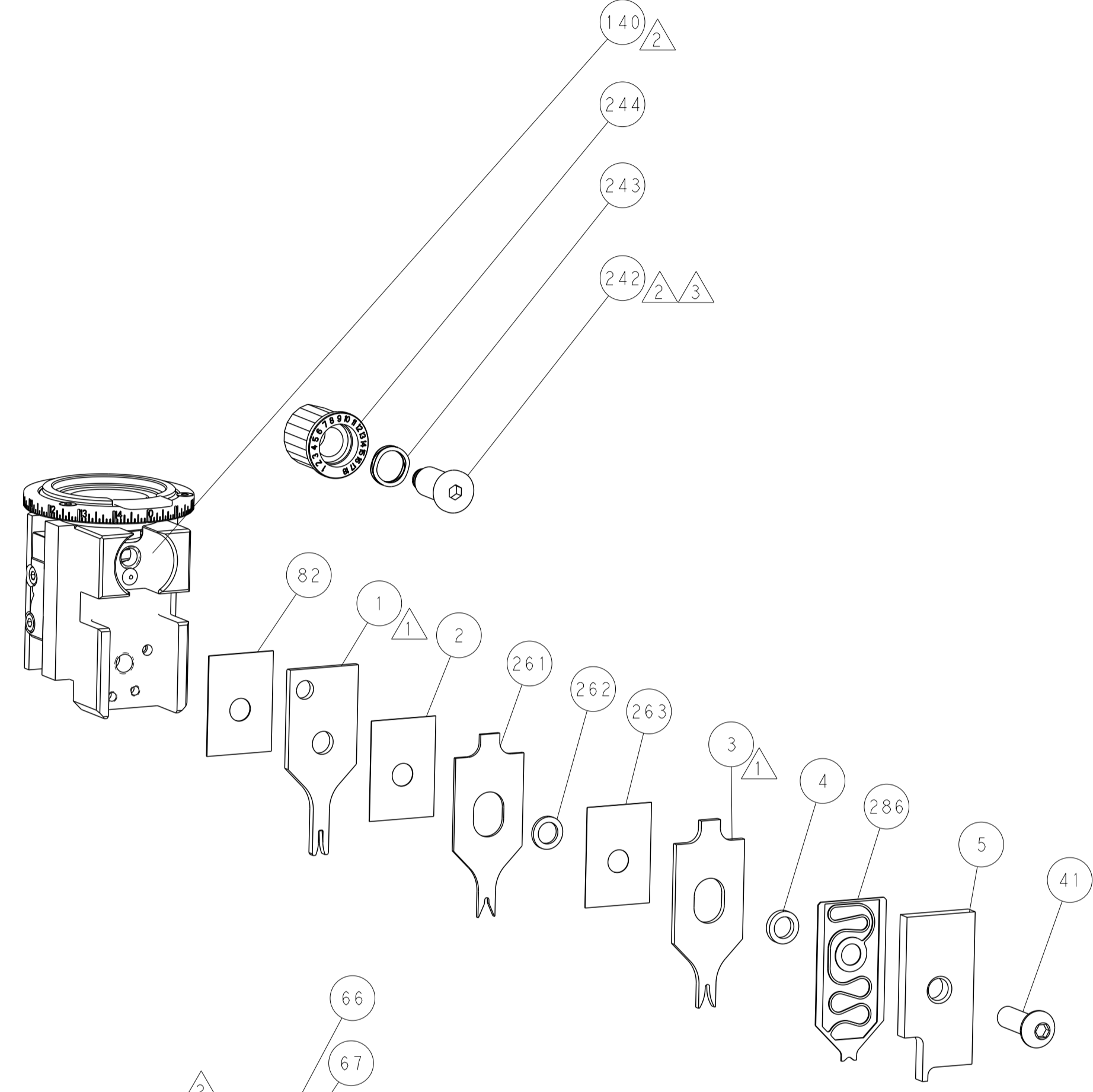
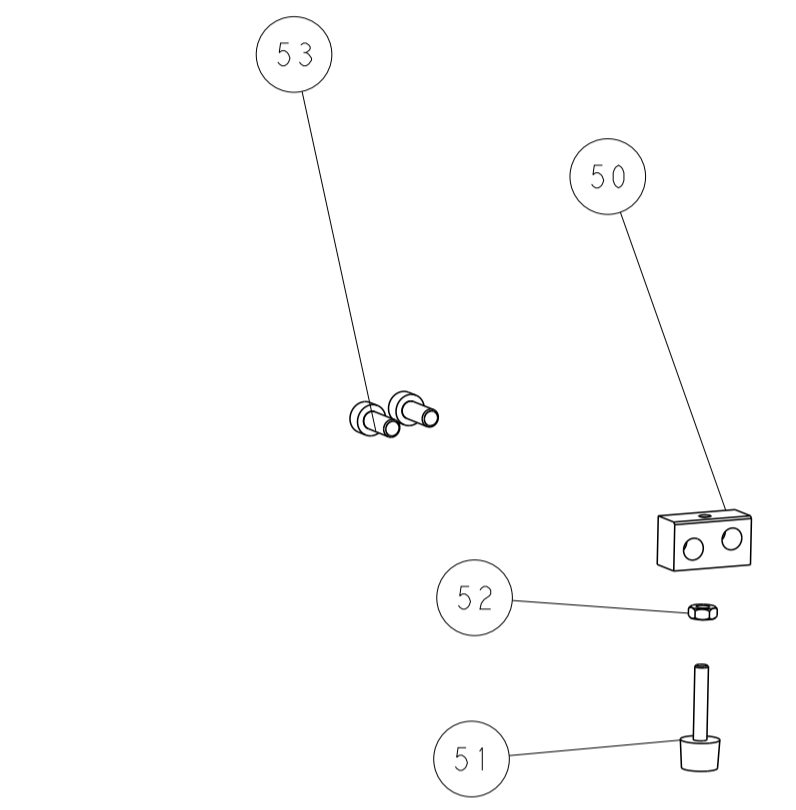
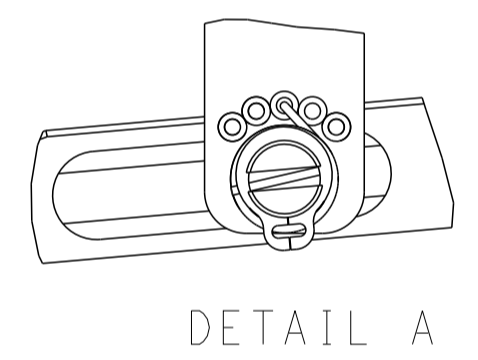

## CAM POSITIONS

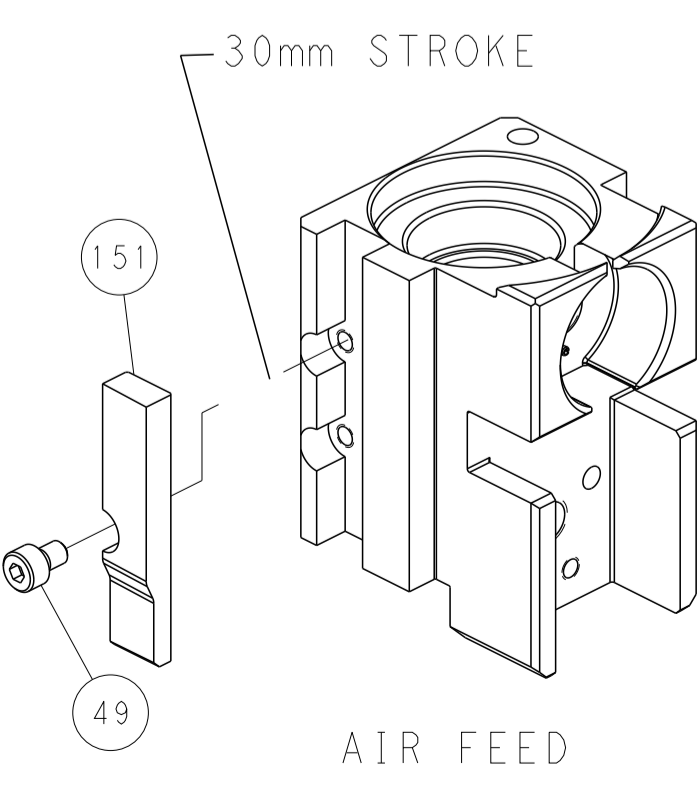
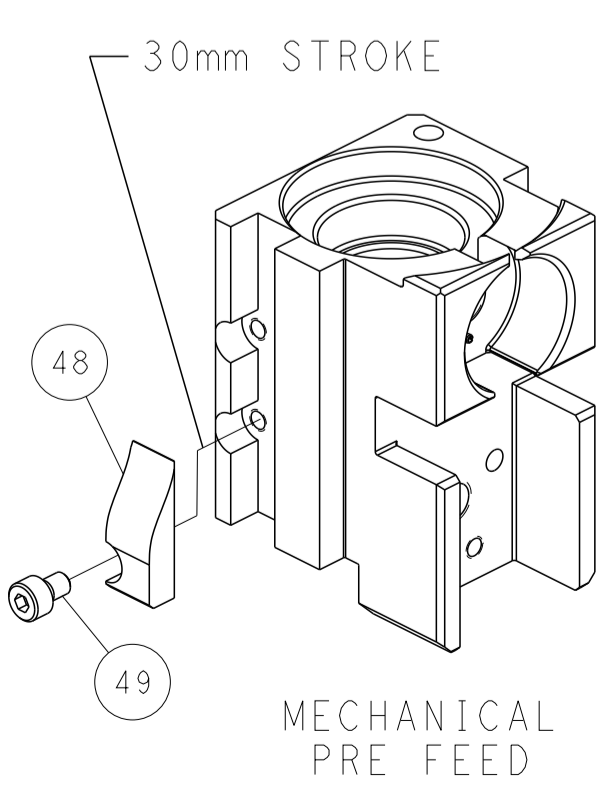
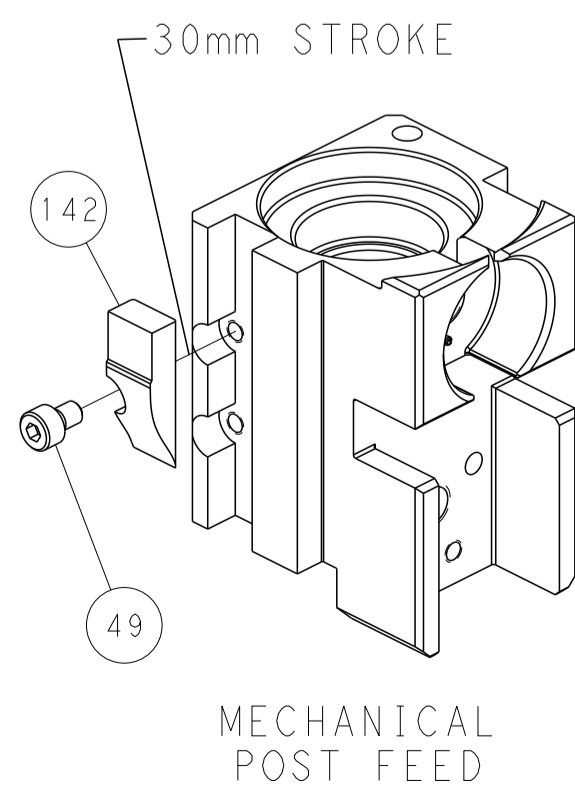

**PACIFIC VERSION**  
 Shown on sheets 3 of 4 & 4 of 4  
 (Atlantic version shown on sheets 1 of 4 & 2 of 4)

<small>THIS DRAWING IS UNPUBLISHED. RELEASED FOR PUBLICATION. ALL RIGHTS RESERVED. © 2003 BY TYCO ELECTRONICS CORPORATION. THIS DRAWING IS CONTROLLED DOCUMENT. ANY REPRODUCTION OR DISTRIBUTION WITHOUT THE WRITTEN PERMISSION OF TYCO ELECTRONICS CORPORATION IS PROHIBITED.</small>		DWN: C. CHEN 20AUG2013 CHK: U. GUO 20AUG2013 APVD: J. CRUZ 20AUG2013	TE Connectivity Harrisburg, PA 17105-3608
DIMENSIONS: mm TOLERANCES UNLESS OTHERWISE SPECIFIED: 0 PLC ± 1 PLC ± 2 PLC ± 3 PLC ± 4 PLC ± ANGLES FINISH		NAME: Ocean Side Feed Applicator APPLICATION SPEC: - SIZE: A1 CAGE CODE: 00779 DRAWING NO: C=2266021 WEIGHT: - CUSTOMER DRAWING: -	RESTRICTED TO: - SCALE: 1:2 SHEET: 4 OF 4 REV: C