

PART NUMBER	REVISION	DESCRIPTION	FEED TYPE
2151808-2	D	FINE CRIMP HEIGHT ADJUST	PNEUMATIC
5-2151808-2	D	SEAL STRIPPER CRIMPER TERMINATING UNIT	PNEUMATIC
7-2151808-2	D	PNEUMATIC AND CRIMP TOOLING KIT	PNEUMATIC
7-2151808-7	A	CRIMP TOOLING KIT	-

ATLANTIC VERSION TERMINATOR INTERFACE ADAPTER

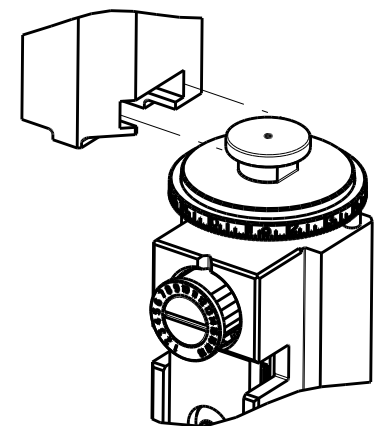

APPLICATOR DATA		
CRIMP	SIZE	TYPE
WIRE	1.58 mm [.062]	F
INSUL	2.30 mm [.091]	F

APPLICATOR INSTRUCTIONS 408-35042

TERMINAL DATA: TE TERMINAL		TE CRIMP SPECIFICATION	
TERMINAL NAME: JUNIOR-TIMER CONTACT			
WIRE STRIP LENGTH		INSULATION DIAMETER RANGE	
3.40-4.00 mm [.134-.157 IN]		Ø1.20-1.60 mm [.047-.063 IN]	
TERMINAL APPLICATION SPECIFICATION	(A)114-18079		
TERMINALS APPLIED			
TE TERMINAL	TE TERMINAL	TE TERMINAL	TE TERMINAL
(A) 927871-1	(A) 927871-2	(A) 927871-4	

TERMINAL DATA: TE TERMINAL		TE CRIMP SPECIFICATION	
TERMINAL NAME: JUNIOR-TIMER CONTACT			
WIRE STRIP LENGTH		INSULATION DIAMETER RANGE	
3.40-4.00 mm [.134-.157 IN]		Ø1.00-1.60 mm [.039-.063 IN]	
TERMINAL APPLICATION SPECIFICATION	(A)114-18079		
	(B)114-18080		
TERMINALS APPLIED			
TE TERMINAL	TE TERMINAL	TE TERMINAL	TE TERMINAL
(B) 926984-1	(B) 926984-2	(B) 1-926984-1	

WIRE SIZE	CRIMP HEIGHT mm [INCH]	CRIMP HEIGHT REFERENCE SETTING
0.50mm2	1.06+/-0.05 [.042+/- .002]	6.9
0.37mm2	0.99+/-0.05 [.039+/- .002]	7.8
0.25mm2	0.93+/-0.05 [.037+/- .002]	8.2
0.20mm2	0.91+/-0.05 [.036+/- .002]	8.4

WIRE SIZE	CRIMP HEIGHT mm [INCH]	CRIMP HEIGHT REFERENCE SETTING
0.50mm2	1.06+/-0.05 [.042+/- .002]	6.9
0.37mm2	0.99+/-0.05 [.039+/- .002]	7.8
0.25mm2	0.93+/-0.05 [.037+/- .002]	8.2
0.20mm2	0.91+/-0.05 [.036+/- .002]	8.4

- RECOMMENDED SPARE PARTS
- REFER TO SUPPLIED INSTRUCTION SHEET FOR CLEANING, LUBRICATION AND STORAGE OF APPLICATOR.
- APPLY PART NUMBER 2-23419-6 LOCTITE TO THREADS OF ITEM 242. APPLY PART NUMBER 1-23419-5 LOCTITE TO THREADS OF ITEM 180.
- CRIMP HEIGHT REFERENCE SETTING WAS THE SETTING USED WHEN THE APPLICATOR WAS QUALIFIED AT THE FACTORY. ADJUSTMENT MAY BE NECESSARY WHEN RUNNING APPLICATOR IN THE FIELD.
- TERMINAL LUBRICANT IS RECOMMENDED.
- 6. UNLESS SPECIFIED OTHERWISE TORQUE VALUES SHALL BE USED PER DOCUMENT, 101-35000.
- TERMINAL PITCH NOT COMPATIBLE WITH MECHANICAL FEED.

***WARNING**
ON INSTALLATION, SET WIRE DISC TO CRIMP HEIGHT REFERENCE SETTING FOR LARGEST WIRE SIZE. CRIMP HEIGHT REFERENCE SETTINGS GREATER THAN THE VALUE SHOWN MAY CAUSE DAMAGE TO THE CRIMP TOOLING. REFER TO THE INSTRUCTION SHEET FOR PROPER SETUP AND ADJUSTMENTS.

LOC	DIST	REVISIONS			
A	66	REV	DATE	BY	APPV
		A	RELEASED	02JAN2013	GH TE
		B	ECR-17-005521	17APR2017	TB TE
		C	ECR-18-013558	26AUG2018	TB TE
		D	ECR-19-009367	14JUN2019	FJ TE

-	-	1	-	1803515-3	RAM ASSEMBLY, SF ATLANTIC	293
-	-	1	-	2-1803583-1	APPLICATOR BASIC ASSEMBLY, SF	292
-	1	1	1	2119641-1	FEED CAM, AIR FEED	248
-	1	1	1	2119082-8	CAM, SNAIL, INSULATION ADJUSTMENT	244
-	1	1	1	2079764-1	WASHER, WAVE SPRING, CREST-TO-CREST	243
-	1	1	1	2119083-1	RETAINER, INSULATION DIAL	242
-	1	1	1	7-18023-7	SCR, SKT HD CAP M3 X 4.0	241
-	1	1	1	2844940-1	AIR FEED MODULE	238
-	-	1	-	4-1722335-3	STRIPPER, SIDE FEED	182
-	-	1	-	1-5018030-0	NUT, HEX, REG, RoHS, M3.5	181
-	-	1	-	2-1752354-0	STANDOFF, HOLD-DOWN	180
-	-	1	-	993111-1	PIN, SLOTTED SPRING 3.0 X 20.0	177
-	-	1	-	5-22280-0	SPRING, COMPRESSION	176
-	-	1	-	1752353-3	GUIDE PIN, HOLDDOWN	175
-	-	1	-	1901680-2	GUIDE PIN, HOLDDOWN	174
-	REF	REF	REF	994970-2	COUNTER, MAGNETIC	164
-	1	1	1	2119955-1	ASSY, LUBRICATOR, SIDE FEED	113
-	1	1	1	2844908-1	SCREW, LOCKING	99
-	1	1	1	2844907-1	POST, LOCKING	98
-	1	1	1	455888-5	SPACER, CRIMPER	82
-	1	1	1	1803607-3	DOCUMENTATION PACKAGE	71
-	1	1	1	2119740-1	TAG, IDENTIFICATION	67
-	2	2	2	2168078-1	SCREW, DRIVE, RH, RoHS, 2 x .188	66
-	1	1	1	2168083-2	SCR, SKT HD CAP, RoHS, M4 X 8.0	60
-	1	1	1	5-18022-5	SCR, HEX HD CAP, M4 X 6.0	59
-	1	1	1	1338685-1	PAWL, FEED	56
-	4	4	4	2168083-3	SCR, SKT HD CAP, RoHS, M4 X 12.0	54
-	2	2	2	2-2168083-5	SCR, SKT HD CAP, RoHS, M4 X 14	53
-	1	1	1	1803382-6	HOLD DOWN, SPRING LOADED	50
-	1	1	1	18023-9	SCR, SKT HD CAP M4 X 6.0	49
-	1	-	1	1803583-9	APPLICATOR BASIC ASSEMBLY, SF	46
-	1	-	1	1803515-1	RAM ASSEMBLY, SF ATLANTIC	44
-	1	1	1	1803602-1	SCR, BHSC, RoHS (M8 X 25)	41
-	1	1	1	1752356-3	SUPPORT, TERMINAL	34
-	2	2	2	2079383-5	SCR, BHSC, RoHS (M4 X 20)	33
-	2	2	2	2-2844962-6	SPACER, CYLINDRICAL, STRIP GUIDE	30
-	1	1	1	2844992-1	ASSEMBLY, STRIP GUIDE	29
-	1	1	1	1-455888-0	SPACER, CRIMPER	28
-	1	1	1	1320928-2	STRIP GUIDE	24
-	1	-	1	2168083-2	SCR, SKT HD CAP, RoHS, M4 X 8.0	21
-	2	1	2	1-18028-2	WASHER, FLAT, REG M4	20
-	1	-	1	2119533-1	STRIPPER, SIDE FEED	19
-	1	1	1	2119806-1	INSERT, SHEAR	13
-	1	1	1	3-22280-3	SPRING, COMPRESSION	12
-	1	1	1	1-356885-4	STOP, SHEAR	11
-	1	1	1	2119805-1	SHEAR HOLDER, FRONT	10
-	1	1	1	1803095-1	FLOATING SHEAR, FRONT	9
-	1	2	1	1-1333202-0	ANVIL, COMBINATION	8
-	1	1	1	240641-5	SPACER	7
-	-	-	-	-	-	6
-	1	1	1	2119757-5	DEPRESSOR, SHEAR	5
-	1	1	1	2-238011-2	BLOCK, CRIMPER SPACER	4
-	1	2	1	1-2119582-1	CRIMPER, INSULATION F PREMIUM	3
-	1	1	1	455888-8	SPACER, CRIMPER	2
-	1	2	1	1-456403-3	CRIMPER, WIRE PREMIUM	1

DIMENSIONS:		TOLERANCES UNLESS OTHERWISE SPECIFIED:		MATERIAL:		FINISH:		WEIGHT:		SCALE:		SHEET:		REV:				
mm	0 PLC ±	1 PLC ±	2 PLC ±	3 PLC ±	4 PLC ±	ANGLES	FINISH			Customer Accessible Production Drawing	SCALE	1:2	SHEET	1	OF	4	REV	D

ATLANTIC VERSION
Shown on sheets 1 of 4 & 2 of 4
(Pacific version shown on sheets 3 of 4 & 4 of 4)

LOC	DIST	REVISIONS					
		P	LTN	DESCRIPTION	DATE	DMN	APVD
A	66	-	-	SEE SHEET 1	-	-	-

FEED TYPE

PNEUMATIC

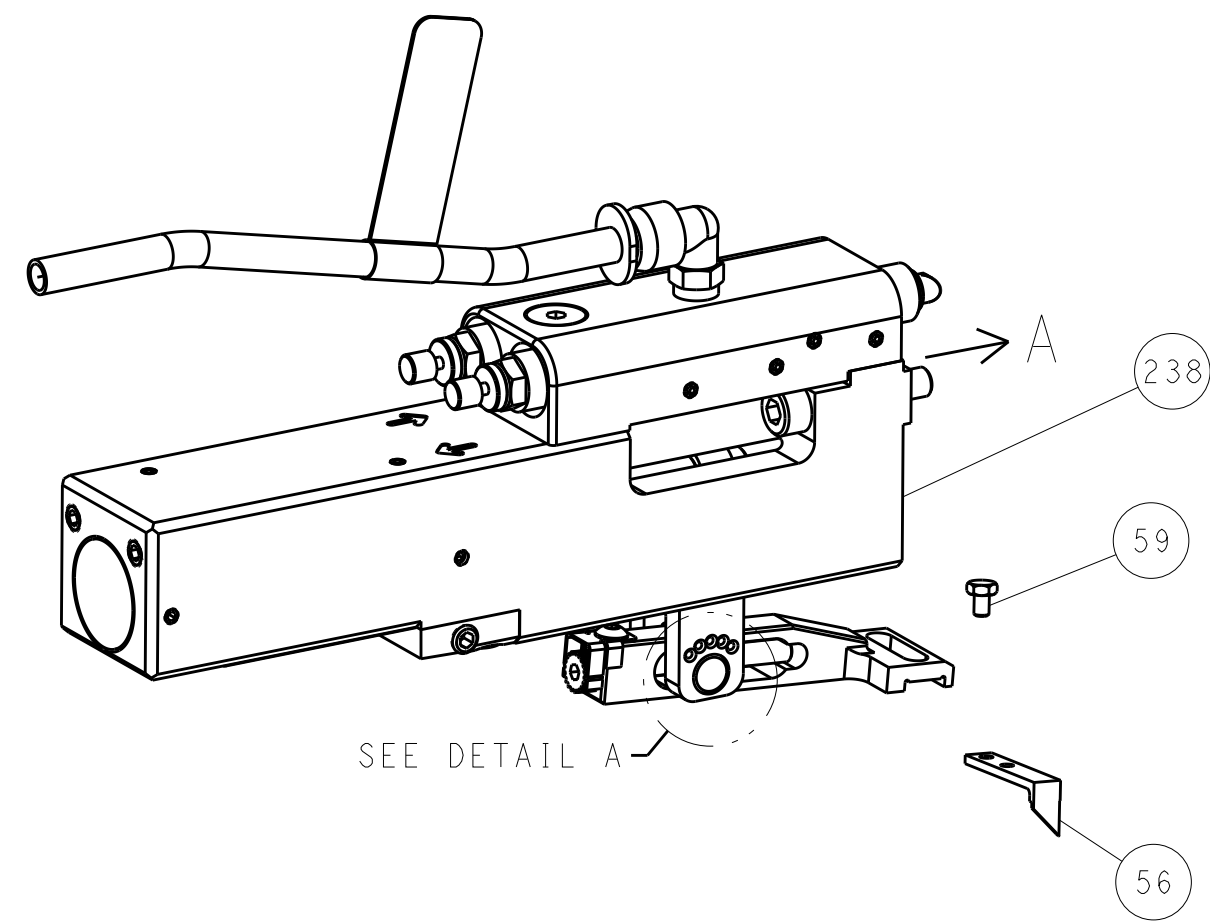

FEED SPRING SETTING POSITION (SHOWN FROM REAR SIDE)

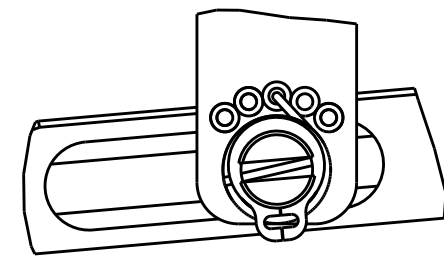

DETAIL A

CAM POSITIONS

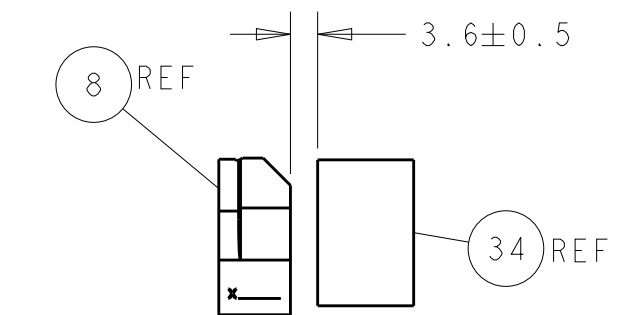
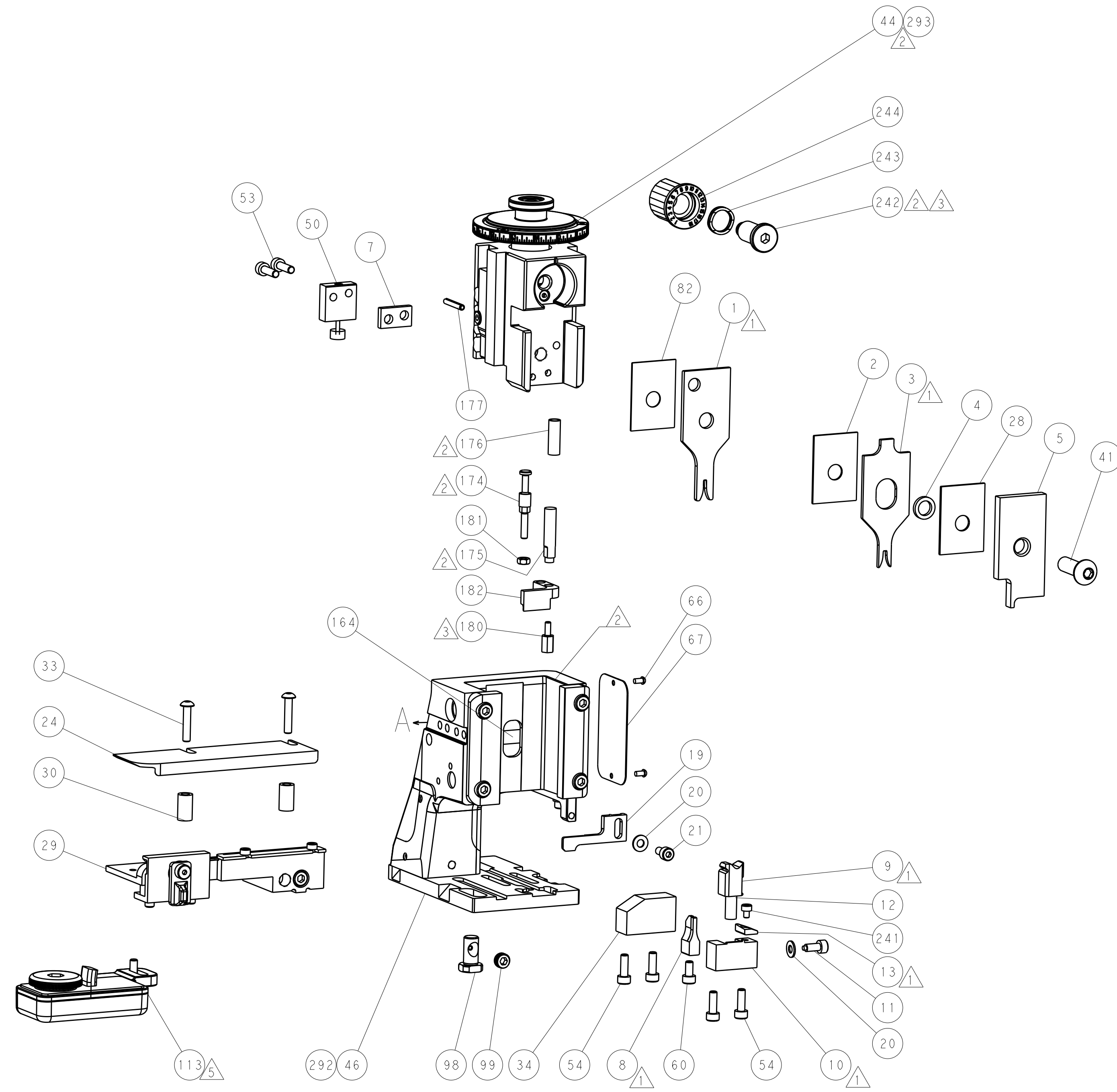
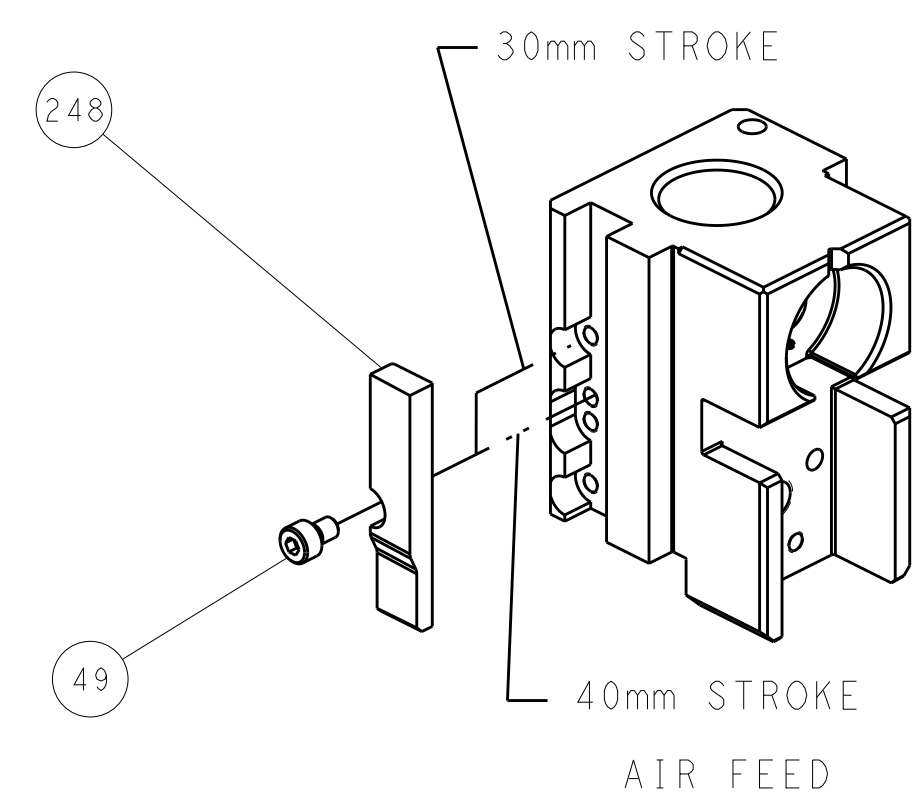

TERMINAL SUPPORT LOCATION

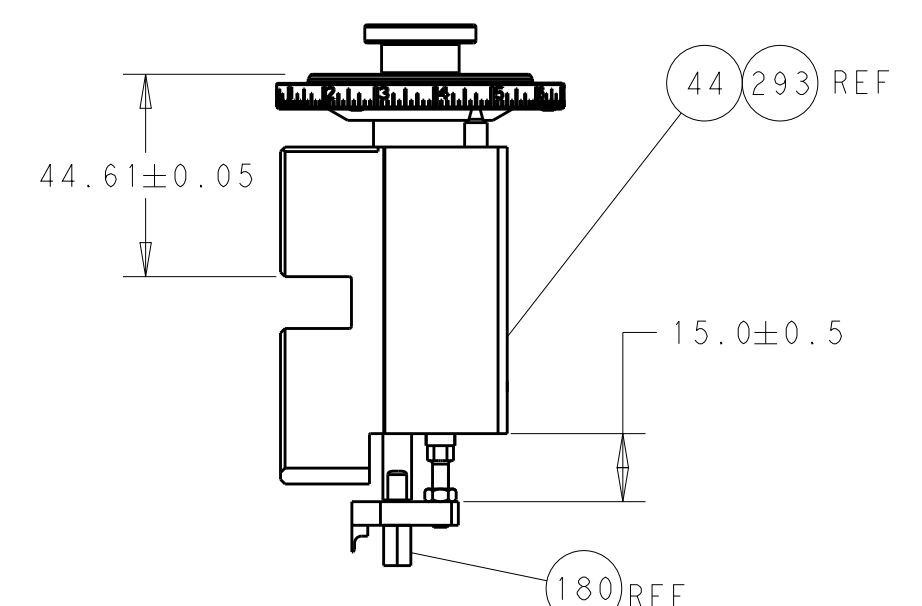

RAM AND HOLDDOWN SET-UP

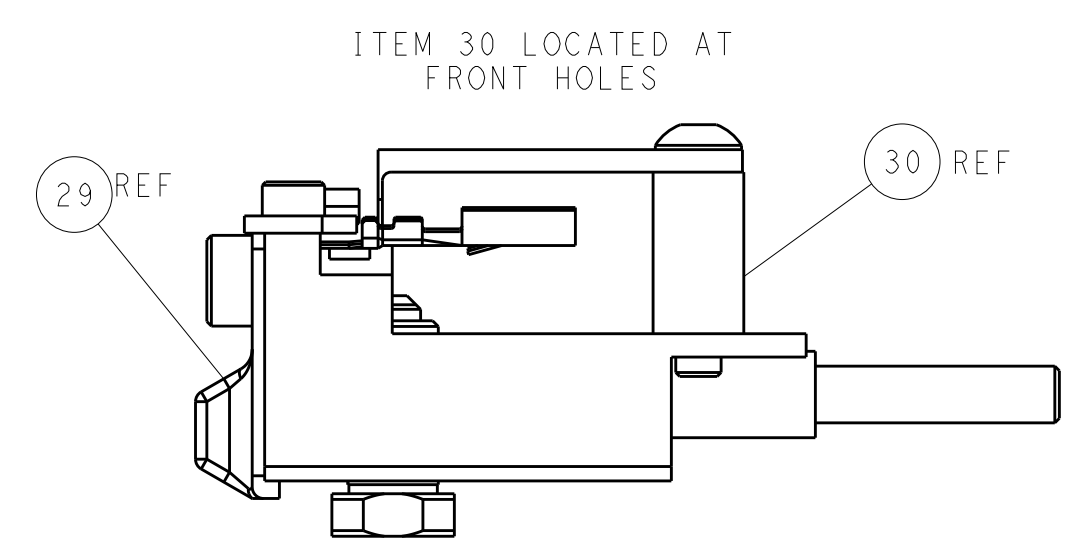

FEED TRACK POSITION GUIDE BY INSULATION BARREL

ATLANTIC VERSION
 Shown on sheets 1 of 4 & 2 of 4
 (Pacific version shown on sheets 3 of 4 & 4 of 4)

DIMENSIONS:		TOLERANCES UNLESS OTHERWISE SPECIFIED:		DWG: HOFFNER 07NOV2012		TE Connectivity	
mm	0 PLC ±	1 PLC ±	2 PLC ±	3 PLC ±	4 PLC ±	Harrisburg, PA 17105-3608	
MATERIAL:		FINISH:		DWG: T. ELBIN 08NOV2012		NAME: Ocean Side Feed Applicator	
Customer Accessible Production Drawing		SCALE: 1:2		SHEET: 2 of 4		REV: D	

PART NUMBER	REVISION	DESCRIPTION	FEED TYPE
2-2151808-2	D	FINE CRIMP HEIGHT ADJUST	PNEUMATIC
7-2151808-7	A	CRIMP TOOLING KIT	-

PACIFIC VERSION TERMINATOR
 INTERFACE ADAPTER

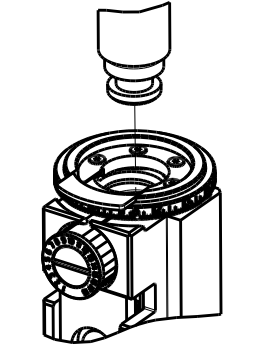

APPLICATOR DATA		
CRIMP	SIZE	TYPE
WIRE	1.58 mm [.062]	F
INSUL	2.30 mm [.091]	F

APPLICATOR INSTRUCTIONS
 408-35042

TERMINAL DATA: TE TERMINAL		TE CRIMP SPECIFICATION	
TERMINAL NAME: JUNIOR-TIMER CONTACT			
WIRE STRIP LENGTH		INSULATION DIAMETER RANGE	
3.40-4.00 mm [.134-.157 IN]		Ø1.20-1.60 mm [.047-.063 IN]	
TERMINAL APPLICATION SPECIFICATION	(A)114-18079	-	-
TERMINALS APPLIED			
TE TERMINAL	TE TERMINAL	TE TERMINAL	TE TERMINAL
(A) 927871-1	(A) 927871-2	(A) 927871-4	

TERMINAL DATA: TE TERMINAL		TE CRIMP SPECIFICATION	
TERMINAL NAME: JUNIOR-TIMER CONTACT			
WIRE STRIP LENGTH		INSULATION DIAMETER RANGE	
3.40-4.00 mm [.134-.157 IN]		Ø1.00-1.60 mm [.039-.063 IN]	
TERMINAL APPLICATION SPECIFICATION	(B)114-18080	-	-
TERMINALS APPLIED			
TE TERMINAL	TE TERMINAL	TE TERMINAL	TE TERMINAL
(B) 926984-1	(B) 926984-2	(B) 1-926984-1	

WIRE SIZE	CRIMP HEIGHT mm [INCH]	CRIMP HEIGHT REFERENCE SETTING
0.50mm2	1.06+/-0.05 [.042+/-0.002]	6.9
0.37mm2	0.99+/-0.05 [.039+/-0.002]	7.8
0.25mm2	0.93+/-0.05 [.037+/-0.002]	8.2
0.20mm2	0.91+/-0.05 [.036+/-0.002]	8.4

WIRE SIZE	CRIMP HEIGHT mm [INCH]	CRIMP HEIGHT REFERENCE SETTING
0.50mm2	1.06+/-0.05 [.042+/-0.002]	6.9
0.37mm2	0.99+/-0.05 [.039+/-0.002]	7.8
0.25mm2	0.93+/-0.05 [.037+/-0.002]	8.2
0.20mm2	0.91+/-0.05 [.036+/-0.002]	8.4

- RECOMMENDED SPARE PARTS
- REFER TO SUPPLIED INSTRUCTION SHEET FOR CLEANING, LUBRICATION AND STORAGE OF APPLICATOR.
- APPLY PART NUMBER 2-23419-6 LOCTITE TO THREADS OF ITEM 242.
- CRIMP HEIGHT REFERENCE SETTING WAS THE SETTING USED WHEN THE APPLICATOR WAS QUALIFIED AT THE FACTORY. ADJUSTMENT MAY BE NECESSARY WHEN RUNNING APPLICATOR IN THE FIELD.
- TERMINAL LUBRICANT IS RECOMMENDED.
- 6. UNLESS SPECIFIED OTHERWISE TORQUE VALUES SHALL BE USED PER DOCUMENT, 101-35000.
- TERMINAL PITCH NOT COMPATIBLE WITH MECHANICAL FEED.

***WARNING**
 ON INSTALLATION, SET WIRE DISC TO CRIMP HEIGHT REFERENCE SETTING FOR LARGEST WIRE SIZE. CRIMP HEIGHT REFERENCE SETTINGS GREATER THAN THE VALUE SHOWN MAY CAUSE DAMAGE TO THE CRIMP TOOLING. REFER TO THE INSTRUCTION SHEET FOR PROPER SETUP AND ADJUSTMENTS.

LOC	DIST	REVISIONS					
		P	LTN	DESCRIPTION	DATE	OWN	APVD
A	66	-	-	SEE SHEET 1	-	-	-

-	1	2119082-8	CAM, SNAIL, INSULATION ADJUSTMENT	244	
-	1	2079764-1	WASHER, WAVE SPRING, CREST-TO-CREST	243	
-	1	2119083-1	RETAINER, INSULATION DIAL	242	
-	1	7-18023-7	SCR, SKT HD CAP M3 X 4.0	241	
-	1	2844940-1	AIR FEED MODULE	238	
-	REF	994970-2	COUNTER, MAGNETIC	164	
-	1	2119641-2	FEED CAM, AIR FEED	151	
-	1	2168083-8	SCR, SKT HD CAP, RoHS, M4 X 16	144	
-	4	2168083-9	SCR, SKT HD CAP, RoHS, M4 X 20	143	
-	1	1-1803583-0	APPLICATOR BASIC ASSEMBLY, SF	141	
-	1	1803516-1	RAM ASSEMBLY, SF PACIFIC	140	
-	1	2119955-1	ASSY, LUBRICATOR, SIDE FEED	113	
-	1	2844908-1	SCREW, LOCKING	99	
-	1	2844907-1	POST, LOCKING	98	
-	1	455888-5	SPACER, CRIMPER	82	
-	1	1803607-3	DOCUMENTATION PACKAGE	71	
-	1	2119740-1	TAG, IDENTIFICATION	67	
-	2	2168078-1	SCREW, DRIVE, RH, RoHS, 2 x .188	66	
-	1	5-18022-5	SCR, HEX HD CAP, M4 X 6.0	59	
-	1	1338685-1	PAWL, FEED	56	
-	2	2-2168083-5	SCR, SKT HD CAP, RoHS, M4 X 14	53	
-	1	1803382-6	HOLD DOWN, SPRING LOADED	50	
-	1	18023-9	SCR, SKT HD CAP M4 X 6.0	49	
-	1	1803602-1	SCR, BHSC, RoHS (M8 X 25)	41	
-	1	1752356-3	SUPPORT, TERMINAL	34	
-	2	2079383-5	SCR, BHSC, RoHS (M4 X 20)	33	
-	2	2-2844962-6	SPACER, CYLINDRICAL, STRIP GUIDE	30	
-	1	2844992-1	ASSEMBLY, STRIP GUIDE	29	
-	1	1-455888-0	SPACER, CRIMPER	28	
-	1	1320928-2	STRIP GUIDE	24	
-	1	2168083-2	SCR, SKT HD CAP, RoHS, M4 X 8.0	21	
-	2	1-18028-2	WASHER, FLAT, REG M4	20	
-	1	2119533-1	STRIPPER, SIDE FEED	19	
-	1	2119806-1	INSERT, SHEAR	13	
-	1	3-22280-3	SPRING, COMPRESSION	12	
-	1	1-356885-4	STOP, SHEAR	11	
-	1	2119805-1	SHEAR HOLDER, FRONT	10	
-	1	1803095-1	FLOATING SHEAR, FRONT	9	
-	1	1-1333202-0	ANVIL, COMBINATION	8	
-	1	240641-5	SPACER	7	
-	-	-	-	6	
-	1	2119757-5	DEPRESSOR, SHEAR	5	
-	1	2-238011-2	BLOCK, CRIMPER SPACER	4	
-	1	1-2119582-1	CRIMPER, INSULATION F PREMIUM	3	
-	1	455888-8	SPACER, CRIMPER	2	
-	1	1-456403-3	CRIMPER, WIRE PREMIUM	1	
-	77	-22	PART NO	DESCRIPTION	ITEM NO

PACIFIC VERSION
 Shown on sheets 3 of 4 & 4 of 4
 (Atlantic version shown on sheets 1 of 4 & 2 of 4)

DIMENSIONS: mm		TOLERANCES UNLESS OTHERWISE SPECIFIED:		DWG: HOFFNER 07NOV2012		CHK: T. ELBIN 08NOV2012		APVD: T. ELBIN 08NOV2012		NAME: Ocean Side Feed Applicator	
0 PLC ±		1 PLC ±		2 PLC ±		3 PLC ±		4 PLC ±		SIZE: A1	
ANGLES		FINISH		WEIGHT		SCALE: 1:2		SHEET: 3 OF 4		REV: D	
MATERIAL		FINISH		WEIGHT		SCALE: 1:2		SHEET: 3 OF 4		REV: D	

Customer Accessible Production Drawing

LOC		DIST		REVISIONS			
A		66		REV	DATE	BY	APP'D
-				SEE SHEET 1	-	-	-

FEED TYPE

PNEUMATIC

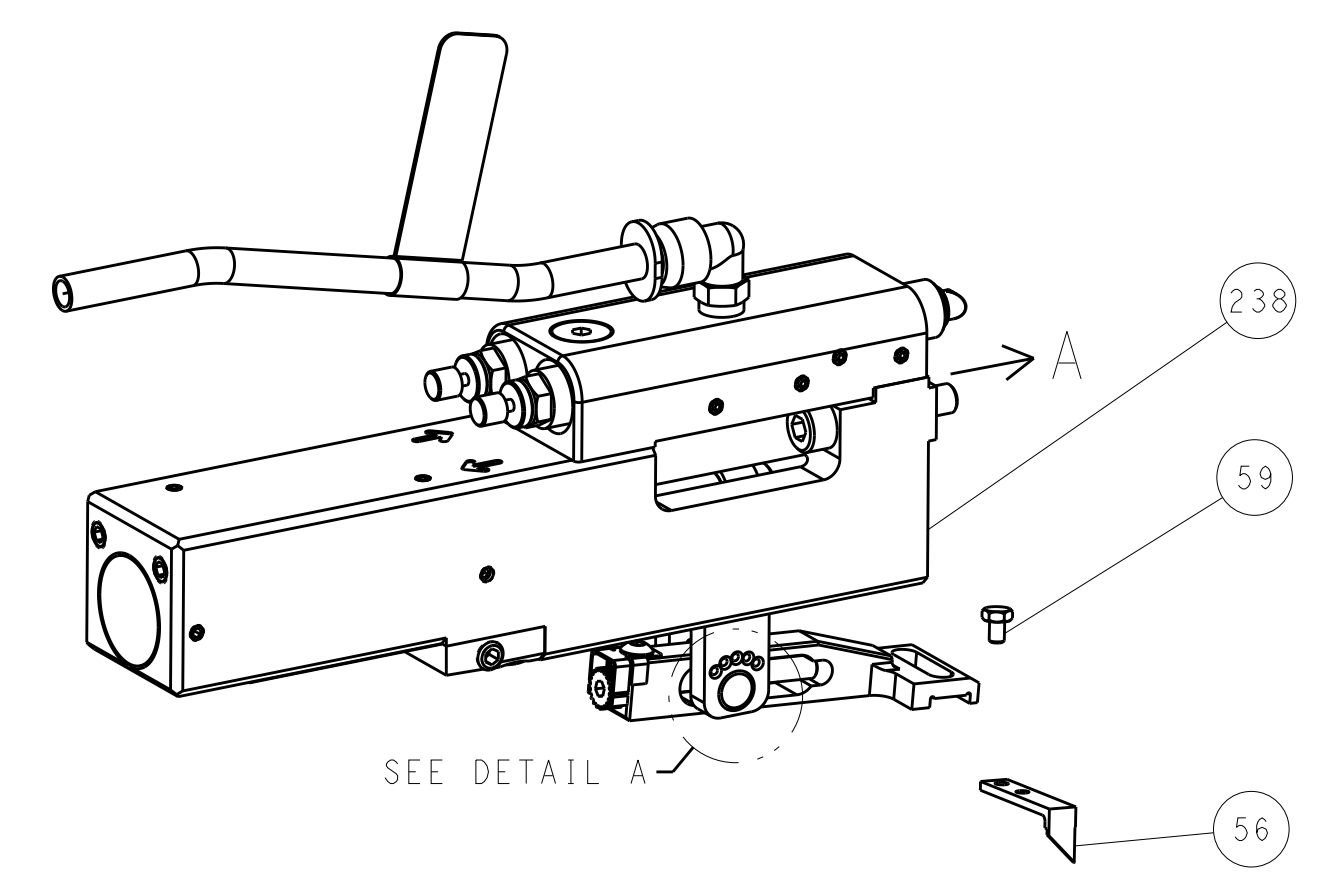

SEE DETAIL A

FEED SPRING SETTING POSITION (SHOWN FROM REAR SIDE)

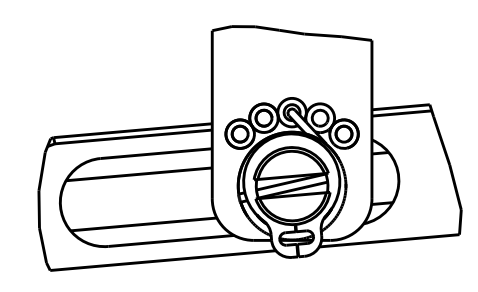

DETAIL A

CAM POSITIONS

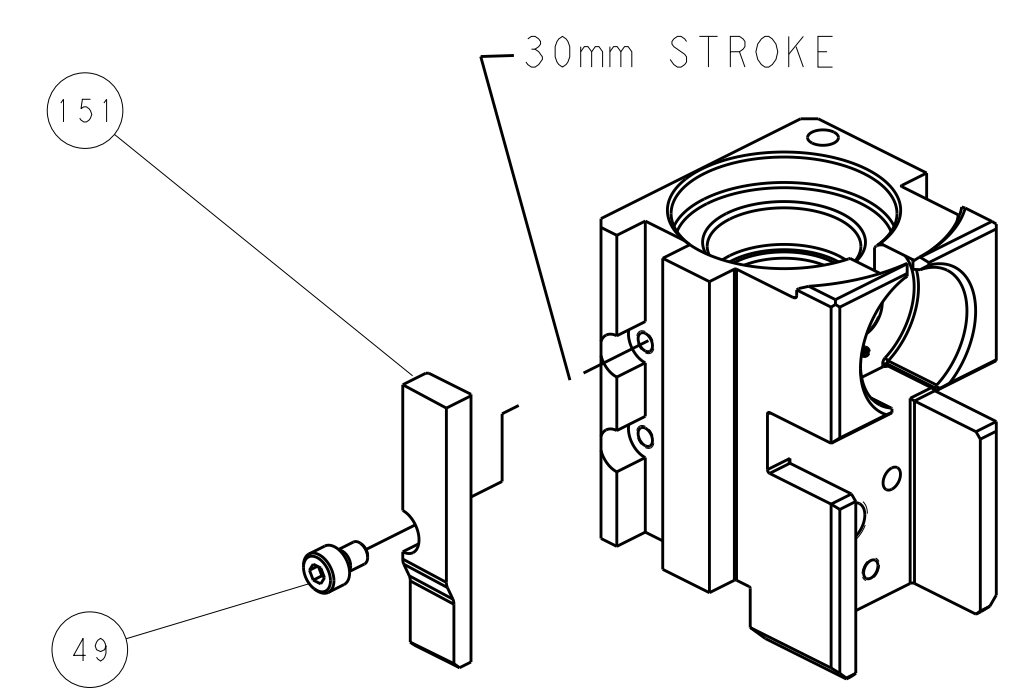

AIR FEED

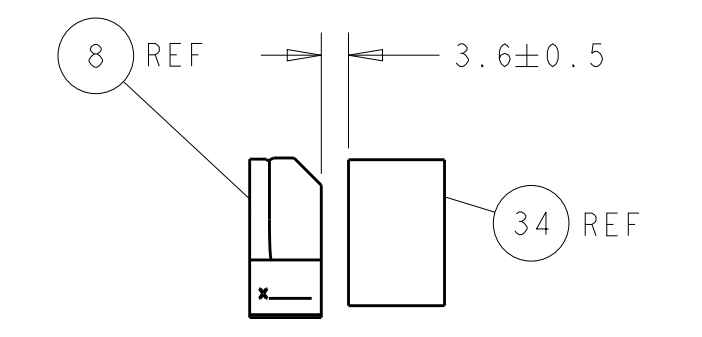
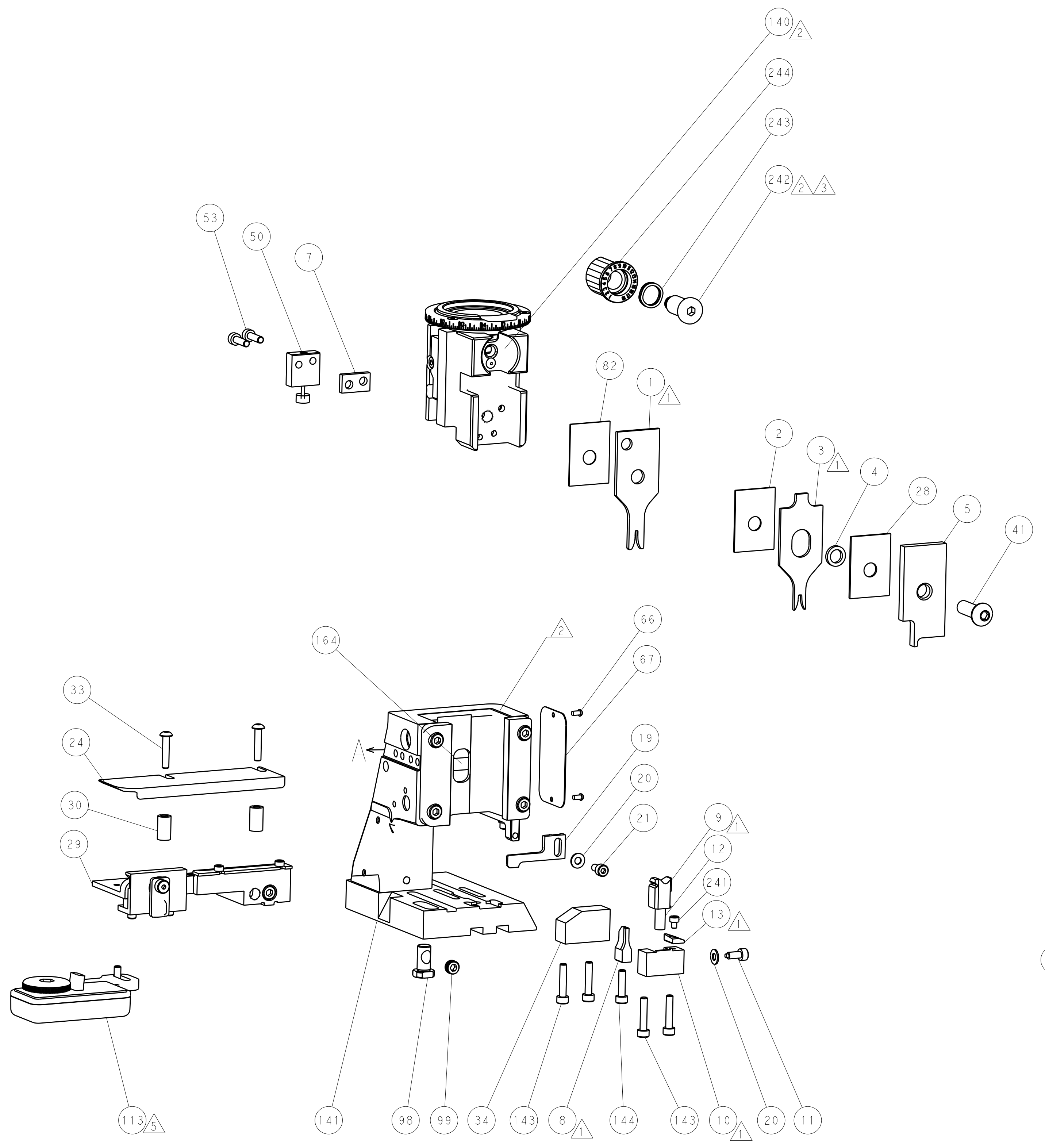

TERMINAL SUPPORT LOCATION

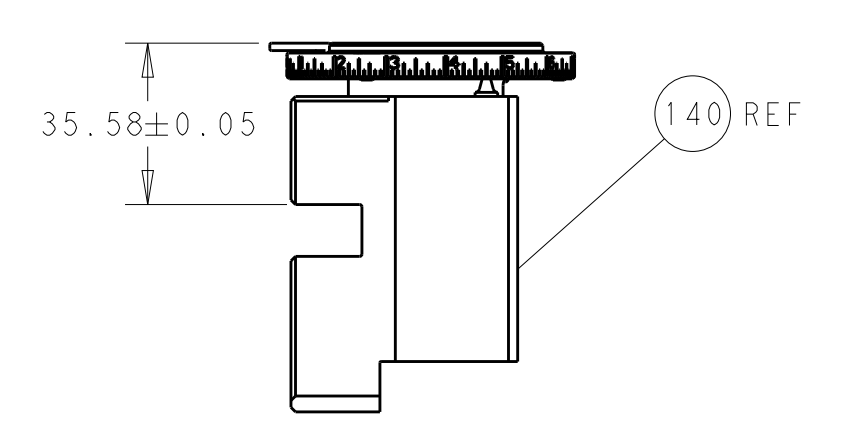

RAM SET-UP

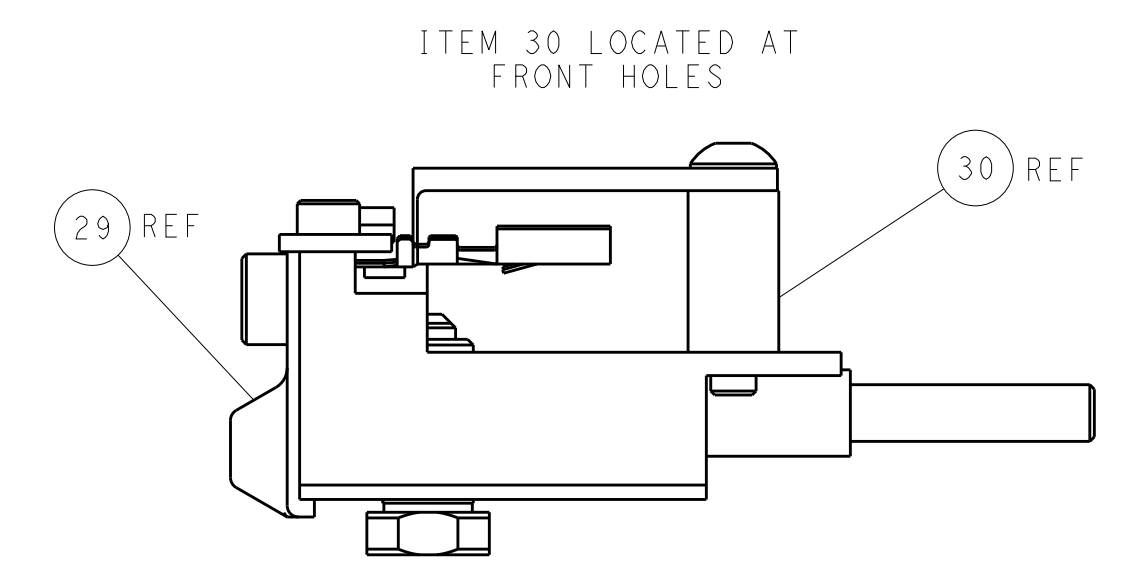

FEED TRACK POSITION GUIDE BY INSULATION BARREL

PACIFIC VERSION
 Shown on sheets 3 of 4 & 4 of 4
 (Atlantic version shown on sheets 1 of 4 & 2 of 4)

<small>THIS DRAWING IS UNPUBLISHED. RELEASED FOR PUBLICATION. IT IS THE PROPERTY OF TYCO ELECTRONICS CORPORATION. IT IS TO BE USED ONLY FOR THE PROJECT AND ORGANIZATION FOR WHICH IT WAS PREPARED. IT IS NOT TO BE REPRODUCED OR TRANSMITTED IN ANY FORM OR BY ANY MEANS, ELECTRONIC OR MECHANICAL, INCLUDING PHOTOCOPYING, RECORDING, OR BY ANY INFORMATION STORAGE AND RETRIEVAL SYSTEM, WITHOUT THE WRITTEN PERMISSION OF TYCO ELECTRONICS CORPORATION.</small>		DWN: HOFFNER 07NOV2012 CHK: T. ELBIN 08NOV2012 APVD: T. ELBIN 08NOV2012	TE Connectivity Harrisburg, PA 17105-3608
DIMENSIONS: mm TOLERANCES UNLESS OTHERWISE SPECIFIED: 0 PLC ± 1 PLC ± 2 PLC ± 3 PLC ± 4 PLC ± ANGLES ±		NAME: Ocean Side Feed Applicator PRODUCT SPEC: APPLICATION SPEC: SIZE: A1 CAGE CODE: 00779 DRAWING NO: C=2151808	RESTRICTED TO: SCALE: 1:2 SHEET: 4 OF 4 REV: D
MATERIAL: - FINISH: -		WEIGHT: - Customer Accessible Production Drawing	SHEETS 1 & 2 ARE NOT REQUIRED FOR PACIFIC VERSION