

ATLANTIC VERSION TERMINATOR  
 INTERFACE ADAPTER



PART NUMBER	REVISION	DESCRIPTION	FEED TYPE
2151204-1	C	FINE CRIMP HEIGHT ADJUST	MECHANICAL
2151204-2	D	FINE CRIMP HEIGHT ADJUST	PNEUMATIC
5-2151204-1	C	SEAL STRIPPER CRIMPER TERMINATING UNIT	MECHANICAL
5-2151204-2	D	SEAL STRIPPER CRIMPER TERMINATING UNIT	PNEUMATIC
7-2151204-1	C	MECHANICAL AND CRIMP TOOLING KIT	MECHANICAL
7-2151204-2	D	PNEUMATIC AND CRIMP TOOLING KIT	PNEUMATIC
7-2151204-7	A	CRIMP TOOLING KIT	-

APPLICATOR DATA		
CRIMP	SIZE	TYPE
WIRE	2.29 mm [.090]	F
INSUL	3.68 mm [.145]	O

APPLICATOR INSTRUCTIONS  
 408-35042

TERMINAL DATA: TE TERMINAL		TE CRIMP SPECIFICATION	
TERMINAL NAME: MINI MIC TAB CTC.			
WIRE STRIP LENGTH		INSULATION DIAMETER RANGE	
3.00-3.50 mm [.118-.138 IN]		Ø1.70-3.30 mm [.067-.130 IN]	
TERMINAL APPLICATION SPECIFICATION	114-20045		
TERMINALS APPLIED			
TE TERMINAL	TE TERMINAL	TE SEAL	TE SEAL
282109-1	282109-4		281934-2
282109-2	282109-5		281934-3
282109-3			

SEAL INSULATION DIAMETER RANGE
Ø1.7-2.4mm
Ø2.5-3.3mm

WIRE SIZE	CRIMP HEIGHT mm [INCH]	CRIMP HEIGHT REFERENCE SETTING
1.50mm2	1.52+/-0.05 [.060+/- .002]	9.7
1.00mm2	1.45+/-0.05 [.057+/- .002]	10.3
0.75mm2	1.34+/-0.05 [.053+/- .002]	11.6

- 1. RECOMMENDED SPARE PARTS
- 2. REFER TO SUPPLIED INSTRUCTION SHEET FOR CLEANING, LUBRICATION & STORAGE OF APPLICATOR.
- 3. APPLY PART NUMBER 1-23419-5 LOCTITE TO THREADS OF ITEM 180. APPLY PART NUMBER 2-23419-6 LOCTITE TO THREADS OF ITEM 242.
- 4. CRIMP HEIGHT REFERENCE SETTING WAS THE SETTING USED WHEN THE APPLICATOR WAS QUALIFIED AT THE FACTORY. ADJUSTMENT MAY BE NECESSARY WHEN RUNNING APPLICATOR IN THE FIELD.
- 5. APPLY TORO-SEAL IN ALLEN SOCKET TO FILL HOLE AFTER FLAT HD HAS BEEN ADJUSTED TO CORRECT HEIGHT AT QUALIFICATION. APPLY #1-23419-5 LOC-TITE TO THREADS.
- 6. UNLESS SPECIFIED OTHERWISE TORQUE VALUES SHALL BE USED PER DOCUMENT 101-35000.

**\*WARNING**  
 ON INSTALLATION, SET WIRE DISC TO CRIMP HEIGHT REFERENCE SETTING FOR LARGEST WIRE SIZE. CRIMP HEIGHT REFERENCE SETTINGS GREATER THAN THE VALUE SHOWN MAY CAUSE DAMAGE TO THE CRIMP TOOLING, REFER TO THE INSTRUCTION SHEET FOR PROPER SETUP AND ADJUSTMENTS.

**ATLANTIC VERSION**  
 Shown on sheets 1 of 4 & 2 of 4  
 (Pacific version shown on sheets 3 of 4 & 4 of 4)

LOC	DIST	REVISIONS					
A	66	P	LTN	DESCRIPTION	DATE	OWN	APVD
		A		RELEASED	05APR2013	LG	GB
		B		ECR-13-009635	13JUN2013	YY	UG
		C		ECR-18-009225	13JUN2018	LG	JD
		D		ECR-19-009012	08JUN2019	TB	TE

-	-	-	1	1	-	-	1803515-3	RAM ASSEMBLY, SF ATLANTIC	293
-	-	-	1	1	-	-	2-1803583-1	APPLICATOR BASIC ASSEMBLY, SF	292
-	1	-	1	-	1	-	2119641-1	FEED CAM, AIR FEED	248
-	1	1	1	1	1	1	2119082-7	CAM, SNAIL, INSULATION ADJUSTMENT	244
-	1	1	1	1	1	1	2079764-1	WASHER, WAVE SPRING, CREST-TO-CREST	243
3	-	1	1	1	1	1	2119083-1	RETAINER, INSULATION DIAL	242
-	1	1	1	1	1	1	7-18023-7	SCR, SKT HD CAP M3 X 4.0	241
-	-	1	-	1	-	1	2119580-1	MECHANICAL FEED ASSEMBLY	239
-	1	-	1	-	1	-	2844940-1	AIR FEED MODULE	238
-	-	-	1	1	-	-	4-1722335-3	STRIPPER, SIDE FEED	182
3	-	-	-	1	1	-	1-5018030-0	NUT, HEX, REG, RoHS, M3.5	181
-	-	-	-	1	1	-	1-1752354-9	STANDOFF, HOLD-DOWN	180
-	-	-	-	1	1	-	993111-1	PIN, SLOTTED SPRING 3.0 X 20.0	177
-	-	-	-	1	1	-	5-22280-0	SPRING, COMPRESSION	176
-	-	-	-	1	1	-	1752353-3	GUIDE PIN, HOLDDOWN	175
-	-	-	-	1	1	-	1901680-2	GUIDE PIN, HOLDDOWN	174
-	REF	REF	REF	REF	REF	REF	994970-2	COUNTER, MAGNETIC	164
-	1	1	1	1	1	1	1-18028-2	WASHER, FLAT, REG M4	119
-	1	1	1	1	1	1	2844908-1	SCREW, LOCKING	99
-	1	1	1	1	1	1	2844907-1	POST, LOCKING	98
-	1	1	1	1	1	1	455888-5	SPACER, CRIMPER	82
-	1	1	1	1	1	1	1803607-3	DOCUMENTATION PACKAGE	71
-	1	1	1	1	1	1	2119740-1	TAG, IDENTIFICATION	67
-	2	2	2	2	2	2	2168078-1	SCREW, DRIVE, RH, RoHS, 2 x .188	66
-	1	1	1	1	1	1	2168083-2	SCR, SKT HD CAP, RoHS, M4 X 8.0	60
-	1	1	1	1	1	1	5-18022-5	SCR, HEX HD CAP, M4 X 6.0	59
5	-	1	1	1	1	1	985575-3	SCR, FLT SKT HD CAP M3 X 10.0	57
-	1	1	1	1	1	1	1338685-1	PAWL, FEED	56
-	4	4	4	4	4	4	2168083-3	SCR, SKT HD CAP, RoHS, M4 X 12.0	54
-	2	2	2	2	2	2	2168083-8	SCR, SKT HD CAP, RoHS, M4 X 16	53
-	1	1	1	1	1	1	5018030-1	NUT, HEX, REG, RoHS, M3	52
-	1	1	1	1	1	1	811242-5	BUMPER, HOLD DOWN	51
-	1	1	1	1	1	1	690753-2	SPACER, TONKER	50
-	1	2	1	2	1	2	18023-9	SCR, SKT HD CAP M4 X 6.0	49
-	-	1	-	1	-	1	2119652-1	FEED CAM, PRE FEED	48
-	-	1	-	1	-	1	2119653-1	FEED CAM, POST FEED	47
-	1	1	-	-	1	1	1803583-9	APPLICATOR BASIC ASSEMBLY, SF	46
-	1	1	-	-	1	1	1803515-1	RAM ASSEMBLY, SF ATLANTIC	44
-	1	1	1	1	1	1	1803602-1	SCR, BHSC, RoHS (M8 X 25)	41
-	1	1	1	1	1	1	1-1752356-9	SUPPORT, TERMINAL	34
-	2	2	2	2	2	2	2079383-5	SCR, BHSC, RoHS (M4 X 20)	33
-	2	2	2	2	2	2	2-2844962-8	SPACER, CYLINDRICAL, STRIP GUIDE	30
-	1	1	1	1	1	1	2844992-1	ASSEMBLY, STRIP GUIDE	29
-	1	1	1	1	1	1	455888-5	SPACER, CRIMPER	28
-	1	1	1	1	1	1	1320928-2	STRIP GUIDE	24
-	1	1	-	-	1	1	2168083-2	SCR, SKT HD CAP, RoHS, M4 X 8.0	21
-	2	2	1	1	2	2	1-18028-2	WASHER, FLAT, REG M4	20
-	1	1	-	-	1	1	2119533-1	STRIPPER, SIDE FEED	19
1	-	1	1	1	1	1	2119806-1	INSERT, SHEAR	13
-	1	1	1	1	1	1	3-22280-3	SPRING, COMPRESSION	12
-	1	1	1	1	1	1	1-356885-4	STOP, SHEAR	11
-	1	1	1	1	1	1	2119805-1	SHEAR HOLDER, FRONT	10
-	1	1	1	1	1	1	318707-1	FLOATING SHEAR, FRONT	9
1	2	2	1	1	1	1	2-1333205-1	ANVIL, COMBINATION	8
-	1	1	1	1	1	1	2-240641-0	SPACER	7
-	-	-	-	-	-	-	-	-	6
-	1	1	1	1	1	1	2119781-1	DEPRESSOR, SHEAR	5
-	1	1	1	1	1	1	2-238011-2	BLOCK, CRIMPER SPACER	4
1	2	2	1	1	1	1	3-2119784-8	CRIMPER, INSULATION O PREMIUM	3
-	1	1	1	1	1	1	1-455888-0	SPACER, CRIMPER	2
1	2	2	1	1	1	1	2-456406-9	CRIMPER, WIRE PREMIUM	1

ITEM NO	PART NO	DESCRIPTION	ITEM NO
-77	-72	-71	-52
-51	-2	-1	

DATE	11MAR2013	CHKD	T. ELBIN	DATE	12MAR2013	CHKD	T. ELBIN
DATE	12MAR2013	APVD	T. ELBIN	DATE	12MAR2013	APVD	T. ELBIN

DIMENSIONS:	TOLERANCES UNLESS OTHERWISE SPECIFIED:	NAME	Ocean Side Feed Applicator
mm	0 PLC ±.1	SIZE	A1
	1 PLC ±.15	CAGE CODE	00779
	2 PLC ±.2	DRAWING NO	2151204
	3 PLC ±.3	RESTRICTED TO	
	4 PLC ±.4	WEIGHT	
	ANGLES ±.5	SCALE	1:2
	FINISH	SHEET	1 OF 4
MATERIAL		REV	D

Customer Accessible Production Drawing

LOC	DIST	REVISIONS					
A	66	P	LTN	DESCRIPTION	DATE	OWN	APVD
		-		SEE SHEET 1	-	-	-

# FEED TYPE MECHANICAL

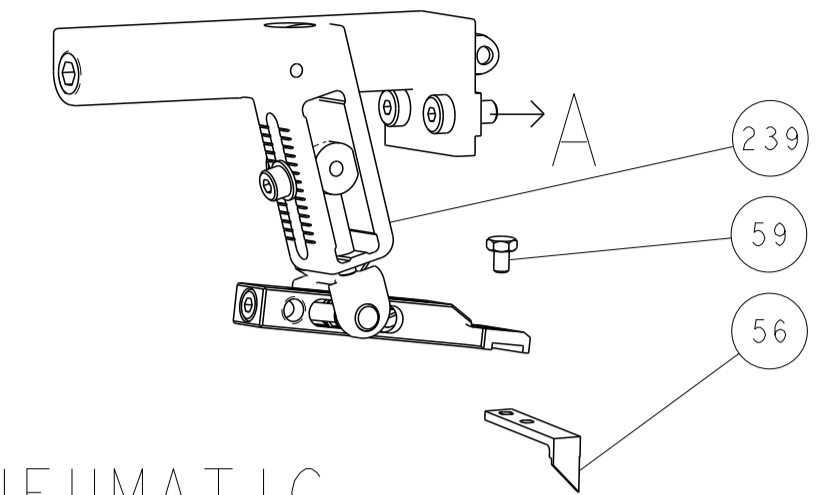

## PNEUMATIC

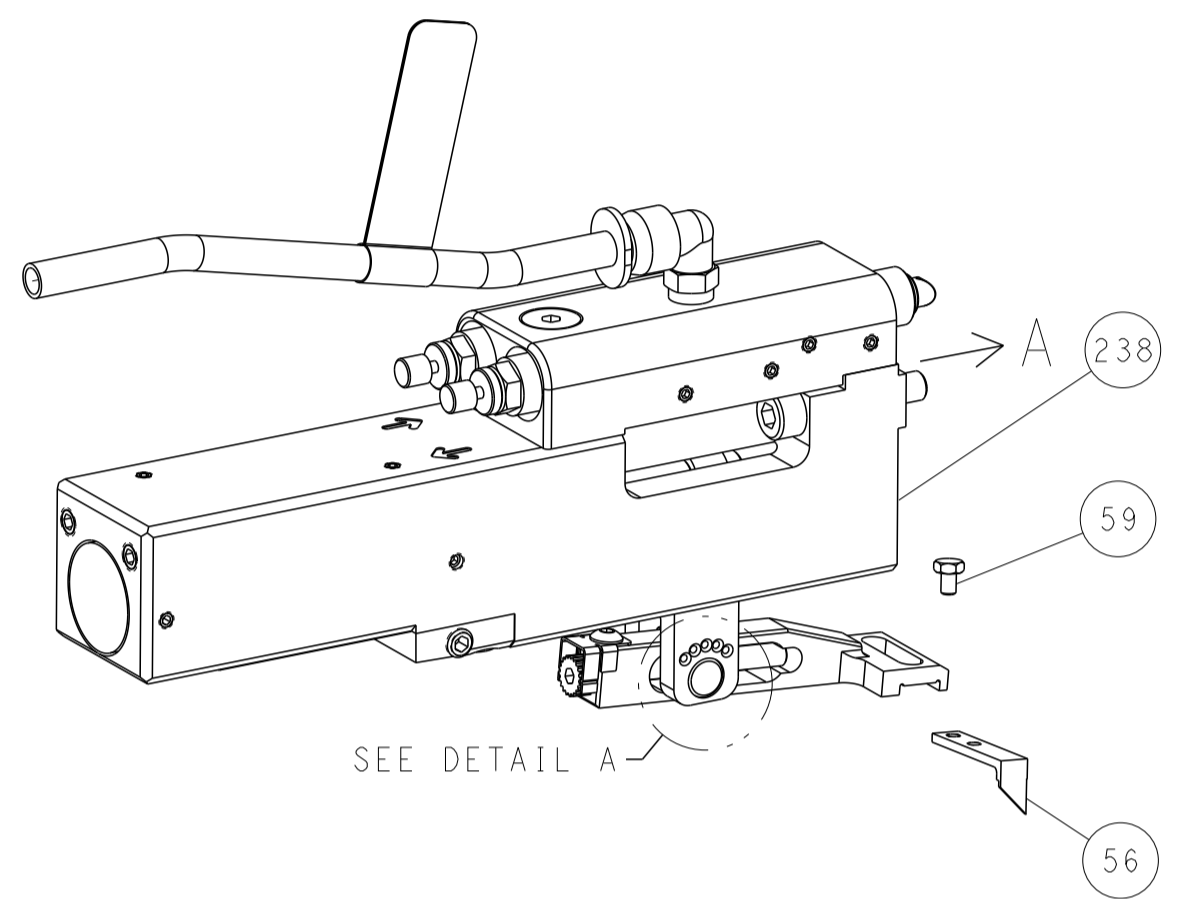

## FEED SPRING SETTING POSITION (SHOWN FROM REAR SIDE)

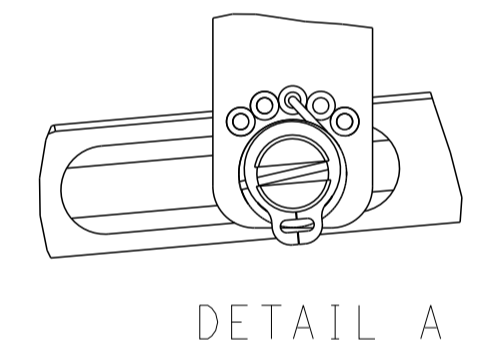

# CAM POSITIONS

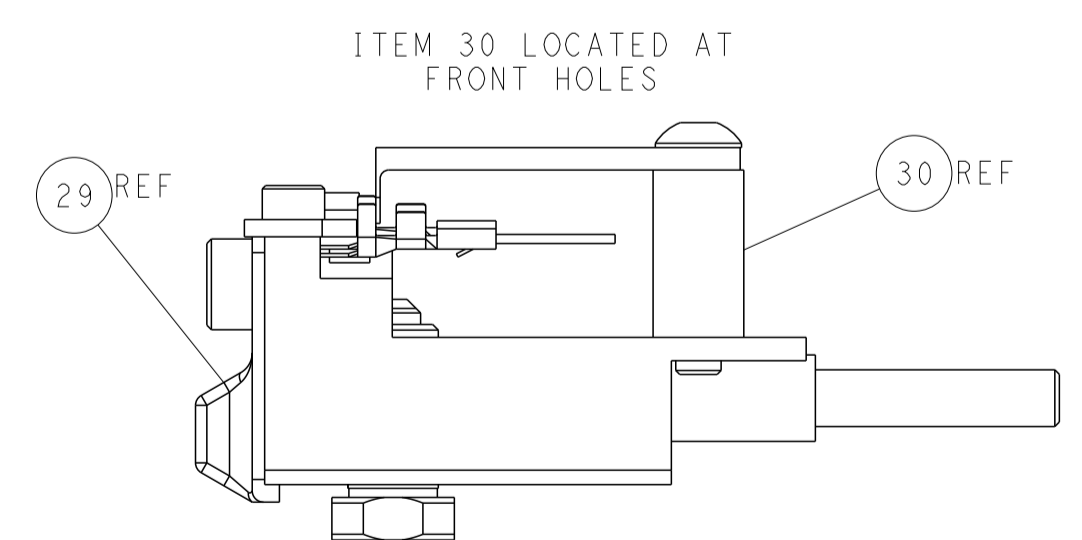
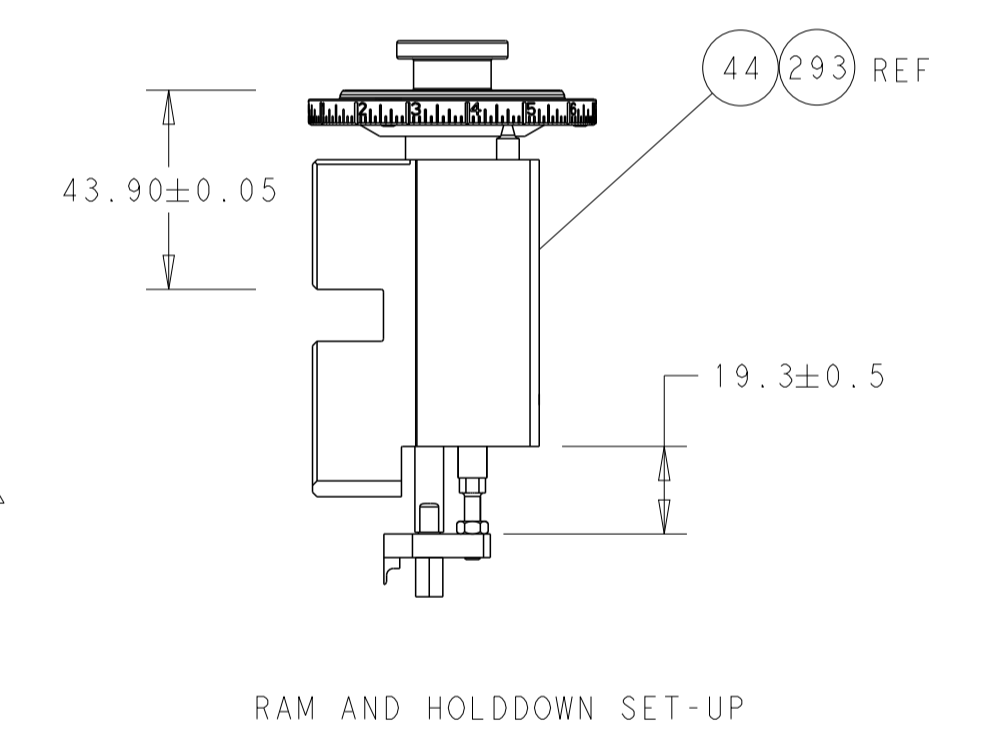
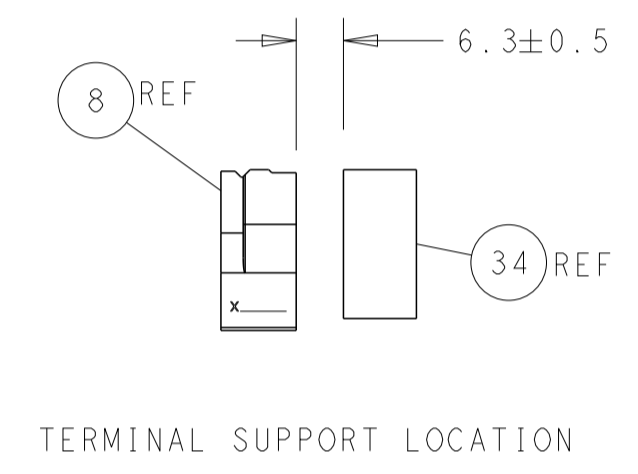
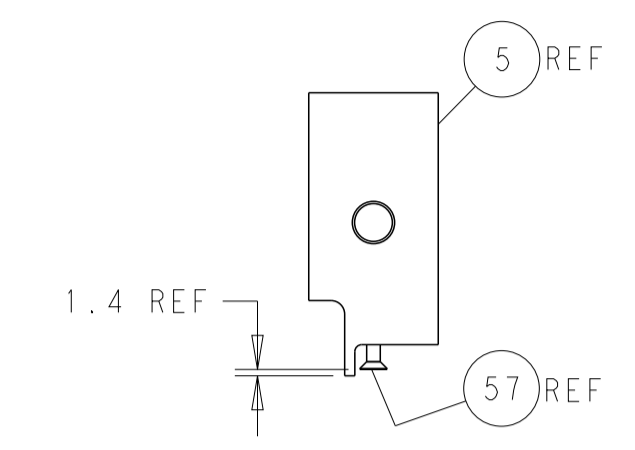
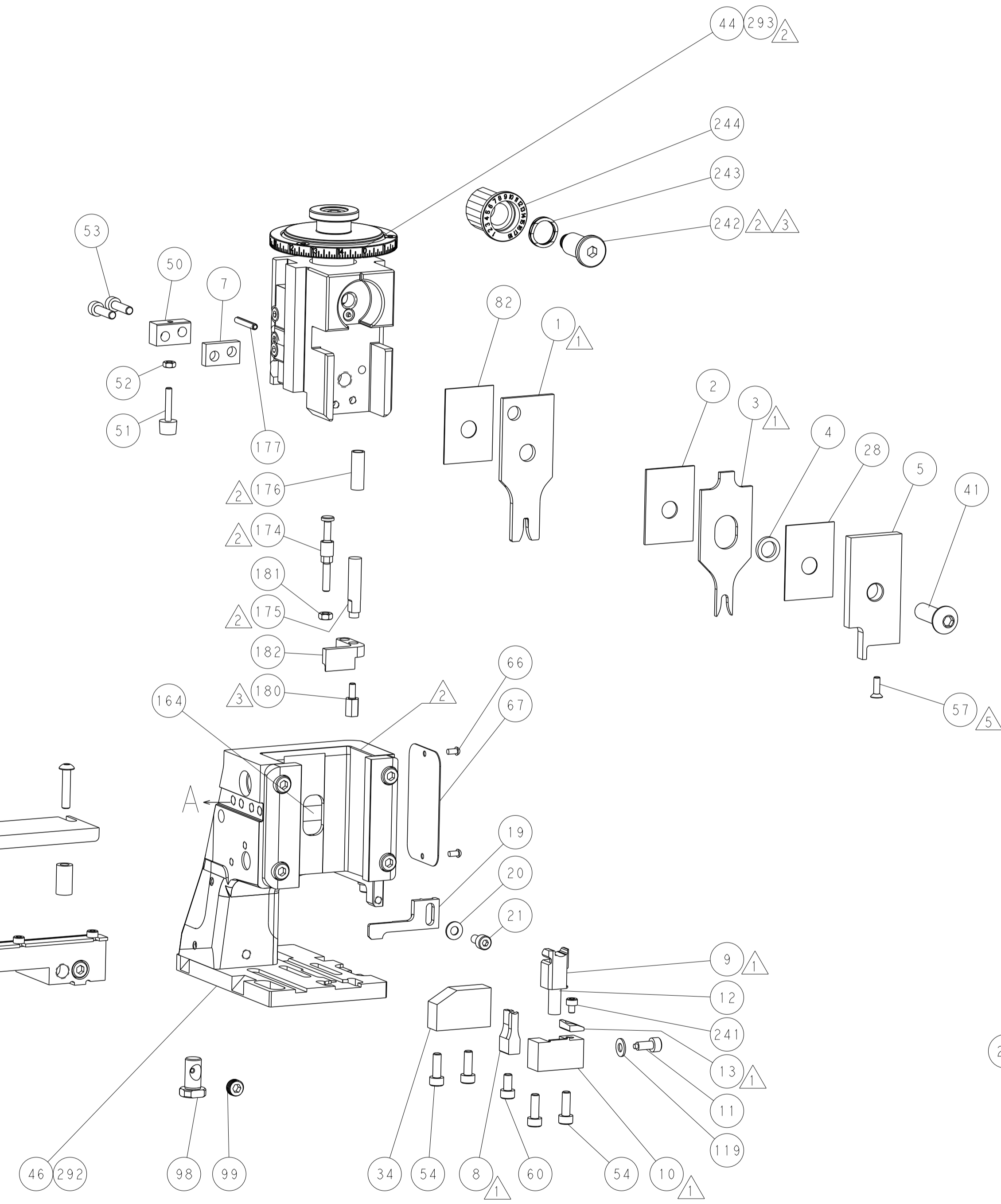
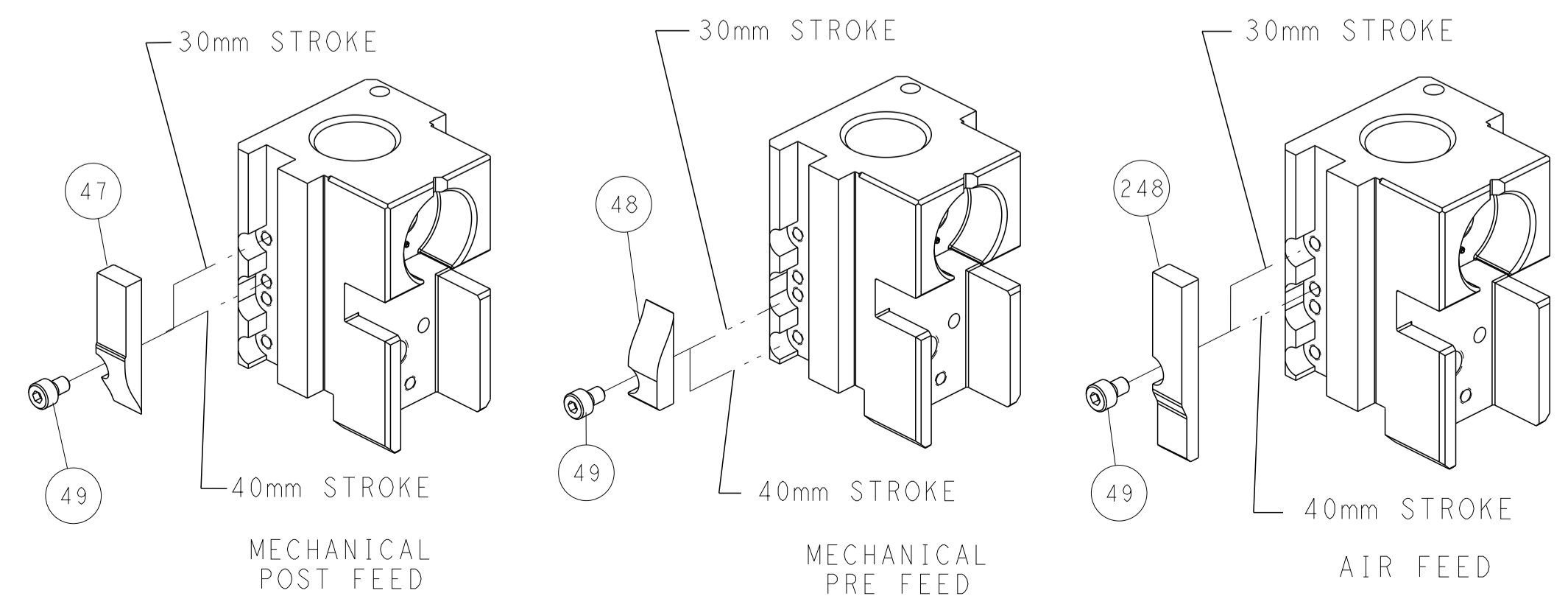

**ATLANTIC VERSION**  
 Shown on sheets 1 of 4 & 2 of 4  
 (Pacific version shown on sheets 3 of 4 & 4 of 4)

DIMENSIONS:		TOLERANCES UNLESS OTHERWISE SPECIFIED:		DWN: HOFFNER 11MAR2013		TE Connectivity	
mm	0 PLC ±	1 PLC ±	2 PLC ±	3 PLC ±	4 PLC ±	Harrisburg, PA 17105-3608	
MATERIAL:		FINISH:		APVD: T. ELBIN 12MAR2013		NAME: Ocean Side Feed Applicator	
				PRODUCT SPEC:		SIZE: CAGE CODE: DRAWING NO:	
				APPLICATION SPEC:		RESTRICTED TO:	
				WEIGHT:		A1 00779 ©=2151204	
				Customer Accessible Production Drawing		SCALE: 1:2 SHEET 2 OF 4 REV D	

PART NUMBER	REVISION	DESCRIPTION	FEED TYPE
2-2151204-1	C	FINE CRIMP HEIGHT ADJUST	MECHANICAL
2-2151204-2	D	FINE CRIMP HEIGHT ADJUST	PNEUMATIC
7-2151204-7	A	CRIMP TOOLING KIT	-

PACIFIC VERSION TERMINATOR  
INTERFACE ADAPTER



APPLICATOR DATA		
CRIMP	SIZE	TYPE
WIRE	2.29 mm [.090]	F
INSUL	3.68 mm [.145]	O

APPLICATOR INSTRUCTIONS  
408-35042

TERMINAL DATA: TE TERMINAL		TE CRIMP SPECIFICATION	
TERMINAL NAME: MINI MIC TAB CTC.			
WIRE STRIP LENGTH		INSULATION DIAMETER RANGE	
3.00-3.50 mm [.118-.138 IN]		∅1.70-3.30 mm [.067-.130 IN]	
TERMINAL APPLICATION SPECIFICATION	114-20045	-	-
TERMINALS APPLIED			
TE TERMINAL	TE TERMINAL	TE SEAL	TE SEAL
282109-1	282109-4		281934-2
282109-2	282109-5		281934-3
282109-3			

WIRE SIZE	CRIMP HEIGHT mm [INCH]	CRIMP HEIGHT REFERENCE SETTING
1.50mm2	1.52+/-0.05 [.060+/-0.002]	9.7
1.00mm2	1.45+/-0.05 [.057+/-0.002]	10.3
0.75mm2	1.34+/-0.05 [.053+/-0.002]	11.6

- RECOMMENDED SPARE PARTS
  - REFER TO SUPPLIED INSTRUCTION SHEET FOR CLEANING, LUBRICATION & STORAGE OF APPLICATOR.
  - APPLY PART NUMBER 2-23419-6 LOCTITE TO THREADS OF ITEM 242.
  - CRIMP HEIGHT REFERENCE SETTING WAS THE SETTING USED WHEN THE APPLICATOR WAS QUALIFIED AT THE FACTORY. ADJUSTMENT MAY BE NECESSARY WHEN RUNNING APPLICATOR IN THE FIELD.
  - APPLY TORO-SEAL IN ALLEN SOCKET TO FILL HOLE AFTER FLAT HD HAS BEEN ADJUSTED TO CORRECT HEIGHT AT QUALIFICATION. APPLY #1-23419-5 LOC-TITE TO THREADS.
6. UNLESS SPECIFIED OTHERWISE TORQUE VALUES SHALL BE USED PER DOCUMENT 101-35000.

**\*WARNING**  
ON INSTALLATION, SET WIRE DISC TO CRIMP HEIGHT REFERENCE SETTING FOR LARGEST WIRE SIZE. CRIMP HEIGHT REFERENCE SETTINGS GREATER THAN THE VALUE SHOWN MAY CAUSE DAMAGE TO THE CRIMP TOOLING, REFER TO THE INSTRUCTION SHEET FOR PROPER SETUP AND ADJUSTMENTS.

PACIFIC VERSION  
Shown on sheets 3 of 4 & 4 of 4  
(Atlantic version shown on sheets 1 of 4 & 2 of 4)

LOC	DIST	REVISIONS					
A	66	P	LTN	DESCRIPTION	DATE	OWN	APVD
-	-	-	-	SEE SHEET 1	-	-	-

-	1	1	2119082-7	CAM, SNAIL, INSULATION ADJUSTMENT	244
-	1	1	2079764-1	WASHER, WAVE SPRING, CREST-TO-CREST	243
-	1	1	2119083-1	RETAINER, INSULATION DIAL	242
-	1	1	7-18023-7	SCR, SKT HD CAP M3 X 4.0	241
-	-	1	2119580-1	MECHANICAL FEED ASSEMBLY	239
-	-	1	2844940-1	AIR FEED MODULE	238
-	REF	REF	994970-2	COUNTER, MAGNETIC	164
-	1	-	2119641-2	FEED CAM, AIR FEED	151
-	1	1	2168083-8	SCR, SKT HD CAP, RoHS, M4 X 16	144
-	4	4	2168083-9	SCR, SKT HD CAP, RoHS, M4 X 20	143
-	-	1	2119653-2	FEED CAM, POST FEED	142
-	1	1	1-1803583-0	APPLICATOR BASIC ASSEMBLY, SF	141
-	1	1	1803516-1	RAM ASSEMBLY, SF PACIFIC	140
-	1	1	1-18028-2	WASHER, FLAT, REG M4	119
-	1	1	2844908-1	SCREW, LOCKING	99
-	1	1	2844907-1	POST, LOCKING	98
-	1	1	455888-5	SPACER, CRIMPER	82
-	1	1	1803607-3	DOCUMENTATION PACKAGE	71
-	1	1	2119740-1	TAG IDENTIFICATION	67
-	2	2	2168078-1	SCREW, DRIVE, RH, RoHS, 2 x .188	66
-	1	1	5-18022-5	SCR, HEX HD CAP, M4 X 6.0	59
-	1	1	985575-3	SCR, FLT SKT HD CAP M3 X 10.0	57
-	1	1	1338685-1	PAWL, FEED	56
-	2	2	2168083-8	SCR, SKT HD CAP, RoHS, M4 X 16	53
-	1	1	5018030-1	NUT, HEX, REG, RoHS, M3	52
-	1	1	811242-5	BUMPER, HOLD DOWN	51
-	1	1	690753-2	SPACER, TONKER	50
-	1	2	18023-9	SCR, SKT HD CAP M4 X 6.0	49
-	-	1	2119652-1	FEED CAM, PRE FEED	48
-	1	1	1803602-1	SCR, BHSC, RoHS (M8 X 25)	41
-	1	1	1-1752356-9	SUPPORT, TERMINAL	34
-	2	2	2079383-5	SCR, BHSC, RoHS (M4 X 20)	33
-	2	2	2-2844962-8	SPACER, CYLINDRICAL, STRIP GUIDE	30
-	1	1	2844992-1	ASSEMBLY, STRIP GUIDE	29
-	1	1	455888-5	SPACER, CRIMPER	28
-	1	1	1320928-2	STRIP GUIDE	24
-	1	1	2168083-2	SCR, SKT HD CAP, RoHS, M4 X 8.0	21
-	1	1	1-18028-2	WASHER, FLAT, REG M4	20
-	1	1	2119533-1	STRIPPER, SIDE FEED	19
-	1	1	2119806-1	INSERT, SHEAR	13
-	1	1	3-22280-3	SPRING, COMPRESSION	12
-	1	1	1-356885-4	STOP, SHEAR	11
-	1	1	2119805-1	SHEAR HOLDER, FRONT	10
-	1	1	318707-1	FLOATING SHEAR, FRONT	9
-	1	1	2-1333205-1	ANVIL, COMBINATION	8
-	1	1	2-240641-0	SPACER	7
-	-	-	-	-	6
-	1	1	2119781-1	DEPRESSOR, SHEAR	5
-	1	1	2-238011-2	BLOCK, CRIMPER SPACER	4
-	1	1	3-2119784-8	CRIMPER, INSULATION O PREMIUM	3
-	1	1	1-455888-0	SPACER, CRIMPER	2
-	1	1	2-456406-9	CRIMPER, WIRE PREMIUM	1

DIMENSIONS:		TOLERANCES UNLESS OTHERWISE SPECIFIED:		MATERIAL:		FINISH:	
mm	0 PLC ±	1 PLC ±	2 PLC ±	3 PLC ±	4 PLC ±	ANGLES	FINISH

OWN	CHK	APVD	DATE	NAME	SIZE	CAGE CODE	DRAWING NO	RESTRICTED TO
HOFFNER	T. ELBIN	T. ELBIN	12MAR2013	Ocean Side Feed Applicator	A1	00779	2151204	-

Customer Accessible Production Drawing SCALE 1:2 SHEET 3 OF 4 REV D

LOC	DIST	REVISIONS					
A	66	P	LTN	DESCRIPTION	DATE	OWN	APVD
		-		SEE SHEET 1			

# FEED TYPE MECHANICAL

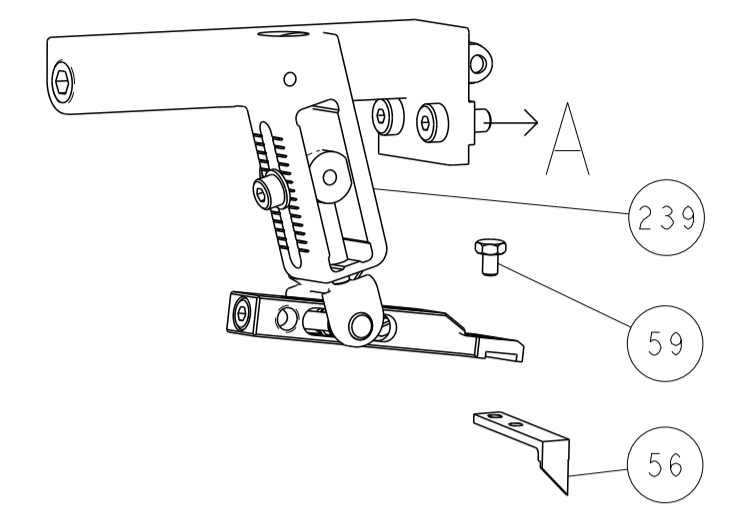

## PNEUMATIC

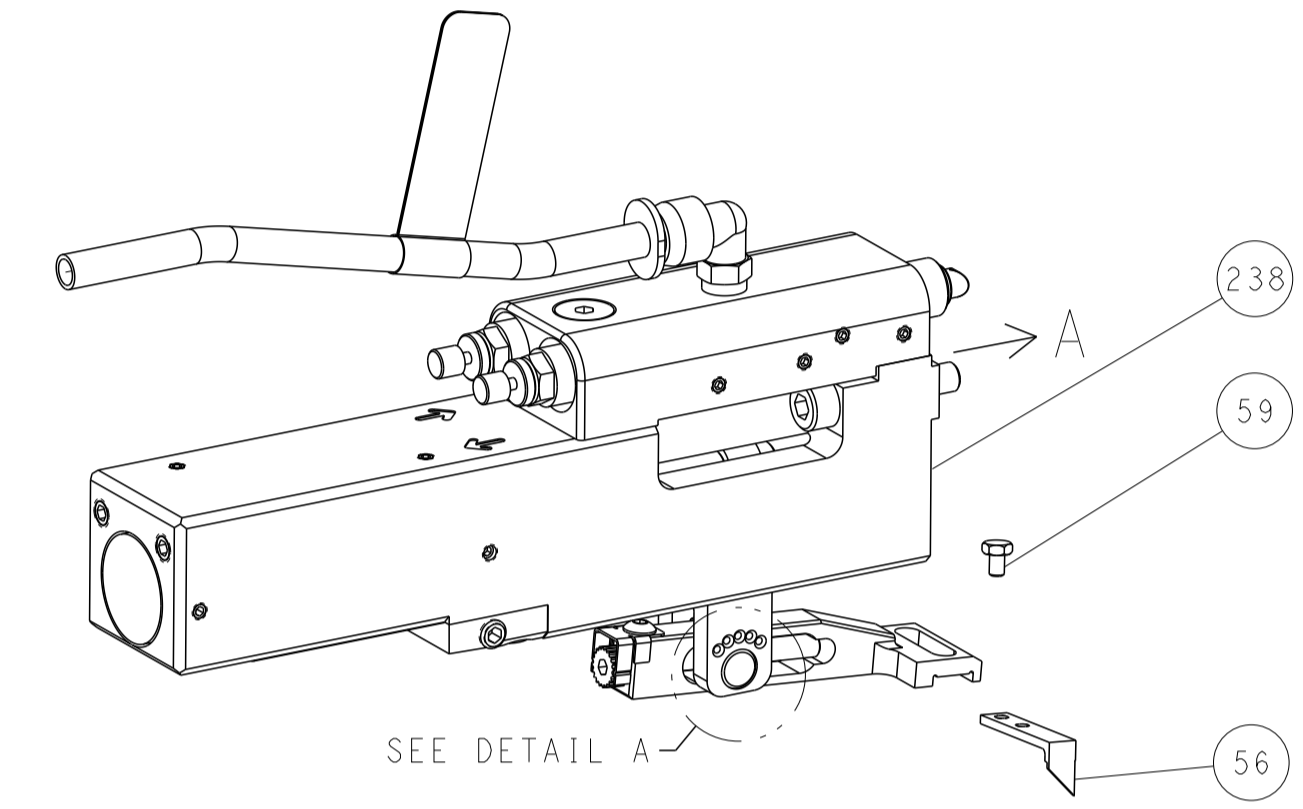

### FEED SPRING SETTING POSITION (SHOWN FROM REAR SIDE)

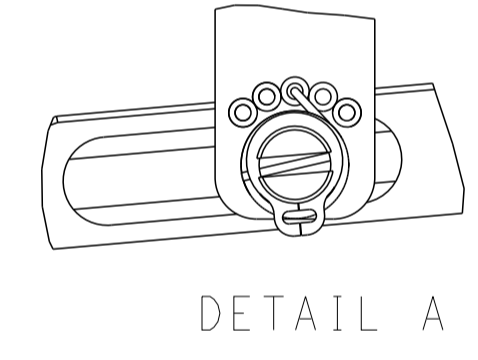

## CAM POSITIONS

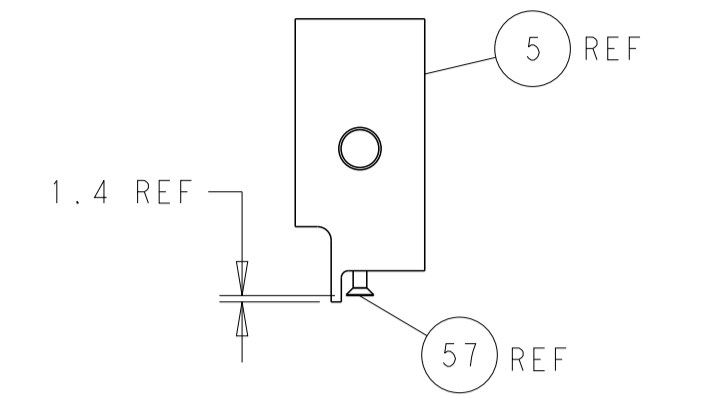
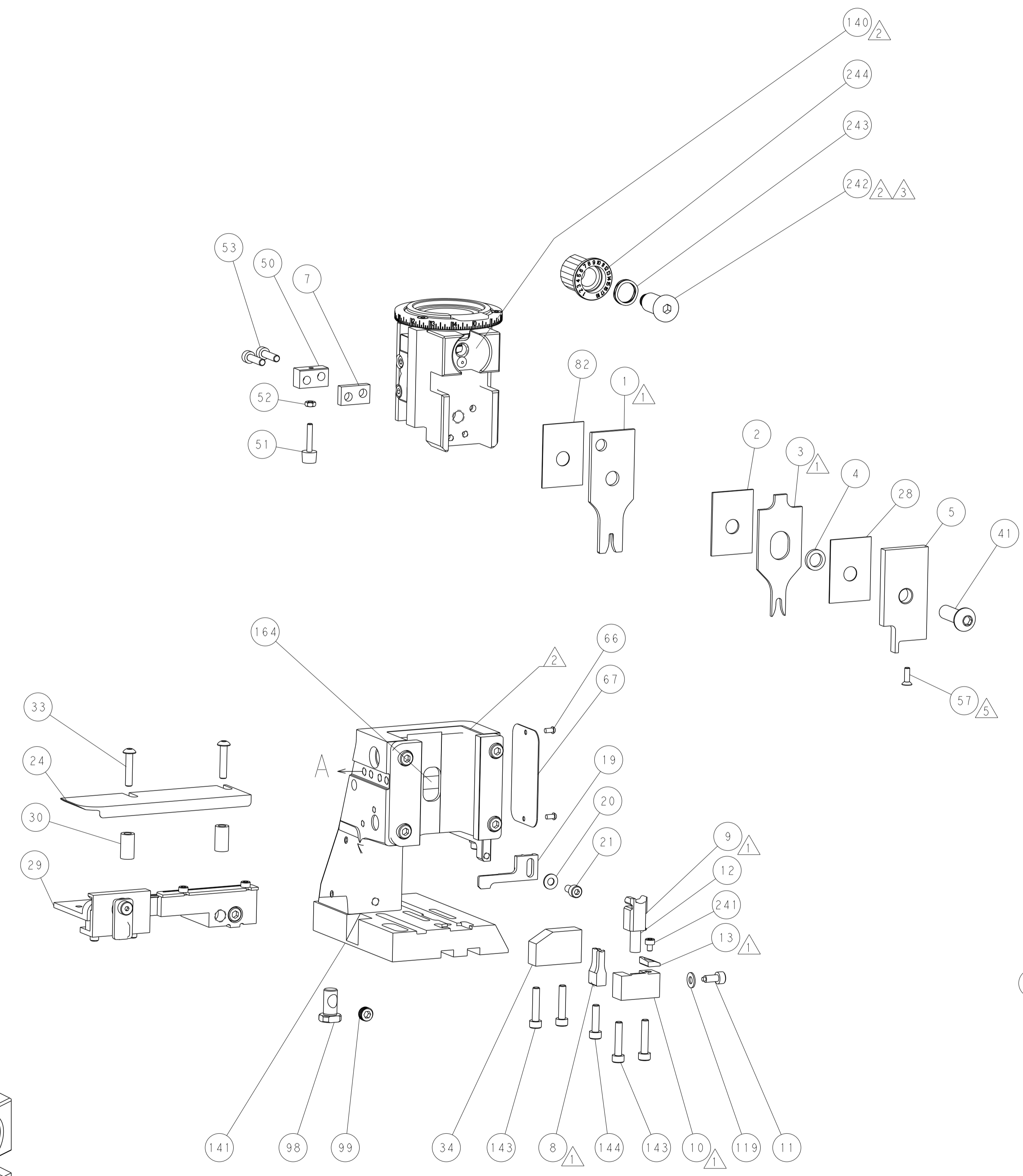
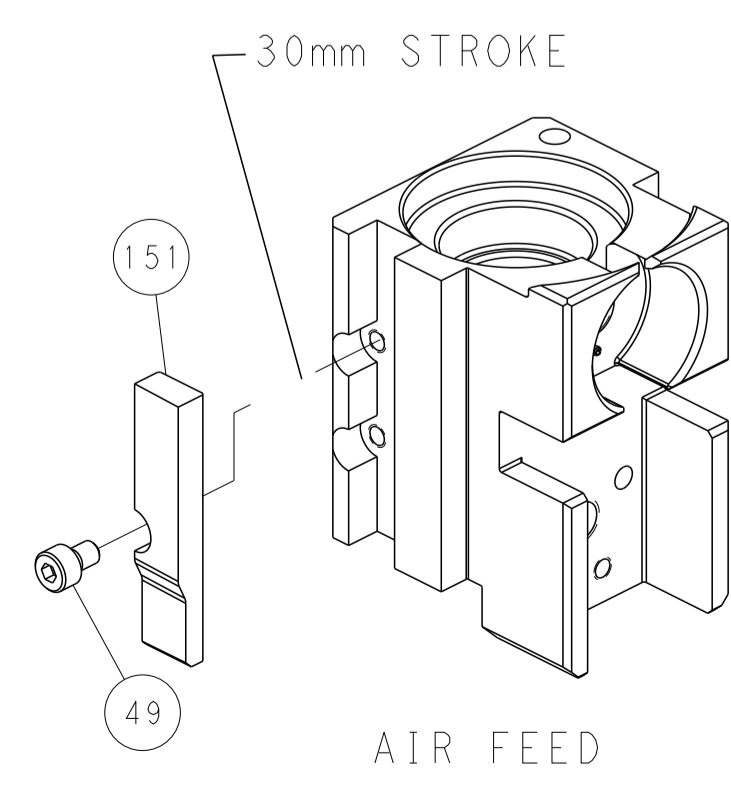
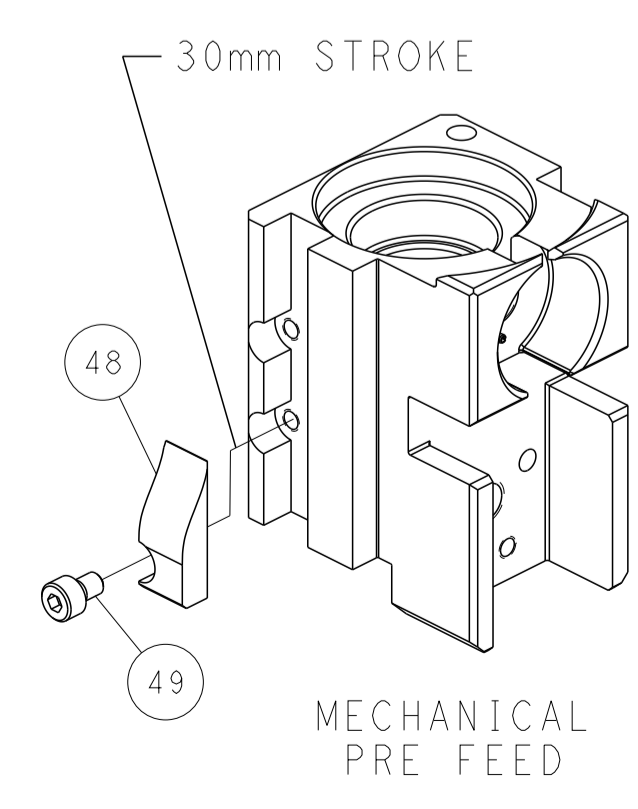
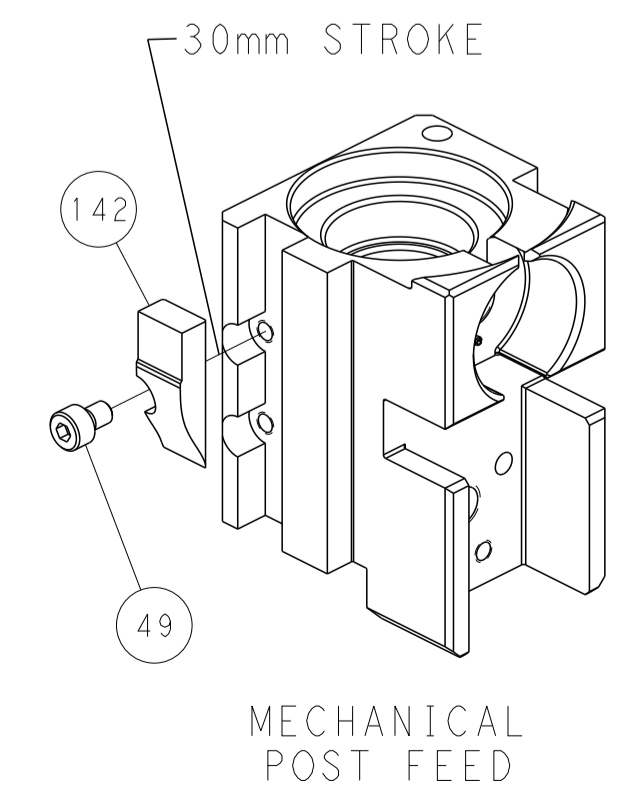

SHEAR DEPRESSOR DETAIL

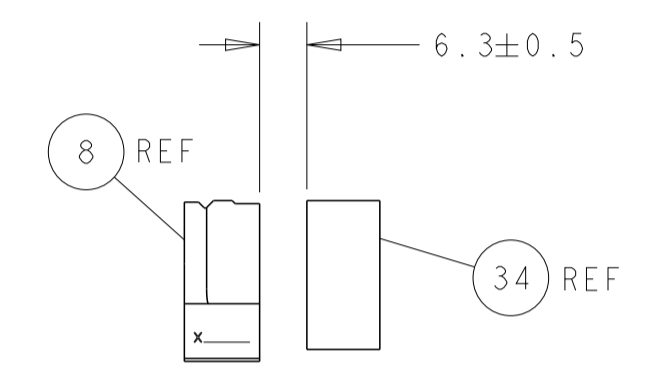

TERMINAL SUPPORT LOCATION

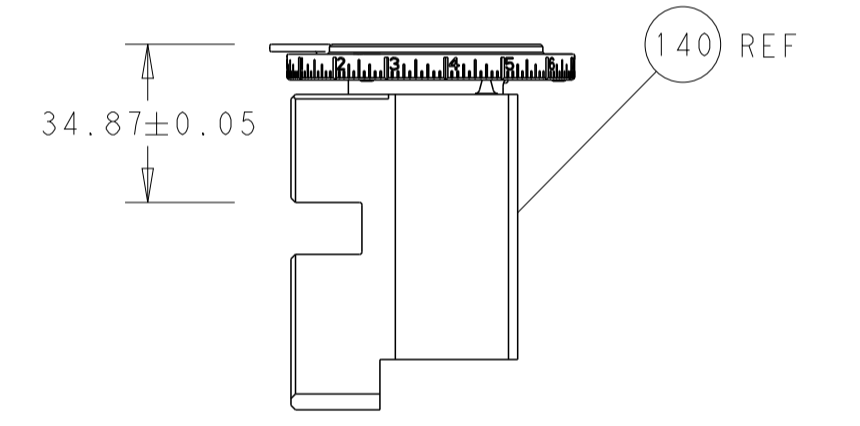

RAM SET-UP

ITEM 30 LOCATED AT  
FRONT HOLES

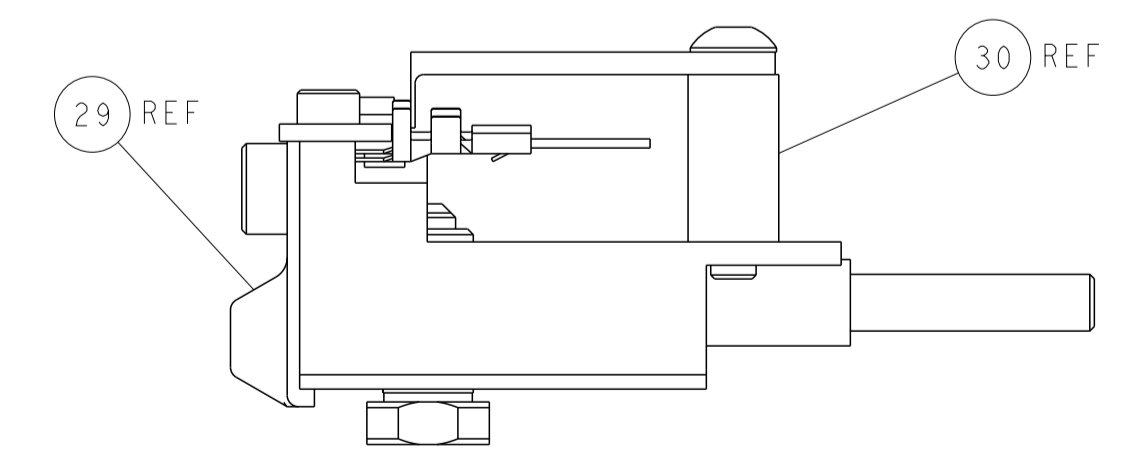

FEED TRACK POSITION  
GUIDE BY INSULATION BARREL

**PACIFIC VERSION**  
 Shown on sheets 3 of 4 & 4 of 4  
 (Atlantic version shown on sheets 1 of 4 & 2 of 4)

<small>THIS DRAWING IS UNPUBLISHED. RELEASED FOR PUBLICATION BY TYCO ELECTRONICS CORPORATION. ALL RIGHTS RESERVED.</small>		DWN: HOFFNER 11MAR2013 CHK: T. ELBIN 12MAR2013 APVD: T. ELBIN 12MAR2013	TE Connectivity Harrisburg, PA 17105-3608
DIMENSIONS: mm TOLERANCES UNLESS OTHERWISE SPECIFIED: 0 PLC ± 1 PLC ± 2 PLC ± 3 PLC ± 4 PLC ± ANGLES FINISH ±		NAME: Ocean Side Feed Applicator APPLICATION SPEC:	SIZE: A1 CAGE CODE: 00779 DRAWING NO: C=2151204 RESTRICTED TO:
MATERIAL:		WEIGHT:	SCALE: 1:2 SHEET: 4 of 4 REV: D