

ATLANTIC VERSION TERMINATOR INTERFACE ADAPTER	PART NUMBER	REVISION	DESCRIPTION	FEED TYPE	CONVERT TO	PART NUMBERS REQUIRED					
	2150307-1	B	FINE CRIMP HEIGHT ADJUST	MECHANICAL	PNEUMATIC FEED	2119950-1	2119792-2	-	2119641-1	-	2063440-1
	2150307-2	B	FINE CRIMP HEIGHT ADJUST	PNEUMATIC	SERVO LATCH PLATE	2119951-1	1901697-1	8-2150307-5	-	-	2168400-7 (QUANTITY 2)
					SMART APPLICATOR	2161326-1	-	8-2150307-4	-	-	-
					MECHANICAL FEED	2119949-1	2063961-1	5-18022-5	2119653-1	-	-
	2150307-5	B	FINE CRIMP HEIGHT ADJUST	SERVO LATCH PLATE	SERVO LATCH PLATE	2119951-1	1901697-1	8-2150307-5	-	-	2168400-7 (QUANTITY 2)
					SMART APPLICATOR	2161326-1	-	8-2150307-4	-	-	-
					MECHANICAL FEED	2119949-1	2063961-1	5-18022-5	2119653-1	-	-
	2150307-6	B	NON-CRIMP HEIGHT ADJUST	SERVO LATCH PLATE	PNEUMATIC FEED	2119950-1	2119792-2	-	2119641-1	-	2063440-1
					-	-	-	-	-	-	-
	2150307-7	B	FINE CRIMP HEIGHT ADJUST	NONE	-	-	-	-	-	-	-
	7-2150307-7	B	CRIMP TOOLING KIT	-	-	-	-	-	-	-	-

APPLICATOR DATA		
CRIMP	SIZE	TYPE
WIRE	.110 [2.79 mm]	F
INSUL	.180 [4.57 mm]	F
APPL INSTRUCTIONS 408-10390		

TERMINAL DATA: TE TERMINAL		TE CRIMP SPECIFICATION
TERMINAL NAME: RING, AMPLIVAR		
WIRE STRIP LENGTH		INSULATION DIAMETER RANGE
4.78-4.78 mm [.188-.188 IN]		Ø3.18-4.19 mm [1.25-.165 IN]
TERMINAL APPLICATION SPECIFICATION	114-2084	
TERMINALS APPLIED		
TE TERMINAL	TE TERMINAL	TE TERMINAL
60322-2		

WIRE SIZE	CRIMP HEIGHT mm [INCH]	CRIMP HEIGHT REFERENCE SETTING
16 MAG	1.47+/-0.05 [0.058+/-0.002]	8.0
18 MAG	1.35+/-0.05 [0.053+/-0.002]	8.8
20 MAG	1.27+/-0.05 [0.050+/-0.002]	9.4

- 1 RECOMMENDED SPARE PARTS
- 2 GREASE BEARING SURFACES LIGHTLY
- 3 LUBRICATE DAILY PER THE APPLICATOR INSTRUCTION SHEET SUPPLIED WITH THE APPLICATOR.
- 4 APPLICATOR SPECIFIC DATA TO BE ENTERED INTO BLANK MEMORY CHIP AT ASSEMBLY. SEE BELOW FOR PART NUMBER:  
 MECHANICAL FEED WITH "SMART APPLICATOR" CONVERSION: 8-2150307-4  
 PNEUMATIC FEED WITH "SMART APPLICATOR" CONVERSION: 8-2150307-4  
 SERVO FEED WITH "FINE CRIMP HEIGHT ADJUST": 8-2150307-5  
 SERVO FEED WITH "NON-CRIMP HEIGHT ADJUST": 8-2150307-6
- 5 ADJUSTMENT OF THE STRIPPER MAY BE REQUIRED WHEN MOVING THE APPLICATOR BETWEEN BENCH AND LEADMAKER APPLICATIONS.
- 6 APPLY PART NUMBER 1-23419-5 LOCTITE TO THREADS OF ITEMS 50 & 62. APPLY PART NUMBER 2-23419-6 LOCTITE TO THREADS OF ITEMS 242. FOR -6 ONLY APPLY PART NUMBER 1-23419-5 LOCTITE TO THREADS OF ITEM 37 & 50.
- 7 GREASE THREADS, GROOVE AND O-RING ON ITEMS 35 & 252.
- 8 MAGNET, ITEM 166 MUST BE ORIENTED CORRECTLY IN ORDER TO PROPERLY ACTUATE THE COUNTER.
- 9 CRIMP HEIGHT REFERENCE SETTING WAS THE SETTING USED WHEN THE APPLICATOR WAS QUALIFIED AT THE FACTORY. ADJUSTMENT MAY BE NECESSARY WHEN RUNNING APPLICATOR IN THE FIELD.
- 10 SPARE FEED CAM STORAGE LOCATION REFER TO INSTRUCTION SHEET FOR ADDITIONAL INFORMATION.
- 11 THE RECOMMENDED SET-UP FOR END FEED APPLICATORS IS POST-FEED WITH ITEM 2119653-1. THE APPLICATOR CAN BE CONFIGURED FOR PRE-FEED WITH ITEM 2119652-1 BUT MAY ENCOUNTER PROBLEMS WITH SOME APPLICATIONS. FEED ISSUES OR TERMINAL JAMMING MAY OCCUR IN THE PRE-FEED CONFIGURATION.
- 12 WHEN ASSEMBLING -6 NON-CRIMP HEIGHT ADJUST APPLICATOR USE SHIM PACK 2119957-2 TO ALIGN APPLICATOR'S MAXIMUM WIRE CRIMP HEIGHT AT NORMAL TERMINATOR SHUT HEIGHT

**\*WARNING**  
 ON INSTALLATION, SET WIRE DISC, ITEM 40 TO LARGEST WIRE SIZE SETTING. USE OF SETTINGS BELOW MINIMUM REQUIRED CRIMP HEIGHT SETTING WILL CAUSE DAMAGE TO CRIMP TOOLING.

-	-	1	-	-	-	2119957-2	APPLICATOR SHIM PACK	260
-	1	-	1	1	1	8-21084-0	O-RING, .676 ID, .070 DIA. MAT.	252
-	-	-	-	1	-	2119640-1	PUSH ROD, AIR FEED	250
-	-	-	-	1	-	2079988-1	BUSHING, LCH5-12, MISUMI	249
-	-	-	-	1	-	2119641-1	FEED CAM, AIR FEED	248
-	1	-	1	1	1	2119798-1	DETENT PIN	247
-77	-7	-6	-5	-2	-1	PART NO	DESCRIPTION	ITEM NO

**ATLANTIC VERSION**  
 Shown on sheets 1 of 4 & 2 of 4  
 (Pacific version shown on sheets 3 of 4 & 4 of 4)

SET UP GAUGE	LOC	DIST	REVISIONS					
2119599-2	A	66	#	LTN	DESCRIPTION	DATE	OWN	APVD
			1		DEVELOPMENT	09JAN2013	KH	SX
			2		CHANGE PARTS	27APR2013	YY	UG
			A		RELEASED	03JUL2013	YY	UG
			B		ECR-17-018798	15JAN2018	MZ	KZ

-	1	-	1	1	1	1-22279-3	SPRING, COMPRESSION	246
-	-	1	-	-	-	2119759-1	RAM, AMP STYLE, END FEED, NON-ADJUST	245
-	1	1	1	1	1	2119082-9	CAM, SNAIL, INSULATION ADJUSTMENT	244
-	1	1	1	1	1	2079764-1	WASHER, WAVE SPRING, CREST-TO-CREST	243
-	1	1	1	1	1	2119083-1	RETAINER, INSULATION DIAL	242
-	-	2	2	-	-	2168400-7	SHCS, LOW HEAD, RoHS, M5 X 10	240
-	-	-	-	-	1	2119580-1	MECHANICAL FEED ASSEMBLY	239
-	-	-	-	1	-	2063440-1	AIR FEED MODULE	238
-	-	1	1	-	-	2119740-2	TAG, IDENTIFICATION	213
-	-	REFREF	-	-	-	1901697-1	FEED FINGER ASSEMBLY, EF	183
-	1	1	1	1	1	6-993111-6	PIN, SLOTTED SPRING 3.0 X 14.0	177
-	1	1	1	1	1	8-22280-7	SPRING, COMPRESSION	176
-	1	1	1	1	1	1752353-2	GUIDE PIN, HOLDDOWN	175
-	1	1	1	1	1	1901680-2	GUIDE PIN, HOLDDOWN	174
-	-	-	-	2	-	21045-3	RING, RETAIN, EXTERN, 3/16 CRESCENT	172
-	-	-	-	1	1	994969-1	MAGNET, RARE EARTH HIGH ENERGY	166
-	REFREF	REFREF	REFREF	REFREF	REFREF	994970-2	COUNTER, MAGNETIC	164
-	-	-	-	1	-	240638-1	SPRING, FEED FINGER	163
-	-	-	-	1	-	3-23627-7	PIN, RETAIN, GRVD, 3/16 X .854	137
-	-	REFREF	-	-	-	SEE NOTE 4	MEMORY CHIP, PROGRAMMED	135
-	-	1	1	-	-	1633743-1	SERVO FEED LATCH ASM	133
-	1	1	1	1	1	455888-6	SPACER, CRIMPER	82
-	1	1	1	1	1	2119956-2	DOCUMENTATION PACKAGE	71
-	2	2	2	2	2	2-18032-2	SCR, SET, FLT PNT, M3 X 10.0	70
-	1	-	-	1	1	2119740-1	TAG, IDENTIFICATION	67
-	2	2	2	2	2	2168078-1	SCREW, DRIVE, RH, RoHS, 2 x .188	66
-	1	1	1	1	1	1-1901681-8	HOLDDOWN, TERMINAL	65
-	1	-	1	1	1	2119793-1	LIMITER, ADJUSTMENT BOLT	63
-	3	-	3	3	3	992763-5	SCR, SET, SOC, CONE PNT, M3 X 4.0	62
-	1	1	1	1	1	2079383-4	SCR, BHSC, RoHS (M4 X 8)	60
-	-	-	-	-	1	5-18022-5	SCR, HEX HD CAP, M4 X 6.0	59
-	-	-	-	-	1	2063961-1	FEED FINGER	58
-	4	4	4	4	4	2168400-4	SHCS, LOW HEAD, RoHS, M4 X 8	57
-	2	2	2	2	2	1-2168083-0	SCR, SKT HD CAP, RoHS, M4 X 10	56
-	2	2	2	2	2	5018030-2	NUT, HEX, REG, RoHS, M4	55
-	2	2	2	2	2	5018030-1	NUT, HEX, REG, RoHS, M3	54
-	2	2	2	2	2	986965-8	NUT, LOCK, HEX, TORQUE (M4)	53
-	1	1	1	1	1	1-5018030-0	NUT, HEX, REG, RoHS, M3.5	52
-	-	-	-	1	-	2119792-2	PAWL, EF, AIR	51
-	1	1	1	1	1	4-1752354-1	STANDOFF, HOLD-DOWN	50
-	-	-	-	-	1	18023-9	SCR, SKT HD CAP M4 X 6.0	49
-	-	-	-	-	1	2119652-1	FEED CAM, PRE FEED	48
-	-	-	-	-	1	2119653-1	FEED CAM, POST FEED	47
-	1	1	1	1	1	2119655-5	APPLICATOR BASIC ASSEMBLY, EF	46
-	1	-	1	1	1	2119369-1	RAM, AMP STYLE, END FEED	44
-	1	1	1	1	1	2079383-7	SCR, BHSC, RoHS (M8 X 25)	41
-	1	-	1	1	1	2119645-1	DISC, NUMBERED FA WIRE ADJUSTMENT	40
-	1	-	1	1	1	2119957-1	APPLICATOR SHIM PACK	39
-	1	1	1	1	1	1-2119644-2	RAM WASHER, PRECISION	38
-	1	1	1	1	1	2119085-1	FA HEAD, ATLANTIC STYLE	37
-	1	-	1	1	1	2119092-1	BOLT, ADJUSTMENT	35
-	8	8	8	8	8	1-18028-2	WASHER, FLAT, REG M4	33
-	2	2	2	2	2	2168083-9	SCR, SKT HD CAP, RoHS, M4 X 20	31
-	2	2	2	2	2	1-2168083-0	SCR, SKT HD CAP, RoHS, M4 X 10	29
-	1	1	1	1	1	240639-4	STRIPPER (MACHINING)	27
-	2	2	2	2	2	1320906-1	STUD, THREADED	25
-	1	1	1	1	1	1752371-1	PLATE, STRIP GUIDE	24
-	2	2	2	2	2	2-22281-3	SPRING, COMPRESSION	22
-	1	1	1	1	1	1752373-4	DRAG	20
-	1	1	1	1	1	1901696-3	STRIP GUIDE, REAR	19
-	1	1	1	1	1	1901695-3	STRIP GUIDE, FRONT	18
-	4	4	4	4	4	1-2079383-1	SCR, BHSC, RoHS (M6 X 12)	17
-	1	1	1	1	1	240644-1	PLATE, REAR SHEAR	11
-	-	-	-	-	-	-	-	10
-	1	1	1	1	1	690482-5	PLATE, FRONT SHEAR	9
-	1	1	1	1	1	1803064-1	ANVIL, COMBINATION	8
-	1	1	1	1	1	2217206-7	BLADE, SLUG	7
-	-	-	-	-	-	-	-	6
-	1	1	1	1	1	4-240641-1	SPACER	5
-	1	1	1	1	1	3-238009-8	BLOCK, FL CRIMPER SPACER	4
-	1	1	1	1	1	7-1633961-2	CRIMPER, INSULATION F PREMIUM	3
-	1	1	1	1	1	455888-6	SPACER, CRIMPER	2
-	1	1	1	1	1	5-456408-1	CRIMPER, WIRE PREMIUM	1
-77	-7	-6	-5	-2	-1	PART NO	DESCRIPTION	ITEM NO

DIMENSIONS:		TOLERANCES UNLESS OTHERWISE SPECIFIED:		DRAWING NO	
mm	0 PLC ±	1 PLC ±	2 PLC ±	3 PLC ±	4 PLC ±
mm	0 PLC ±	1 PLC ±	2 PLC ±	3 PLC ±	4 PLC ±
mm	0 PLC ±	1 PLC ±	2 PLC ±	3 PLC ±	4 PLC ±
mm	0 PLC ±	1 PLC ±	2 PLC ±	3 PLC ±	4 PLC ±
mm	0 PLC ±	1 PLC ±	2 PLC ±	3 PLC ±	4 PLC ±
MATERIAL	FINISH	WEIGHT	SCALE	SHEET	REV
			1:1	1 OF 4	B

LOC		DIST		REVISIONS			
A	66	P	LTM	DESCRIPTION	DATE	OWN	APVD
				SEE SHEET 1			

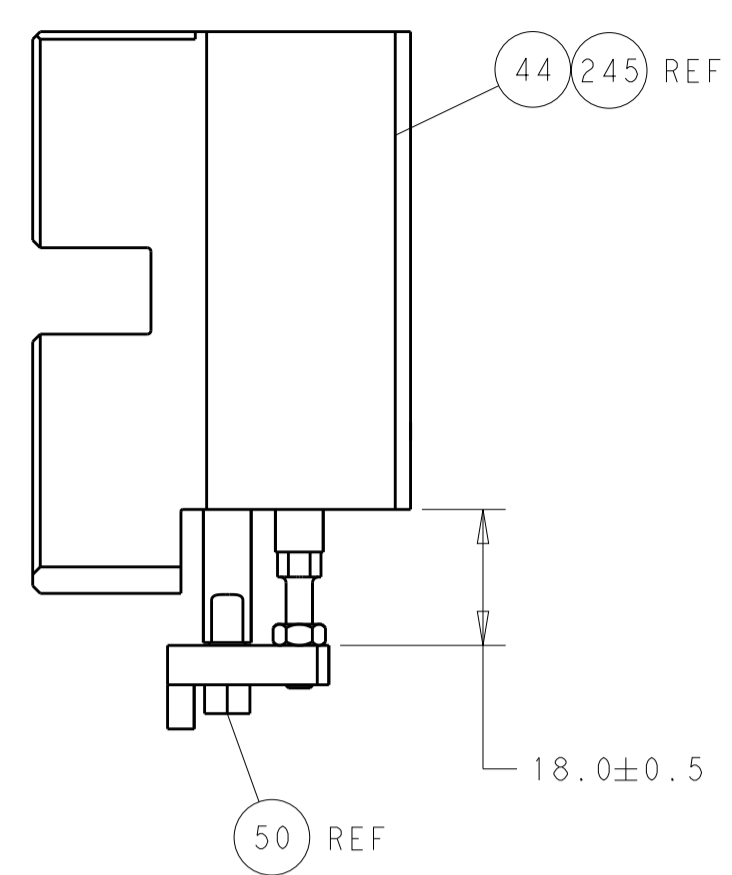

HOLDDOWN SET-UP

FEED TYPE  
MECHANICAL

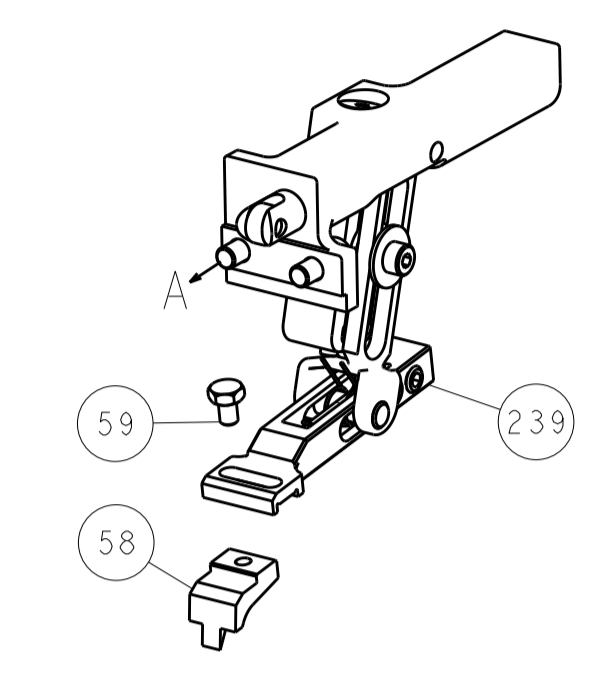

PNEUMATIC

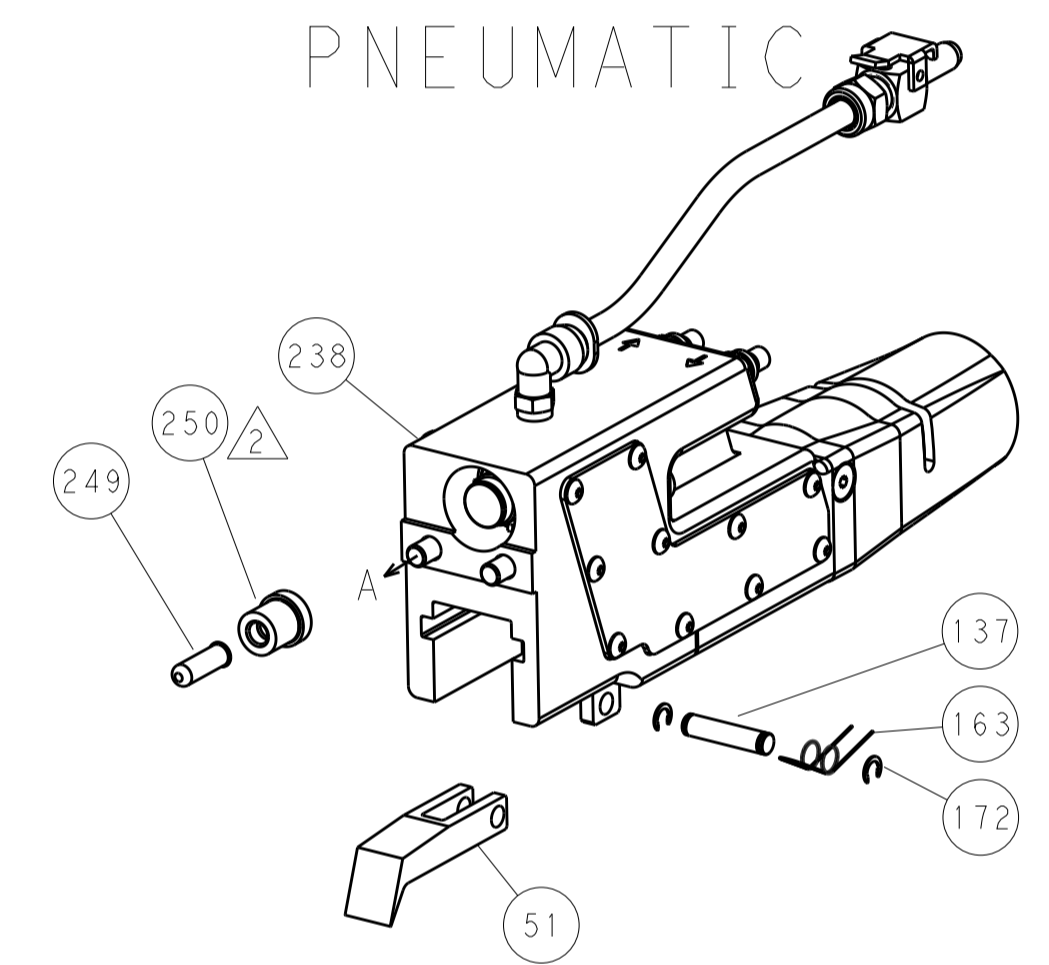

SERVO  
LATCH PLATE

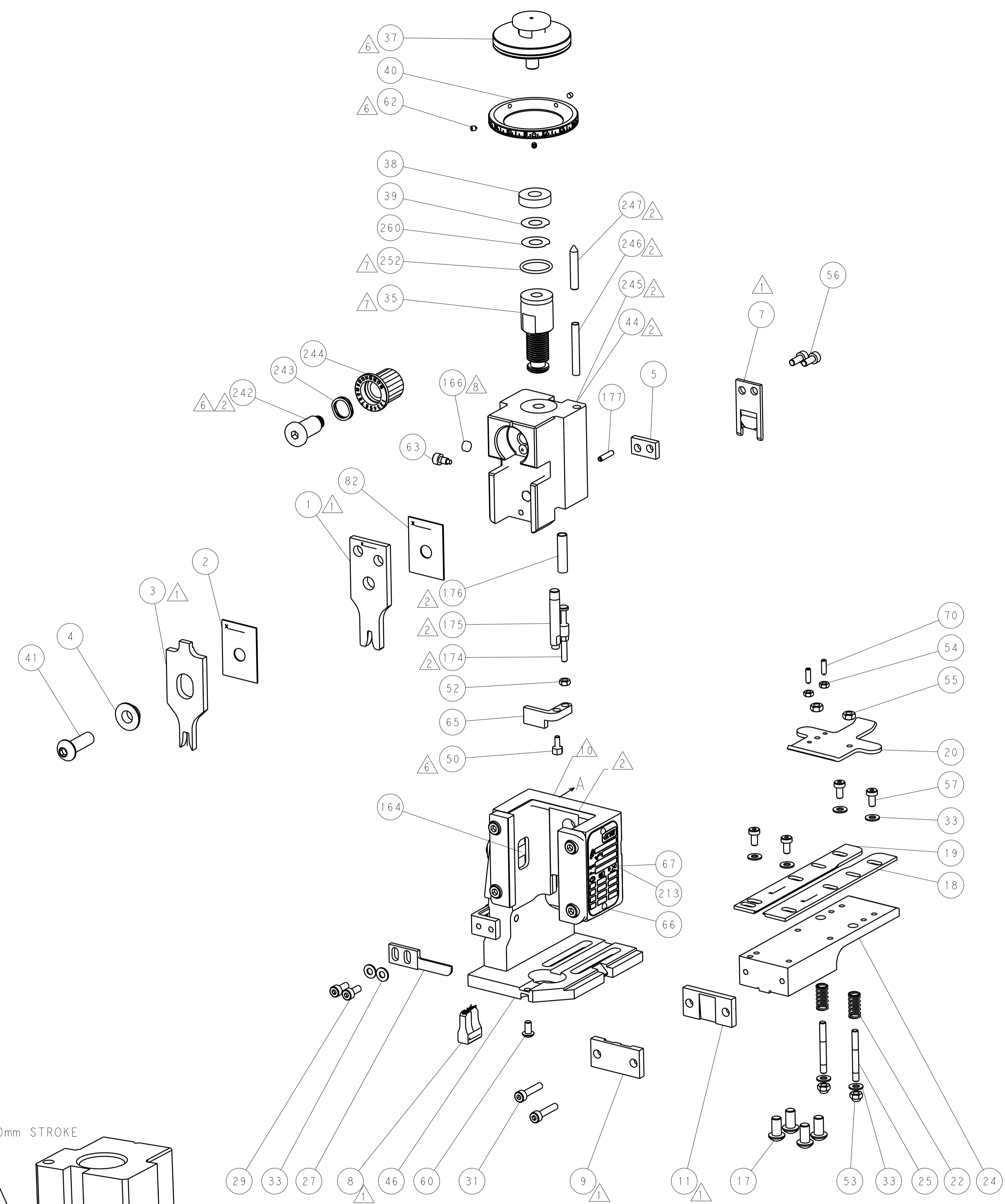
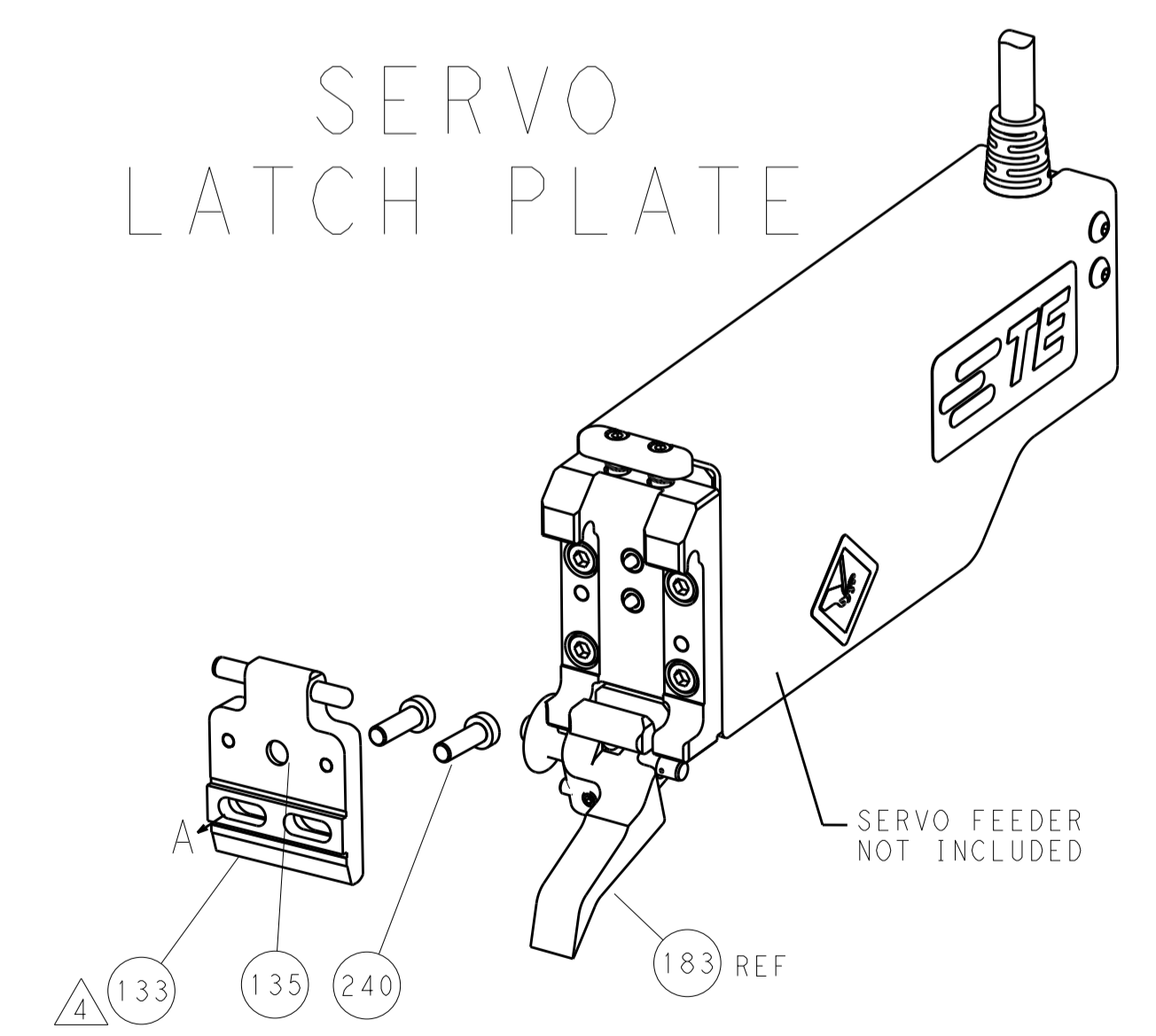

CAM POSITIONS



ATLANTIC VERSION  
 Shown on sheets 1 of 4 & 2 of 4  
 (Pacific version shown on sheets 3 of 4 & 4 of 4)

DIMENSIONS:		TOLERANCES UNLESS OTHERWISE SPECIFIED:		DWN K. HUANG 09JAN2013		TE Connectivity Harrisburg, PA 17105-3608	
mm	0 PLC	±		CHK S. XI 09JAN2013	NAME	Ocean End Feed Applicator	
	1 PLC	±		APVD S. XI 09JAN2013	PRODUCT SPEC	SIZE	CAGE CODE DRAWING NO
	2 PLC	±			APPLICATION SPEC	RESTRICTED TO	
	3 PLC	±				SCALE	1:1
	4 PLC	±				SHEET	2 OF 4
	ANGLES	±				REV	B
MATERIAL	FINISH			WEIGHT		Customer Accessible Production Drawing	
						A1 00779 ©=2150307	

PACIFIC VERSION TERMINATOR INTERFACE ADAPTER	PART NUMBER	REVISION	DESCRIPTION	FEED TYPE	APPLICATOR STYLE CONVERSION CHART						
					CONVERT TO	PART NUMBERS REQUIRED					
	2-2150307-1	B	FINE CRIMP HEIGHT ADJUST	MECHANICAL	PNEUMATIC FEED	2119950-1	2119792-2	-	2119641-2	-	2063440-1
					SERVO LATCH PLATE	2119951-1	1901697-1	8-2150307-5	-	-	2168400-7 (QUANTITY 2)
					SMART APPLICATOR	2161326-1	-	8-2150307-4	-	-	-
	2-2150307-2	B	FINE CRIMP HEIGHT ADJUST	PNEUMATIC	MECHANICAL FEED	2119949-1	2063961-1	5-18022-5	2119653-2	-	-
					SERVO LATCH PLATE	2119951-1	1901697-1	8-2150307-5	-	-	2168400-7 (QUANTITY 2)
					SMART APPLICATOR	2161326-1	-	8-2150307-4	-	-	-
	2-2150307-5	B	FINE CRIMP HEIGHT ADJUST	SERVO LATCH PLATE	MECHANICAL FEED	2119949-1	2063961-1	5-18022-5	2119653-2	-	-
					PNEUMATIC FEED	2119950-1	2119792-2	-	2119641-2	-	2063440-1
	2-2150307-7	B	FINE CRIMP HEIGHT ADJUST	NONE	-	-	-	-	-	-	-
	7-2150307-7	B	CRIMP TOOLING KIT	-	-	-	-	-	-	-	-

APPLICATOR DATA		
CRIMP	SIZE	TYPE
WIRE	.110 [2.79 mm]	F
INSUL	.180 [4.57 mm]	F
APPL INSTRUCTIONS 408-10390		

TERMINAL DATA: TE TERMINAL		TE CRIMP SPECIFICATION
TERMINAL NAME: RING, AMPLIVAR		
WIRE STRIP LENGTH 4.78-4.78 mm [1.88-.188 IN]		INSULATION DIAMETER RANGE 3.18-4.19 mm [1.25-.165 IN]
TERMINAL APPLICATION SPECIFICATION 114-2084		-
TERMINALS APPLIED		
TE TERMINAL	TE TERMINAL	TE TERMINAL
60322-2		

WIRE SIZE	CRIMP HEIGHT mm [INCH]	CRIMP HEIGHT REFERENCE SETTING
16 MAG	1.47 +/- 0.05 [0.058 +/- .002]	8.0
18 MAG	1.35 +/- 0.05 [0.053 +/- .002]	8.8
20 MAG	1.27 +/- 0.05 [0.050 +/- .002]	9.4

- RECOMMENDED SPARE PARTS
- GREASE BEARING SURFACES LIGHTLY
- 3. LUBRICATE DAILY PER THE APPLICATOR INSTRUCTION SHEET SUPPLIED WITH THE APPLICATOR.
- APPLICATOR SPECIFIC DATA TO BE ENTERED INTO BLANK MEMORY CHIP AT ASSEMBLY. SEE BELOW FOR PART NUMBER:  
 MECHANICAL FEED WITH "SMART APPLICATOR" CONVERSION: 8-2150307-4  
 PNEUMATIC FEED WITH "SMART APPLICATOR" CONVERSION: 8-2150307-4  
 SERVO FEED WITH "FINE CRIMP HEIGHT ADJUST": 8-2150307-5
- 5. ADJUSTMENT OF THE STRIPPER MAY BE REQUIRED WHEN MOVING THE APPLICATOR BETWEEN BENCH AND LEADMAKER APPLICATIONS.
- APPLY PART NUMBER 1-23419-5 LOCTITE TO THREADS OF ITEMS 50 & 62. APPLY PART NUMBER 2-23419-6 LOCTITE TO THREADS OF ITEMS 242.
- GREASE THREADS, GROOVE AND O-RING ON ITEMS 139 & 153.
- MAGNET, ITEM 166 MUST BE ORIENTED CORRECTLY IN ORDER TO PROPERLY ACTUATE THE COUNTER.
- CRIMP HEIGHT REFERENCE SETTING WAS THE SETTING USED WHEN THE APPLICATOR WAS QUALIFIED AT THE FACTORY. ADJUSTMENT MAY BE NECESSARY WHEN RUNNING APPLICATOR IN THE FIELD.
- SPARE FEED CAM STORAGE LOCATION REFER TO INSTRUCTION SHEET FOR ADDITIONAL INFORMATION.
- THE RECOMMENDED SET-UP FOR END FEED APPLICATORS IS POST-FEED WITH ITEM 2119653-1. THE APPLICATOR CAN BE CONFIGURED FOR PRE-FEED WITH ITEM 2119652-1 BUT MAY ENCOUNTER PROBLEMS WITH SOME APPLICATIONS. FEED ISSUES OR TERMINAL JAMMING MAY OCCUR IN THE PRE-FEED CONFIGURATION.

**\*WARNING**  
 ON INSTALLATION, SET WIRE DISC, ITEM 40 TO LARGEST WIRE SIZE SETTING. USE OF SETTINGS BELOW MINIMUM REQUIRED CRIMP HEIGHT SETTING WILL CAUSE DAMAGE TO CRIMP TOOLING.

-77-27-25-22-21	PART NO	DESCRIPTION	ITEM NO
- 1 1 1 1 1	2119782-1	FINE ADJUST HEAD ASM, PACIFIC STYLE	251
- - - 1 -	2119640-1	PUSH ROD, AIR FEED	250
- - - 1 -	2079988-1	BUSHING, LCH5-12, MISUMI	249
- 1 1 1 1 1	1-22279-3	SPRING, COMPRESSION	246

**PACIFIC VERSION**  
 Shown on sheets 3 of 4 & 4 of 4  
 (Atlantic version shown on sheets 1 of 4 & 2 of 4)

SET UP GAUGE	LOC	DIST	REVISIONS			
2119599-2	A	66	REV	DATE	BY	APPV
			-	SEE SHEET 1	-	-

- 1 1 1 1 1	2119082-9	CAM, SNAIL, INSULATION ADJUSTMENT	244
- 1 1 1 1 1	2079764-1	WASHER, WAVE SPRING, CREST-TO-CREST	243
- 1 1 1 1 1	2119083-1	RETAINER, INSULATION DIAL	242
- - 2 - -	2168400-7	SHCS, LOW HEAD, RoHS, M5 X 10	240
- - - 1 -	2119580-1	MECHANICAL FEED ASSEMBLY	239
- - - 1 -	2063440-1	AIR FEED MODULE	238
- - 1 - -	2119740-2	TAG, IDENTIFICATION	213
- 4 4 4 4 4	2079383-9	SCR, BHSC, RoHS (M6 X 20)	186
- - REF - -	1901697-1	FEED FINGER ASSEMBLY, EF	183
- 1 1 1 1 1	6-993111-6	PIN, SLOTTED SPRING 3.0 X 14.0	177
- 1 1 1 1 1	8-22280-7	SPRING, COMPRESSION	176
- 1 1 1 1 1	1752353-2	GUIDE PIN, HOLDDOWN	175
- 1 1 1 1 1	1901680-2	GUIDE PIN, HOLDDOWN	174
- - - 2 -	21045-3	RING, RETAIN, EXTERN, 3/16 CRESCENT	172
- 1 1 1 1 1	994969-1	MAGNET, RARE EARTH HIGH ENERGY	166
- REF REF REF REF REF	994970-2	COUNTER, MAGNETIC	164
- - - 1 -	240638-1	SPRING, FEED FINGER	163
- 1 1 1 1 1	8-21084-1	O-RING, .801 ID, .070 DIA. MAT.	153
- - - 1 -	2119641-2	FEED CAM, AIR FEED	152
- 1 1 1 1 1	2119798-2	DETENT PIN	145
- 1 1 1 1 1	2079383-8	SCR, BHSC, RoHS (M4 X 16)	144
- - - - 1	2119653-2	FEED CAM, POST FEED	142
- 1 1 1 1 1	2119655-6	APPLICATOR BASIC ASSEMBLY, EF	141
- 1 1 1 1 1	2119651-1	RAM, ASIAN STYLE, END FEED	140
- 1 1 1 1 1	2119092-2	BOLT, ADJUSTMENT	139
- - - 1 -	3-23627-7	PIN, RETAIN, GRVD, 3/16 X .854	137
- - REF - -	SEE NOTE 4	MEMORY CHIP, PROGRAMMED	135
- - 1 - -	1633743-1	SERVO FEED LATCH ASM	133
- 1 1 1 1 1	455888-6	SPACER, CRIMPER	82
- 1 1 1 1 1	2119956-2	DOCUMENTATION PACKAGE	71
- 2 2 2 2 2	2-18032-2	SCR, SET, FLT PNT, M3 X 10.0	70
- 1 - 1 1 1	2119740-1	TAG, IDENTIFICATION	67
- 2 2 2 2 2	2168078-1	SCREW, DRIVE, RH, RoHS, 2 x .188	66
- 1 1 1 1 1	1-1901681-8	HOLDDOWN, TERMINAL	65
- 1 1 1 1 1	2119793-1	LIMITER, ADJUSTMENT BOLT	63
- 3 3 3 3 3	992763-5	SCR, SET, SOC, CONE PNT, M3 X 4.0	62
- - - - 1	5-18022-5	SCR, HEX HD CAP, M4 X 6.0	59
- - - - 1	2063961-1	FEED FINGER	58
- 4 4 4 4 4	2168400-4	SHCS, LOW HEAD, RoHS, M4 X 8	57
- 2 2 2 2 2	1-2168083-0	SCR, SKT HD CAP, RoHS, M4 X 10	56
- 2 2 2 2 2	5018030-2	NUT, HEX, REG, RoHS, M4	55
- 2 2 2 2 2	5018030-1	NUT, HEX, REG, RoHS, M3	54
- 2 2 2 2 2	986965-8	NUT, LOCK, HEX, TORQUE (M4)	53
- 1 1 1 1 1	1-5018030-0	NUT, HEX, REG, RoHS, M3.5	52
- - - 1 -	2119792-2	PAWL, EF, AIR	51
- 1 1 1 1 1	4-1752354-1	STANDOFF, HOLD-DOWN	50
- - - 1 2	18023-9	SCR, SKT HD CAP M4 X 6.0	49
- - - - 1	2119652-1	FEED CAM, PRE FEED	48
- 1 1 1 1 1	2079383-7	SCR, BHSC, RoHS (M8 X 25)	41
- 1 1 1 1 1	2119645-1	DISC, NUMBERED FA WIRE ADJUSTMENT	40
- 1 1 1 1 1	2119957-1	APPLICATOR SHIM PACK	39
- 1 1 1 1 1	1-2119644-2	RAM WASHER, PRECISION	38
- 8 8 8 8 8	1-18028-2	WASHER, FLAT, REG M4	33
- 2 2 2 2 2	2168083-9	SCR, SKT HD CAP, RoHS, M4 X 20	31
- 2 2 2 2 2	1-2168083-0	SCR, SKT HD CAP, RoHS, M4 X 10	29
- 1 1 1 1 1	240639-4	STRIPPER (MACHINING)	27
- 2 2 2 2 2	1320906-1	STUD, THREADED	25
- 1 1 1 1 1	1752371-1	PLATE, STRIP GUIDE	24
- 2 2 2 2 2	2-22281-3	SPRING, COMPRESSION	22
- 1 1 1 1 1	1752373-4	DRAG	20
- 1 1 1 1 1	1901696-3	STRIP GUIDE, REAR	19
- 1 1 1 1 1	1901695-3	STRIP GUIDE, FRONT	18
- 1 1 1 1 1	240644-1	PLATE, REAR SHEAR	11
- - - - -	-	-	10
- 1 1 1 1 1	690482-5	PLATE, FRONT SHEAR	9
1 1 1 1 1 1	1803064-1	ANVIL, COMBINATION	8
- 1 1 1 1 1	2217206-7	BLADE, SLUG	7
- - - - -	-	-	6
- 1 1 1 1 1	4-240641-1	SPACER	5
- 1 1 1 1 1	3-238009-8	BLOCK, FL CRIMPER SPACER	4
1 1 1 1 1 1	7-1633961-2	CRIMPER, INSULATION F PREMIUM	3
- 1 1 1 1 1	455888-6	SPACER, CRIMPER	2
1 1 1 1 1 1	5-456408-1	CRIMPER, WIRE PREMIUM	1

DIMENSIONS:		TOLERANCES UNLESS OTHERWISE SPECIFIED:		DWN		CHK		APV		NAME	
mm	0 PLC ±	1 PLC ±	2 PLC ±	3 PLC ±	4 PLC ±	09JAN2013	09JAN2013	09JAN2013	09JAN2013	Ocean End Feed Applicator	
		FINISH		MATERIAL		WEIGHT		SCALE		SHEET 3 OF 4	
Customer Accessible Production Drawing		SCALE 1:1		SHEET 3 OF 4		REV B		DATE		BY	

LOC		DIST		REVISIONS			
A	66	P	LTM	DESCRIPTION	DATE	DMN	APVD
				SEE SHEET 1			

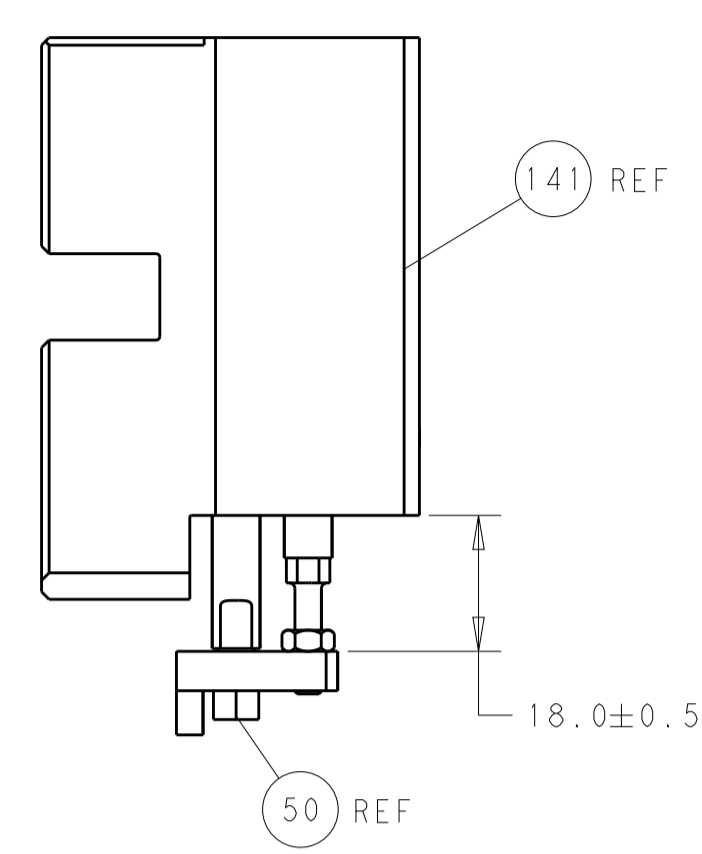

HOLDDOWN SET-UP

FEED TYPE  
MECHANICAL

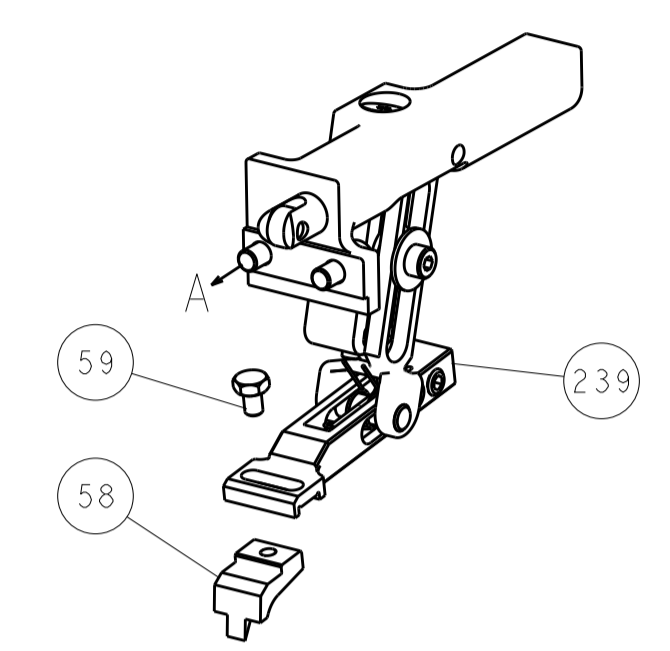

PNEUMATIC

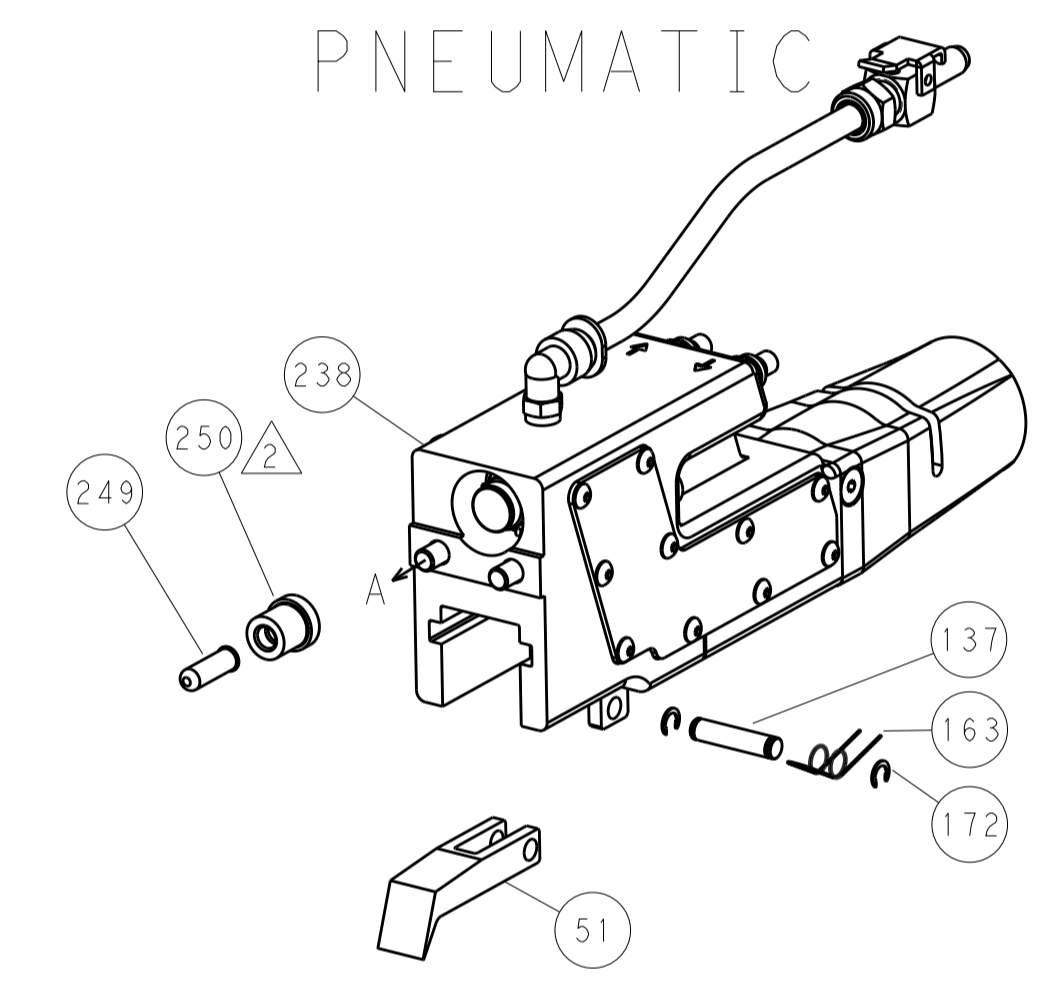

SERVO  
LATCH PLATE

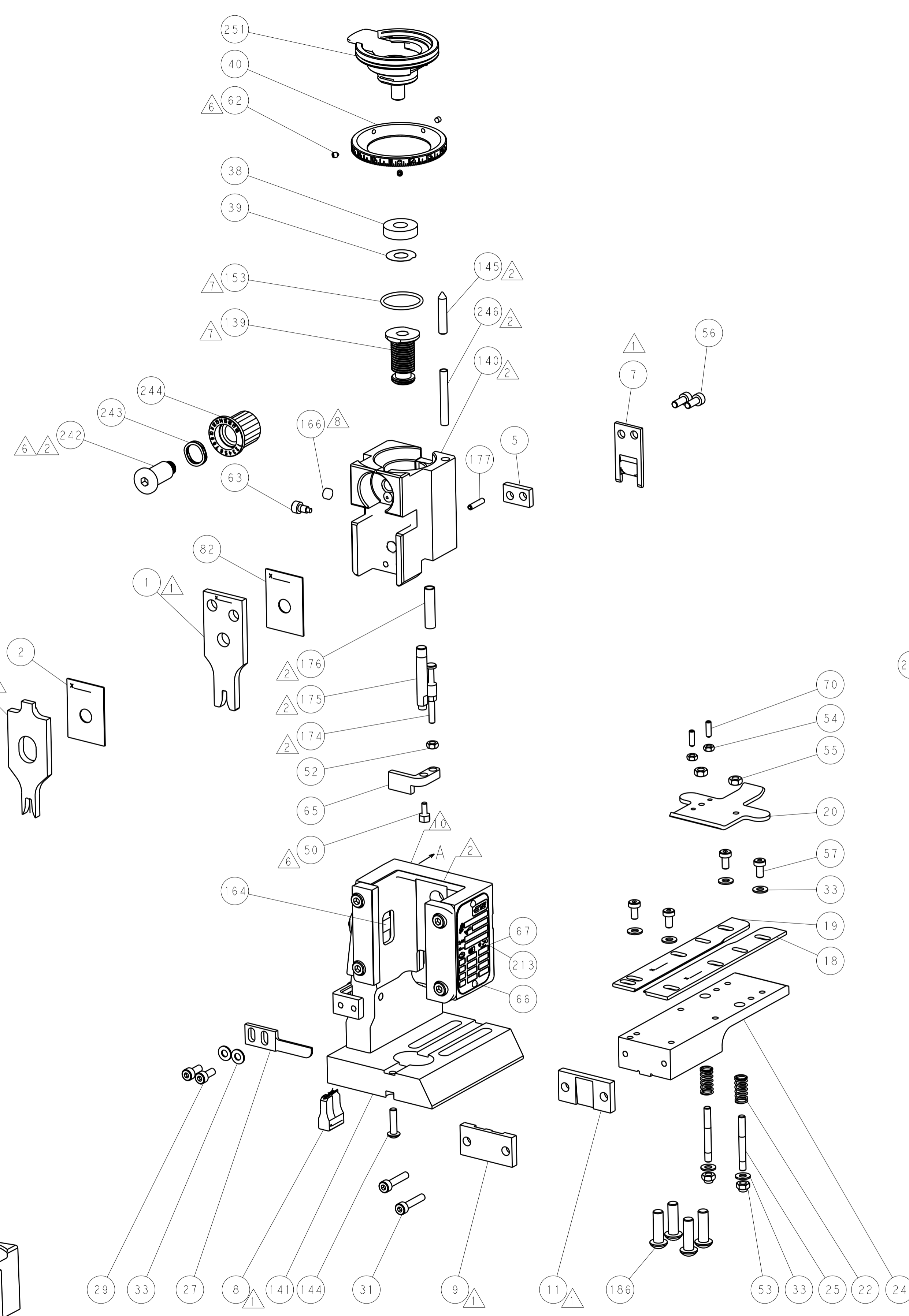
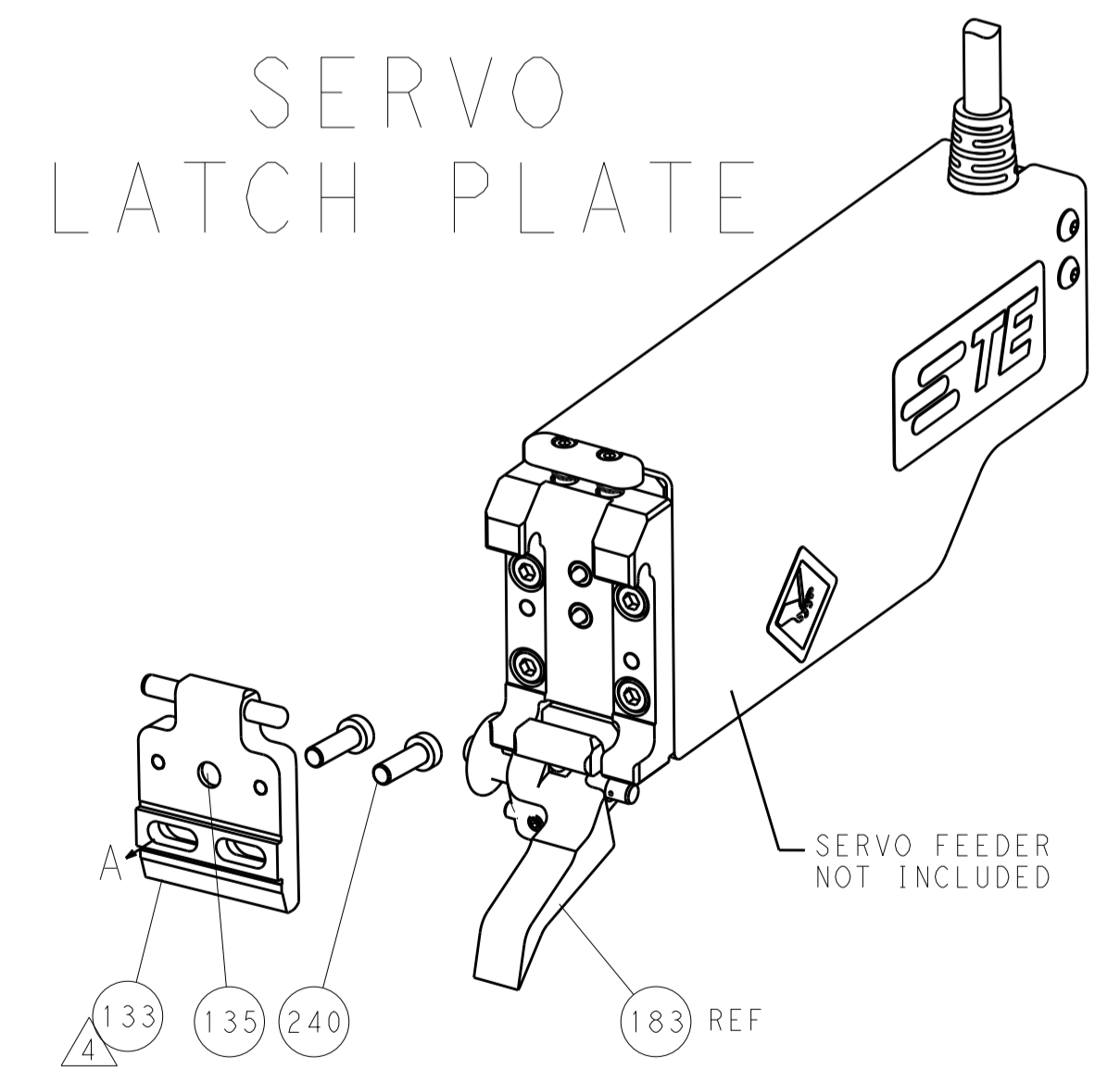

CAM POSITIONS

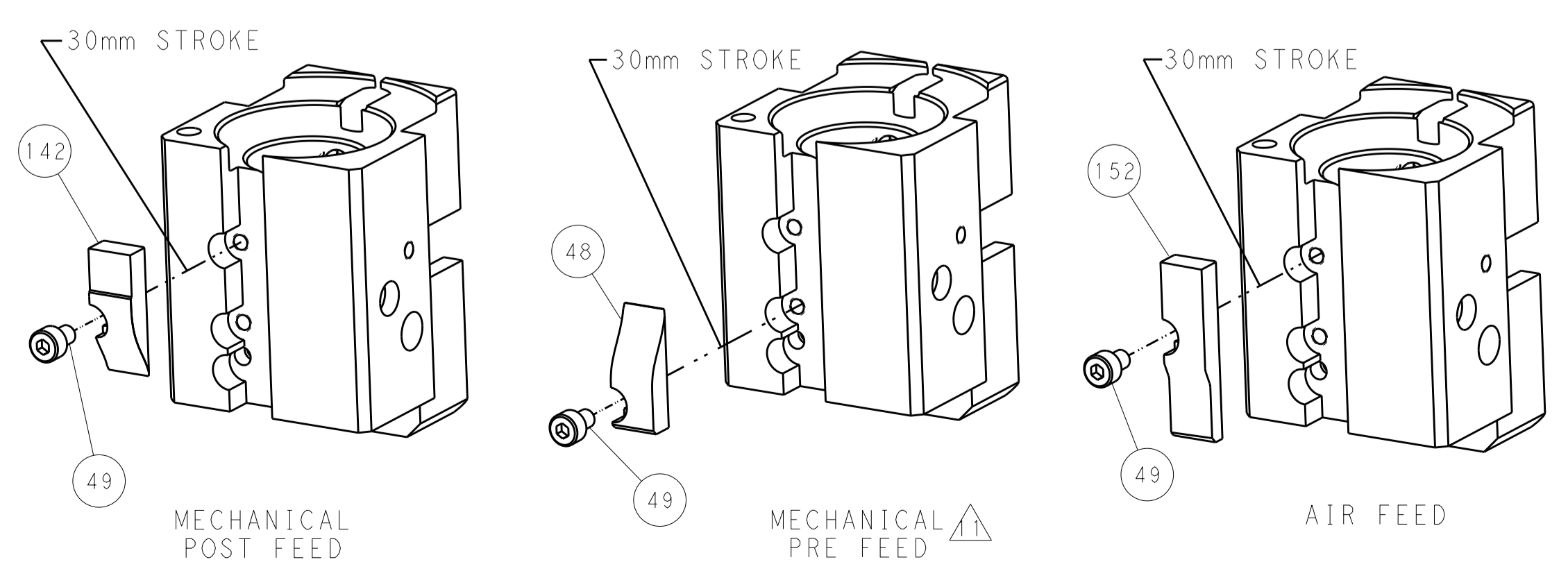

PACIFIC VERSION  
 Shown on sheets 3 of 4 & 4 of 4  
 (Atlantic version shown on sheets 1 of 4 & 2 of 4)

DIMENSIONS:		TOLERANCES UNLESS OTHERWISE SPECIFIED:		DWG: H. HUANG 09JAN2013		TE Connectivity	
mm	0 PLC ±	1 PLC ±	2 PLC ±	3 PLC ±	4 PLC ±	5 PLC ±	Harrisburg, PA 17105-3608
MATERIAL:	FINISH:	WEIGHT:	SCALE:	SIZE:	CAGE CODE:	DRAWING NO:	RESTRICTED TO:
			1:1	A1	00779	2150307	
Customer Accessible Production Drawing				SHEET 4 OF 4 REV B			