

PART NUMBER	REVISION	DESCRIPTION	FEED TYPE
2151272-1	F	FINE CRIMP HEIGHT ADJUST	MECHANICAL
2151272-2	F	FINE CRIMP HEIGHT ADJUST	PNEUMATIC
7-2151272-1	F	MECHANICAL AND CRIMP TOOLING KIT	MECHANICAL
7-2151272-2	F	PNEUMATIC AND CRIMP TOOLING KIT	PNEUMATIC
7-2151272-7	A	CRIMP TOOLING KIT	-

ATLANTIC VERSION TERMINATOR INTERFACE ADAPTER

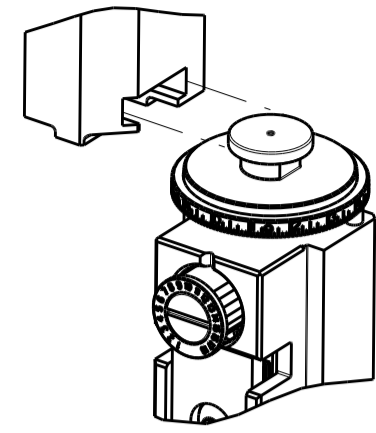

APPLICATOR DATA		
CRIMP	SIZE	TYPE
WIRE	2.79 mm [.110]	F
INSUL	6.60 mm [.260]	O

APPLICATOR INSTRUCTIONS  
408-35042

TERMINAL DATA: TE TERMINAL		TE CRIMP SPECIFICATION	
TERMINAL NAME: STANDARD POWER TIME CONTACT			
WIRE STRIP LENGTH		INSULATION DIAMETER RANGE	
4.90-5.50 mm [.193-.217 IN]		Ø	
TERMINAL APPLICATION SPECIFICATION	114-18037		

TERMINALS APPLIED				SEAL	INSULATION Ø RANGE
TE TERMINAL	TE TERMINAL	TE SEAL	TE SEAL		
927835-1	927835-2		963244-1		2.2-3.0
927835-7	1-927835-2		963245-1		3.4-3.7
1-927835-3	2-927835-1				
2-927835-2	8-927835-1				
964332-5	1-964332-1				
1-964332-2	1-964332-5				
968035-2	2-968035-4				

TERMINAL DATA: TE TERMINAL		TE CRIMP SPECIFICATION	
TERMINAL NAME: STANDARD POWER TIME CONTACT			
WIRE STRIP LENGTH		INSULATION DIAMETER RANGE	
4.90-5.50 mm [.193-.217 IN]		Ø	
TERMINAL APPLICATION SPECIFICATION	114-18037		

TERMINALS APPLIED					SEAL	INSULATION Ø RANGE
TE TERMINAL	TE TERMINAL	TE SEAL	TE SEAL			
964332-5	1-964332-1		963244-1			2.2-3.0
1-964332-2	1-964332-5		963245-1			3.4-3.7

WIRE SIZE	CRIMP HEIGHT mm [INCH]	CRIMP HEIGHT REFERENCE SETTING
2.50mm2	2.04 +/- 0.05 [.080 +/- .002]	4.1
2.00mm2	1.90 +/- 0.05 [.075 +/- .002]	5.9
1.50mm2	1.76 +/- 0.05 [.069 +/- .002]	7.0

WIRE SIZE	CRIMP HEIGHT W1_CRIMP_UNITS	CRIMP HEIGHT REFERENCE SETTING
2.50mm2	1.89 +/- 0.05 [.074 +/- .002]	5.6
1.50mm2	1.64 +/- 0.05 [.065 +/- .002]	8.0

- △ RECOMMENDED SPARE PARTS
- △ REFER TO SUPPLIED INSTRUCTION SHEET FOR CLEANING, LUBRICATION AND STORAGE OF APPLICATOR.
- △ APPLY PART NUMBER 2-23419-6 LOCTITE TO THREADS OF ITEM 242.
- △ CRIMP HEIGHT REFERENCE SETTING WAS THE SETTING USED WHEN THE APPLICATOR WAS QUALIFIED AT THE FACTORY. ADJUSTMENT MAY BE NECESSARY WHEN RUNNING APPLICATOR IN THE FIELD.
- △ APPLY TORO-SEAL IN ALLEN SOCKET TO FILL HOLE AFTER FLAT HD HAS BEEN ADJUSTED TO CORRECT HEIGHT AT QUALIFICATION. APPLY #1-23419-5 LOC-TITE TO THREADS.
- 6. UNLESS SPECIFIED OTHERWISE TORQUE VALUES SHALL BE USED PER DOCUMENT, 101-35000.
- △ CUT TO LENGTH AT ASSEMBLY

**\*WARNING**  
ON INSTALLATION, SET WIRE DISC TO CRIMP HEIGHT REFERENCE SETTING FOR LARGEST WIRE SIZE. CRIMP HEIGHT REFERENCE SETTINGS GREATER THAN THE VALUE SHOWN MAY CAUSE DAMAGE TO THE CRIMP TOOLING. REFER TO THE INSTRUCTION SHEET FOR PROPER SETUP AND ADJUSTMENTS.

REVISIONS				
P	LTN	DESCRIPTION	DATE	OWN APVD
E		ECR-17-009493	29JUN2017	RS LZ
G		ECR-19-012280	06AUG2019	MZ YY

-	1	-	1	-	2119640-1	PUSH ROD, AIR FEED	250
-	1	-	1	-	1803259-1	BUSHING, FLANGED	249
-	1	-	1	-	2119641-1	FEED CAM, AIR FEED	248
-	1	1	1	1	2119082-8	CAM, SNAIL, INSULATION ADJUSTMENT	244
-	1	1	1	1	2079764-1	WASHER, WAVE SPRING, CREST-TO-CREST	243
-	1	1	1	1	2119083-1	RETAINER, INSULATION DIAL	242
-	1	1	1	1	7-18023-7	SCR, SKT HD CAP M3 X 4.0	241
-	-	1	-	1	2119580-1	MECHANICAL FEED ASSEMBLY	239
-	1	-	1	-	2063440-1	AIR FEED MODULE	238
-	2	-	2	-	21045-3	RING, RETAIN, EXTERN, 3/16 CRESCENT	172
-	REF	REF	REF	REF	994970-2	COUNTER, MAGNETIC	164
-	1	-	1	-	240638-1	SPRING, FEED FINGER	163
-	1	-	1	-	3-23627-7	PIN, RETAIN, GRVD, 3/16 X .854	137
-	1	-	1	-	2119799-1	HOLDER, FEED FINGER, AF	136
-	1	1	1	1	2168083-6	SCR, SKT HD CAP, RoHS, M5 X 65	124
-	1	1	1	1	1-18028-2	WASHER, FLAT, REG M4	119
-	1	1	1	1	2844908-1	SCREW, LOCKING	99
-	1	1	1	1	2844907-1	POST, LOCKING	98
-	1	1	1	1	1-22281-8	SPRING, COMPRESSION	96
-	1	1	1	1	980371-4	SCR, SKT HD SHLDR 5.0 DIA X 6.0	83
-	1	1	1	1	455888-5	SPACER, CRIMPER	82
-	1	1	1	1	1803607-1	DOCUMENTATION PACKAGE	71
-	1	1	1	1	2119791-5	DEPRESSOR, WIRE	70
-	1	1	1	1	2119943-1	WASHER, SPACER	69
-	1	1	1	1	2119740-1	TAG, IDENTIFICATION	67
-	2	2	2	2	2168078-1	SCREW, DRIVE, RH, RoHS, 2 x .188	66
-	2	2	2	2	2168083-1	SCR, SKT HD CAP, RoHS, M3 X 8.0	65
-	2	2	2	2	2-18032-5	SCR, SET, FLT PNT, M5 X 20.0	61
-	1	1	1	1	2168083-2	SCR, SKT HD CAP, RoHS, M4 X 8.0	60
-	1	1	1	1	5-18022-5	SCR, HEX HD CAP, M4 X 6.0	59
-	1	1	1	1	985575-3	SCR, FLT SKT HD CAP M3 X 10.0	57
-	1	1	1	1	1338683-8	FEED PAWL	56
-	4	4	4	4	2168083-3	SCR, SKT HD CAP, RoHS, M4 X 12.0	54
-	2	2	2	2	2-2168083-5	SCR, SKT HD CAP, RoHS, M4 X 14	53
-	1	1	1	1	1803382-6	HOLD DOWN, SPRING LOADED	50
-	1	2	1	2	18023-9	SCR, SKT HD CAP M4 X 6.0	49
-	-	1	-	1	2119652-1	FEED CAM, PRE FEED	48
-	-	1	-	1	2119653-1	FEED CAM, POST FEED	47
-	1	1	1	1	1803583-3	APPLICATOR BASIC ASSEMBLY, SF	46
-	1	1	1	1	1803515-1	RAM ASSEMBLY, SF ATLANTIC	44
-	1	1	1	1	1803602-1	SCR, BHSC, RoHS (M8 X 25)	41
-	1	1	1	1	1-1752356-2	SUPPORT, TERMINAL	34
-	2	2	2	2	1-2079383-3	SCR, BHSC, RoHS (M4 X 25)	33
-	2	2	2	2	3-2844962-5	SPACER, CYLINDRICAL, STRIP GUIDE	30
-	1	1	1	1	1-2844938-7	PLATE, STRIP GUIDE	29
-	1	1	1	1	455888-4	SPACER, CRIMPER	28
-	2	2	2	2	22283-1	SPRING, COMPRESSION	27
-	1	1	1	1	356835-1	LEVER, DRAG RELEASE	26
-	1	1	1	1	240792-1	DRAG, TERMINAL	25
-	1	1	1	1	1320928-6	STRIP GUIDE	24
-	1	1	1	1	1-690438-0	FRONT STRIP GUIDE	23
-	1	1	1	1	2168083-2	SCR, SKT HD CAP, RoHS, M4 X 8.0	21
-	1	1	1	1	1-18028-2	WASHER, FLAT, REG M4	20
-	1	1	1	1	2119533-1	STRIPPER, SIDE FEED	19
-	1	1	1	1	2119806-1	INSERT, SHEAR	13
-	1	1	1	1	3-22280-3	SPRING, COMPRESSION	12
-	1	1	1	1	1-356885-3	STOP, SHEAR	11
-	1	1	1	1	2119805-2	SHEAR HOLDER, FRONT	10
-	1	1	1	1	318059-4	FLOATING SHEAR, FRONT	9
-	1	2	2	1	1333229-4	ANVIL, COMBINATION	8
-	1	1	1	1	240641-1	SPACER	7
-	-	-	-	-	-	-	7
-	-	-	-	-	-	-	6
-	1	1	1	1	2-2119781-2	DEPRESSOR, SHEAR	5
-	1	1	1	1	238011-8	BLOCK, CRIMPER SPACER	4
-	1	2	2	1	1803018-5	CRIMPER, INSULATION O	3
-	1	1	1	1	1-455888-4	SPACER, CRIMPER	2
-	1	2	2	1	456408-8	CRIMPER, WIRE PREMIUM	1
-	77	-72	-71	-2	-1	PART NO	ITEM NO

ATLANTIC VERSION  
Shown on sheets 1 of 4 & 2 of 4  
(Pacific version shown on sheets 3 of 4 & 4 of 4)

DIMENSIONS:		TOLERANCES UNLESS OTHERWISE SPECIFIED:		MATERIAL:		FINISH:		WEIGHT:		CUSTOMER ACCESSIBLE PRODUCTION DRAWING	
mm	0 PLC	±									
	1 PLC	±									
	2 PLC	±									
	3 PLC	±									
	4 PLC	±									
	ANGLES	±									

REVISIONS				
P.	LTN	DESCRIPTION	DATE	APVD
-	-	SEE SHEET 1	-	-

# FEED TYPE MECHANICAL

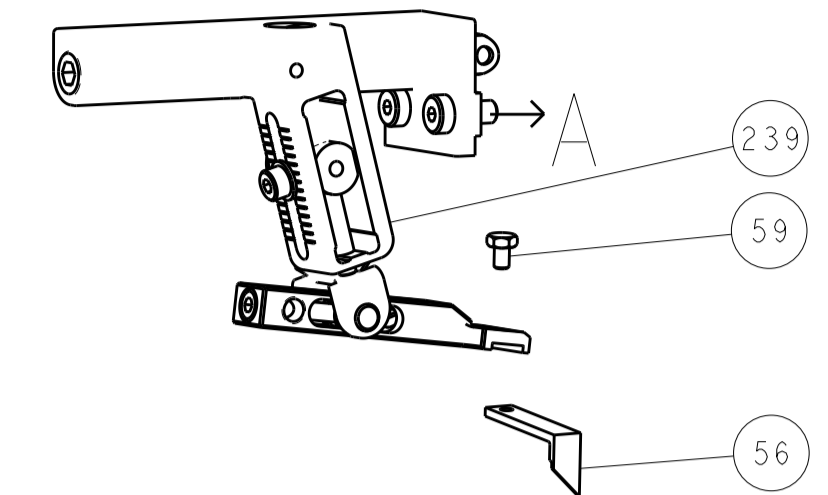

# PNEUMATIC

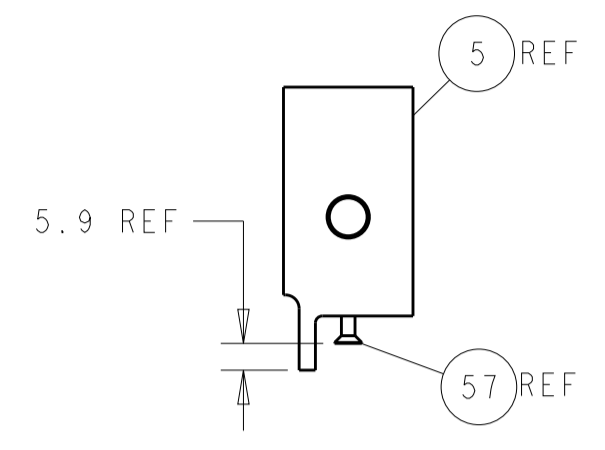
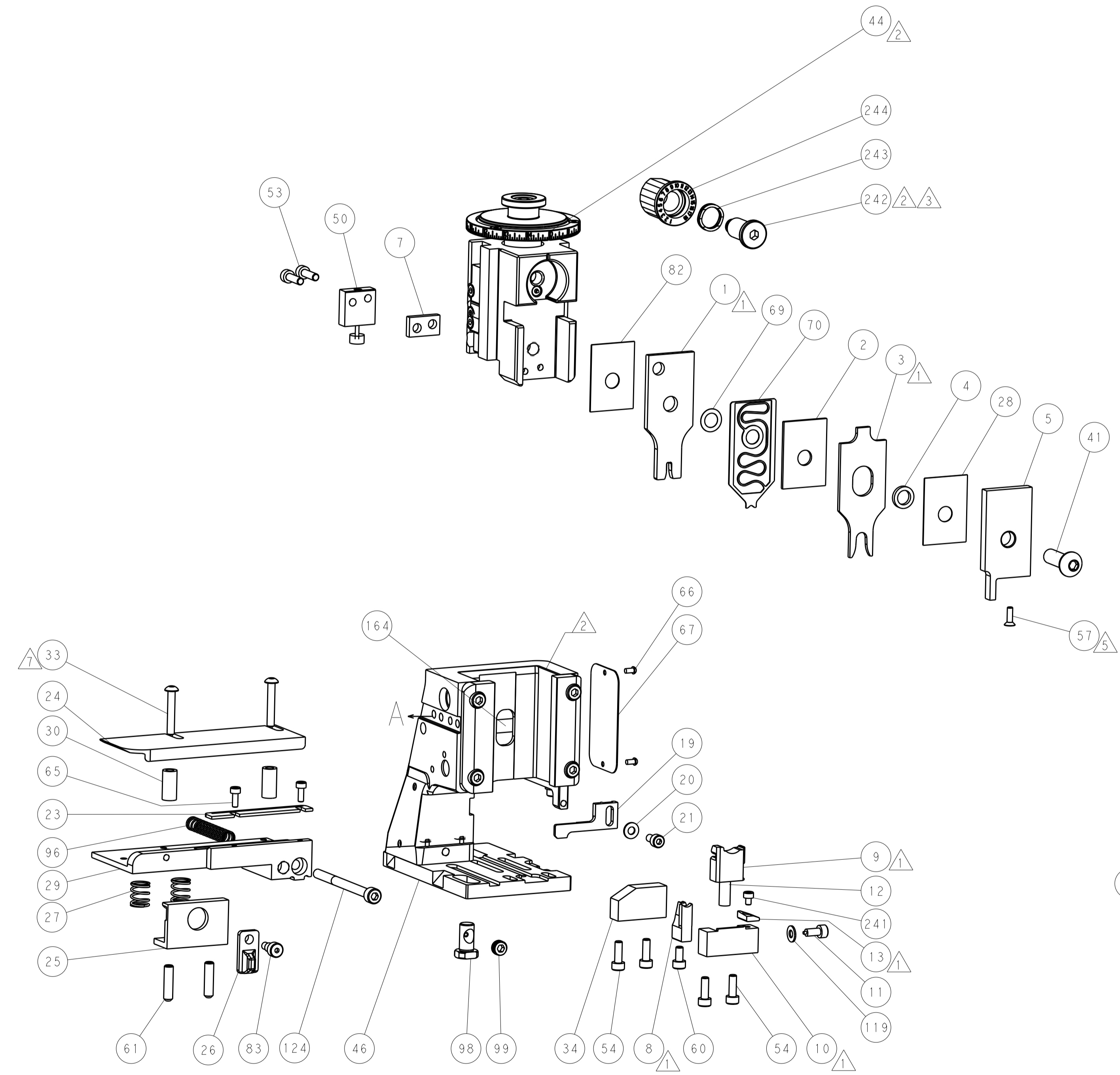
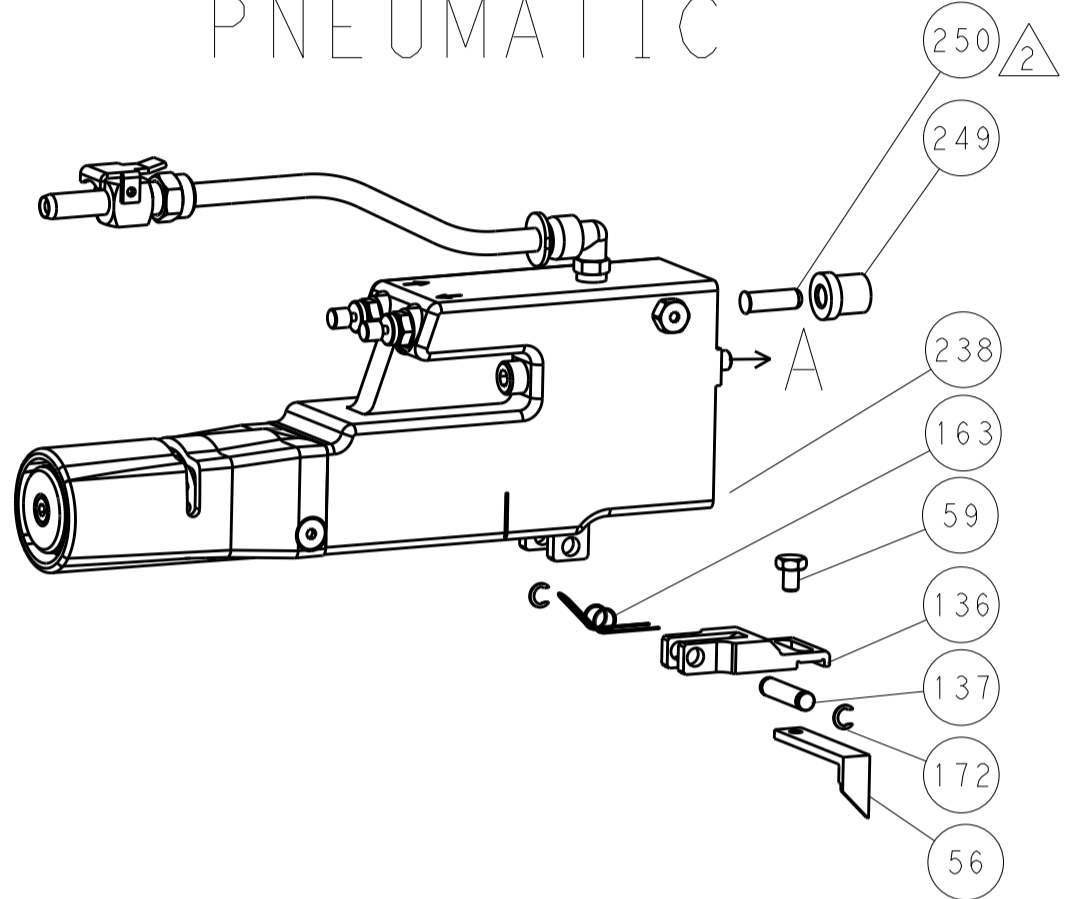

SHEAR DEPRESSOR DETAIL

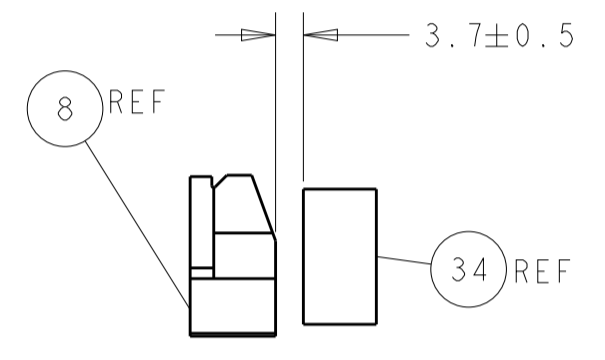

TERMINAL SUPPORT LOCATION

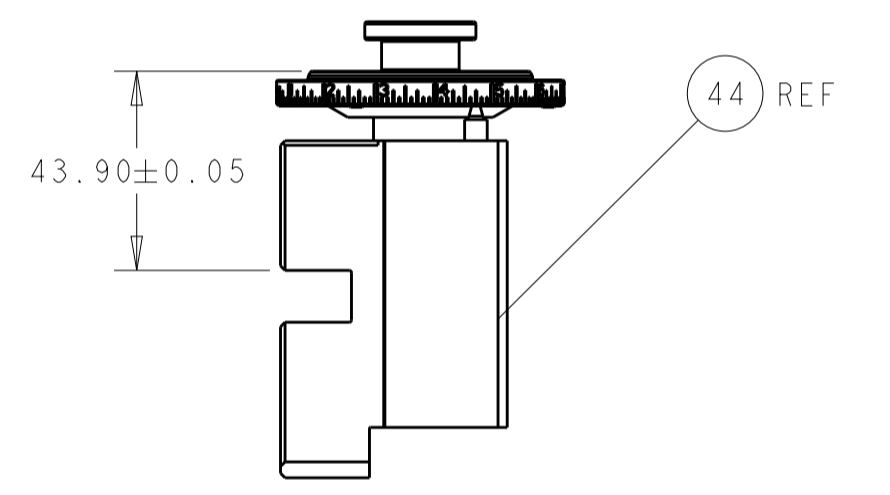

RAM SET-UP

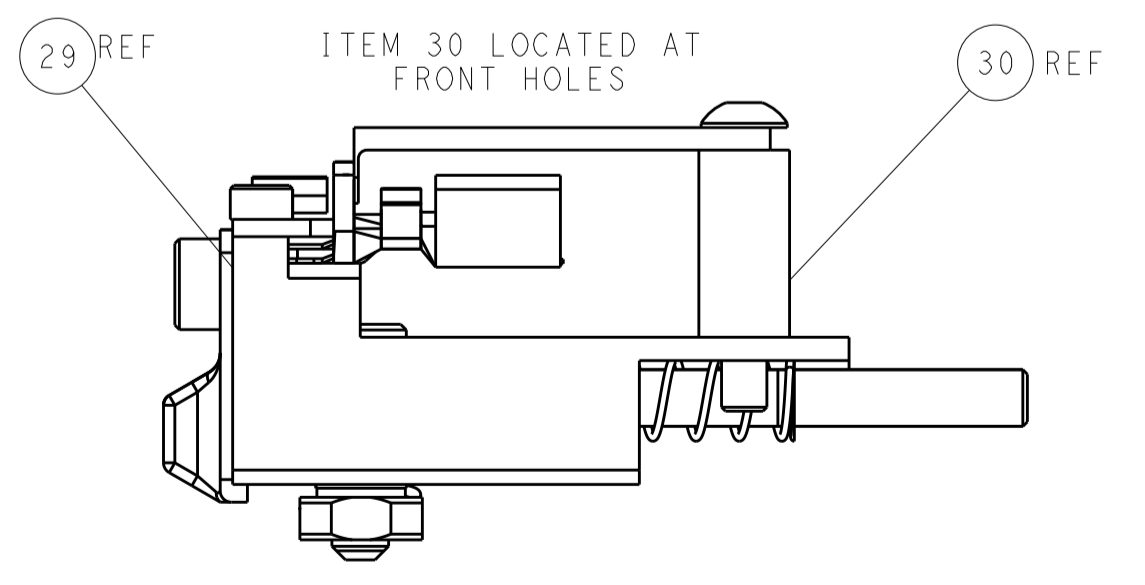

FEED TRACK POSITION GUIDE BY INSULATION BARREL

# CAM POSITIONS

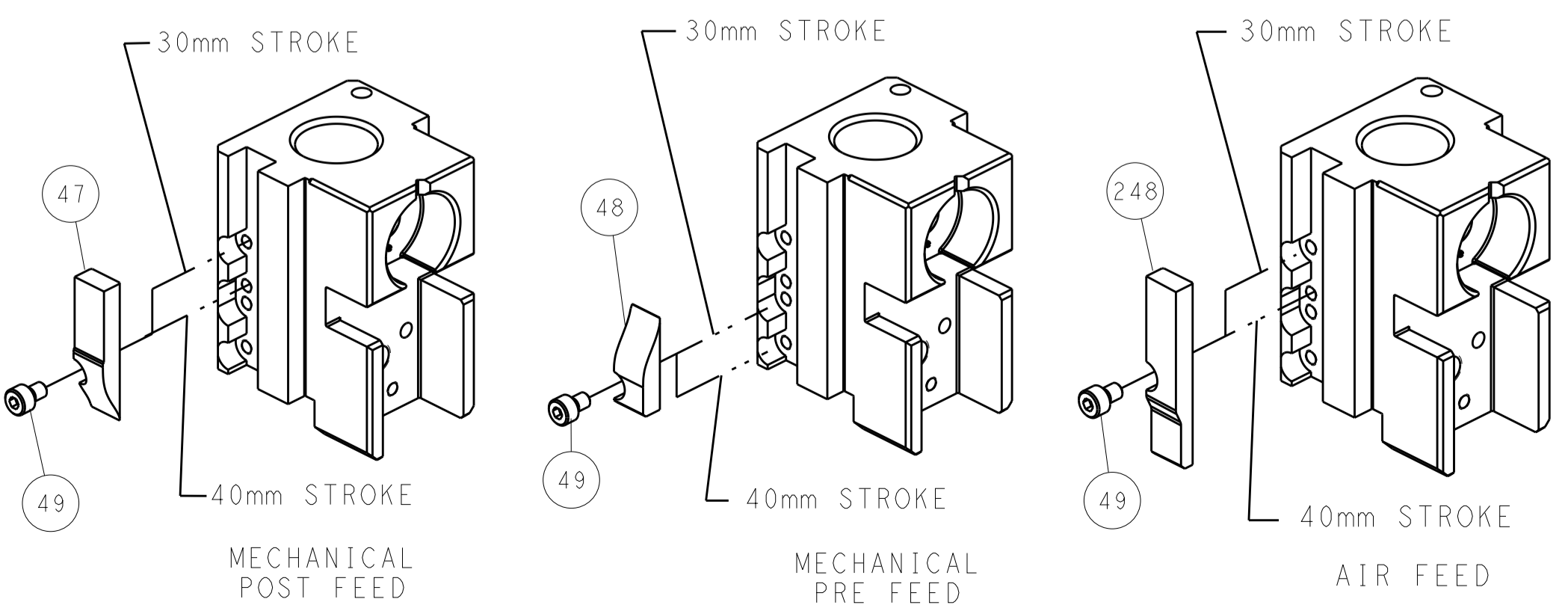

**ATLANTIC VERSION**  
 Shown on sheets 1 of 4 & 2 of 4  
 (Pacific version shown on sheets 3 of 4 & 4 of 4)

THIS DRAWING IS A CONTROLLED DOCUMENT.		DWN: C.CHEN 24AUG2012	<b>STE</b> TE Connectivity
DIMENSIONS: mm		CHK: S.XI 24AUG2012	
TOLERANCES UNLESS OTHERWISE SPECIFIED:		APVD: J. CRUZ 24AUG2012	NAME: Ocean Side Feed Applicator
0 PLC	±	PRODUCT SPEC	APPLICATION SPEC
1 PLC	±	APPLICATOR SPEC	SIZE: A1
2 PLC	±	SCALE: 1:2	SHEET: 2 OF 4
3 PLC	±	REV: G	RESTRICTED TO
4 PLC	±	CAGE CODE: C=2151272	CUSTOMER ACCESSIBLE PRODUCTION DRAWING
ANGLES	±	SCALE: 1:2	SHEET: 2 OF 4
MATERIAL	FINISH	WEIGHT	REV: G



# FEED TYPE MECHANICAL

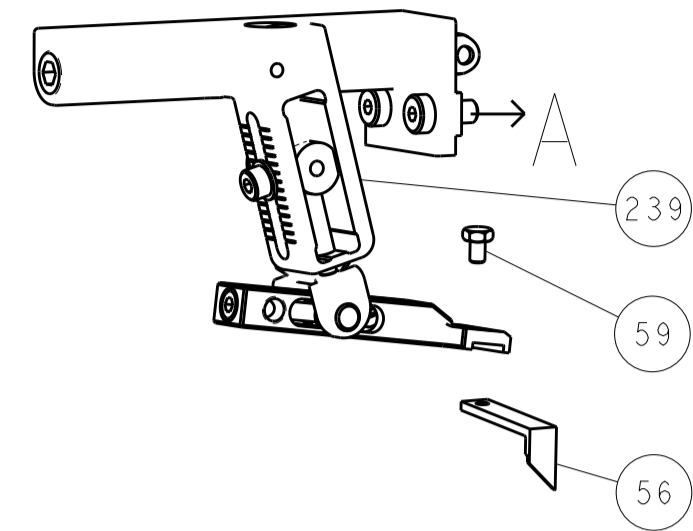

# PNEUMATIC

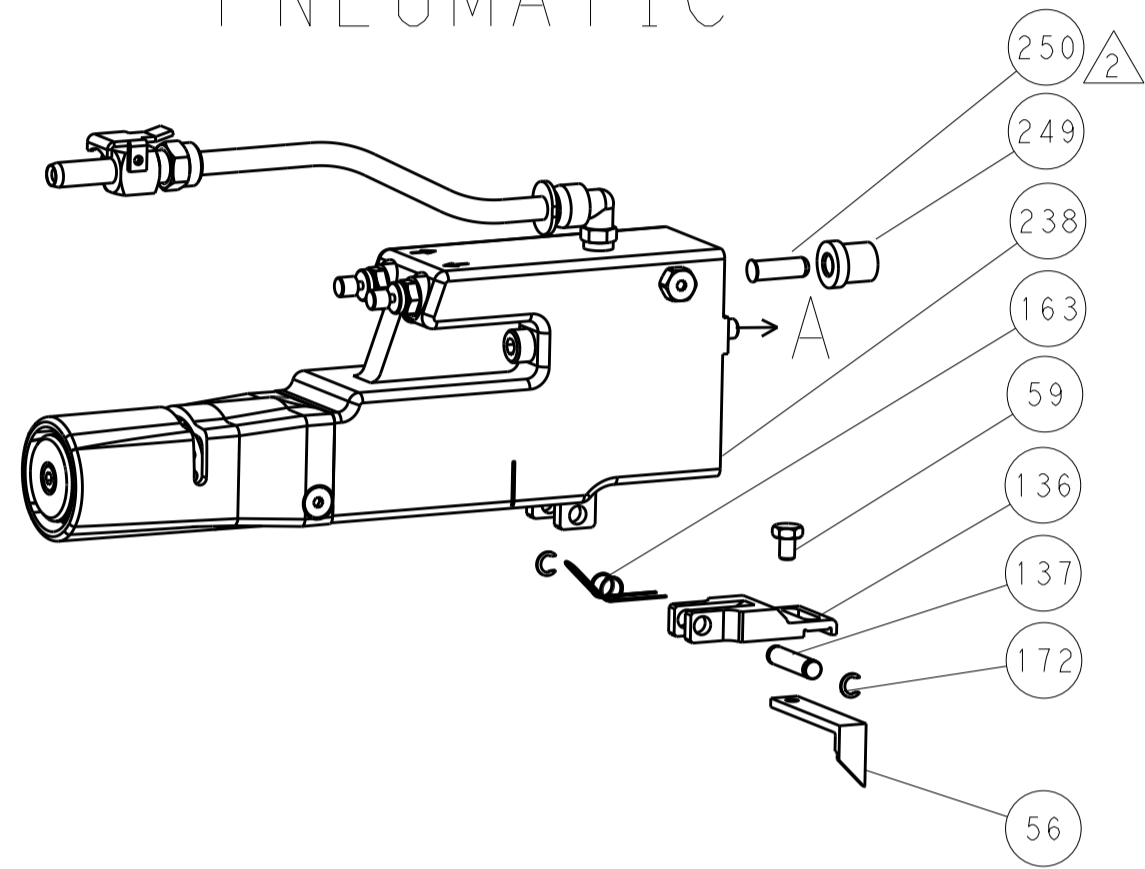

# CAM POSITIONS

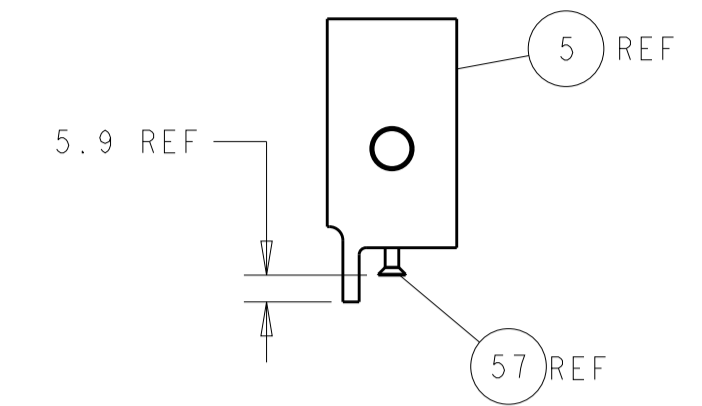
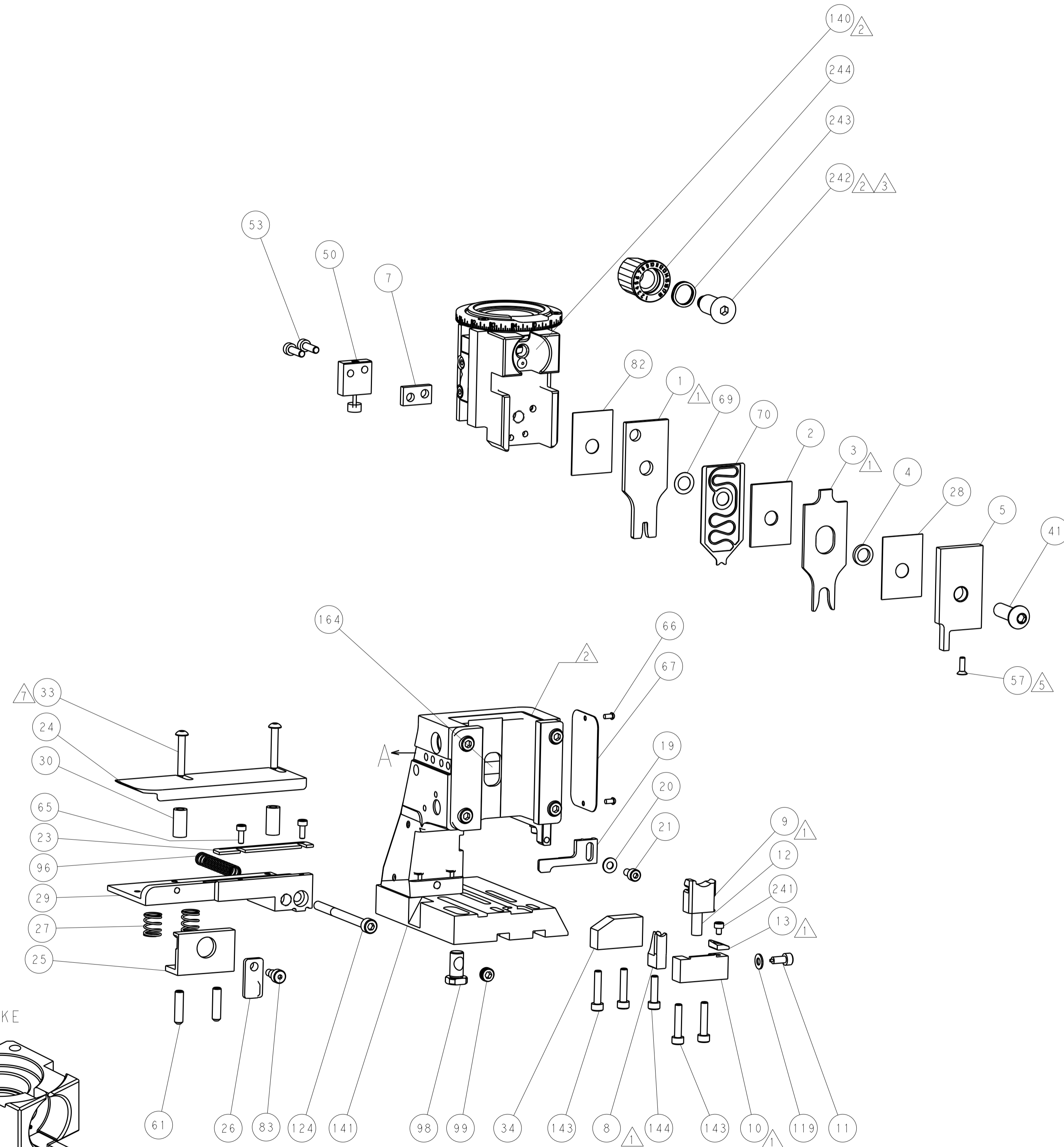
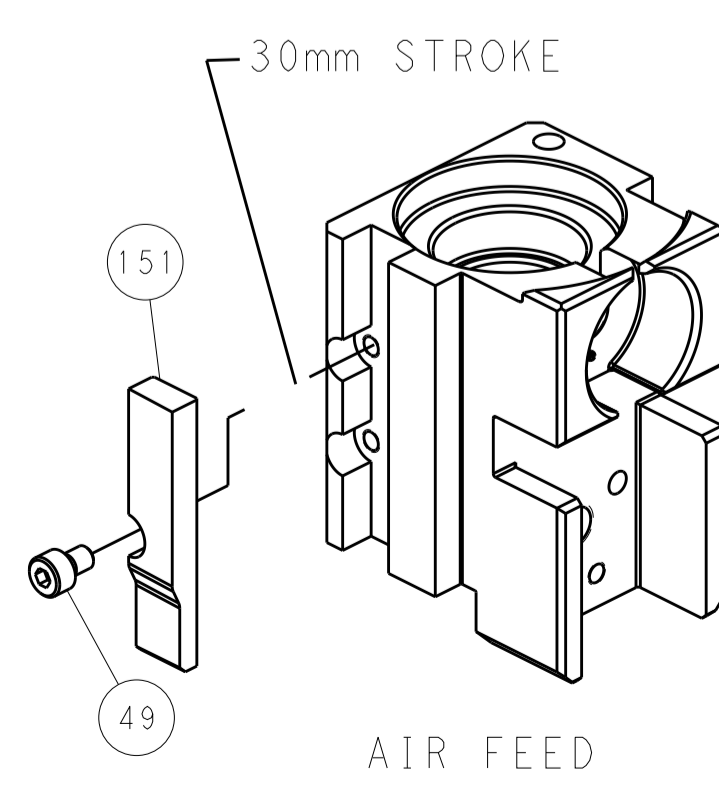
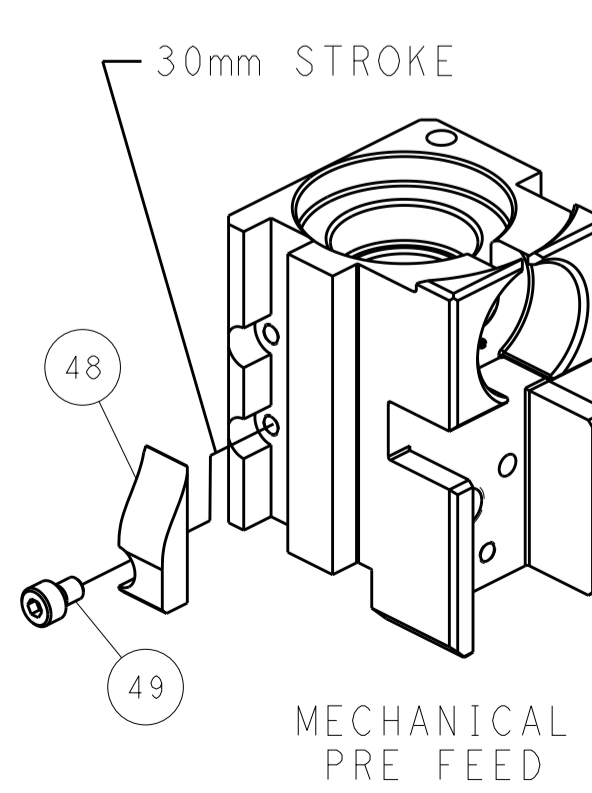
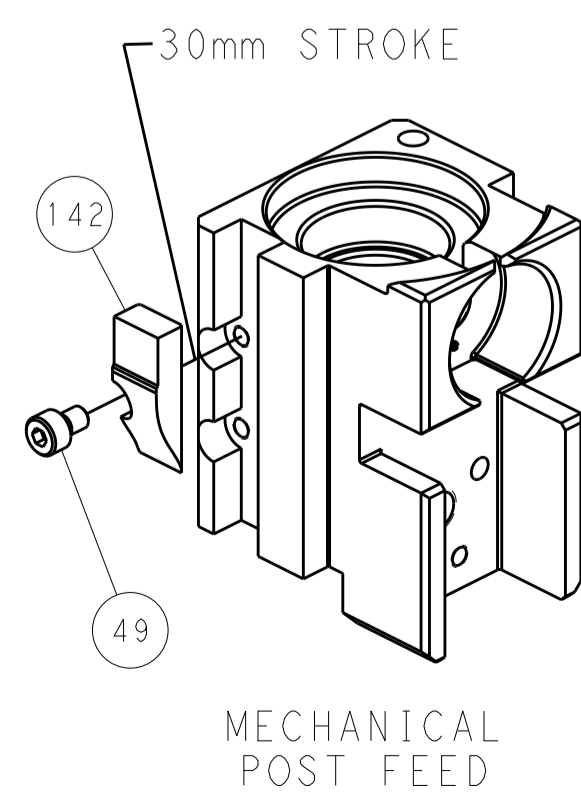

SHEAR DEPRESSOR DETAIL

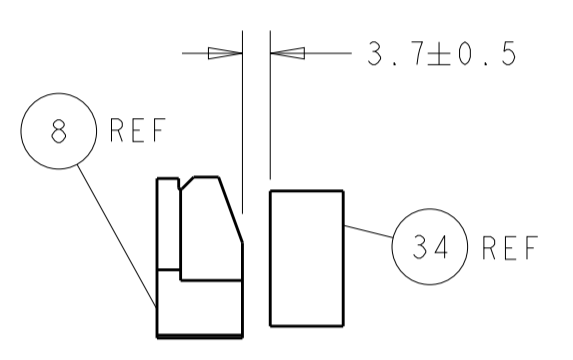

TERMINAL SUPPORT LOCATION

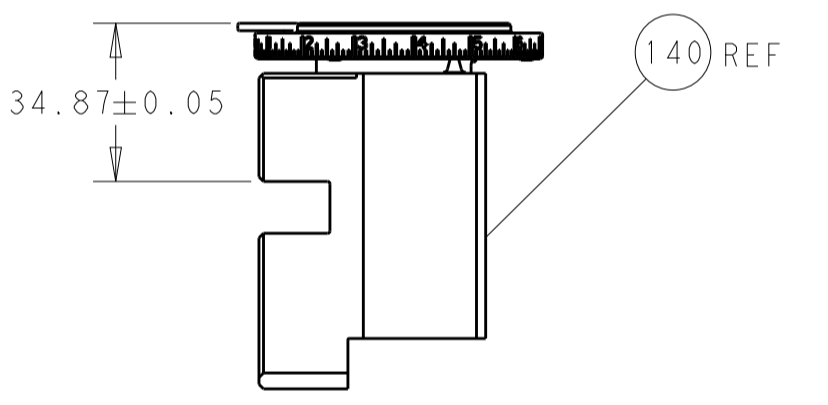

RAM SET-UP

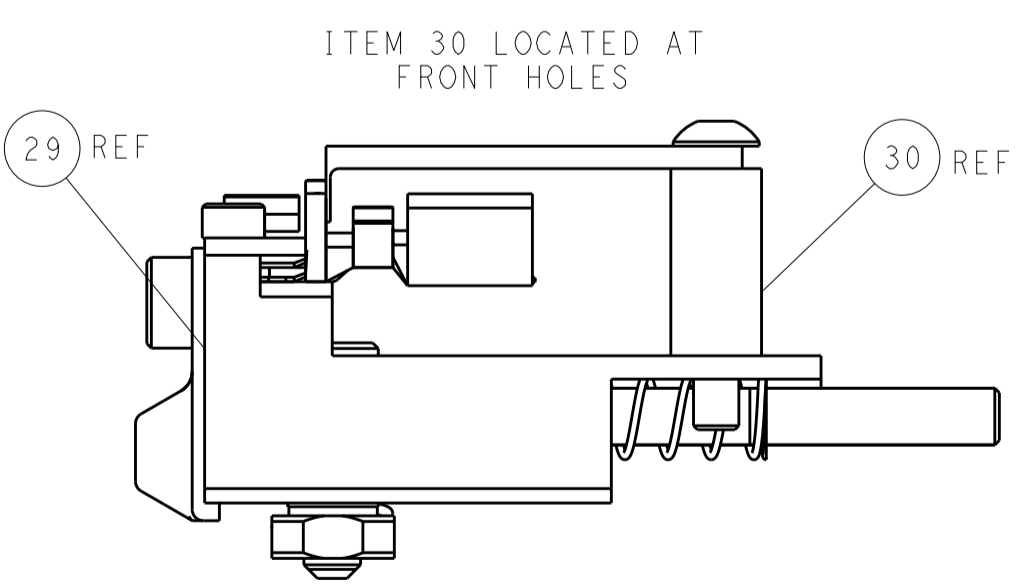

FEED TRACK POSITION  
GUIDE BY INSULATION BARREL

**PACIFIC VERSION**  
Shown on sheets 3 of 4 & 4 of 4  
(Atlantic version shown on sheets 1 of 4 & 2 of 4)

REVISIONS				
P.	LTN.	DESCRIPTION	DATE	APVD.
-	-	SEE SHEET 1	-	-

THIS DRAWING IS A CONTROLLED DOCUMENT.		OWN: J.C. CHEN 24AUG2012	TE Connectivity
DIMENSIONS: mm		CHK: S.XI 24AUG2012	
TOLERANCES UNLESS OTHERWISE SPECIFIED:		APVD: J. CRUZ 24AUG2012	NAME: Ocean Side Feed Applicator
0 PLC ±		PRODUCT SPEC	APPLICATION SPEC
1 PLC ±		APPLICATOR SPEC	SIZE: A1
2 PLC ±		SCALE: 1:2	SHEET 4 OF 4
3 PLC ±		RESTRICTED TO	REV G
4 PLC ±		CUSTOMER ACCESSIBLE PRODUCTION DRAWING	
ANGLES ±			
FINISH			