

PART NUMBER	REVISION	DESCRIPTION	FEED TYPE
2151038-1	N	FINE CRIMP HEIGHT ADJUST	MECHANICAL
2151038-2	N	FINE CRIMP HEIGHT ADJUST	PNEUMATIC
5-2151038-1	N	SEAL STRIPPER CRIMPER TERMINATING UNIT	MECHANICAL
5-2151038-2	N	SEAL STRIPPER CRIMPER TERMINATING UNIT	PNEUMATIC
7-2151038-1	N	MECHANICAL AND CRIMP TOOLING KIT	MECHANICAL
7-2151038-2	N	PNEUMATIC AND CRIMP TOOLING KIT	PNEUMATIC
7-2151038-7	A	CRIMP TOOLING KIT	-

ATLANTIC VERSION TERMINATOR INTERFACE ADAPTER

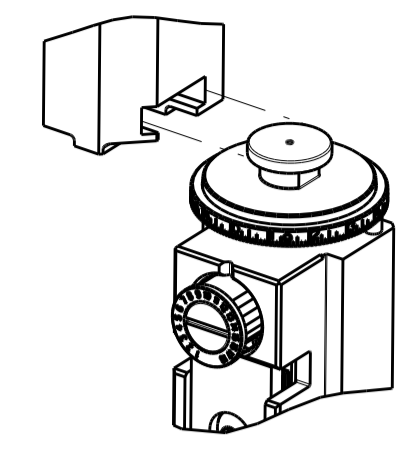

APPLICATOR DATA

CRIMP	SIZE	TYPE
WIRE	1.40 mm [.055]	F
INSUL	2.90 mm [.114]	O

APPLICATOR INSTRUCTIONS 408-35042

TERMINAL DATA: TE TERMINAL TE CRIMP SPECIFICATION

TERMINAL NAME: MQS SOCKET CONTACT

WIRE STRIP LENGTH	INSULATION DIAMETER RANGE
3.35-3.65 mm [1.32-.144 IN]	Ø

TERMINAL APPLICATION SPECIFICATION 114-18025

TERMINALS APPLIED

TE TERMINAL	TE TERMINAL	TE SEAL	TE SEAL	CABLE DIAMETER
965906-1	6-965906-5		967067-1	Ø1.45-1.6
965906-5	7-965906-5		967067-2	Ø1.3-1.4
965906-6	965908-1			
1-965906-5	965908-2			
2-965906-5	2-965908-2			
5-965906-1	5-965908-1			
5-965906-5	5-965908-2			
5-965906-6	5-965908-3			
	7-965908-2			

WIRE SIZE	CRIMP HEIGHT mm [INCH]	CRIMP HEIGHT REFERENCE SETTING
0.75mm2	1.07+/-0.03 [0.42+/-0.001]	6.3
0.50mm2	0.93+/-0.03 [0.37+/-0.001]	7.7

- 1 RECOMMENDED SPARE PARTS
 - 2 REFER TO SUPPLIED INSTRUCTION SHEET FOR CLEANING, LUBRICATION AND STORAGE OF APPLICATOR.
 - 3 APPLY PART NUMBER 1-23419-5 LOCTITE TO THREADS OF ITEMS 180. APPLY PART NUMBER 2-23419-6 LOCTITE TO THREADS OF ITEM 242.
 - 4 CRIMP HEIGHT REFERENCE SETTING WAS THE SETTING USED WHEN THE APPLICATOR WAS QUALIFIED AT THE FACTORY. ADJUSTMENT MAY BE NECESSARY WHEN RUNNING APPLICATOR IN THE FIELD.
 - 5 APPLY TORQ-SEAL IN ALLEN SOCKET TO FILL HOLE AFTER FLAT HD HAS BEEN ADJUSTED TO CORRECT HEIGHT AT QUALIFICATION. APPLY #1-23419-5 LOC-TITE TO THREADS.
 - 6 TERMINAL LUBRICANT IS RECOMMENDED.
7. UNLESS SPECIFIED OTHERWISE TORQUE VALUES SHALL BE USED PER DOCUMENT, 101-35000.

***WARNING**
 ON INSTALLATION, SET WIRE DISC TO CRIMP HEIGHT REFERENCE SETTING FOR LARGEST WIRE SIZE. CRIMP HEIGHT REFERENCE SETTINGS GREATER THAN THE VALUE SHOWN MAY CAUSE DAMAGE TO THE CRIMP TOOLING, REFER TO THE INSTRUCTION SHEET FOR PROPER SETUP AND ADJUSTMENTS.

ATLANTIC VERSION
 Shown on sheets 1 of 4 & 2 of 4
 (Pacific version shown on sheets 3 of 4 & 4 of 4)

LOC	DIST	REV	LTN	DESCRIPTION	DATE	OWN	APVD
A	66						
		L1		ECR-18-012079	30JUL2018	FZ	KZ
		L2		ECR-18-017225	31OCT2018	TB	GB
		M		ECR-19-005216	01APR2019	JAH	CT
		N		ECR-20-005364	14APR2020	MZ	YY

-	-	-	1	1	-	-	1803515-3	RAM ASSEMBLY, SF ATLANTIC	293
-	-	-	1	1	-	-	2-1803583-1	APPLICATOR BASIC ASSEMBLY, SF	292
-	1	-	1	-	1	-	2119641-1	FEED CAM, AIR FEED	248
-	1	1	1	1	1	1	2119082-4	CAM, SNAIL, INSULATION ADJUSTMENT	244
-	1	1	1	1	1	1	2079764-1	WASHER, WAVE SPRING, CREST-TO-CREST	243
3	-	1	1	1	1	1	2119083-1	RETAINER, INSULATION DIAL	242
-	1	1	1	1	1	1	7-18023-7	SCR, SKT HD CAP M3 X 4.0	241
-	-	1	-	1	-	1	2119580-1	MECHANICAL FEED ASSEMBLY	239
-	1	-	1	-	1	-	2844940-1	AIR FEED MODULE	238
-	-	-	1	1	-	-	4-1722335-3	STRIPPER, SIDE FEED	182
3	-	-	1	1	-	-	1-5018030-0	NUT, HEX, REG, RoHS, M3.5	181
-	-	-	1	1	-	-	1-1752354-7	STANDOFF,HOLD-DOWN	180
-	-	-	1	1	-	-	9931111-1	PIN, SLOTTED SPRING 3.0 X 20.0	177
-	-	-	1	1	-	-	5-22280-0	SPRING, COMPRESSION	176
-	-	-	1	1	-	-	1752353-3	GUIDE PIN,HOLDDOWN	175
-	-	-	1	1	-	-	1901680-2	GUIDE PIN,HOLDDOWN	174
-	REF	REF	REF	REF	REF	REF	994970-2	COUNTER, MAGNETIC	164
6	-	1	1	1	1	1	2119955-1	ASSY, LUBRICATOR, SIDE FEED	113
-	1	1	1	1	1	1	2844908-1	SCREW, LOCKING	99
-	1	1	1	1	1	1	2844907-1	POST, LOCKING	98
-	1	1	1	1	1	1	455888-5	SPACER, CRIMPER	82
-	1	1	1	1	1	1	1803607-3	DOCUMENTATION PACKAGE	71
-	1	1	1	1	1	1	2119791-9	DEPRESSOR, WIRE	70
-	1	1	1	1	1	1	2119740-1	TAG,IDENTIFICATION	67
-	2	2	2	2	2	2	2168078-1	SCREW, DRIVE, RH, RoHS, 2 x .188	66
-	1	1	1	1	1	1	2168083-2	SCR, SKT HD CAP, RoHS, M4 X 8.0	60
-	1	1	1	1	1	1	5-18022-5	SCR, HEX HD CAP, M4 X 6.0	59
5	-	1	1	1	1	1	985575-4	SCR, FLT SKT HD CAP M3 X 12.0	57
-	1	1	1	1	1	1	1338685-1	PAWL, FEED	56
-	4	4	4	4	4	4	2168083-3	SCR, SKT HD CAP, RoHS, M4 X 12.0	54
-	2	2	2	2	2	2	2168083-3	SCR, SKT HD CAP, RoHS, M4 X 12.0	53
-	1	1	1	1	1	1	1803382-4	HOLD DOWN, SPRING LOADED	50
-	1	2	1	2	1	2	18023-9	SCR, SKT HD CAP M4 X 6.0	49
-	-	1	-	1	-	1	2119652-1	FEED CAM, PRE FEED	48
-	-	1	-	1	-	1	2119653-1	FEED CAM, POST FEED	47
-	1	1	-	-	1	1	1803583-9	APPLICATOR BASIC ASSEMBLY, SF	46
-	1	1	-	-	1	1	1803515-1	RAM ASSEMBLY, SF ATLANTIC	44
-	1	1	1	1	1	1	1803602-1	SCR, BHSC, RoHS (M8 X 25)	41
-	1	1	1	1	1	1	1752356-6	SUPPORT, TERMINAL	34
-	2	2	2	2	2	2	2079383-5	SCR, BHSC, RoHS (M4 X 20)	33
-	2	2	2	2	2	2	2-2844962-8	SPACER, CYLINDRICAL, STRIP GUIDE	30
-	1	1	1	1	1	1	2844992-1	ASSEMBLY, STRIP GUIDE	29
-	1	1	1	1	1	1	455888-6	SPACER, CRIMPER	28
-	1	1	1	1	1	1	1320928-2	STRIP GUIDE	24
-	1	1	-	-	1	1	2168083-2	SCR, SKT HD CAP, RoHS, M4 X 8.0	21
-	2	2	1	1	2	2	1-18028-2	WASHER, FLAT, REG M4	20
-	1	1	-	-	1	1	2119533-1	STRIPPER, SIDE FEED	19
1	-	1	1	1	1	1	2119806-1	INSERT, SHEAR	13
-	1	1	1	1	1	1	3-22280-3	SPRING, COMPRESSION	12
-	1	1	1	1	1	1	1-356885-4	STOP, SHEAR	11
-	1	1	1	1	1	1	2119805-1	SHEAR HOLDER, FRONT	10
1	-	1	1	1	1	1	318707-1	FLOATING SHEAR, FRONT	9
1	2	2	1	1	1	1	1-1333201-0	ANVIL, COMBINATION	8
-	1	1	1	1	1	1	5-240641-4	SPACER	7
-	-	-	-	-	-	-	-	-	6
-	1	1	1	1	1	1	2119781-1	DEPRESSOR, SHEAR	5
-	1	1	1	1	1	1	238011-4	BLOCK, CRIMPER SPACER	4
1	2	2	1	1	1	1	1-2119784-5	CRIMPER, INSULATION O PREMIUM	3
-	1	1	1	1	1	1	455888-1	SPACER, CRIMPER	2
1	2	2	1	1	1	1	1-456402-7	CRIMPER, WIRE PREMIUM	1

ITEM NO	PART NO	DESCRIPTION	ITEM NO
-77	-72	-71	-52
-51	-2	-1	

DATE: 13NOV2012	CHK: R.KNEPPER	DATE: 13NOV2012	CHK: T.ELBIN
DATE: 13NOV2012	CHK: M.CLEFFORD	DATE: 13NOV2012	CHK: M.CLEFFORD

TE Connectivity
 Harrisburg, PA 17105-3608

Ocean Side Feed
 Applicator

SIZE: A1 CAGE CODE: 00779 DRAWING NO: 2151038

Customer Accessible Production Drawing SCALE: 1:2 SHEET 1 OF 4 REV: N

LOC	DIST	REVISIONS					
A	66	P	LTN	DESCRIPTION	DATE	OWN	APVD
		-		SEE SHEET 1			

FEED TYPE MECHANICAL

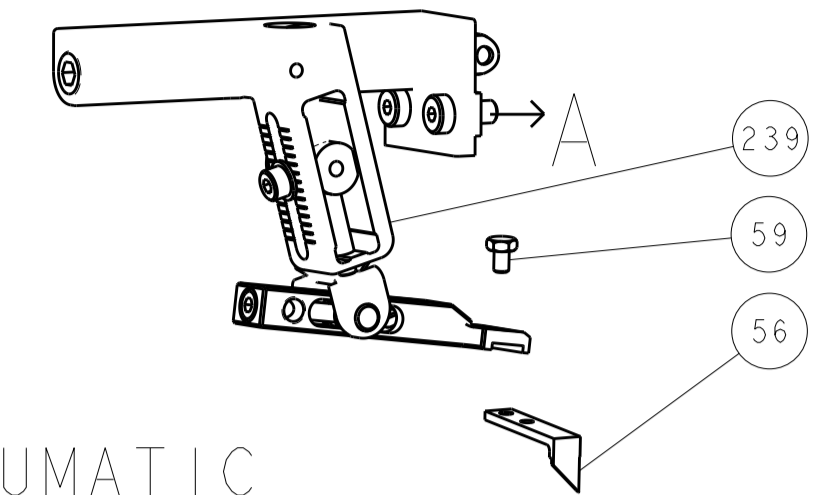

PNEUMATIC

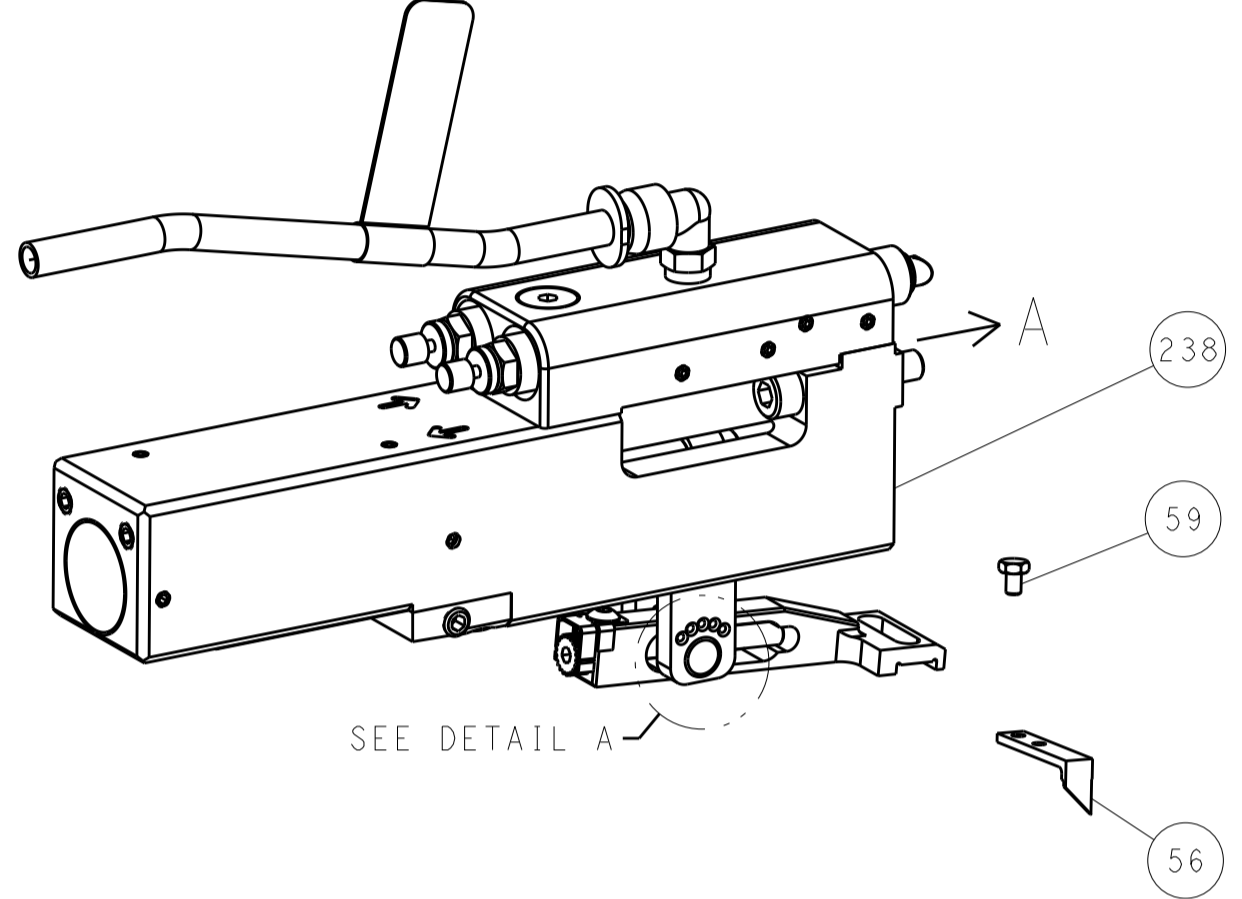

FEED SPRING SETTING POSITION (SHOWN FROM REAR SIDE)



DETAIL A

CAM POSITIONS

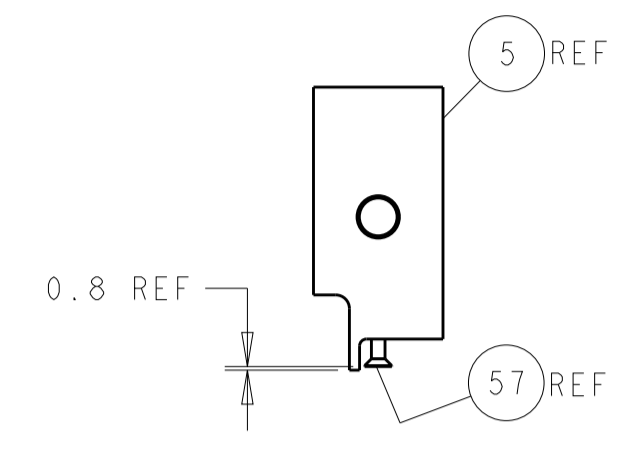
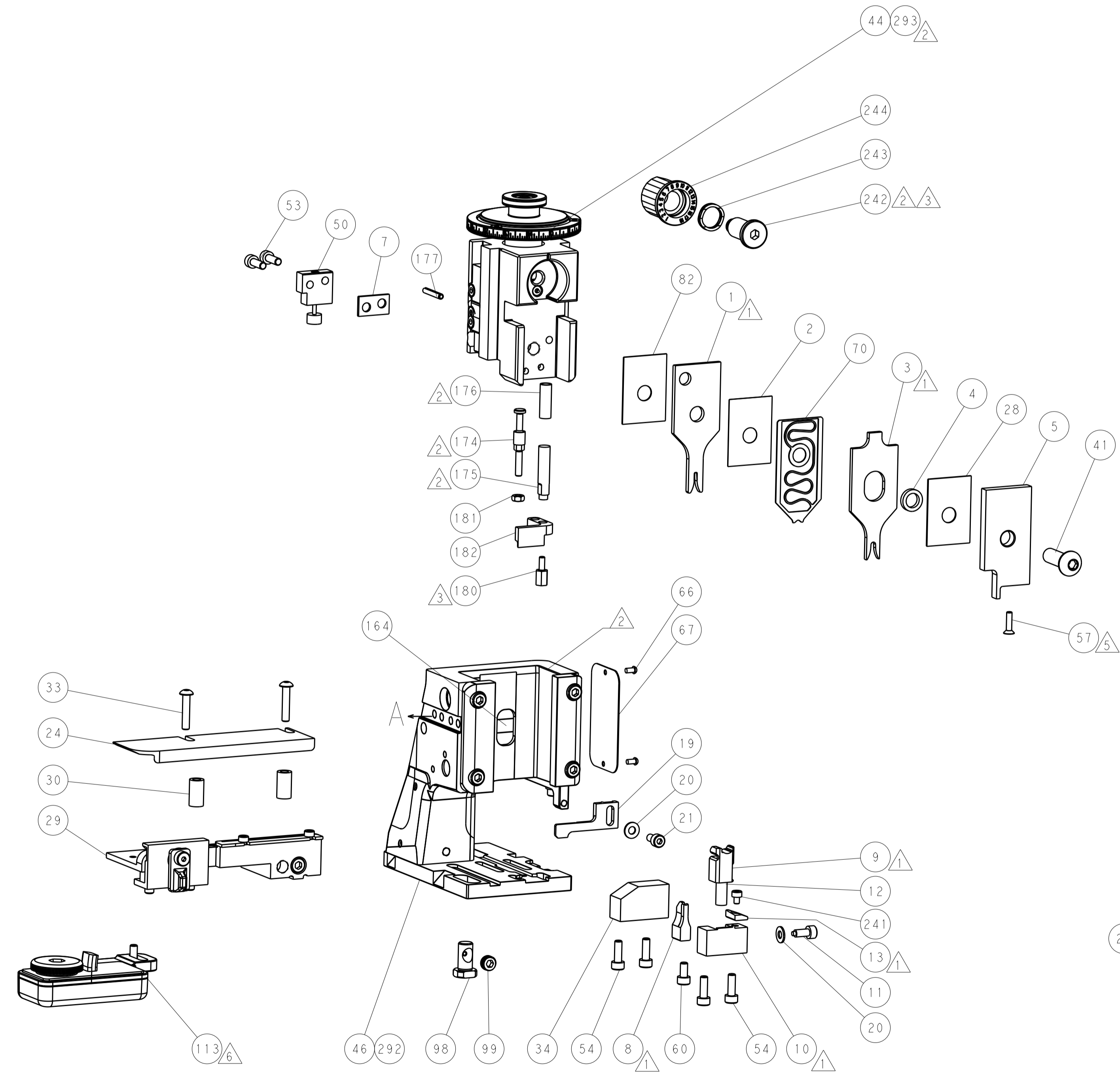

SHEAR DEPRESSOR DETAIL

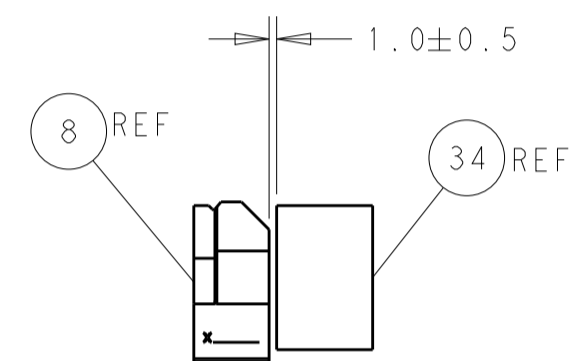

TERMINAL SUPPORT LOCATION

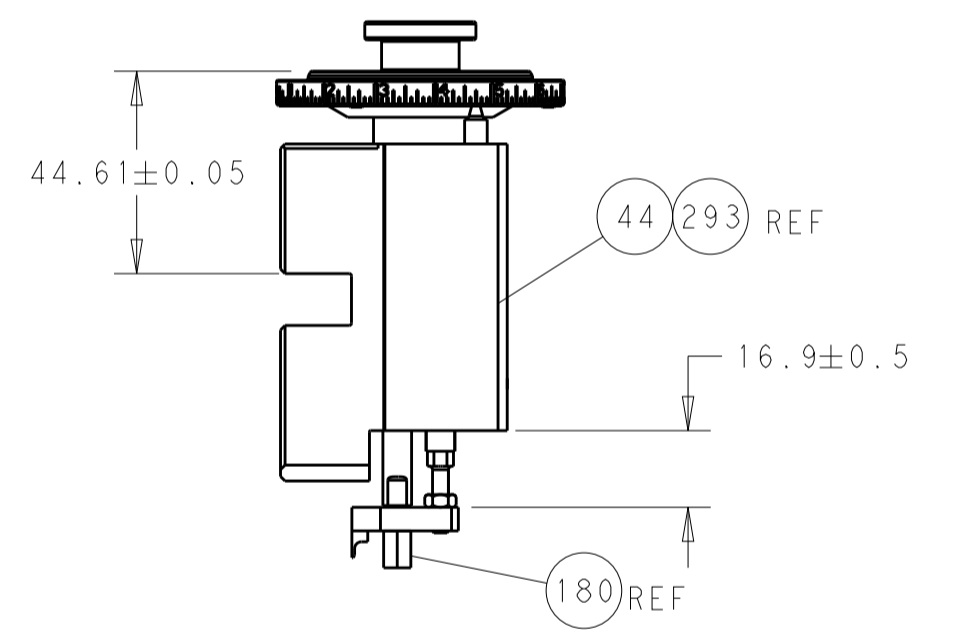

RAM AND HOLDDOWN SET-UP

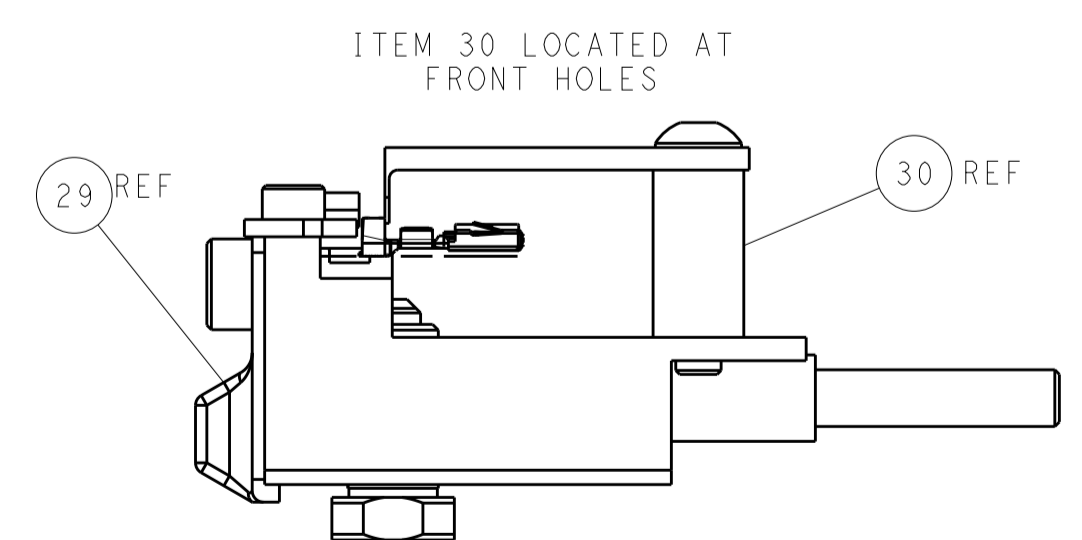

FEED TRACK POSITION GUIDE BY INSULATION BARREL

ATLANTIC VERSION
 Shown on sheets 1 of 4 & 2 of 4
 (Pacific version shown on sheets 3 of 4 & 4 of 4)

DIMENSIONS:		TOLERANCES UNLESS OTHERWISE SPECIFIED:		DWN R. KNEPPER 13NOV2012		TE Connectivity	
mm	0 PLC ±	1 PLC ±	2 PLC ±	3 PLC ±	4 PLC ±	5 PLC ±	Harrisburg, PA 17105-3608
	ANGLES			APVD M. CLIFFORD 13NOV2012	NAME	Ocean Side Feed Applicator	
MATERIAL	FINISH	WEIGHT	SCALE	Customer Accessible Production Drawing	SIZE	CAGE CODE	DRAWING NO
			1:2		A1	00779	2151038
				SHEET 2 OF 4		REV N	

PART NUMBER	REVISION	DESCRIPTION	FEED TYPE
2-2151038-1	N	FINE CRIMP HEIGHT ADJUST	MECHANICAL
2-2151038-2	N	FINE CRIMP HEIGHT ADJUST	PNEUMATIC
7-2151038-7	A	CRIMP TOOLING KIT	-

PACIFIC VERSION TERMINATOR
 INTERFACE ADAPTER



APPLICATOR DATA		
CRIMP	SIZE	TYPE
WIRE	1.40 mm [.055]	F
INSUL	2.90 mm [.114]	O

APPLICATOR INSTRUCTIONS
 408-35042

TERMINAL DATA: TE TERMINAL		TE CRIMP SPECIFICATION	
TERMINAL NAME: MQS SOCKET CONTACT			
WIRE STRIP LENGTH		INSULATION DIAMETER RANGE	
3.35-3.65 mm [.132-.144 IN]		∅	
TERMINAL APPLICATION SPECIFICATION	114-18025		

TERMINALS APPLIED				
TE TERMINAL	TE TERMINAL	TE SEAL	TE SEAL	CABLE DIAMETER
965906-1	6-965906-5		967067-1	∅1.45-1.6
965906-5	7-965906-5		967067-2	∅1.3-1.4
965906-6	965908-1			
1-965906-5	965908-2			
2-965906-5	2-965908-2			
5-965906-1	5-965908-1			
5-965906-5	5-965908-2			
5-965906-6	5-965908-3			
	7-965908-2			

WIRE SIZE	CRIMP HEIGHT mm [INCH]	CRIMP HEIGHT REFERENCE SETTING
0.75mm2	1.07 +/- 0.03 [.042 +/- .001]	6.3
0.50mm2	0.93 +/- 0.03 [.037 +/- .001]	7.7

- RECOMMENDED SPARE PARTS
 - REFER TO SUPPLIED INSTRUCTION SHEET FOR CLEANING, LUBRICATION AND STORAGE OF APPLICATOR.
 - APPLY PART NUMBER 2-23419-6 LOCTITE TO THREADS OF ITEM 242.
 - CRIMP HEIGHT REFERENCE SETTING WAS THE SETTING USED WHEN THE APPLICATOR WAS QUALIFIED AT THE FACTORY. ADJUSTMENT MAY BE NECESSARY WHEN RUNNING APPLICATOR IN THE FIELD.
 - APPLY TORQ-SEAL IN ALLEN SOCKET TO FILL HOLE AFTER FLAT HD HAS BEEN ADJUSTED TO CORRECT HEIGHT AT QUALIFICATION. APPLY #1-23419-5 LOC-TITE TO THREADS.
 - TERMINAL LUBRICANT IS RECOMMENDED.
7. UNLESS SPECIFIED OTHERWISE TORQUE VALUES SHALL BE USED PER DOCUMENT, 101-35000.

***WARNING**
 ON INSTALLATION, SET WIRE DISC TO CRIMP HEIGHT REFERENCE SETTING FOR LARGEST WIRE SIZE. CRIMP HEIGHT REFERENCE SETTINGS GREATER THAN THE VALUE SHOWN MAY CAUSE DAMAGE TO THE CRIMP TOOLING, REFER TO THE INSTRUCTION SHEET FOR PROPER SETUP AND ADJUSTMENTS.

LOC	DIST	REVISIONS					
		P	LTN	DESCRIPTION	DATE	OWN	APVD
A	66	-	-	SEE SHEET 1	-	-	-

-	1	1	2119082-4	CAM, SNAIL, INSULATION ADJUSTMENT	244
-	1	1	2079764-1	WASHER, WAVE SPRING, CREST-TO-CREST	243
3	-	1	2119083-1	RETAINER, INSULATION DIAL	242
-	1	1	7-18023-7	SCR, SKT HD CAP M3 X 4.0	241
-	-	1	2119580-1	MECHANICAL FEED ASSEMBLY	239
-	1	-	2844940-1	AIR FEED MODULE	238
-	REF	REF	994970-2	COUNTER, MAGNETIC	164
-	1	-	2119641-2	FEED CAM, AIR FEED	151
-	1	1	2168083-8	SCR, SKT HD CAP, RoHS, M4 X 16	144
-	4	4	2168083-9	SCR, SKT HD CAP, RoHS, M4 X 20	143
-	-	1	2119653-2	FEED CAM, POST FEED	142
-	1	1	1-1803583-0	APPLICATOR BASIC ASSEMBLY, SF	141
-	1	1	1803516-1	RAM ASSEMBLY, SF PACIFIC	140
6	-	1	2119955-1	ASSY, LUBRICATOR, SIDE FEED	113
-	1	1	2844908-1	SCREW, LOCKING	99
-	1	1	2844907-1	POST, LOCKING	98
-	1	1	455888-5	SPACER, CRIMPER	82
-	1	1	1803607-3	DOCUMENTATION PACKAGE	71
-	1	1	2119791-9	DEPRESSOR, WIRE	70
-	1	1	2119740-1	TAG, IDENTIFICATION	67
-	2	2	2168078-1	SCREW, DRIVE, RH, RoHS, 2 x .188	66
5	-	1	5-18022-5	SCR, HEX HD CAP, M4 X 6.0	59
-	1	1	985575-4	SCR, FLT SKT HD CAP M3 X 12.0	57
-	1	1	1338685-1	PAWL, FEED	56
-	2	2	2168083-3	SCR, SKT HD CAP, RoHS, M4 X 12.0	53
-	1	1	1803382-4	HOLD DOWN, SPRING LOADED	50
-	1	2	18023-9	SCR, SKT HD CAP M4 X 6.0	49
-	-	1	2119652-1	FEED CAM, PRE FEED	48
-	1	1	1803602-1	SCR, BHSC, RoHS (M8 X 25)	41
-	1	1	1752356-6	SUPPORT, TERMINAL	34
-	2	2	2079383-5	SCR, BHSC, RoHS (M4 X 20)	33
-	2	2	2-2844962-8	SPACER, CYLINDRICAL, STRIP GUIDE	30
-	1	1	2844992-1	ASSEMBLY, STRIP GUIDE	29
-	1	1	455888-6	SPACER, CRIMPER	28
-	1	1	1320928-2	STRIP GUIDE	24
-	1	1	2168083-2	SCR, SKT HD CAP, RoHS, M4 X 8.0	21
-	2	2	1-18028-2	WASHER, FLAT, REG M4	20
-	1	1	2119533-1	STRIPPER, SIDE FEED	19
1	-	1	2119806-1	INSERT, SHEAR	13
-	1	1	3-22280-3	SPRING, COMPRESSION	12
-	1	1	1-356885-4	STOP, SHEAR	11
1	-	1	2119805-1	SHEAR HOLDER, FRONT	10
1	-	1	318707-1	FLOATING SHEAR, FRONT	9
1	1	1	1-1333201-0	ANVIL, COMBINATION	8
-	1	1	5-240641-4	SPACER	7
-	-	-	-	-	6
-	1	1	2119781-1	DEPRESSOR, SHEAR	5
-	1	1	238011-4	BLOCK, CRIMPER SPACER	4
1	1	1	1-2119784-5	CRIMPER, INSULATION O PREMIUM	3
-	1	1	455888-1	SPACER, CRIMPER	2
1	1	1	1-456402-7	CRIMPER, WIRE PREMIUM	1

PACIFIC VERSION
 Shown on sheets 3 of 4 & 4 of 4
 (Atlantic version shown on sheets 1 of 4 & 2 of 4)

DIMENSIONS: mm 		TOLERANCES UNLESS OTHERWISE SPECIFIED: 0 PLC ± 1 PLC ± 2 PLC ± 3 PLC ± 4 PLC ± ANGLES ± FINISH		DWN R. KNEPPER 13NOV2012 CHK T. ELBIN 13NOV2012 APVD M. CLIFFORD 13NOV2012		NAME Ocean Side Feed Applicator	
MATERIAL		FINISH		WEIGHT		SCALE	
				A1 00779		C=2151038	
Customer Accessible Production Drawing				SCALE 1:2		SHEET 3 OF 4	

LOC		DIST		REVISIONS			
A		66		REV	DATE	BY	APPROV
-				SEE SHEET 1	-	-	-

FEED TYPE MECHANICAL

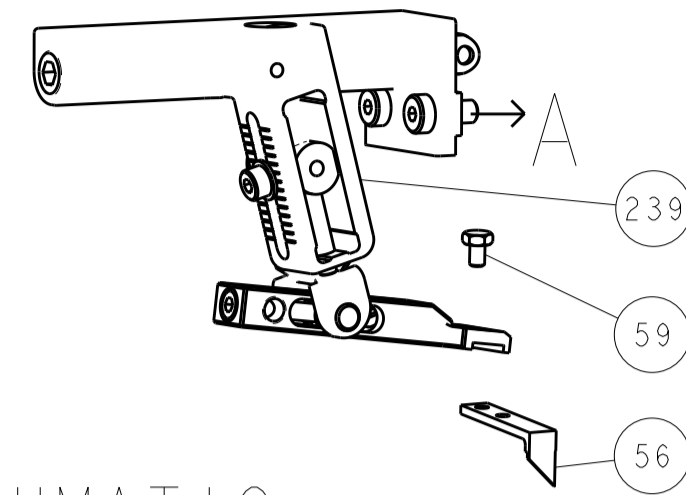

PNEUMATIC

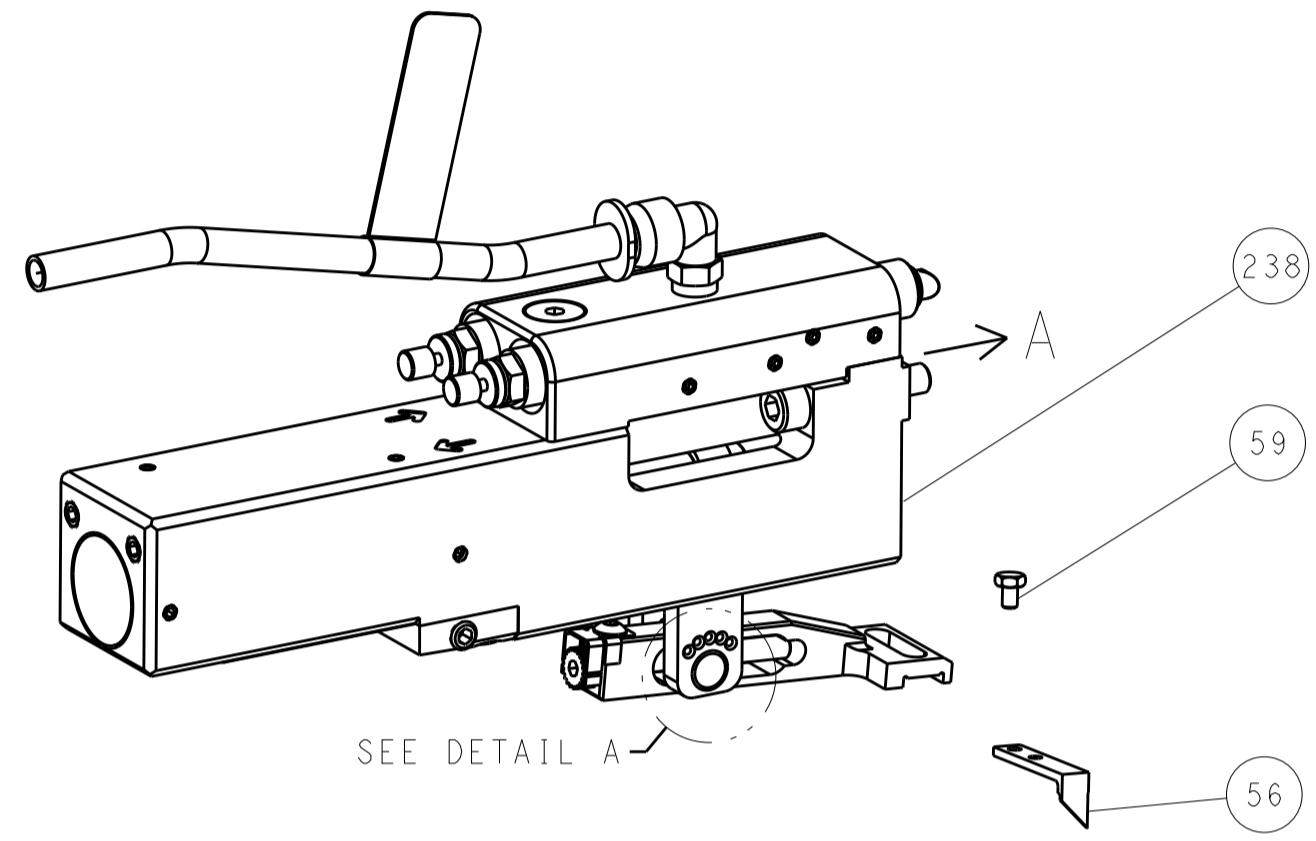

FEED SPRING SETTING POSITION (SHOWN FROM REAR SIDE)



CAM POSITIONS

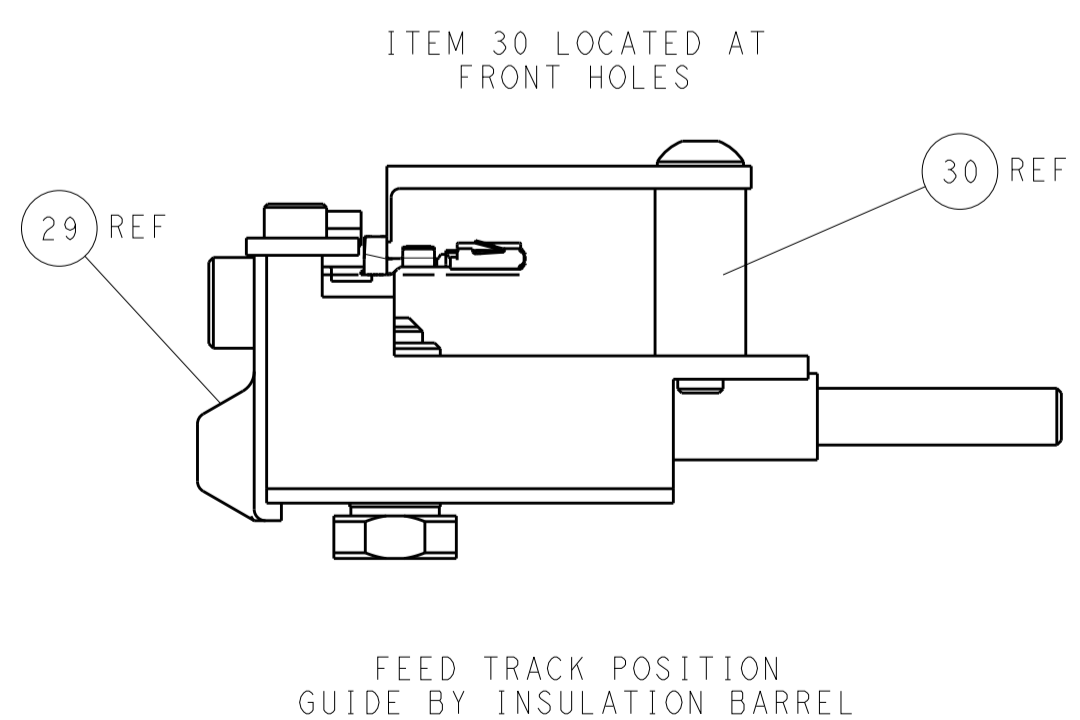
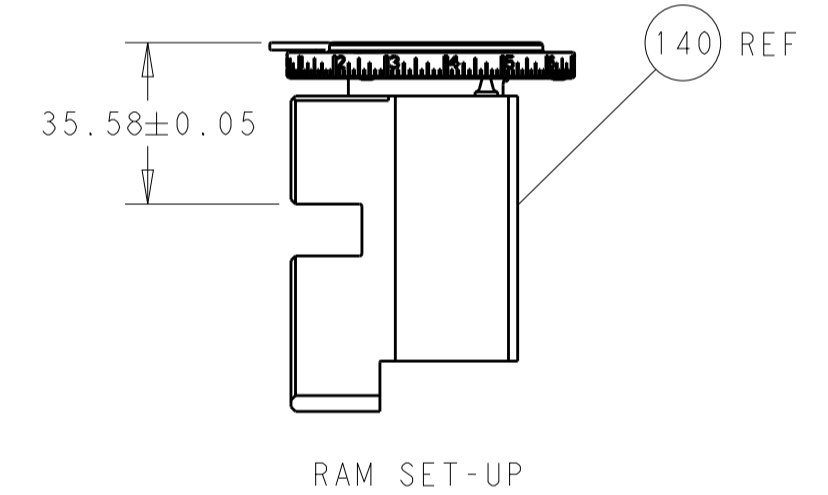
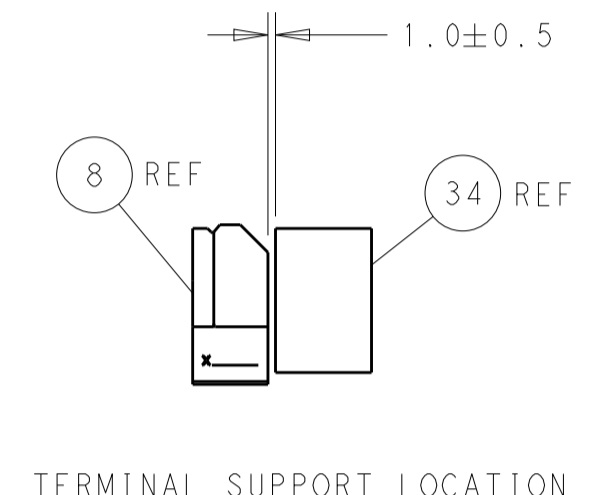
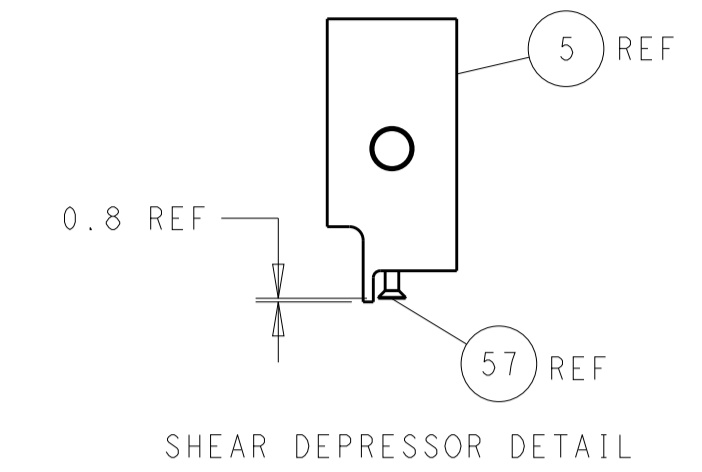
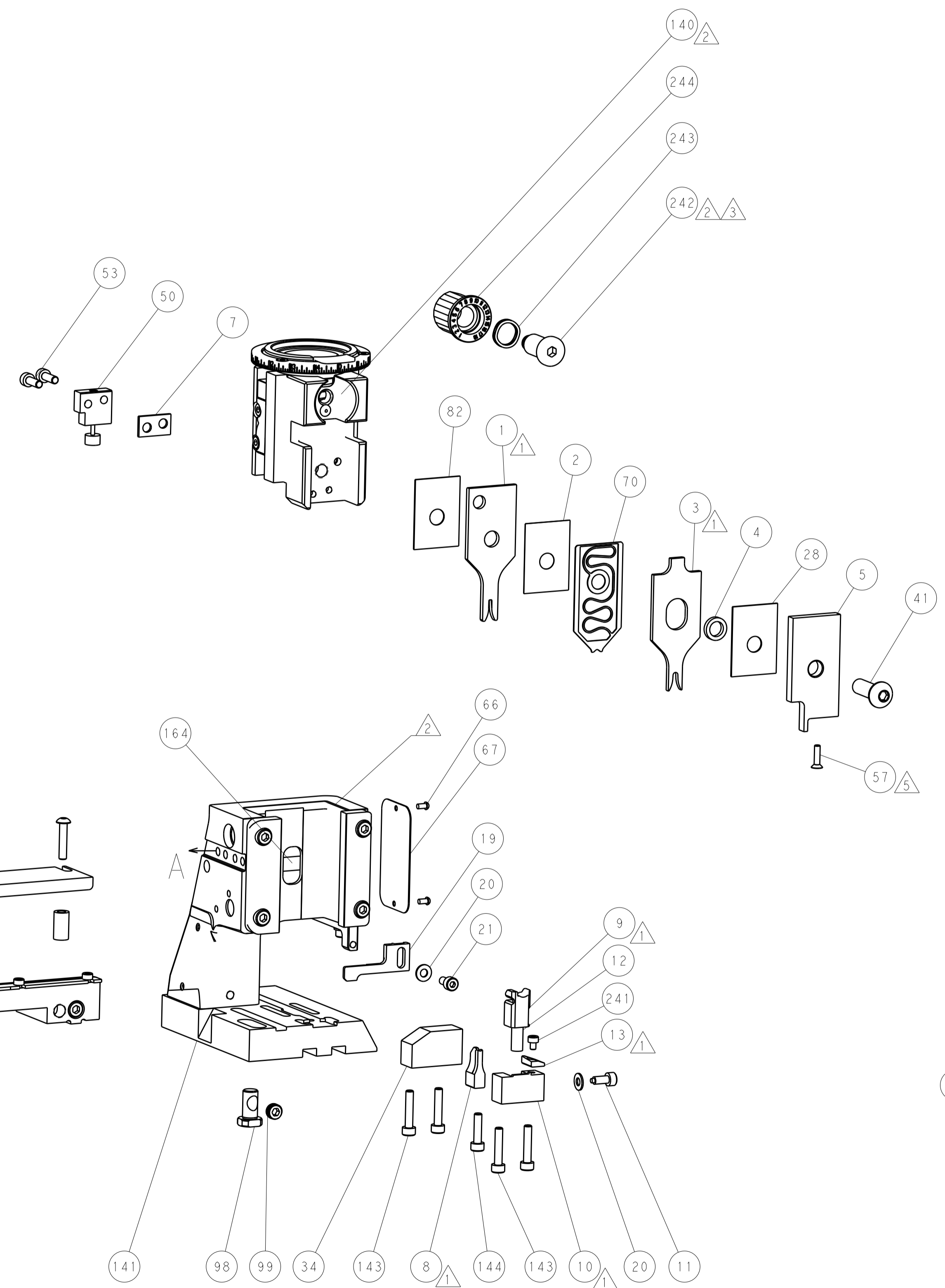
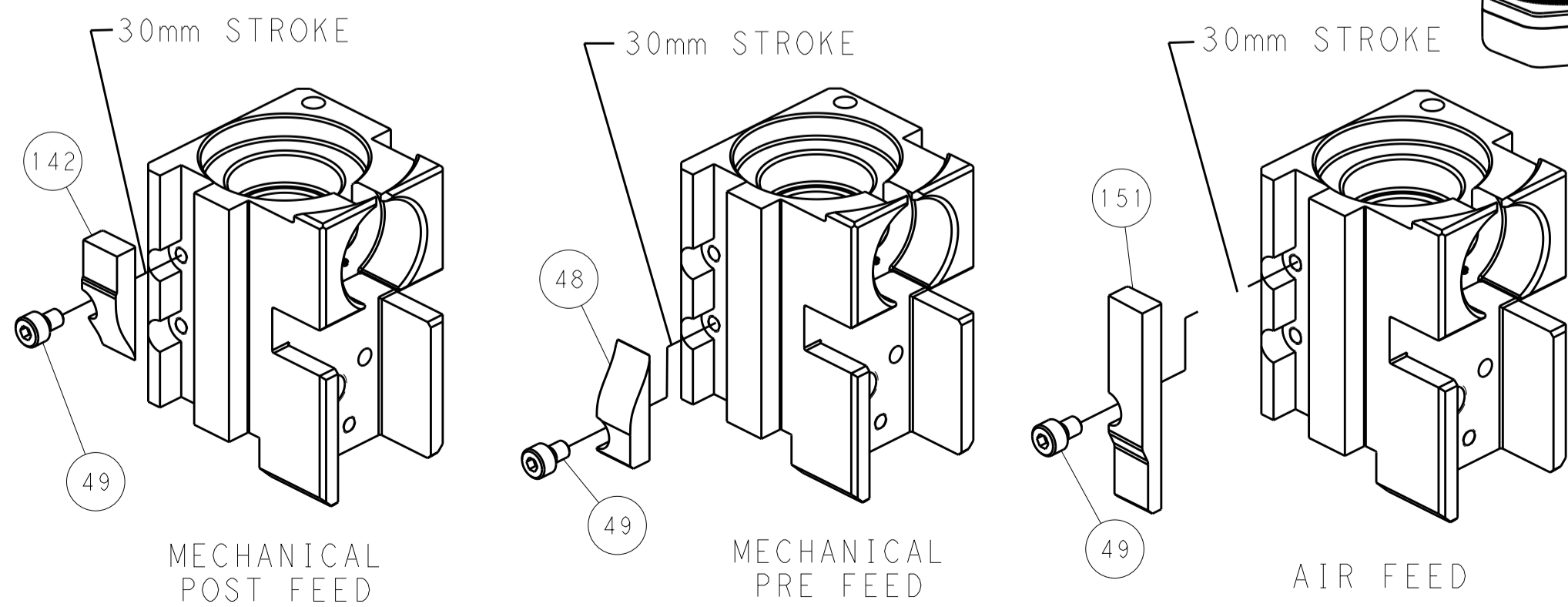

PACIFIC VERSION
 Shown on sheets 3 of 4 & 4 of 4
 (Atlantic version shown on sheets 1 of 4 & 2 of 4)

DIMENSIONS:		TOLERANCES UNLESS OTHERWISE SPECIFIED:		DWG: R. KNEPPER 13NOV2012		TE Connectivity	
mm		0 PLC ±		CHK: T. ELBIN 13NOV2012		Harrisburg, PA 17105-3608	
Ø		1 PLC ±		APVD: M. CLIFFORD 13NOV2012		NAME: Ocean Side Feed Applicator	
H		2 PLC ±		PRODUCT SPEC:		SIZE: CAGE CODE: DRAWING NO:	
D		3 PLC ±		APPLICATION SPEC:		RESTRICTED TO:	
R		4 PLC ±		WEIGHT:		A1 00779 ©=2151038	
ANGLES		FINISH:		Customer Accessible Production Drawing		SCALE: 1:2 SHEET 4 OF 4 REV N	