

PART NUMBER	REVISION	DESCRIPTION	FEED TYPE
2151015-1	B	FINE CRIMP HEIGHT ADJUST	MECHANICAL
2151015-2	C	FINE CRIMP HEIGHT ADJUST	PNEUMATIC
7-2151015-1	B	MECHANICAL AND CRIMP TOOLING KIT	MECHANICAL
7-2151015-2	C	PNEUMATIC AND CRIMP TOOLING KIT	PNEUMATIC
7-2151015-7	A	CRIMP TOOLING KIT	-

ATLANTIC VERSION TERMINATOR INTERFACE ADAPTER

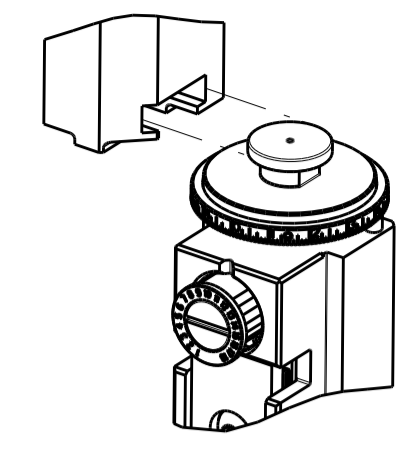

APPLICATOR DATA		
CRIMP	SIZE	TYPE
WIRE	1.58 mm [.062]	F
INSUL	3.18 mm [.125]	F

APPLICATOR INSTRUCTIONS
408-35042

TERMINAL DATA: MOLEX TERMINAL		MOLEX CRIMP SPECIFICATION	
TERMINAL NAME: 4.2mm PITCH MINI-FIT TERMINAL			
WIRE STRIP LENGTH		INSULATION DIAMETER RANGE	
3.00-3.50 mm [.118-.138 IN]		Ø2.50-2.95 mm [.098-.116 IN]	
TERMINAL APPLICATION SPECIFICATION	MOLEX 63900-2600 REV J		

TERMINALS APPLIED			
TE TERMINAL	MOLEX TERMINAL	TE TERMINAL	MOLEX TERMINAL
286603-1	39-00-0038	286611-1	39-00-0040
286603-2	39-00-0055	286611-2	39-00-0061
286603-3	39-00-0207	286611-3	39-00-0053
286603-4	39-00-0163	286611-4	39-00-0120
286603-5	39-00-0059	286611-5	39-00-0126
286603-6	39-00-0153	286611-6	39-00-0219
286603-7	39-00-0181	286611-8	39-00-0411
286603-8	39-00-0213	286611-9	39-00-0430
1-286603-0	44485-1211	1-286611-1	39-00-0121
1-286603-1	39-00-0114	1-286611-2	39-00-0420
1-286603-2	39-00-0428	1-286611-3	39-00-0437
1-286603-3	39-00-0419	1-286611-4	39-00-0426
1-286603-4	39-00-0425	1-286611-6	39-00-0075
1-286603-5	39-00-0436	1-286611-7	39-00-0427
1-286603-6	39-00-0440	1-286611-8	40-13-0853
1-286603-7	39-00-0073	2-286611-0	30490-1002
1-286603-8	39-00-0108	2-286611-1	30490-2002
1-286603-9	39-00-0169	2-286611-2	40-01-0853
2-286603-0	39-00-0175	2-286611-3	98-00-0174
2-286603-1	39-00-0194	2-286611-4	30490-0002
2-286603-2	39-00-0200		
2-286603-3	39-00-0405		
2-286603-4	39-00-0407		
2-286603-5	39-00-0410		
2-286603-6	40-13-0851		
2-286603-8	44485-1311		
2-286603-9	44485-1411		

TERMINAL DATA: MOLEX TERMINAL		CMOLEX CRIMP SPECIFICATION	
TERMINAL NAME: 4.2mm PITCH MINI-FIT TERMINAL			
WIRE STRIP LENGTH		INSULATION DIAMETER RANGE	
3.00-3.50 mm [.118-.138 IN]		Ø2.50-2.95 mm [.098-.116 IN]	
TERMINAL APPLICATION SPECIFICATION	MOLEX 63900-2600 REV J		

TERMINALS APPLIED			
TE TERMINAL	MOLEX TERMINAL	TE TERMINAL	MOLEX TERMINAL
286603-9	44476-1111	1-2113022-1	46083-1211
2-286603-7	44476-1211	1-2113022-2	46083-1221
286611-7	44478-1111	1-2113022-3	46134-1111
1-286611-9	44478-1211	1-2113022-4	46134-1121
2113022-1	45750-1211	1-2113022-5	46134-1211
2113022-2	45750-1111	1-2113022-6	46134-1221
2113022-3	46012-1111		
2113022-4	46018-1541		
2113022-5	46083-1111		
2113022-6	46098-1541		
2113022-7	46012-1141		
2113022-8	46012-1211		
2113022-9	46012-1241		
1-2113022-0	46083-1121		

WIRE SIZE	CRIMP HEIGHT mm [INCH]	CRIMP HEIGHT REFERENCE SETTING
0.80mm2	1.02+/-0.05 [.040+/- .002]	5.9
18 AWG	1.02+/-0.05 [.040+/- .002]	5.9
0.50mm2	0.995+/-0.045 [.039+/- .0018]	6.2
20 AWG	0.995+/-0.045 [.039+/- .0018]	6.2

WIRE SIZE	CRIMP HEIGHT mm [INCH]	CRIMP HEIGHT REFERENCE SETTING
0.80mm2	1.02+/-0.05 [.040+/- .002]	5.9
18 AWG	1.02+/-0.05 [.040+/- .002]	5.9
0.50mm2	0.995+/-0.045 [.039+/- .0018]	6.2
20 AWG	0.995+/-0.045 [.039+/- .0018]	6.2
0.35mm2	0.895+/-0.045 [.035+/- .0018]	7.1
22 AWG	0.895+/-0.045 [.035+/- .0018]	7.1
0.20mm2	0.83+/-0.04 [.033+/- .0016]	7.7
24 AWG	0.83+/-0.04 [.033+/- .0016]	7.7

***WARNING**
ON INSTALLATION, SET WIRE DISC TO CRIMP HEIGHT REFERENCE SETTING FOR LARGEST WIRE SIZE. CRIMP HEIGHT REFERENCE SETTINGS GREATER THAN THE VALUE SHOWN MAY CAUSE DAMAGE TO THE CRIMP TOOLING, REFER TO THE INSTRUCTION SHEET FOR PROPER SETUP AND ADJUSTMENTS.

- RECOMMENDED SPARE PARTS
- REFER TO SUPPLIED INSTRUCTION SHEET FOR CLEANING, LUBRICATION AND STORAGE OF APPLICATOR.
- APPLY PART NUMBER 2-23419-6 LOCTITE TO THREADS OF ITEM 242.
- CRIMP HEIGHT REFERENCE SETTING WAS THE SETTING USED WHEN THE APPLICATOR WAS QUALIFIED AT THE FACTORY. ADJUSTMENT MAY BE NECESSARY WHEN RUNNING APPLICATOR IN THE FIELD.

5. UNLESS SPECIFIED OTHERWISE TORQUE VALUES SHALL BE USED PER DOCUMENT, 101-35000.

ATLANTIC VERSION
Shown on sheets 1 of 4 & 2 of 4
(Pacific version shown on sheets 3 of 4 & 4 of 4)

LOC	DIST	REVISIONS					
A	66	P	LTN	DESCRIPTION	DATE	OWN	APVD
		A		RELEASED	04NOV2011	LG	GB
		A1		ECR-15-018756	30DEC2015	JH	CT
		B		ECR-18-006525	03MAY2018	YY	JDG
		C		ECR-19-010789	10JUL2019	FJ	TE

-	1	-	1	-	2119641-1	FEED CAM, AIR FEED	248	
-	1	1	1	1	2119082-9	CAM, SNAIL, INSULATION ADJUSTMENT	244	
-	1	1	1	1	2079764-1	WASHER, WAVE SPRING, CREST-TO-CREST	243	
-	1	1	1	1	2119083-1	RETAINER, INSULATION DIAL	242	
-	1	1	1	1	18023-1	SCR, SKT HD CAP M3 X 5.0	241	
-	-	1	-	1	2119580-1	MECHANICAL FEED ASSEMBLY	239	
-	1	-	1	-	2844940-1	AIR FEED MODULE	238	
-	REF	REF	REF	REF	994970-2	COUNTER, MAGNETIC	164	
-	1	1	1	1	1-18028-2	WASHER, FLAT, REG M4	119	
-	1	1	1	1	2844908-1	SCREW, LOCKING	99	
-	1	1	1	1	2844907-1	POST, LOCKING	98	
-	1	1	1	1	455888-9	SPACER, CRIMPER	82	
-	1	1	1	1	1803607-3	DOCUMENTATION PACKAGE	71	
-	1	1	1	1	2119740-1	TAG, IDENTIFICATION	67	
-	2	2	2	2	2168078-1	SCREW, DRIVE, RH, RoHS, 2 x .188	66	
-	1	1	1	1	2168083-2	SCR, SKT HD CAP, RoHS, M4 X 8.0	60	
-	1	1	1	1	5-18022-5	SCR, HEX HD CAP, M4 X 6.0	59	
-	1	1	1	1	1338685-1	PAWL, FEED	56	
-	4	4	4	4	2168083-3	SCR, SKT HD CAP, RoHS, M4 X 12.0	54	
-	2	2	2	2	1-2168083-0	SCR, SKT HD CAP, RoHS, M4 X 10	53	
-	1	1	1	1	1803382-6	HOLD DOWN, SPRING LOADED	50	
-	1	2	1	2	18023-9	SCR, SKT HD CAP M4 X 6.0	49	
-	-	1	-	1	2119652-1	FEED CAM, PRE FEED	48	
-	-	1	-	1	2119653-1	FEED CAM, POST FEED	47	
-	1	1	1	1	1803583-9	APPLICATOR BASIC ASSEMBLY, SF	46	
-	1	1	1	1	1803515-1	RAM ASSEMBLY, SF ATLANTIC	44	
-	1	1	1	1	1803602-1	SCR, BHSC, RoHS (M8 X 25)	41	
-	1	1	1	1	1-1752356-9	SUPPORT, TERMINAL	34	
-	2	2	2	2	2079383-5	SCR, BHSC, RoHS (M4 X 20)	33	
-	2	2	2	2	2-2844962-4	SPACER, CYLINDRICAL, STRIP GUIDE	30	
-	1	1	1	1	2844992-1	ASSEMBLY, STRIP GUIDE	29	
-	1	1	1	1	1-455888-0	SPACER, CRIMPER	28	
-	1	1	1	1	1320928-2	STRIP GUIDE	24	
-	1	1	1	1	2168083-2	SCR, SKT HD CAP, RoHS, M4 X 8.0	21	
-	1	1	1	1	1-18028-2	WASHER, FLAT, REG M4	20	
-	1	1	1	1	2119533-1	STRIPPER, SIDE FEED	19	
-	1	1	1	1	2119806-1	INSERT, SHEAR	13	
-	1	1	1	1	3-22280-3	SPRING, COMPRESSION	12	
-	1	1	1	1	1-356885-4	STOP, SHEAR	11	
-	1	1	1	1	2119805-1	SHEAR HOLDER, FRONT	10	
-	1	1	1	1	1803095-1	FLOATING SHEAR, FRONT	9	
-	1	2	2	1	1	3-1633129-3	ANVIL, COMBINATION .062	8
-	1	1	1	1	2119757-4	DEPRESSOR, SHEAR	5	
-	1	1	1	1	1-238011-7	BLOCK, CRIMPER SPACER	4	
-	1	2	2	1	1	1-2119582-8	CRIMPER, INSULATION F PREMIUM	3
-	1	2	2	1	1	4-456403-2	CRIMPER, WIRE PREMIUM	1

DIMENSIONS:		TOLERANCES UNLESS OTHERWISE SPECIFIED:		MATERIAL:		FINISH:	
mm	0 PLC ±	1 PLC ±	2 PLC ±	3 PLC ±	4 PLC ±	ANGLES ±	

ITEM NO	PART NO	DESCRIPTION	ITEM NO				
-77	-72	-71	-2	-1	PART NO	DESCRIPTION	ITEM NO

OWN: STAKEM	11OCT2011	TE Connectivity Harrisburg, PA 17105-3608
CHK: G. BAILEY	11OCT2011	
APVD: T. ERLIN	11OCT2011	NAME: Ocean Side Feed Applicator
PRODUCT SPEC		SIZE: A1
APPLICATION SPEC		CAGE CODE: 00779
		DRAWING NO: C=2151015
WEIGHT		SCALE: 1:2
		SHEET: 1 OF 4
CUSTOMER ACCESSIBLE PRODUCTION DRAWING		REV: C

LOC		DIST		REVISIONS			
A	66	P	LYN	DESCRIPTION	DATE	DWN	APVD
		-		SEE SHEET 1			

FEED TYPE MECHANICAL

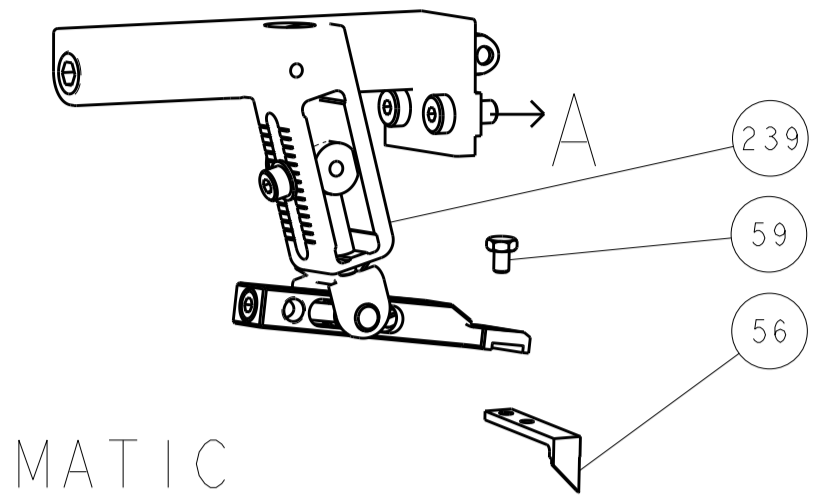

PNEUMATIC

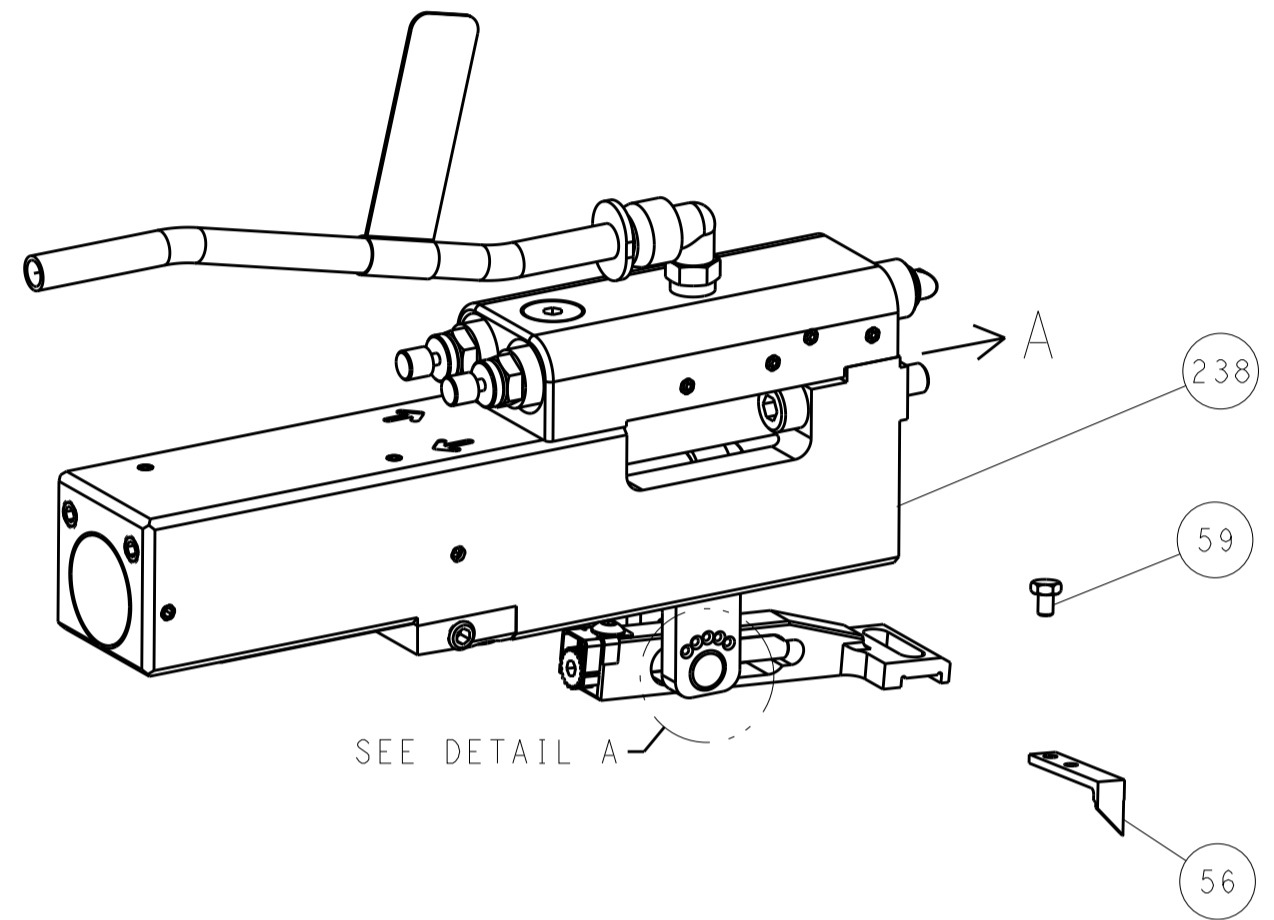

FEED SPRING SETTING POSITION (SHOWN FROM REAR SIDE)

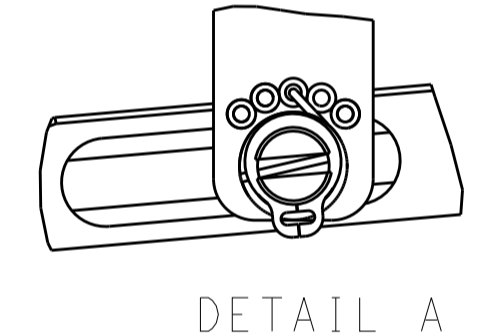

DETAIL A

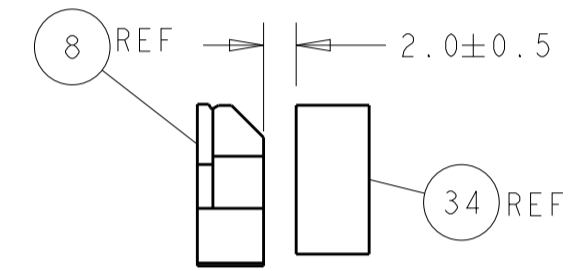
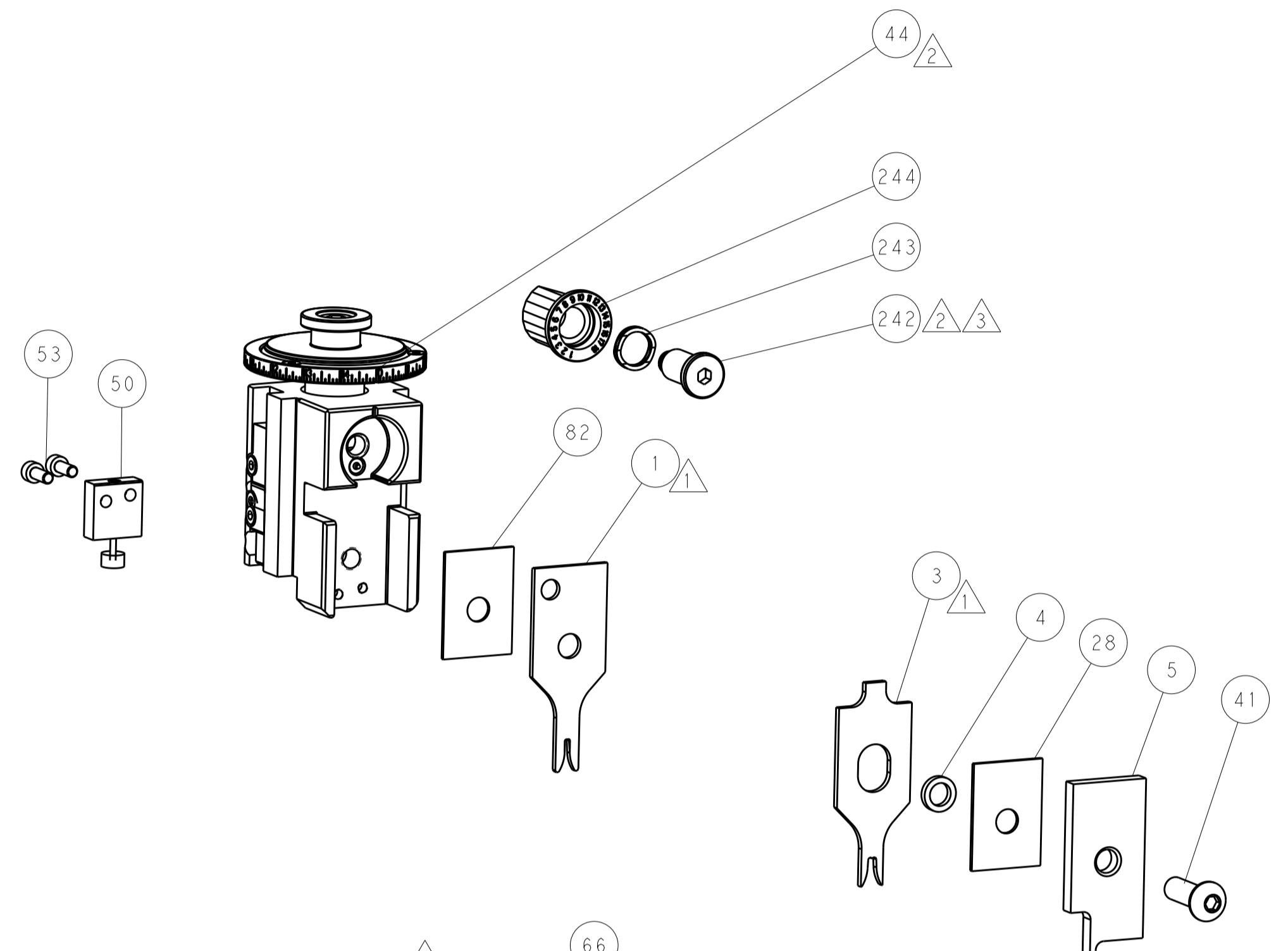

TERMINAL SUPPORT LOCATION

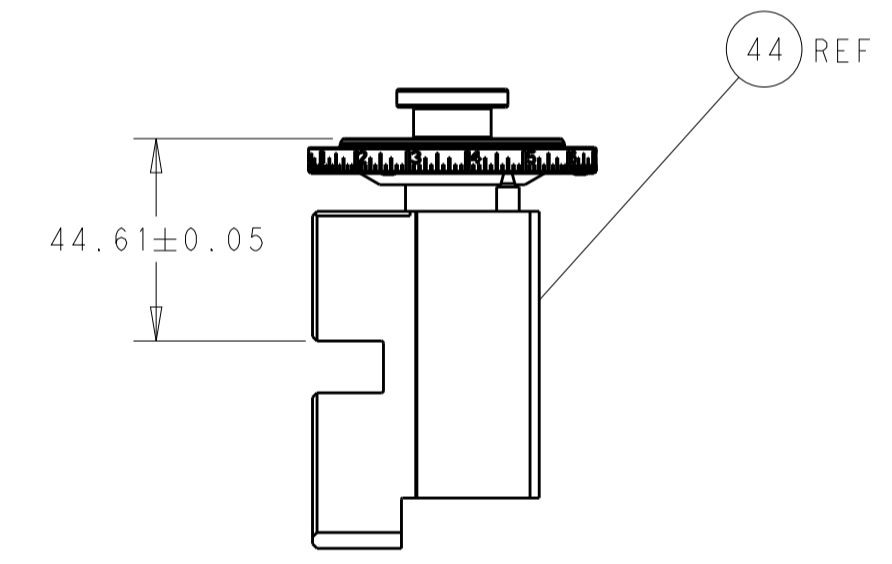

RAM SET-UP

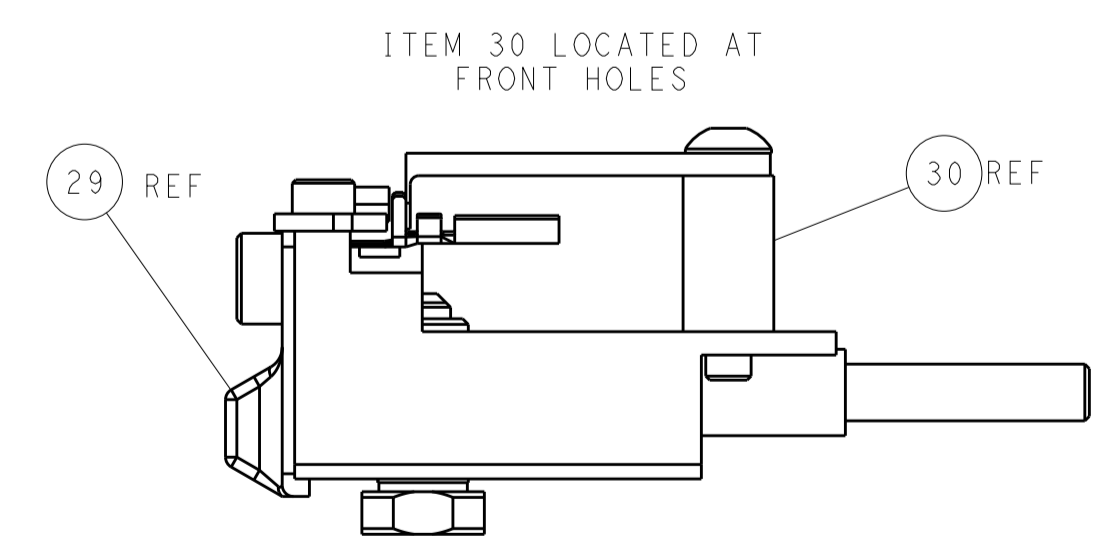
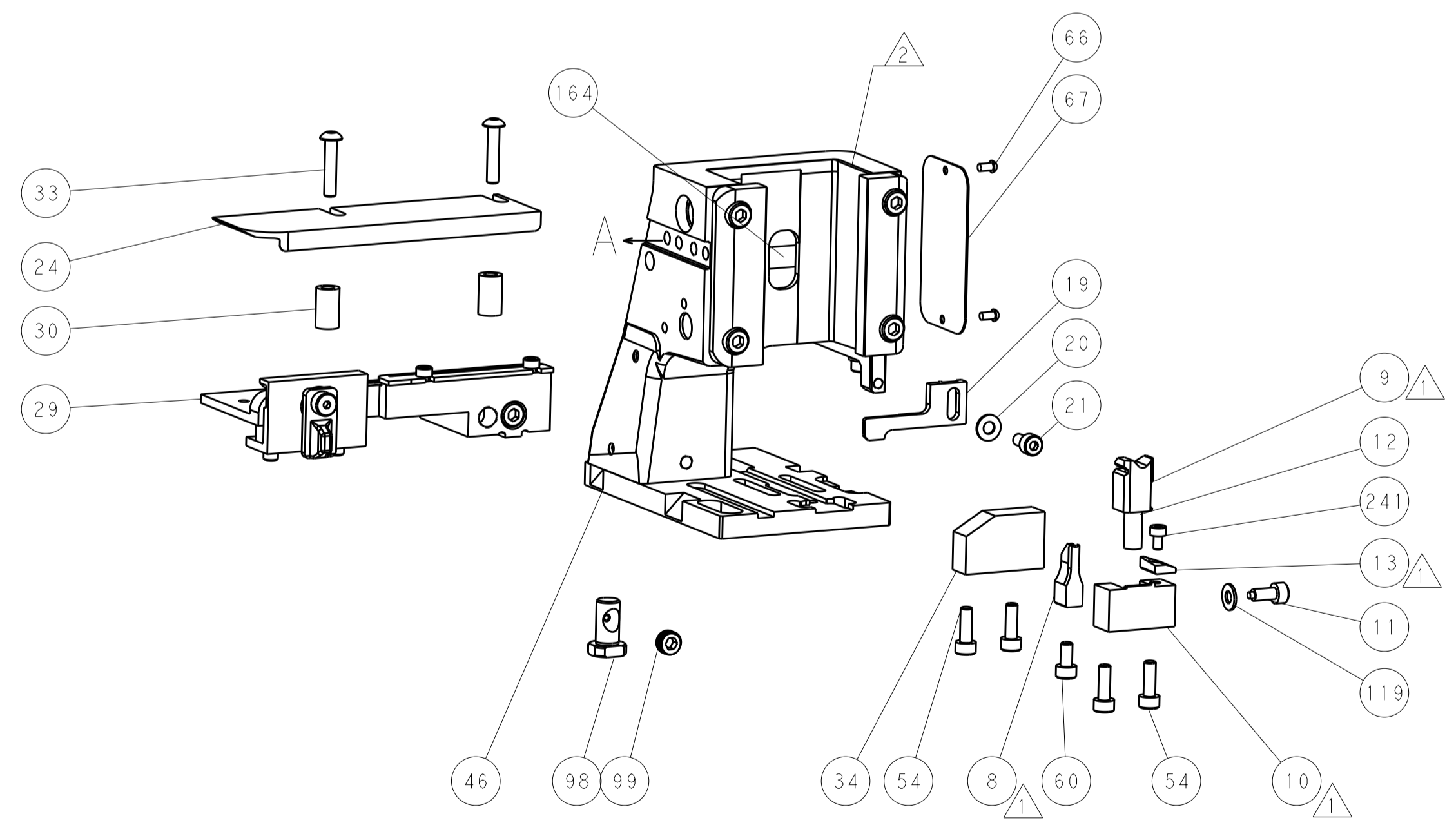

FEED TRACK POSITION GUIDE BY INSULATION BARREL

CAM POSITIONS

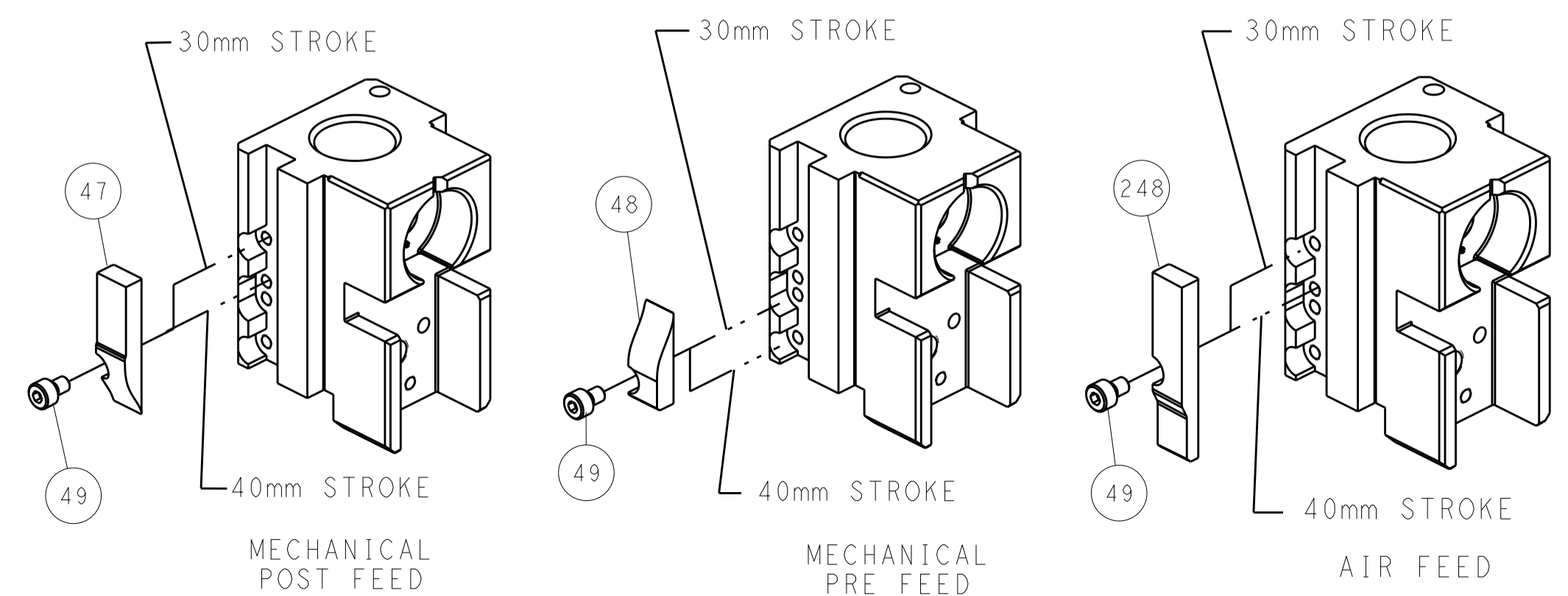

ATLANTIC VERSION
 Shown on sheets 1 of 4 & 2 of 4
 (Pacific version shown on sheets 3 of 4 & 4 of 4)

DIMENSIONS:		TOLERANCES UNLESS OTHERWISE SPECIFIED:		DWN: STAKEM 11OCT2011		TE Connectivity	
mm	0 PLC ±	1 PLC ±	2 PLC ±	3 PLC ±	4 PLC ±	Harrisburg, PA 17105-3608	
MATERIAL:		FINISH:		APVD: T. ELBIN 11OCT2011		NAME: Ocean Side Feed Applicator	
CUSTOMER ACCESSIBLE PRODUCTION DRAWING		SCALE: 1:2		SHEET 2 OF 4		REV C	

PART NUMBER	REVISION	DESCRIPTION	FEED TYPE
2-2151015-1	B	FINE CRIMP HEIGHT ADJUST	MECHANICAL
2-2151015-2	C	FINE CRIMP HEIGHT ADJUST	PNEUMATIC
7-2151015-7	A	CRIMP TOOLING KIT	-

PACIFIC VERSION TERMINATOR
INTERFACE ADAPTER

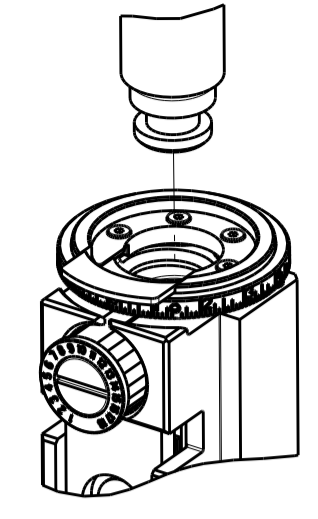

APPLICATOR DATA		
CRIMP	SIZE	TYPE
WIRE	1.58 mm [.062]	F
INSUL	3.18 mm [.125]	F

APPLICATOR INSTRUCTIONS
408-35042

TERMINAL DATA: MOLEX TERMINAL		MOLEX CRIMP SPECIFICATION	
TERMINAL NAME: 4.2mm PITCH MINI-FIT TERMINAL			
WIRE STRIP LENGTH		INSULATION DIAMETER RANGE	
3.00-3.50 mm [.118-.138 IN]		Ø 2.50-2.95 mm [.098-.116 IN]	
TERMINAL APPLICATION SPECIFICATION MOLEX 63900-2600 REV J			

TERMINALS APPLIED			
TE TERMINAL	MOLEX TERMINAL	TE TERMINAL	MOLEX TERMINAL
286603-1	39-00-0038	286611-1	39-00-0040
286603-2	39-00-0055	286611-2	39-00-0061
286603-3	39-00-0207	286611-3	39-00-0053
286603-4	39-00-0163	286611-4	39-00-0120
286603-5	39-00-0059	286611-5	39-00-0126
286603-6	39-00-0153	286611-6	39-00-0219
286603-7	39-00-0181	286611-8	39-00-0411
286603-8	39-00-0213	286611-9	39-00-0430
1-286603-0	44485-1211	1-286611-1	39-00-0121
1-286603-1	39-00-0114	1-286611-2	39-00-0420
1-286603-2	39-00-0428	1-286611-3	39-00-0437
1-286603-3	39-00-0419	1-286611-4	39-00-0426
1-286603-4	39-00-0425	1-286611-6	39-00-0075
1-286603-5	39-00-0436	1-286611-7	39-00-0427
1-286603-6	39-00-0440	1-286611-8	40-13-0853
1-286603-7	39-00-0073	2-286611-0	30490-1002
1-286603-8	39-00-0108	2-286611-1	30490-2002
1-286603-9	39-00-0169	2-286611-2	40-01-0853
2-286603-0	39-00-0175	2-286611-3	98-00-0174
2-286603-1	39-00-0194	2-286611-4	30490-0002
2-286603-2	39-00-0200		
2-286603-3	39-00-0405		
2-286603-4	39-00-0407		
2-286603-5	39-00-0410		
2-286603-6	40-13-0851		
2-286603-8	44485-1311		
2-286603-9	44485-1411		

TERMINAL DATA: MOLEX TERMINAL		CMOLEX CRIMP SPECIFICATION	
TERMINAL NAME: 4.2mm PITCH MINI-FIT TERMINAL			
WIRE STRIP LENGTH		INSULATION DIAMETER RANGE	
3.00-3.50 mm [.118-.138 IN]		Ø 2.50-2.95 mm [.098-.116 IN]	
TERMINAL APPLICATION SPECIFICATION MOLEX 63900-2600 REV J			

TERMINALS APPLIED			
TE TERMINAL	MOLEX TERMINAL	TE TERMINAL	MOLEX TERMINAL
286603-9	44476-1111	1-2113022-1	46083-1211
2-286603-7	44476-1211	1-2113022-2	46083-1221
286611-7	44478-1111	1-2113022-3	46134-1111
1-286611-9	44478-1211	1-2113022-4	46134-1121
2113022-1	45750-1211	1-2113022-5	46134-1211
2113022-2	45750-1111	1-2113022-6	46134-1221
2113022-3	46012-1111		
2113022-4	46018-1541		
2113022-5	46083-1111		
2113022-6	46098-1541		
2113022-7	46012-1141		
2113022-8	46012-1211		
2113022-9	46012-1241		
1-2113022-0	46083-1121		

WIRE SIZE	CRIMP HEIGHT mm [INCH]	CRIMP HEIGHT REFERENCE SETTING
0.80mm2	1.02+/-0.05 [.040+/- .002]	5.9
18 AWG	1.02+/-0.05 [.040+/- .002]	5.9
0.50mm2	0.995+/-0.045 [.039+/- .0018]	6.2
20 AWG	0.995+/-0.045 [.039+/- .0018]	6.2

WIRE SIZE	CRIMP HEIGHT mm [INCH]	CRIMP HEIGHT REFERENCE SETTING
0.80mm2	1.02+/-0.05 [.040+/- .002]	5.9
18 AWG	1.02+/-0.05 [.040+/- .002]	5.9
0.50mm2	0.995+/-0.045 [.039+/- .0018]	6.2
20 AWG	0.995+/-0.045 [.039+/- .0018]	6.2
0.35mm2	0.895+/-0.045 [.035+/- .0018]	7.1
22 AWG	0.895+/-0.045 [.035+/- .0018]	7.1
0.20mm2	0.83+/-0.04 [.033+/- .0016]	7.7
24 AWG	0.83+/-0.04 [.033+/- .0016]	7.7

*WARNING
ON INSTALLATION, SET WIRE DISC TO CRIMP HEIGHT REFERENCE SETTING FOR LARGEST WIRE SIZE. CRIMP HEIGHT REFERENCE SETTINGS GREATER THAN THE VALUE SHOWN MAY CAUSE DAMAGE TO THE CRIMP TOOLING, REFER TO THE INSTRUCTION SHEET FOR PROPER SETUP AND ADJUSTMENTS.

- 1 RECOMMENDED SPARE PARTS
 - 2 REFER TO SUPPLIED INSTRUCTION SHEET FOR CLEANING, LUBRICATION AND STORAGE OF APPLICATOR.
 - 3 APPLY PART NUMBER 2-23419-6 LOCTITE TO THREADS OF ITEM 242.
 - 4 CRIMP HEIGHT REFERENCE SETTING WAS THE SETTING USED WHEN THE APPLICATOR WAS QUALIFIED AT THE FACTORY. ADJUSTMENT MAY BE NECESSARY WHEN RUNNING APPLICATOR IN THE FIELD.
5. UNLESS SPECIFIED OTHERWISE TORQUE VALUES SHALL BE USED PER DOCUMENT, 101-35000.

PACIFIC VERSION
Shown on sheets 3 of 4 & 4 of 4
(Atlantic version shown on sheets 1 of 4 & 2 of 4)

LOC	DIST	REVISIONS					
A	66	P	LTN	DESCRIPTION	DATE	OWN	APVD
		-		SEE SHEET 1			

-	1	1	2119082-9	CAM, SNAIL, INSULATION ADJUSTMENT	244
-	1	1	2079764-1	WASHER, WAVE SPRING, CREST-TO-CREST	243
-	1	1	2119083-1	RETAINER, INSULATION DIAL	242
-	1	1	18023-1	SCR, SKT HD CAP M3 X 5.0	241
-	-	1	2119580-1	MECHANICAL FEED ASSEMBLY	239
-	1	-	2844940-1	AIR FEED MODULE	238
-	REF	REF	994970-2	COUNTER, MAGNETIC	164
-	1	-	2119641-2	FEED CAM, AIR FEED	151
-	1	1	2168083-8	SCR, SKT HD CAP, RoHS, M4 X 16	144
-	4	4	2168083-9	SCR, SKT HD CAP, RoHS, M4 X 20	143
-	-	1	2119653-2	FEED CAM, POST FEED	142
-	1	1	1-1803583-0	APPLICATOR BASIC ASSEMBLY, SF	141
-	1	1	1803516-1	RAM ASSEMBLY, SF PACIFIC	140
-	1	1	1-18028-2	WASHER, FLAT, REG M4	119
-	1	1	2844908-1	SCREW, LOCKING	99
-	1	1	2844907-1	POST, LOCKING	98
-	1	1	455888-9	SPACER, CRIMPER	82
-	1	1	1803607-3	DOCUMENTATION PACKAGE	71
-	1	1	2119740-1	TAG, IDENTIFICATION	67
-	2	2	2168078-1	SCREW, DRIVE, RH, RoHS, 2 x .188	66
-	1	1	5-18022-5	SCR, HEX HD CAP, M4 X 6.0	59
-	1	1	1338685-1	PAWL, FEED	56
-	2	2	1-2168083-0	SCR, SKT HD CAP, RoHS, M4 X 10	53
-	1	1	1803382-6	HOLD DOWN, SPRING LOADED	50
-	1	2	18023-9	SCR, SKT HD CAP M4 X 6.0	49
-	-	1	2119652-1	FEED CAM, PRE FEED	48
-	1	1	1803602-1	SCR, BHSC, RoHS (M8 X 25)	41
-	1	1	1-1752356-9	SUPPORT, TERMINAL	34
-	2	2	2079383-5	SCR, BHSC, RoHS (M4 X 20)	33
-	2	2	2-2844962-4	SPACER, CYLINDRICAL, STRIP GUIDE	30
-	1	1	2844992-1	ASSEMBLY, STRIP GUIDE	29
-	1	1	1-455888-0	SPACER, CRIMPER	28
-	1	1	1320928-2	STRIP GUIDE	24
-	1	1	2168083-2	SCR, SKT HD CAP, RoHS, M4 X 8.0	21
-	1	1	1-18028-2	WASHER, FLAT, REG M4	20
-	1	1	2119533-1	STRIPPER, SIDE FEED	19
-	1	1	2119806-1	INSERT, SHEAR	13
-	1	1	3-22280-3	SPRING, COMPRESSION	12
-	1	1	1-356885-4	STOP, SHEAR	11
-	1	1	2119805-1	SHEAR HOLDER, FRONT	10
-	1	1	1803095-1	FLOATING SHEAR, FRONT	9
1	1	1	3-1633129-3	ANVIL, COMBINATION .062	8
-	1	1	2119757-4	DEPRESSOR, SHEAR	5
-	1	1	1-238011-7	BLOCK, CRIMPER SPACER	4
1	1	1	1-2119582-8	CRIMPER, INSULATION F PREMIUM	3
1	1	1	4-456403-2	CRIMPER, WIRE PREMIUM	1

DIMENSIONS:		TOLERANCES UNLESS OTHERWISE SPECIFIED:		MATERIAL:		FINISH:		WEIGHT:		SCALE:		SHEET:		REV:	
mm	0 PLC ±	1 PLC ±	2 PLC ±	3 PLC ±	4 PLC ±	ANGLES ±					1:2	3	4		C

LOC		DIST		REVISIONS			
P	LTN	DESCRIPTION	DATE	DWN	APVD		
A	66	SEE SHEET 1					

FEED TYPE MECHANICAL

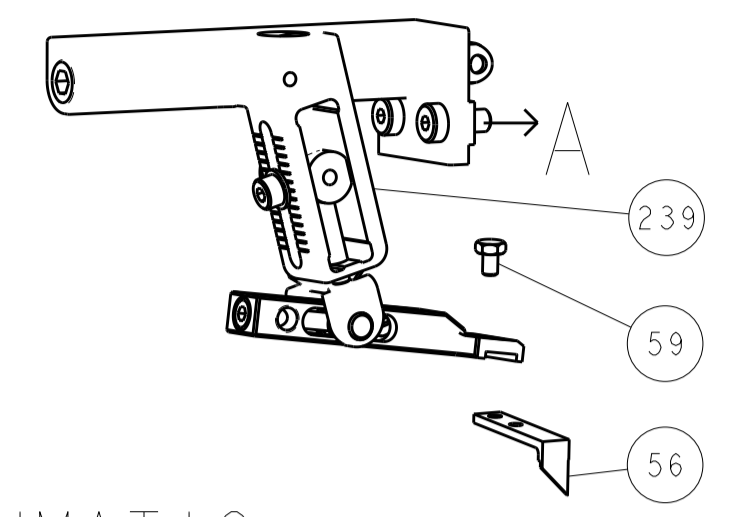

PNEUMATIC

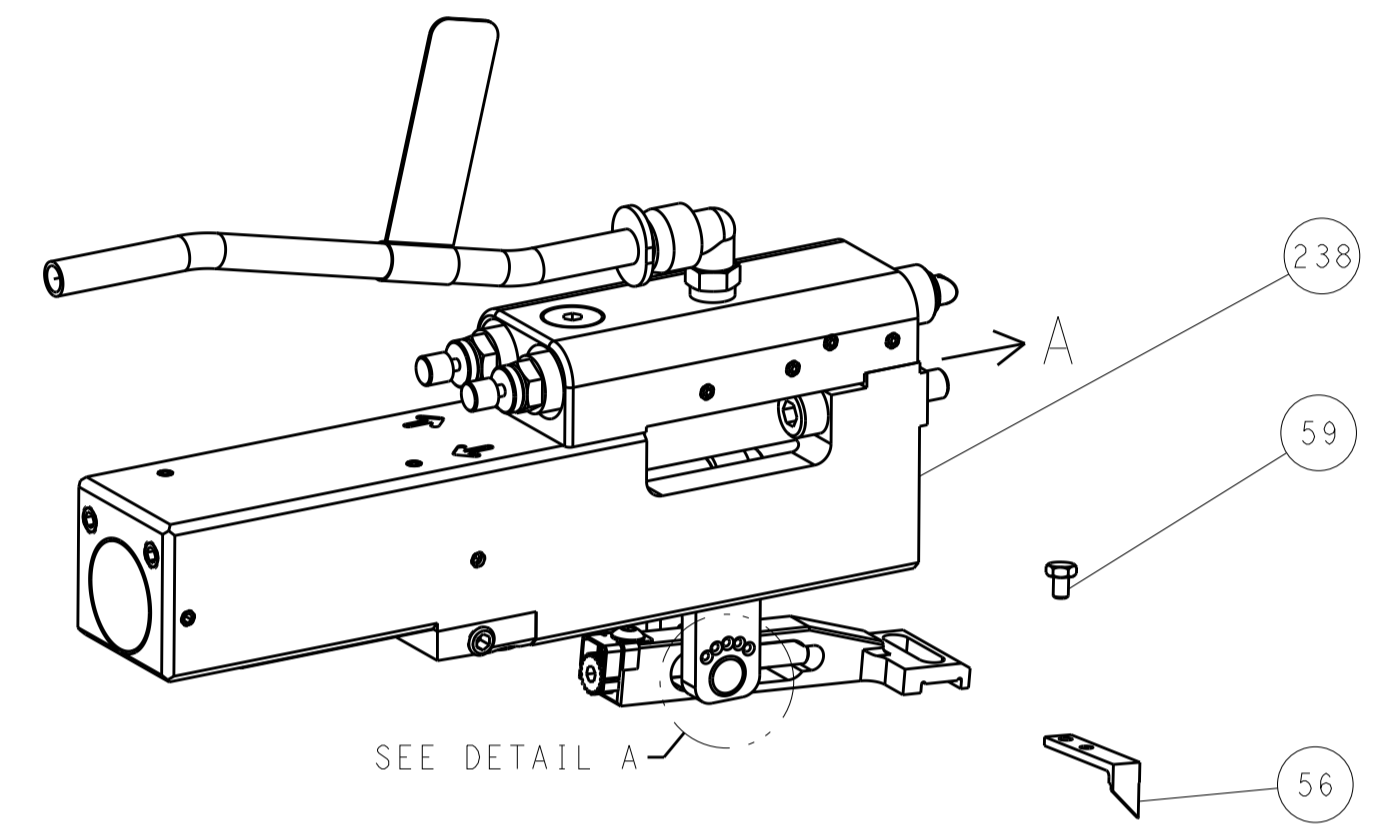

FEED SPRING SETTING POSITION (SHOWN FROM REAR SIDE)

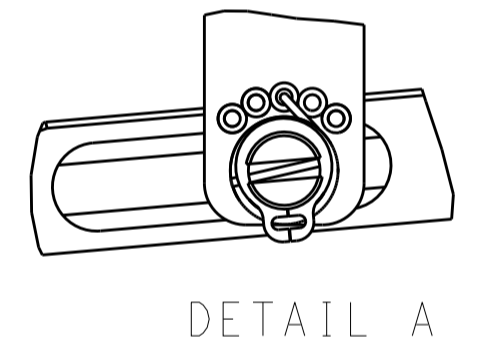

CAM POSITIONS

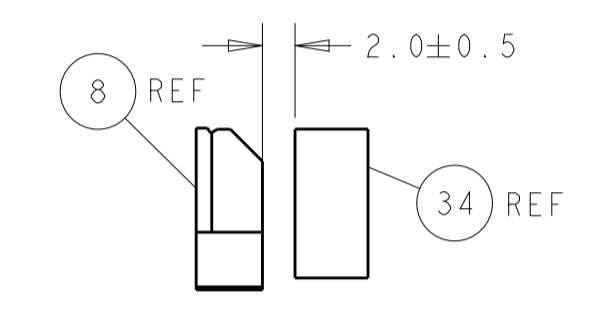
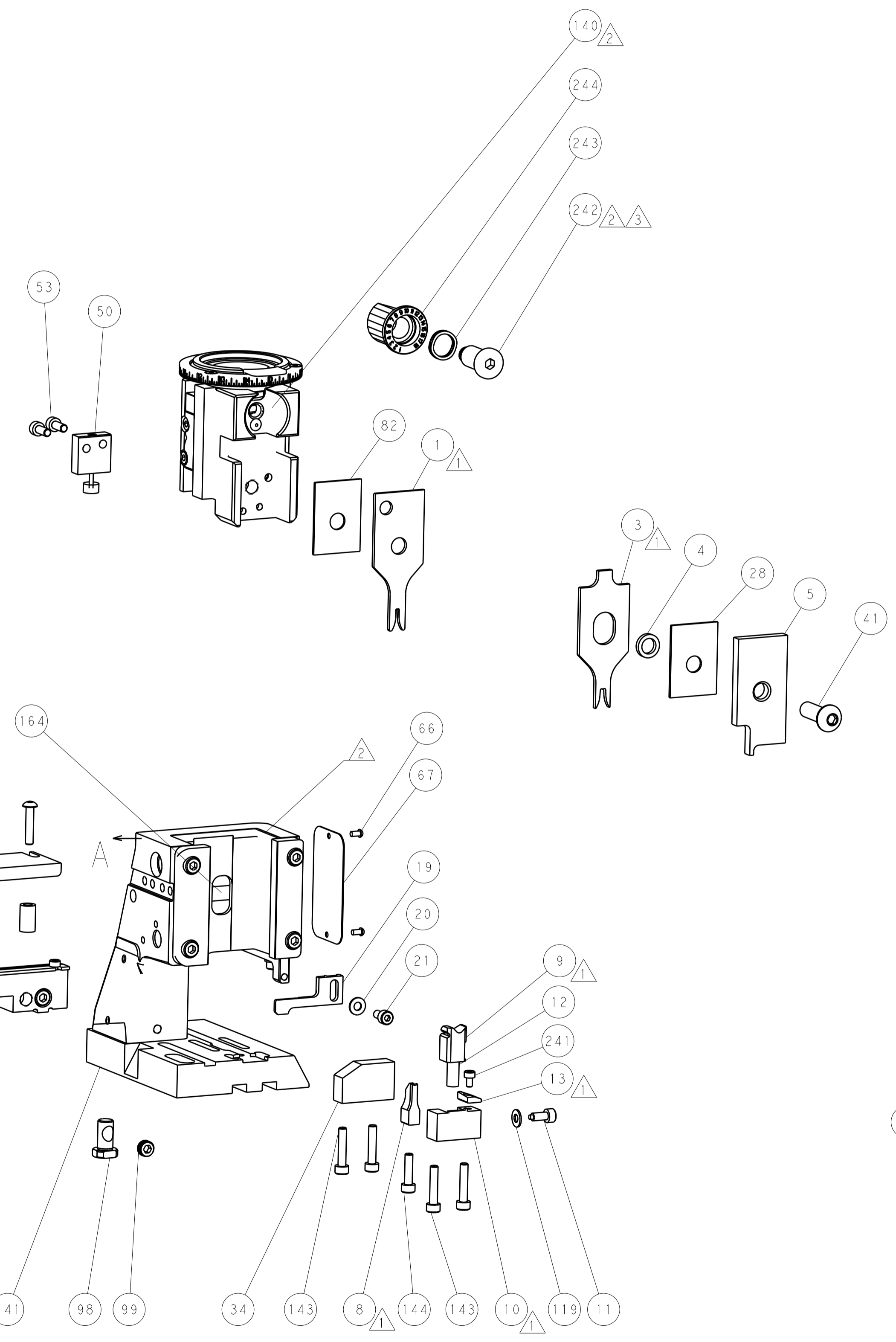

TERMINAL SUPPORT LOCATION

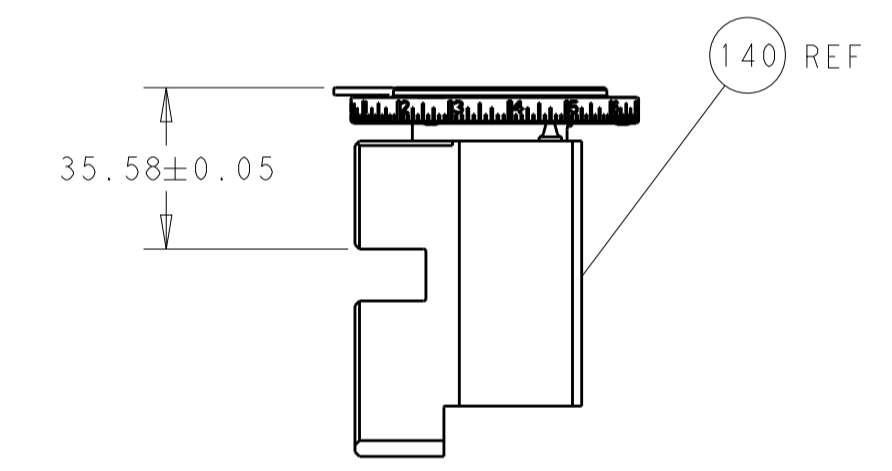

RAM SET-UP

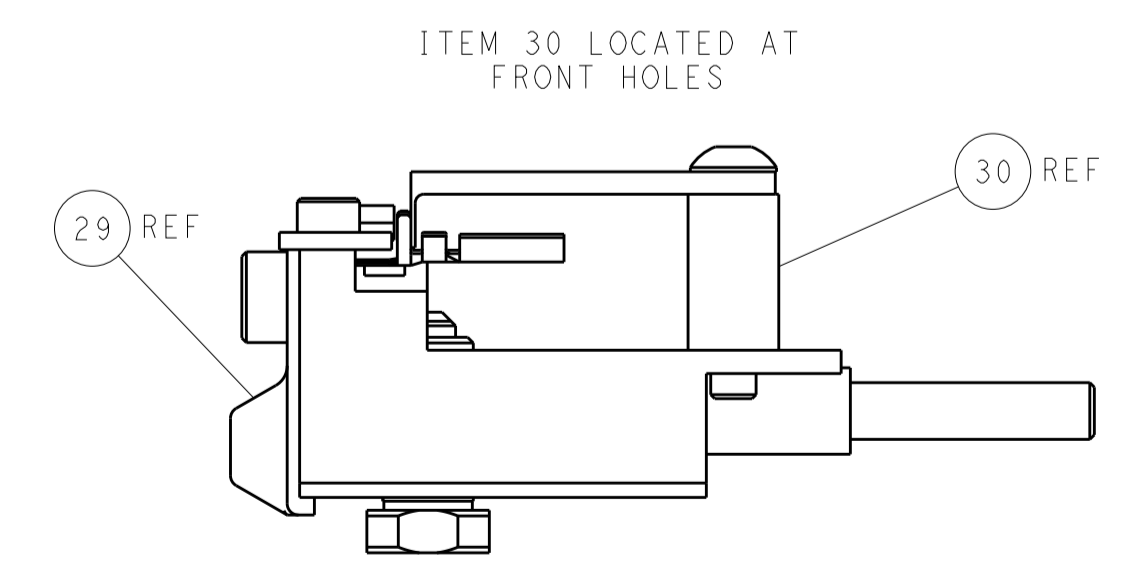

FEED TRACK POSITION GUIDE BY INSULATION BARREL

PACIFIC VERSION
 Shown on sheets 3 of 4 & 4 of 4
 (Atlantic version shown on sheets 1 of 4 & 2 of 4)

DIMENSIONS:		TOLERANCES UNLESS OTHERWISE SPECIFIED:		DWN: STAKEM 11OCT2011		TE Connectivity	
mm	0 PLC ±	1 PLC ±	2 PLC ±	3 PLC ±	4 PLC ±	5 PLC ±	Harrisburg, PA 17105-3608
	ANGLES	FINISH		CHK: G. BAILEY 11OCT2011	NAME: Ocean Side Feed Applicator		
MATERIAL:				APVD: T. ERLIN 11OCT2011	SIZE: CAGE CODE: DRAWING NO: RESTRICTED TO		
				PRODUCT SPEC:		A 00779 ©=2151015	
				APPLICATION SPEC:		SCALE: 1:2 SHEET 4 OF 4 REV C	
				WEIGHT:		CUSTOMER ACCESSIBLE PRODUCTION DRAWING	