

Single Output General Purpose Power Supplies

Features

- ◆ Low Cost
- ◆ Power Factor Correction to EN61000-3-2
- ◆ Universal Input (85 - 265VAC)
- ◆ Input Transient Protected IEC61000-4
- ◆ Enclosed
- ◆ Global safety Approvals
- ◆ Level B EMI



Key Market Segments & Applications



Specifications		SWS50	SWS75	SWS100	SWS150
Input Voltage range (1)	-	85 - 265VAC (47 - 63Hz) or 120 - 370VDC*			
Inrush Current (115/230VAC)	A	20/40		16/32	
Power Factor	-	Meets EN61000-3-2			
Input Current (115/230VAC)	A	1.2/0.6	1.6/0.8	1.2/0.6	1.8/0.9
Temperature Coefficient	-	<0.02%/°C			
Total Regulation	-	<5%			
Overcurrent Protection	-	>105%, Constant Current Style			
Overvoltage Protection	V	115 -135%, Cycle AC line to reset			
Hold Up Time (Typ)	ms	20ms at 115VAC			
Leakage Current Max.	mA	1mA (0.6mA typ@230VAC)		0.75mA (0.5mA typ@230VAC)	
Remote Sense	-	Not Available			
LED Indicator	-	Green LED = On			
Operating Temperature	-	-10 to +70°C (See table for derating - model specific)			
Storage Temperature	-	-30 to +85°C			
Operating Humidity (2)	°C	30 - 90% RH			
Storage Humidity (2)	°C	10 - 95% RH			
Cooling	-	Convection			
Withstand Voltage	-	Input to Ground 2kVAC, Input to Output 3kVAC, Output to Ground 500VAC for 1 min.			
Isolation Resistance	-	>100M at 25°C & 70%RH, Output to Ground 500VDC			
Vibration (non operating)	-	19.6m/s ² (10 - 55Hz (constant sweep 1 min) X, Y, Z for 1 hour)			
Shock	-	< 196.1 m/s ² (20G)			
Safety Agency Approvals	-	UL60950-1, CSA60950-1, EN60950-1, CE Mark, EN50178			
Conducted & Radiated EMI	-	EN55011 / EN55022-B, FCC Class B, VCCI-B			
Recommended EMI Filter	-	RSEL-2002W	RSEL-2003W	RSEL-2002W	RSEL-2003W
Immunity	-	EN61000-4-2,-3,-4,-5,-6,-8,-11			
Weight (Typ)	g	400	480	600	750
Size (WxHxD)	in	3.62 x 1.46 x 6.26	3.7 x 1.69 x 6.69	3.78 x 1.77 x 7.4	3.9 x 2 x 7.8
Warranty	yrs	Two Years			

(1) Derate to 85% load below 100VAC input (2) non condensing

*Safety certified for AC input only

OBSOLETE

Model Selector							
Model	Voltage	Adjust Range	Max Curr.	Load Reg mV	Line Reg mV	Ripple Noise	Eff. (typ)%
SWS50-3	3.3V	3-3.6V	10	40	20	80	73/70
SWS75-3	3.3V	3-3.6V	15	40	20	80	72/68
SWS100-3	3.3V	3-3.6V	20	40	20	100	69/70
SWS150-3	3.3V	3-3.6V	30	40	20	100	70/72
SWS50-5	5V	4.5-5.5V	10	50	20	80	77/75
SWS75-5	5V	4.5-5.5V	15	50	20	80	77/74
SWS100-5	5V	4.5-5.5V	20	40	20	100	75/77
SWS150-5	5V	4.5-5.5V	30	40	20	100	76/78
SWS50-12	12V	10.8-13.2V	4.3	96	48	80	82/79
SWS75-12	12V	10.8-13.2V	6.3	96	48	80	83/81
SWS100-12	12V	10.8-13.2V	8.5	96	48	100	79/81
SWS150-12	12V	10.8-13.2V	12.5	96	48	100	79/82
SWS50-15	15V	13.5-16.5V	3.5	120	60	100	84/80
SWS75-15	15V	13.5-16.5V	5	120	60	100	85/82
SWS100-15	15V	13.5-16.5V	6.7	120	60	100	81/83
SWS150-15	15V	13.5-16.5V	10	120	60	100	81/83
SWS150-18	18V	16.2-19.8V	8.4	144	72	120	82/84
SWS50-24	24V	21.6-26.4V	2.1	144	96	100	84/80
SWS75-24	24V	21.6-26.4V	3.2	144	96	100	85/82
SWS100-24	24V	21.6-26.4V	4.3	144	96	150	82/84
SWS150-24	24V	21.6-26.4V	6.3	144	96	150	82/85

Vertical Mount Convection	25°C	30°C	35°C	40°C	45°C	50°C	55°C	60°C
SWS50	100%	100%	100%	100%	100%	100%	93%	85%
SWS75 (3.3-5V)	100%	100%	100%	100%	93%	85%	73%	60%
SWS75 (12V-24V)	100%	100%	100%	100%	100%	93%	85%	60%
SWS100	100%	100%	100%	100%	100%	87%	73%	60%
SWS150 (3.3-5V)	100%	95%	90%	85%	73%	60%	-	-
SWS150 (12V-24V)	100%	100%	100%	100%	100%	100%	80%	60%

1.2m/s Forced Air	50°C	55°C	60°C	65°C	70°C
SWS75	100%	100%	90%	80%	70%
SWS100	100%	100%	90%	80%	70%
SWS150	100%	100%	90%	80%	70%

Derate to 80% load from 0 to -10°C

Other Industrial Products	
HWS	15W to 1500W Single Output
LS	25W to 200W Low Cost
SWS300/600/1000	300W to 1000W (Higher Power)

Options	
Suffix	Descriptor
/CO2	Double sided conformal coating

For Additional Information, please visit us.tdk-lambda.com/lp/products/sws-series.htm



SWS50 Outline Drawing

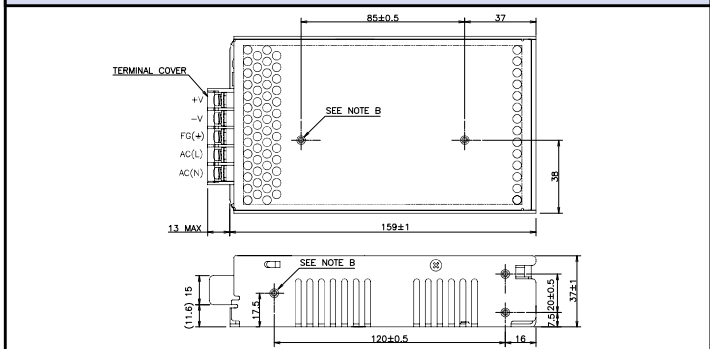

SWS75 Outline Drawing

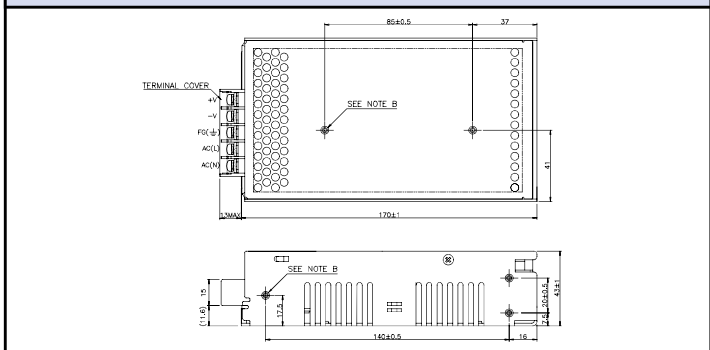

SWS100 Outline Drawing

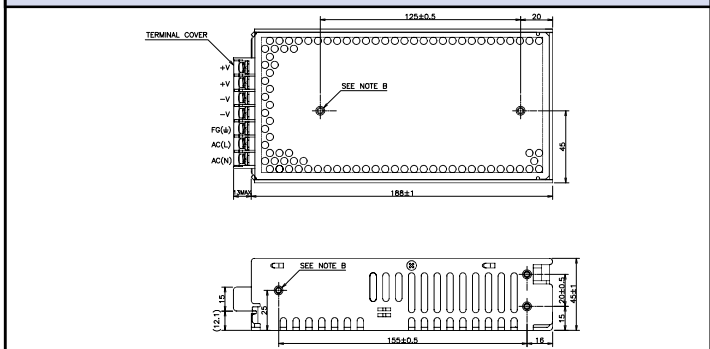

SWS150 Outline Drawing

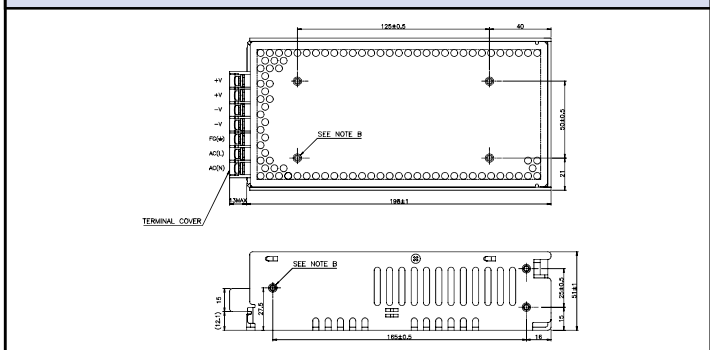

OBSOLETE