



Industrial



Comm



Renewable



Automation

## 300 and 600W Constant Current Power Supplies

Features	Benefits
• 300W Convection cooled and 600W fan model	• Silent fanless chargers
• CC (constant current) mode	• Quick recharge, avoid battery overcharging
• CV (constant voltage) mode	• Supports charging of 12, 24 and 48V batteries
• 5 Year warranty	• Provides high reliability for battery charger and electrical storage system



Specification		EVS300	EVS600
Input Voltage	V	85-265VAC (47-63Hz)	85-265VAC (47-63Hz)
Input Current	A	3.6 / 1.8	7.2 / 4.0
Inrush Current (100/200VAC)	A	15 / 30	20 / 40
Power Factor (100/200VAC)	-	0.97/0.93	0.95/0.9
PFHC	-	Meets EN61000-3-2	
Leakage Current	mA	< 0.5mA	< 0.75mA
Temperature Coefficient	%/°C	<0.02%/°C	
Constant Current Setting Accuracy	A	±10%	
Overvoltage Protection	V	18V*: 19.8-23.4V, 36V: 39.6-46.8V, 57V: 62.7-74.1V (* EVS300 only)	
Hold Up Time (Typ)	ms	10ms at 100/110VAC input	
Efficiency (100/200VAC)	%	18V: 86/89%, 36V: 88/91%, 57V: 87/90%	36V: 85/88%, 57V: 84/87%
Remote On/Off	-	Optional	
Series & Parallel Operation	-	Yes, see instruction manual	
Operating Temperature (No external airflow)	°C	-20°C to +70°C Derate linearly to 40% load from 45°C to 70°C	-20°C to +70°C Derate linearly to 20% load from 50°C to 70°C
Operating Temperature External airflow (1.4m/s)	°C	-20°C to +70°C Derate linearly to 70% load from 60°C to 70°C	-20°C to +70°C Not applicable (EVS600 has internal fan)
Storage Temperature	°C	-30°C to +75°C	
Humidity (non condensing)	%RH	Operating: 30 - 90%RH, Storage: 10 - 90%RH	
Cooling	-	Convection or forced air	Internal fan
Withstand Voltage	VAC	Input to Ground 2kVAC, Input to Output 3kVAC, Output to Ground 500VAC for 1 min.	
Isolation Resistance	MΩ	>100MΩ at 25°C & 70%RH, Output to Ground 500VDC	
Vibration (non operating)	-	10 - 55Hz (1 minute sweep), 19.6m/s <sup>2</sup> constant, X, Y, Z 1 hour each	
Shock	-	< 196.1 m/s <sup>2</sup>	
Safety Agency Certifications	-	UL60950-1, CSA60950-1, EN60950-1, CE Mark	
Conducted & Radiated EMI	-	EN55011/EN55022-B, FCC Class B, VCCI-B	
Immunity	-	EN61000-4-2, -3, -4, -5, -6, -8, -11; EN61000-6-2	
Weight (Typ)	g	540g (open frame)	1600g
Size (WxHxD)	mm	84 x 42 x 180mm	120 x 61 x 190mm
Warranty	yrs	5	

## Model Selector

Model	Nominal Voltage Output	Adjust Range (V)	Max Current (100VAC)	Max Current (200VAC)	Current Adjust Range (100VAC)	Current Adjust Range (200VAC)	CV Line Reg (mV)	CV Load Reg (mV)	Ripple & Noise (mV)
EVS18-16R7	18V	12 - 18V	16.7A		8.35 - 16.70A		72	144	200
EVS36-8R4	36V	24 - 36V	8.4A		4.20 - 8.40A		144	252	250
EVS36-16R7	36V	24 - 36V	15.3A	16.7A	8.35 - 15.30A	8.35 - 16.70A	144	288	200
EVS57-5R3	57V	48 - 57V	5.3A		2.65 - 5.30A		228	285	250
EVS57-10R6	57V	48 - 57V	9.7A	10.6A	5.30 - 9.70A	5.30 - 10.60A	228	456	200

## Outline Drawing EVS300W Series

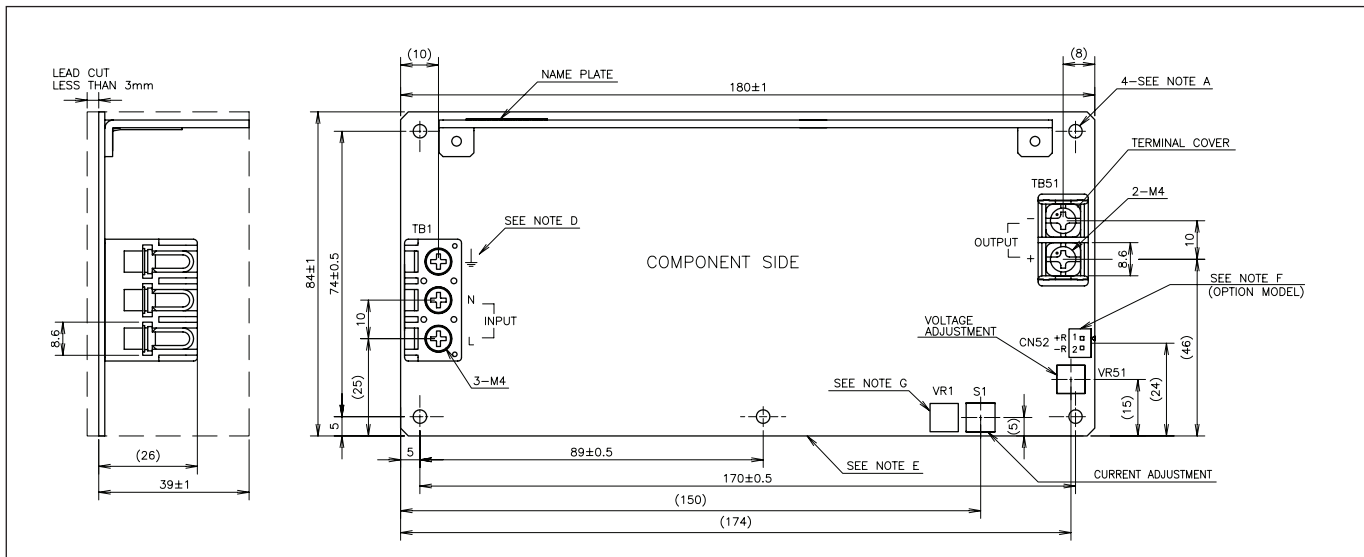

## Options

Suffix	Description
-	None
/A	Cover & L Bracket (Standard on EVS600) *
/R	Remote On/Off
Example	EVS57-5R3/RA

Note: \* without suffix

## Outline Drawing EVS600W Series

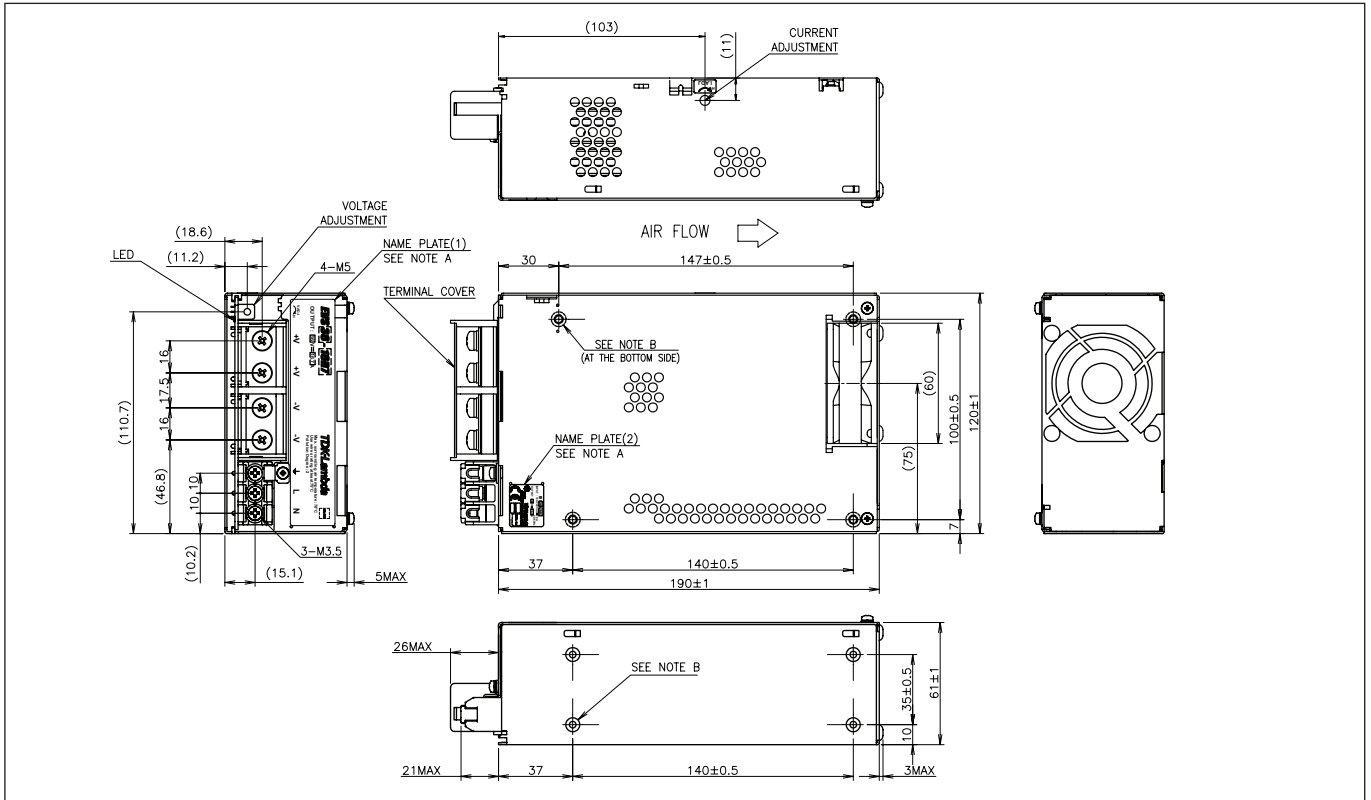

### Accessory

Model	Description
RP-60-20	20A Reverse current Prevention module for battery charging use (PCB type) *
RP-60-20/L	20A Reverse current Prevention module for battery charging use (on L bracket) *

\* The Reverse current Protection modules RP can also be used as replacement for Diode-modules (as e.g. DLP-PU)

- For power up in parallel operation
- For Back-up diode (N + I redundant operation)

(Note: as from April 1st 2018 the EVS-RP6020 has been renamed RP-60-20)

## Outline Drawing RP-60-20 (Open frame)

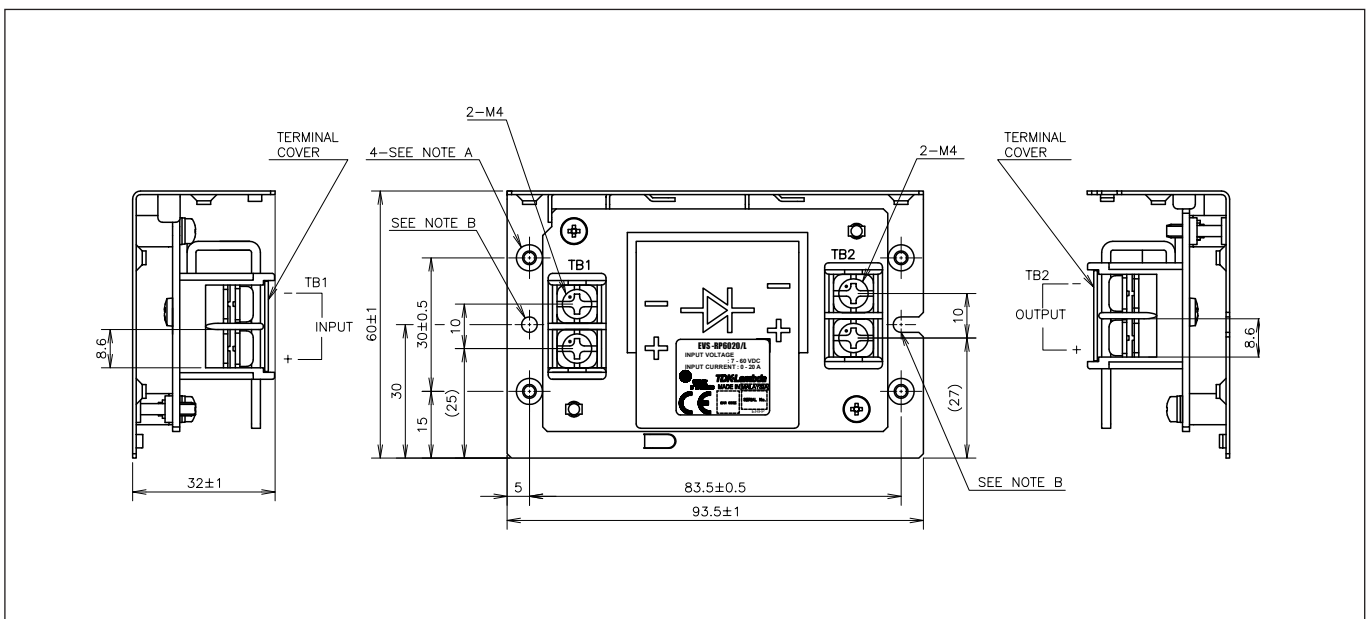

## Outline Drawing RP-60-20/L Series

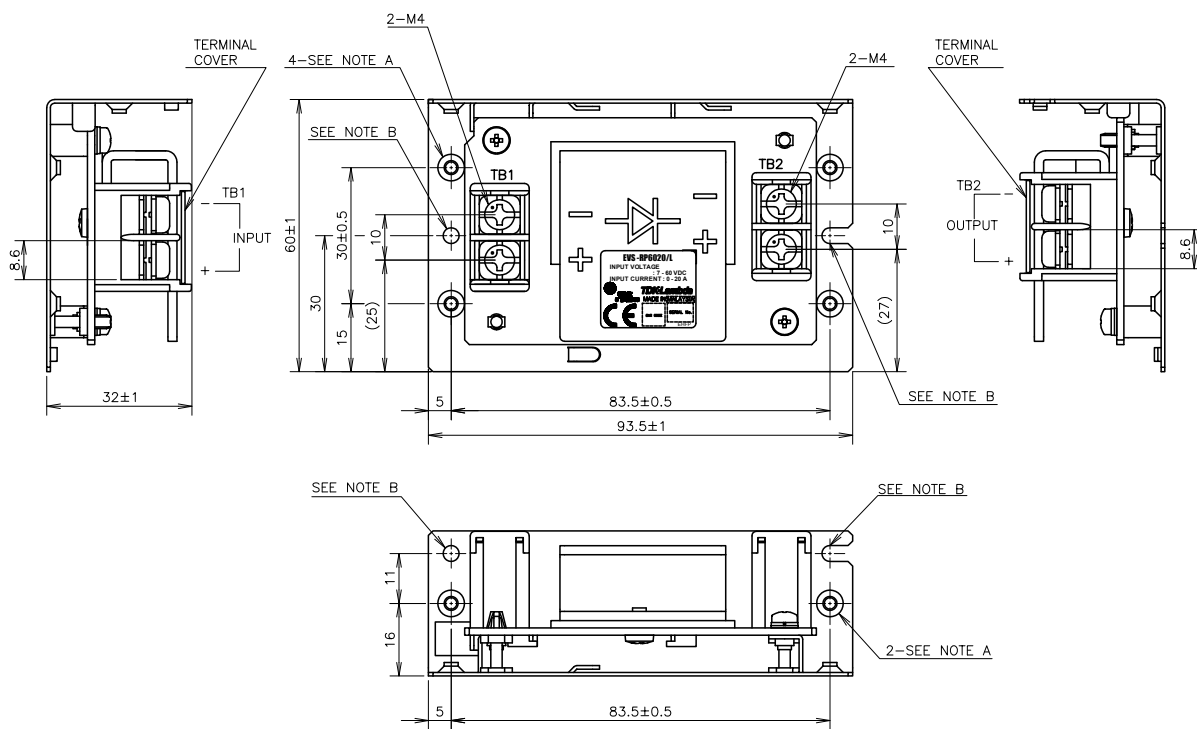

### Notes:

- A: M3 embossed tapped and countersink holes (6) are for customer's chassis mounting
- B: Dia 3.5mm holes (2) and R1.75 slot holes (2) are for customer's chassis mounting holes
- C: Model name, input range and input current are shown here in accordance with the specifications
- D: Country of manufacture will be shown here

### Accessories:

- \* Terminal cover for barrier terminal strip —2 (attached on terminal TB1 and TB2 at shipment)



## TDK-Lambda France SAS

3 Avenue du Canada  
Parc Technopolis  
Bâtiment Sigma  
91940 les Ulis  
France  
Tel: +33 1 60 12 71 65  
Fax: +33 1 60 12 71 66  
france@fr.tdk-lambda.com  
www.fr.tdk-lambda.com



## Italy Sales Office

Via dei Lavoratori 128/130  
20092 Cinisello Balsamo (MI)  
Italy  
Tel: +39 02 61 29 38 63  
Fax: +39 02 61 29 09 00  
info.italia@it.tdk-lambda.com  
www.it.tdk-lambda.com



## Netherlands

info@nl.tdk-lambda.com  
www.nl.tdk-lambda.com



## TDK-Lambda Germany GmbH

Karl-Bold-Strasse 40  
77855 Achern  
Germany  
Tel: +49 7841 666 0  
Fax: +49 7841 5000  
info.germany@de.tdk-lambda.com  
www.de.tdk-lambda.com



## Austria Sales Office

Aredstrasse 22  
2544 Leobersdorf  
Austria  
Tel: +43 2256 655 84  
Fax: +43 2256 645 12  
info@at.tdk-lambda.com  
www.de.tdk-lambda.com



## Switzerland Sales Office

Bahnhofstrasse 50  
8305 Dietlikon  
Switzerland  
Tel: +41 44 850 53 53  
Fax: +41 44 850 53 50  
info@ch.tdk-lambda.com  
www.de.tdk-lambda.com



## Nordic Sales Office

Haderslevvej 36B  
DK-6000 Kolding  
Denmark  
Tel: +45 2911 9556  
info@dk.tdk-lambda.com



## TDK-Lambda UK Ltd.

Kingsley Avenue  
Ilfracombe  
Devon EX34 8ES  
United Kingdom  
Tel: +44 (0) 12 71 85 66 66  
Fax: +44 (0) 12 71 86 48 94  
powersolutions@uk.tdk-lambda.com  
www.uk.tdk-lambda.com



## TDK-Lambda Ltd.

Kibbutz  
Givat Hashlosha 48800  
Israel  
Tel: +9 723 902 4333  
Fax: +9 723 902 4777  
info@tdk-lambda.co.il  
www.tdk-lambda.co.il



## C.I.S.

**Commercial Support:**  
Tel: +7 (495) 665 2627  
**Technical Support:**  
Tel: +7 (812) 658 0463  
info@tdk-lambda.ru  
www.tdk-lambda.ru

## Local Distribution

