

# Specification

## Patent Pending

- Part No. : **UWC.01**
- Description : 6~8GHz Ultra-Wide Band (UWB)  
SMD Chip Antenna
- Features : SMD Chip UWB Antenna  
For European and USA UWB Applications  
In Channels 5-7
- Uses
- Automotive sensors
  - Smart airbags
  - Precision surveying
  - Smart home and entertainment systems
  - Centimeter Level Positioning

Frequency: 6.0-8GHz

Dims: 5.5\*5.5\*2mm

RoHS Compliant



## 1. Introduction

The UWC.01 chip antenna, at 5.5\*5.5\*2 mm, is a small form factor Ultra-Wideband (UWB) antenna with high efficiencies across the pulsed UWB communications operational bands. It is mounted to a PCB via standard SMT reflow process. It enables designers to use only one antenna that covers all common UWB commercial bands, namely bands, 5, 6 and 7 simultaneously.

The UWC.01 antenna is a durable ceramic antenna that has a peak gain of 4dBi, an efficiency of more than 50% across the bands and is designed to be mounted directly onto a PCB. It is an ideal choice for any device maker that needs to keep manufacturing costs down over the lifetime of a product. Like all such antennas, care should be taken to mount the antenna at least 3mm from metal components or surfaces, and ideally 5mm for best Radiation efficiency. Minimum recommended ground plane size is 25 mm x 13 mm, and antenna to ground clearance is fixed to 0.3 mm and should not be changed (please see section 7. Application Note).

Ultra-Wideband (also known as UWB) is a low power digital wireless technology for transmitting large amounts of digital data over a wide spectrum of frequency bands typically spanning more than 500MHz with very low power for short distances.

The low power requirements of UWB mean increased battery life of sensors and tags leading to reduction in overall operational costs. Taoglas has developed various innovative and new-to-market flexible embedded UWB antennas designed for seamless integration on plastics and using highly flexible micro-coaxial cable mounting while achieving high performance where space is limited. Taoglas UWB antennas have been designed for use with the recently launched Decawave ScenSor DW1000 module and are also compatible with any other UWB sensor modules on the market.

## 1.1. Applications of Pulsed UWB antenna Technology

**Radar** - These short-pulsed antennas provide very fine range resolution and precision distance and positioning measurement capabilities. UWB signals enable inexpensive high definition radar antennas which find use in automotive sensors, smart airbags, and precision surveying applications amongst many others.

**Home Network Connectivity** - Smart home and entertainment systems can take advantage of high data rates for streaming high quality audio and video contents in real time for consumer electronics and computing within a home environment.

**Position location & Tracking**- UWB antennas also find use in Position Location and Tracking applications such as locating patients in case of critical condition, hikers injured in remote areas, tracking cars, and managing a variety of goods in a big shopping mall. UWB offers better noise immunity and better accuracy to within a few cm compared to current localization technologies such as Assisted GPS for Indoors, Wi-Fi and cellular which are at best able to offer meter level precision. Tethered Indoor Positioning UWB systems that measure the angles of arrival of ultra-wideband (UWB) radio signals perform triangulation by using multiple sensors to communicate with a tag device.

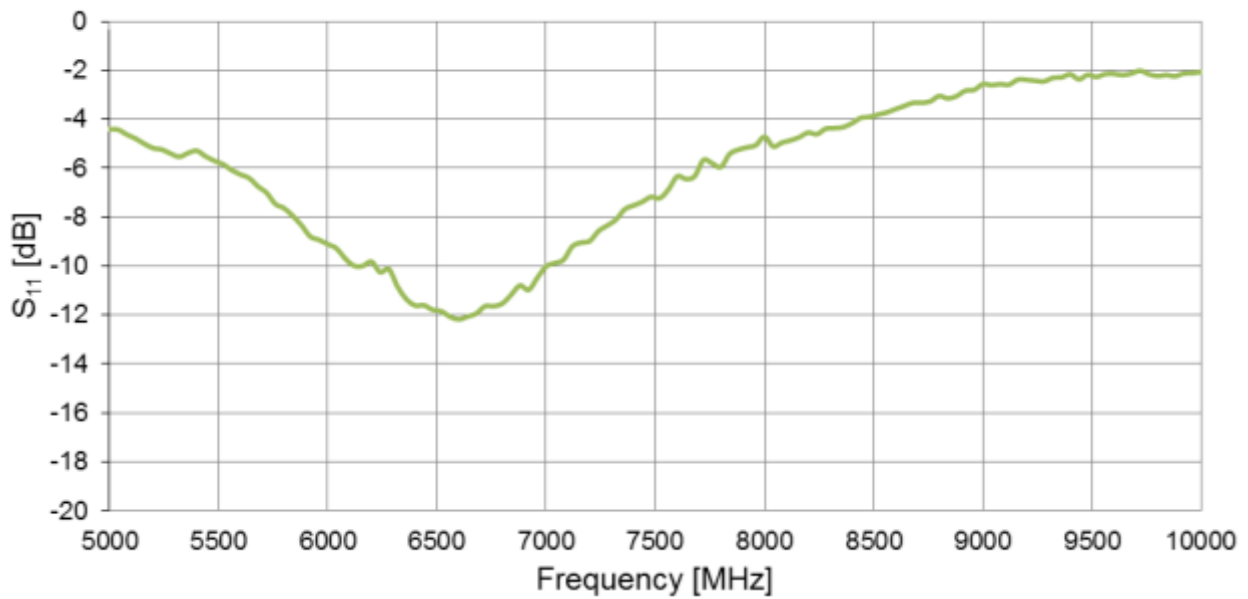
## 2. Specification

ELECTRICAL			
STANDARD	EU UWB		
	USA UWB Channel 5	USA UWB Channel 6	USA UWB Channel 7
Operation Frequency (GHz)	6.24-6.74	6.74-7.24	5.95-7.03
Return Loss (dB)	-10	-8	-9
Efficiency (%)	70	60	70
Peak Gain (dBi)	4.5	3.5	4.5
Max VSWR	2:1	2.7:1	2.2:1
Radiation Properties	Omnidirectional		
Polarization	Linear		
Impedance (Ohms)	50		
Max input Power (Watts)	10		
MECHANICAL			
Dimension	5.5 x 5.5 x 2mm		
Material	Ceramic		
ENVIRONMENTAL			
Operation Temperature	-40°C to 85°C		
Storage Temperature	-40°C to 85°C		
Humidity	40% to 90%		

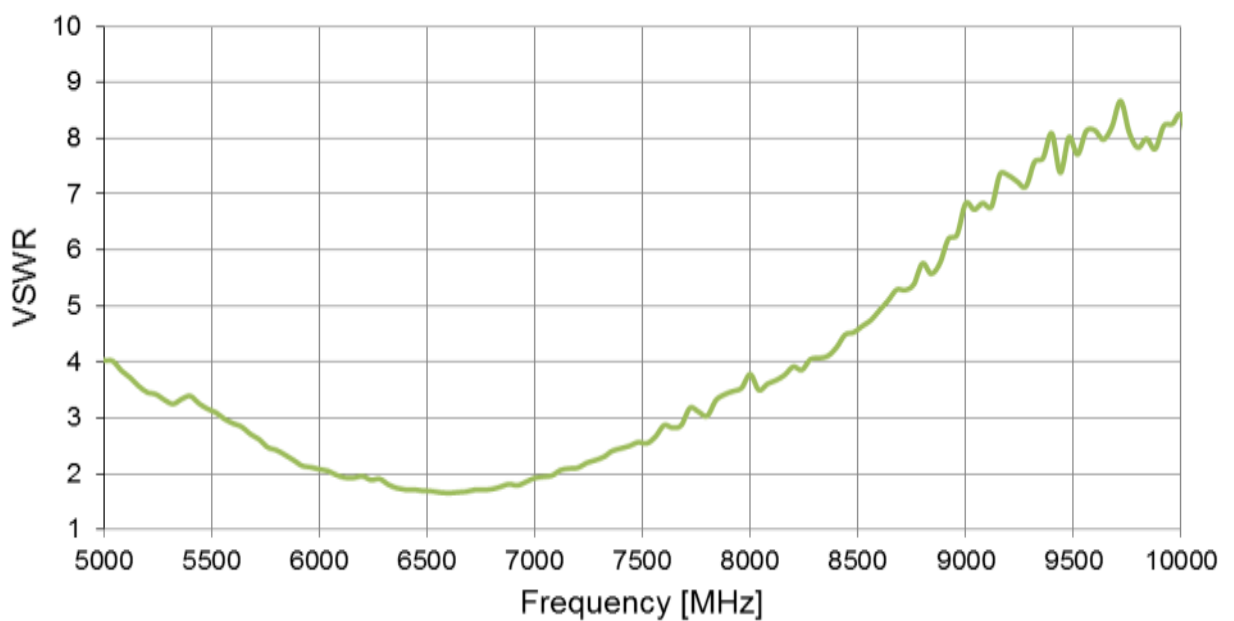
\* Results obtained for antenna on Standard Evaluation Board size 25\*20mm, with 25\*13mm ground plane.

### 3. Antenna Characteristics

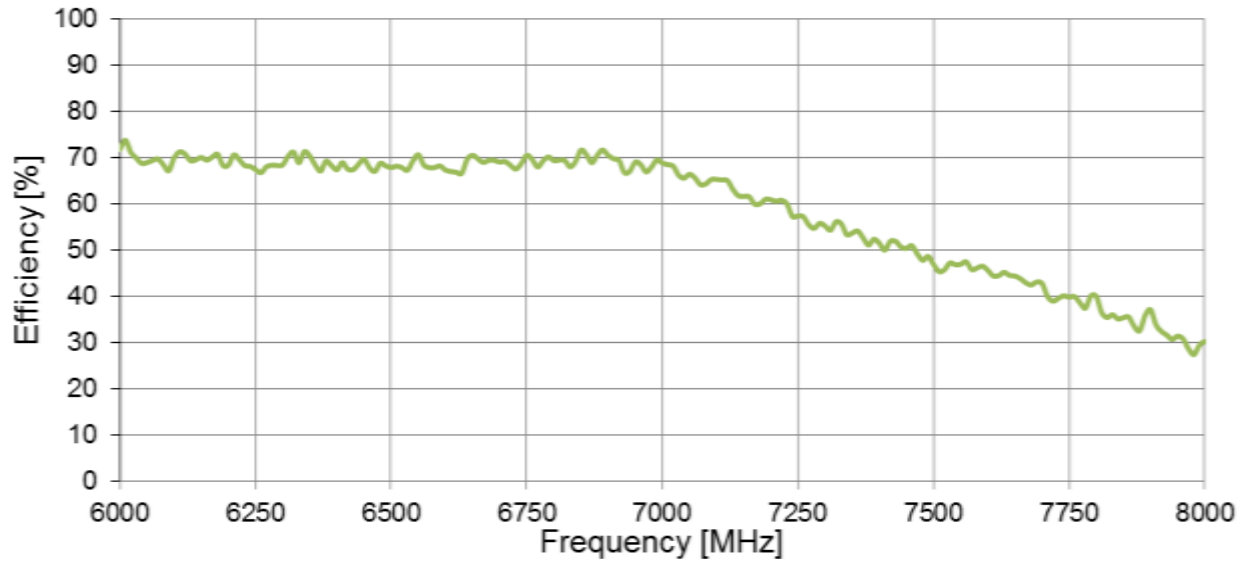
#### 3.1. Return Loss



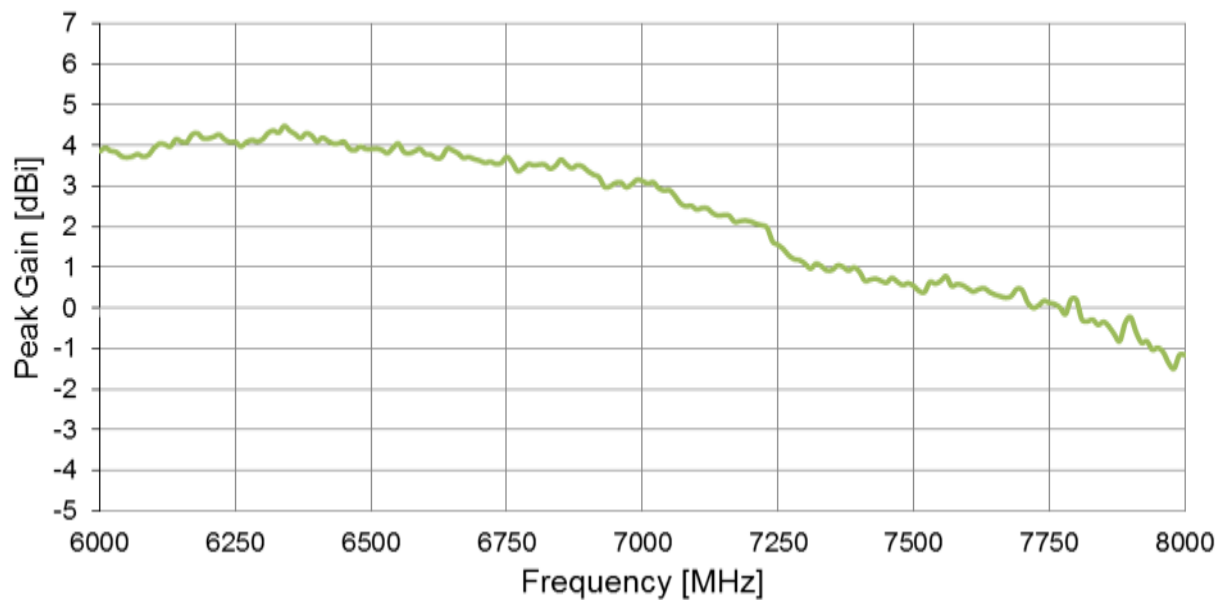
#### 3.2. VSWR



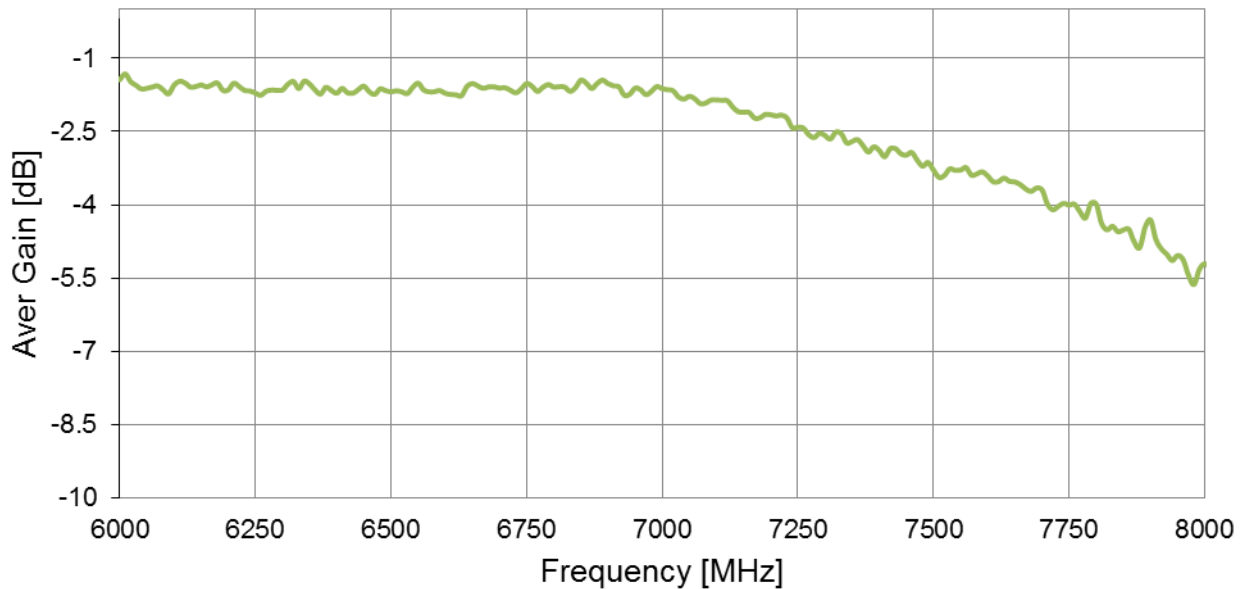
### 3.3. Efficiency



### 3.4. Peak Gain



### 3.5. Average Gain



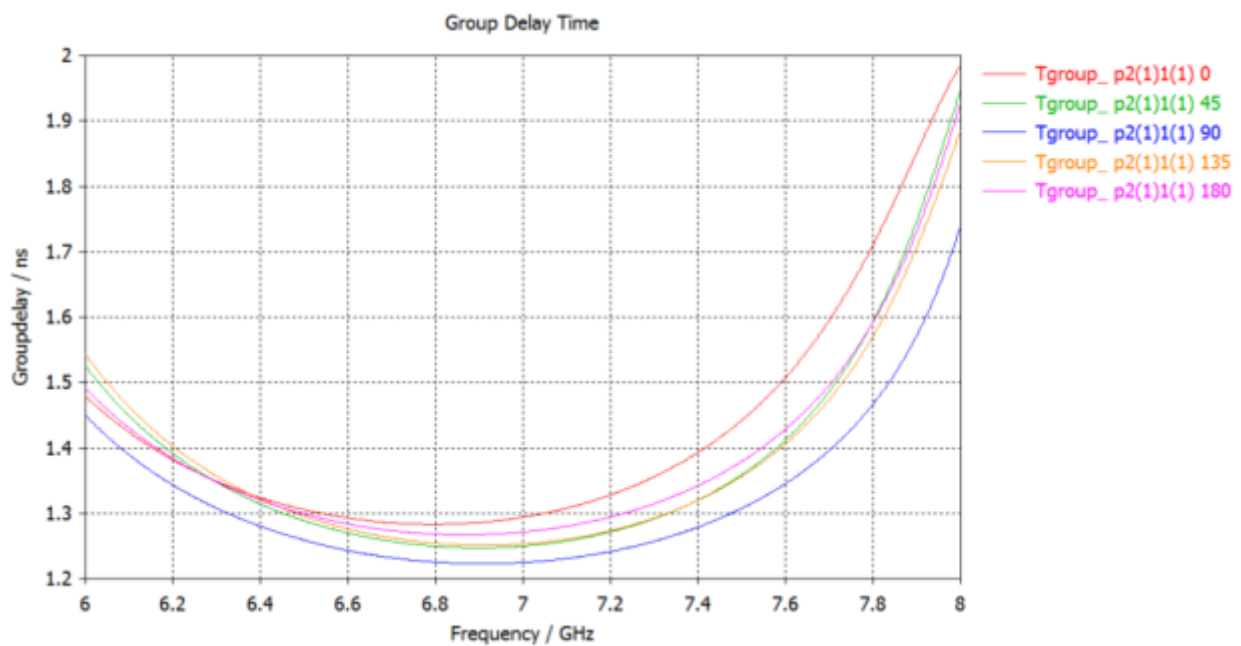
### 3.6. Group Delay (XY Plane) at 6.5GHz

The Total System Group Delay (in seconds) is the total time delay or transmit time of the amplitude envelopes of the various sinusoidal components of UWB signals through a device or link budget system. Effectively it is the propagation delay in transmitting antenna (Tx), propagation channel (Ch), and in receiving antenna (Rx) summed together.

An even more important parameter is the Group Delay Variation over Theta Angle from an average constant group delay. The group delay ripple is used to quantify this deviation. Ultimately, deviations from a maximally flat or constant group delay represent distortions in the output signal which is undesirable. A group delay variation of 100-150ps or less is considered acceptable for UWB system implementation.

### 3.7. Group Delay Vs Frequency

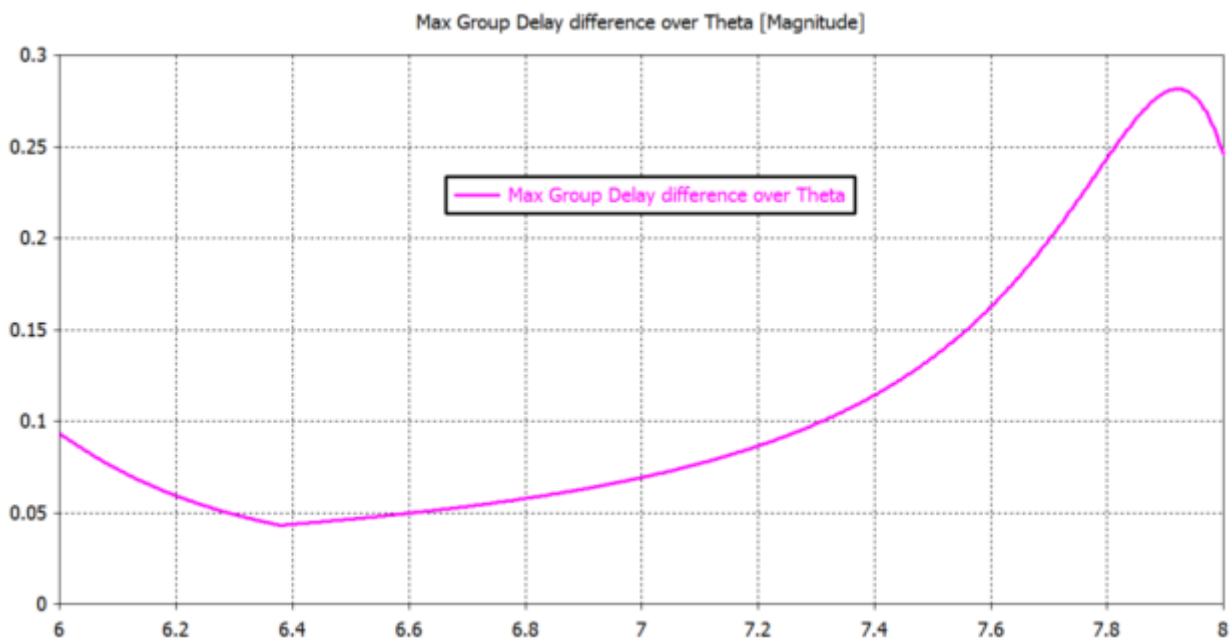
The group delay was simulated for two UWC.01 antennas placed at a far-field distance of 1m distance. One of the antennas was kept stationary, while the other was rotated in 45° intervals.





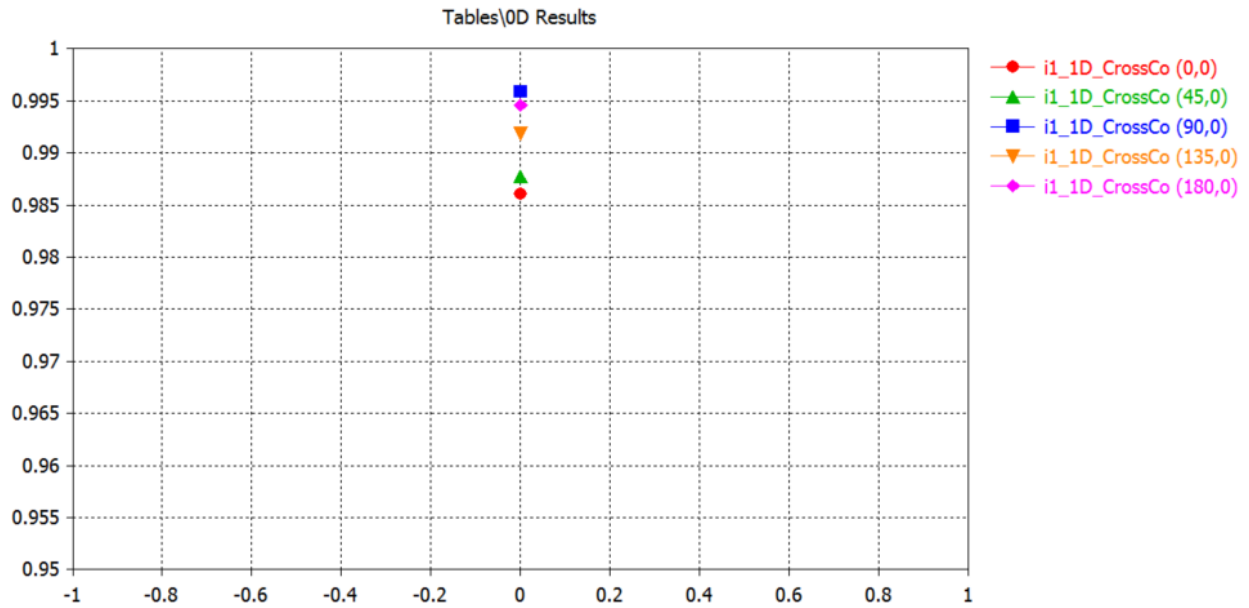
### 3.8. Group Delay Vs Theta at 6.5GHz

The calculated Maximum difference between the highest value and the lowest Group Delay value is presented below. The UWC.01 antenna presents Group Delay variation smaller than 100 ps (benchmark) from 6GHz up to 7.3GHz spanning UWB channels 5-7.



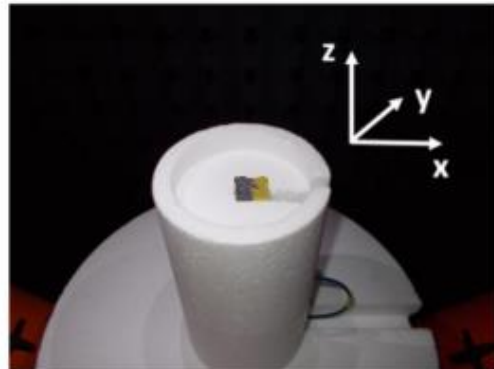
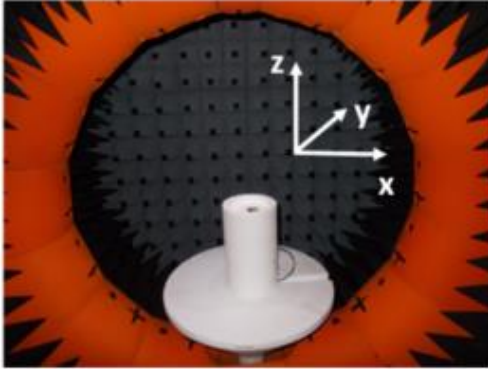
### 3.9. Fidelity Factor vs. Theta Angle

The fidelity is above 0.9 (benchmark value) for all Theta angles, therefore UWC.01 shows very good performance.



## 4. Antenna Radiation Pattern

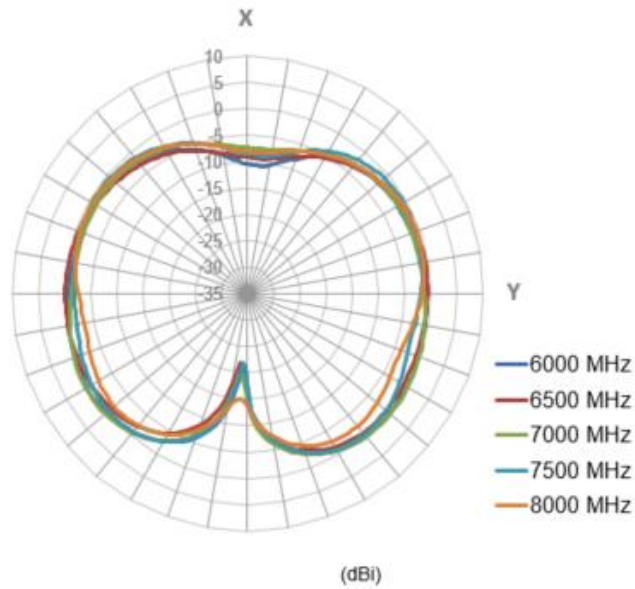
### 4.1. Measurement Setup



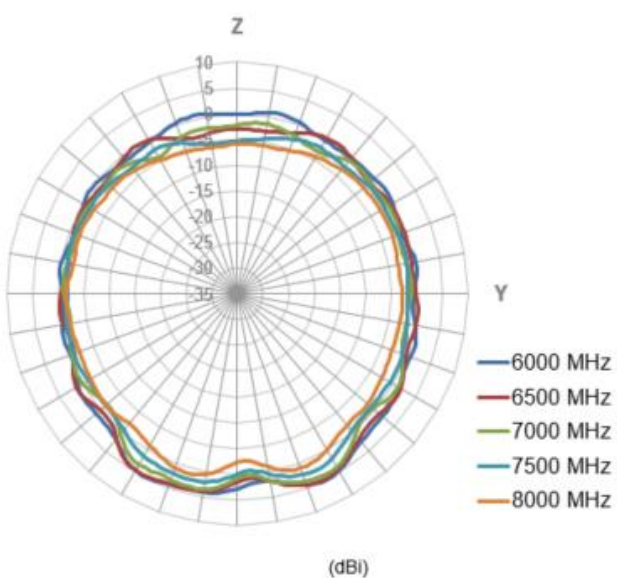


## 4.2. 2D Radiation Pattern (dBi)

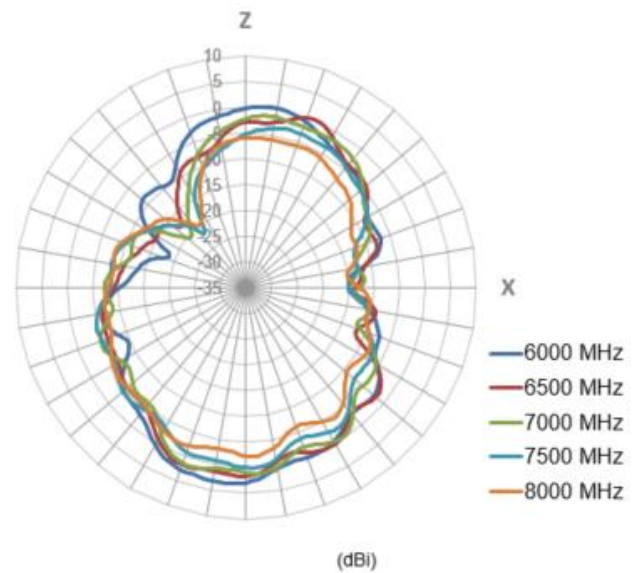
### XY Plane



### YZ Plane



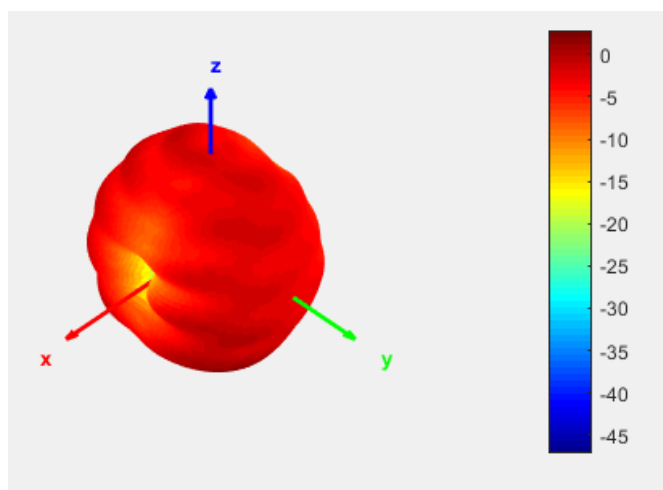
### XZ Plane



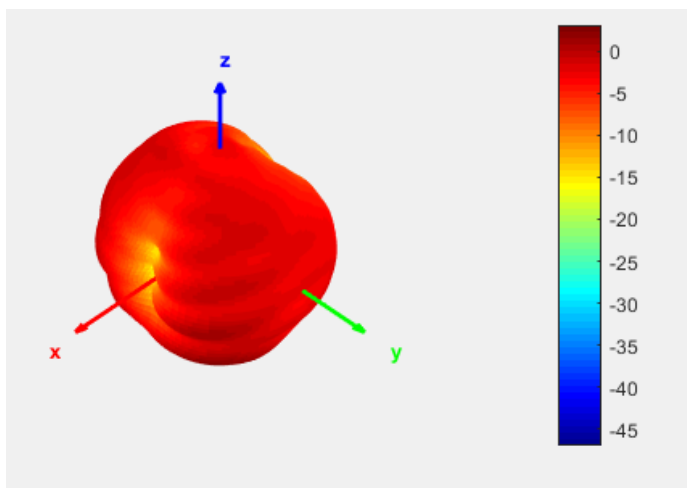


## 4.3. 3D Radiation Pattern (dBi)

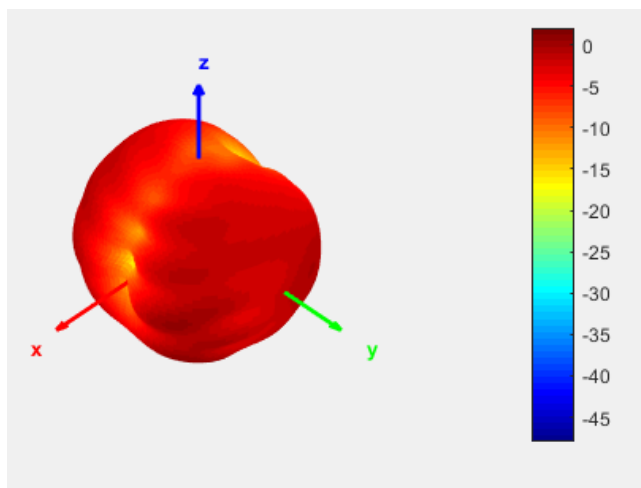
6GHz



7GHz



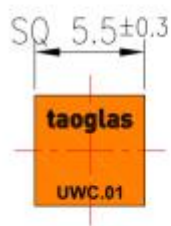
8GHz



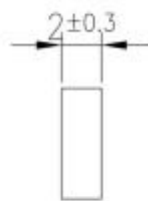
## 5. Mechanical Drawing

### 5.1. Antenna Drawing (Unit: mm)

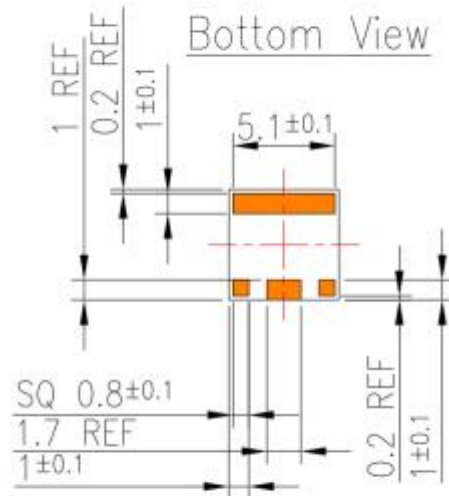
Top View



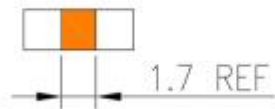
Right View



Bottom View



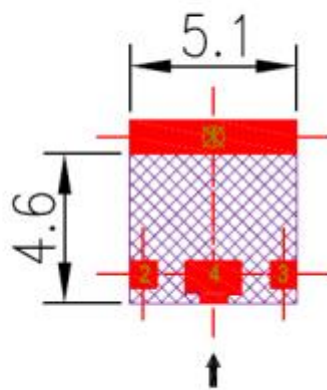
Front View



## 5.2. Recommended PCB Layout

### 5.2.1. Top Copper

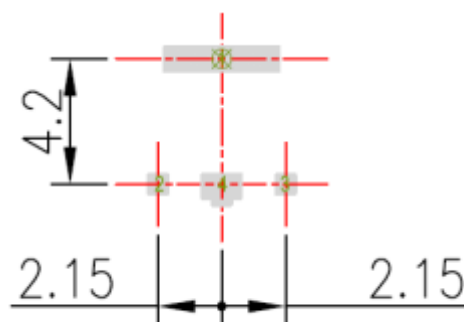
Pad 4 should be connected to a 50 ohm transmission line.



→ :  
Connected to 50 ohm  
transmission line.

### 5.2.2. Top Solder Paste

Pads 2 and 3 are the same size.



**NOTE:**

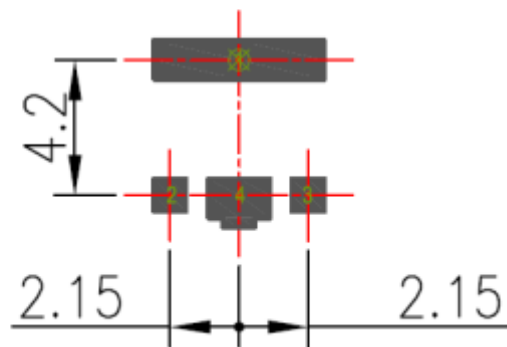
- 1. Ag Plated area
- 2. Solder Mask area
- 3. Copper area
- 4. Paste area
- 5. Copper Keepout Area



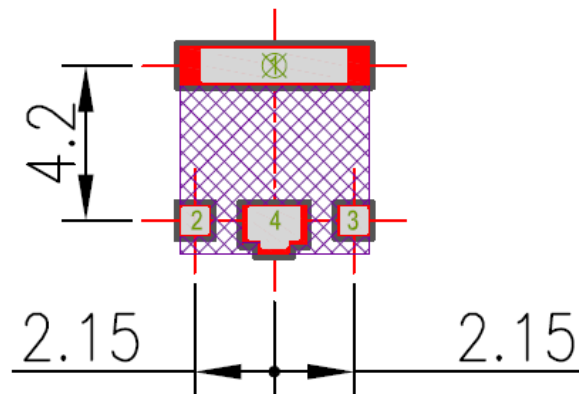
- 6. Ground keepout should extend from top layer through all inner PCB layers to minimize coupling from RF feed to ground.
- 7. Any vias in pads should be either filled or tented to prevent solder from wicking away from the pad during reflow.
- 8. The dimension tolerances should follow standard PCB manufacturing guidelines
- 9. " \* " Critical Dimensions.

### 5.2.3. Top Solder Mask

Pads 2 and 3 are the same size.  
 This drawing is a negative of solder mask.  
 Black regions are anti-mask.



### 5.2.4. Composite Diagram



**NOTE:**

- 1. Ag Plated area
- 2. Solder Mask area
- 3. Copper area
- 4. Paste area
- 5. Copper Keepout Area



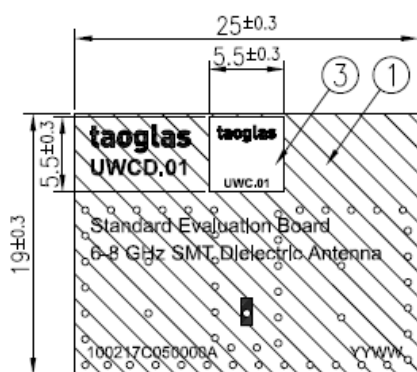
- 6. Ground keepout should extend from top layer through all inner PCB layers to minimize coupling from RF feed to ground.
- 7. Any vias in pads should be either filled or tented to prevent solder from wicking away from the pad during reflow.
- 8. The dimension tolerances should follow standard PCB manufacturing guidelines
- 9. " \* " Critical Dimensions.



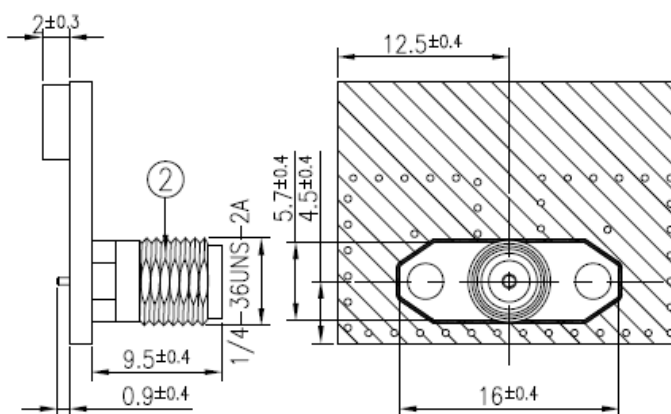


## 5.3. Evaluation Board

Front View



Side View



Back View

Notes:

1. Soldered area
2. Soldermask area(Black)
3. Logo & Text Ink Printing : White

	Name	Material	Finish	QTY
1	UWCD.01 EVB PCB	Composite 1.6t	Black	1
2	SMA(F)ST	Brass	Au Plated	1
3	UWC.01 Antenna	Ceramic	Nature	1

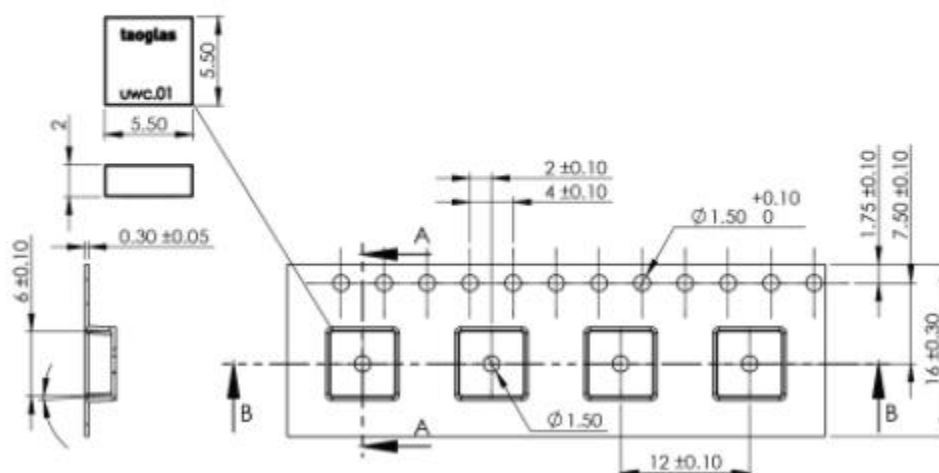


## 6. Packaging

1200 pc UWC.01 per reel  
Dimensions - Ø330\*20.4mm  
Weight - 583g



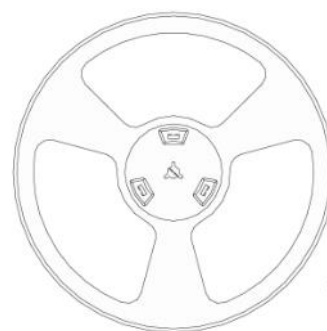
330mm



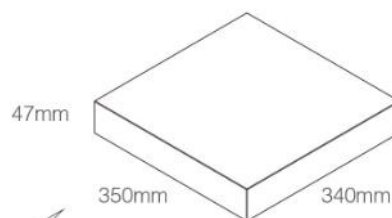


# TAOGLAS®

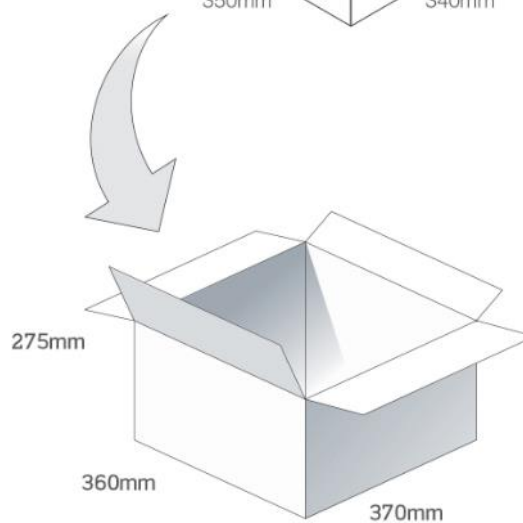
1200 pcs UWC.01 reel  
Dimensions - 330\*330\*20.4mm  
Weight - 583g



1200 pcs UWC.01 / 1 Reel in small box  
Dimensions - 350\*340\*47mm  
Weight - 0.86Kg

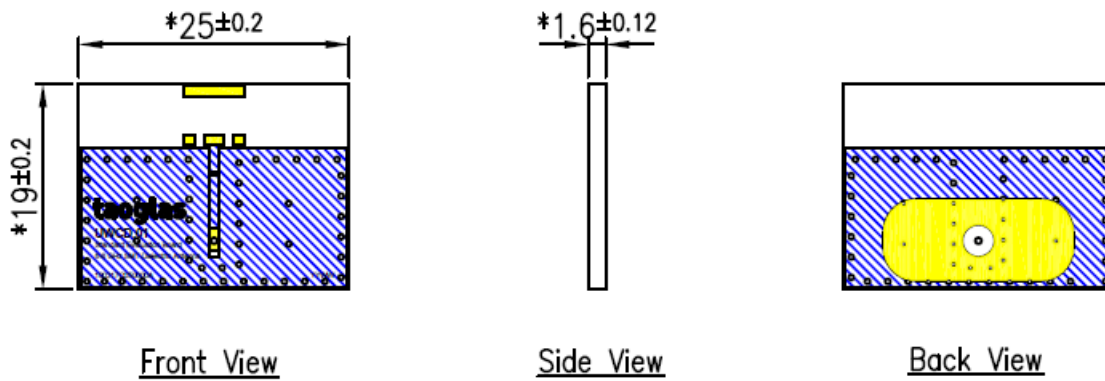


5 small boxes, 6000 pcs in one carton  
Carton Dimensions - 360\*370\*275mm  
Weight - 4.3Kg



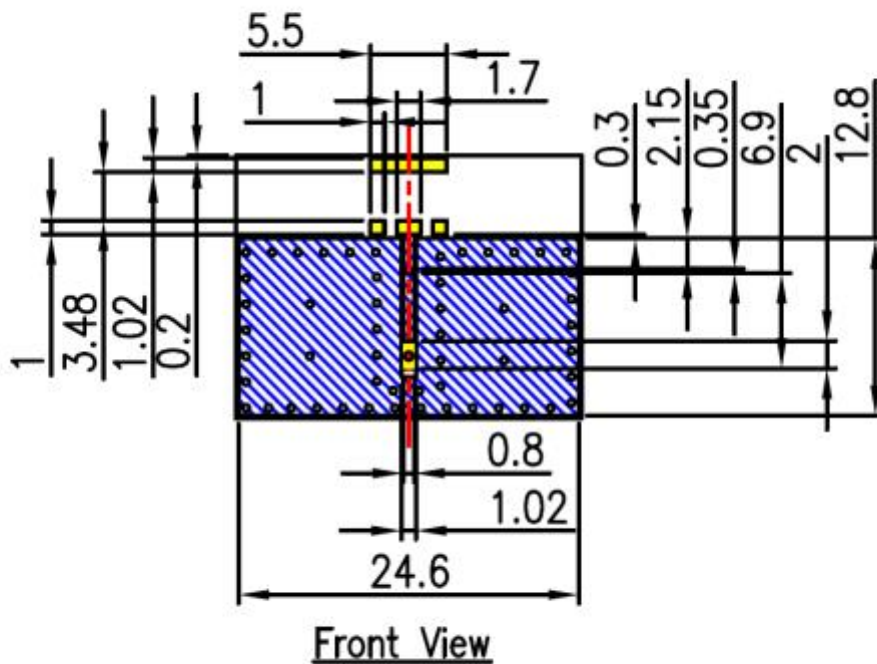
## 7. Application Notes

### 7.1. Recommended Placement and Ground Plane Size

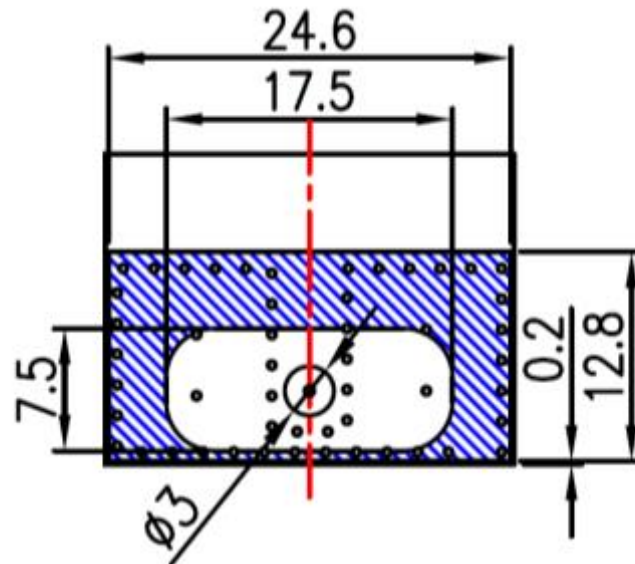


**Figure 1** - Evaluation Board

Copper Lay  Plated Lay 



**Figure 2** - Detailed dimensions EVB Front

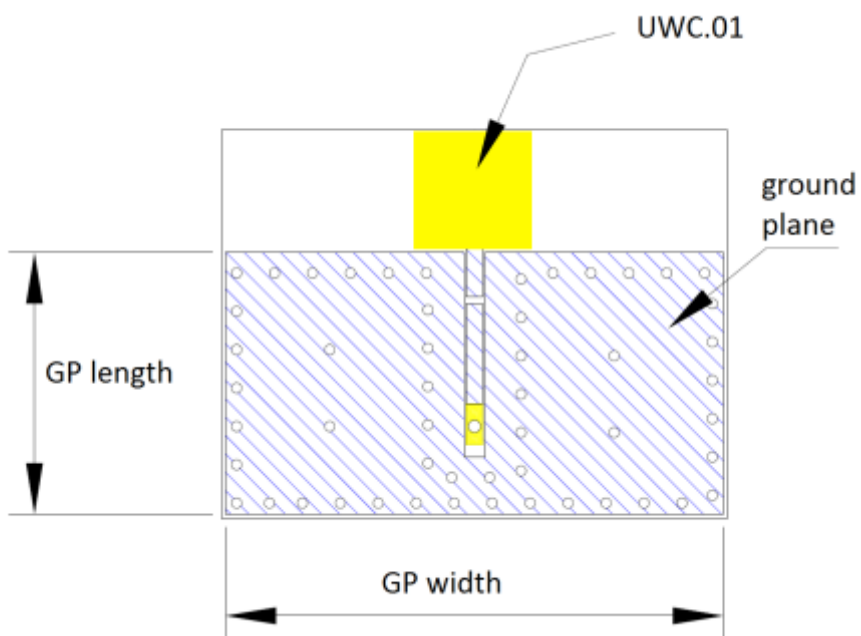


Back View

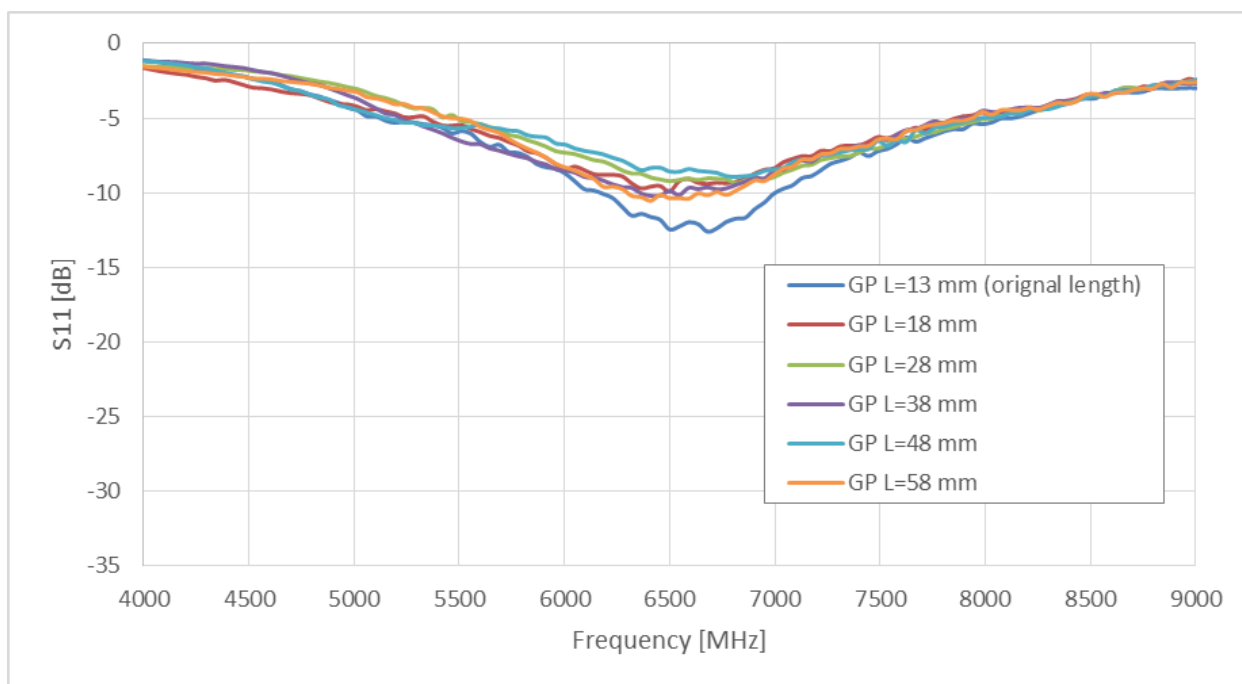
**Figure 3** - Detailed dimensions EVB Back

## 7.2. Ground Plane Size

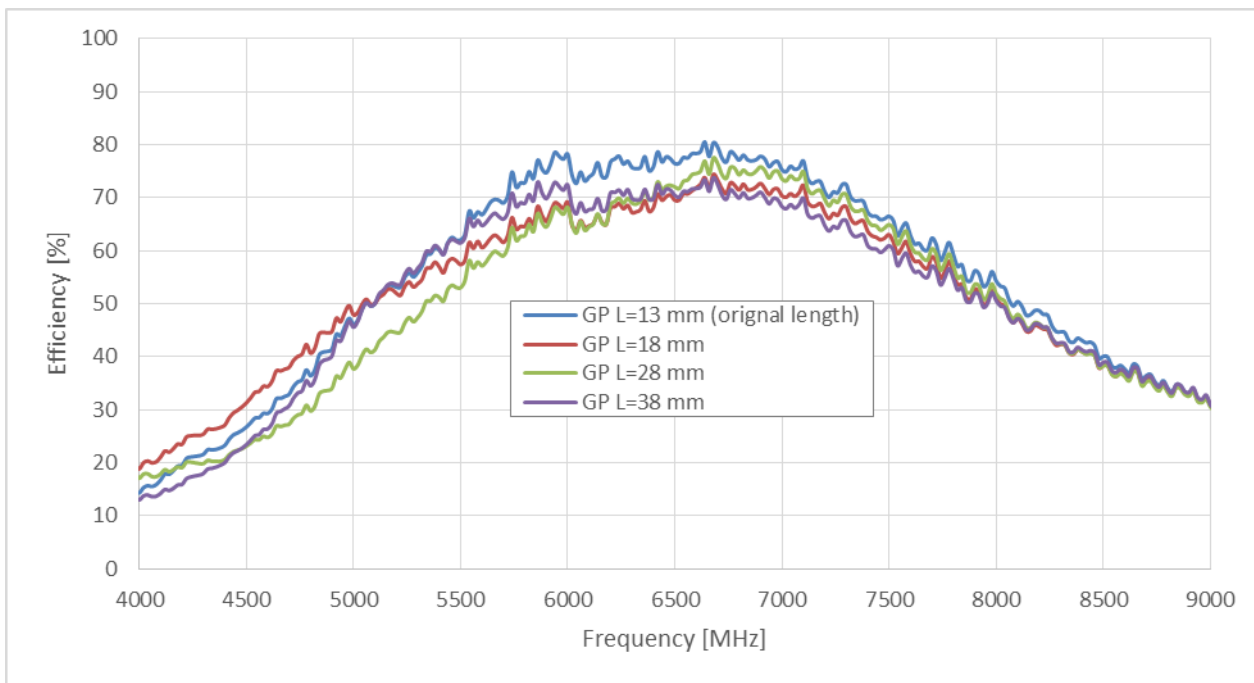
Influence of ground plane length and width is tested. Graphs below show that there is no significant influence on S11 or on Efficiency when the ground plane length is increased. Minimum recommended ground plane size is 25 mm x 13 mm. When the ground plane width is increased, either asymmetrically on one side or symmetrically on both sides, both S11 and efficiency the performance improves. In conclusion, it is preferred to mount the antenna on the longer side of the PCB.



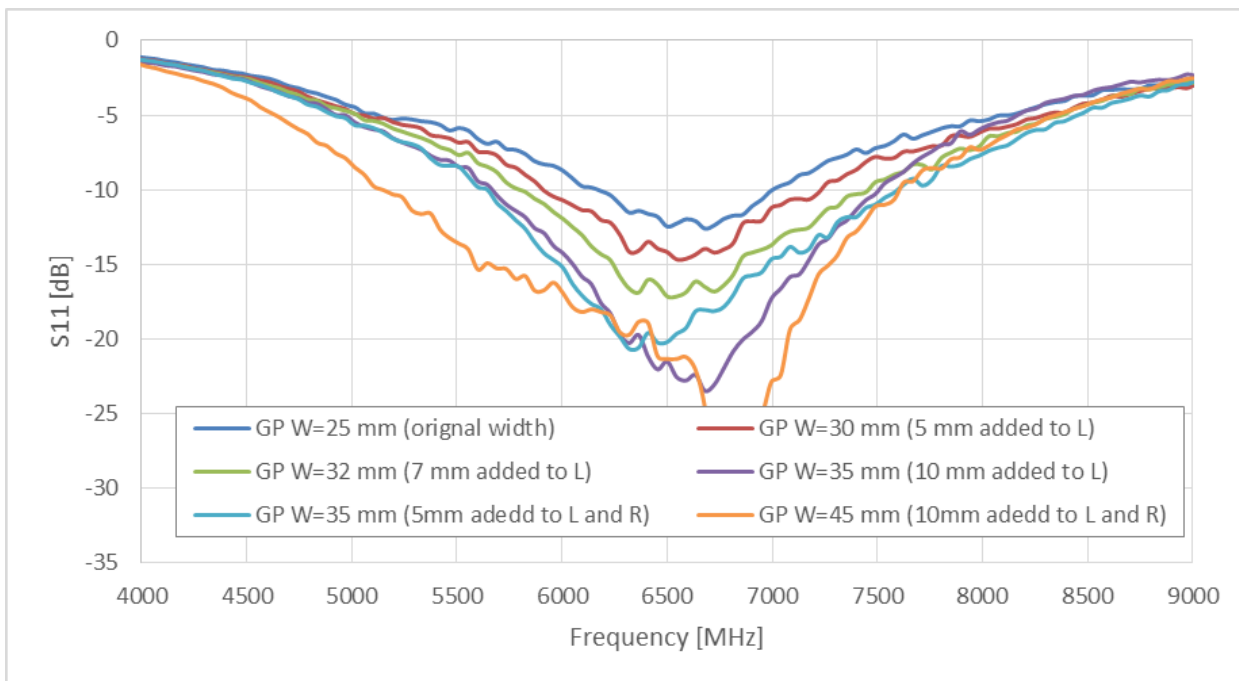
**Figure 4** - Evaluation Board Layout



**Figure 5** - Return Loss for ground plane length variation

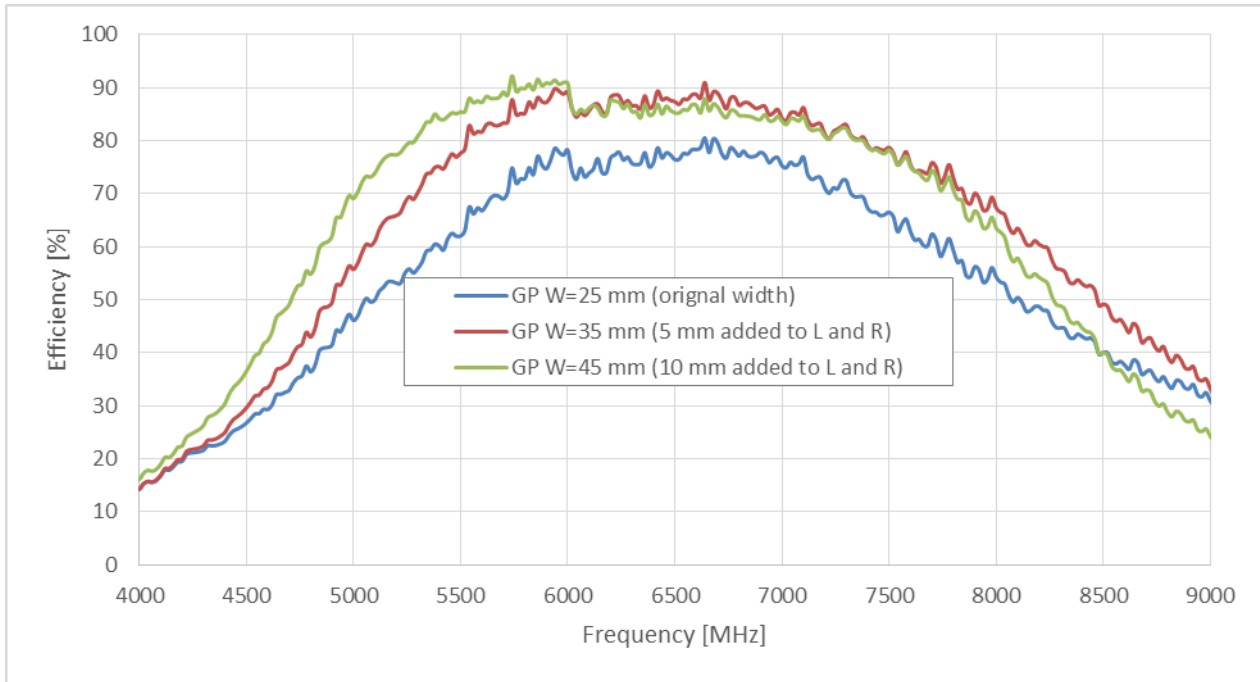


**Figure 6** - Efficiency<sup>1</sup> for ground plane length variation



**Figure 7** - Return Loss for ground plane width variation

<sup>1</sup> Jump at 6GHz happens due to use of two different physical measurement systems for frequencies below and above. The jump is around 0.25 dB and within chamber tolerance.



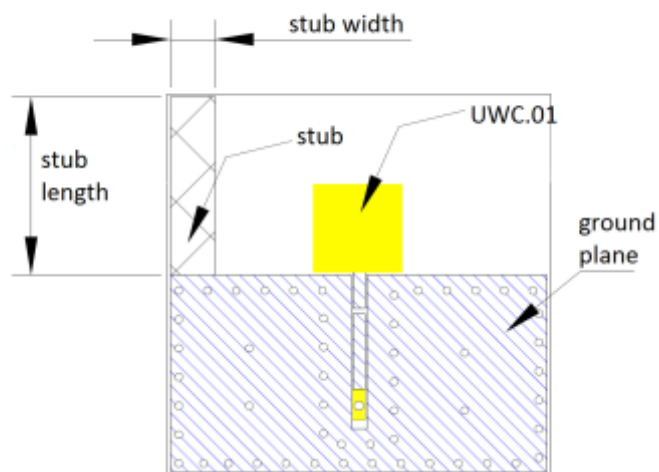
**Figure 8** - Efficiency<sup>1</sup> for ground plane width variation



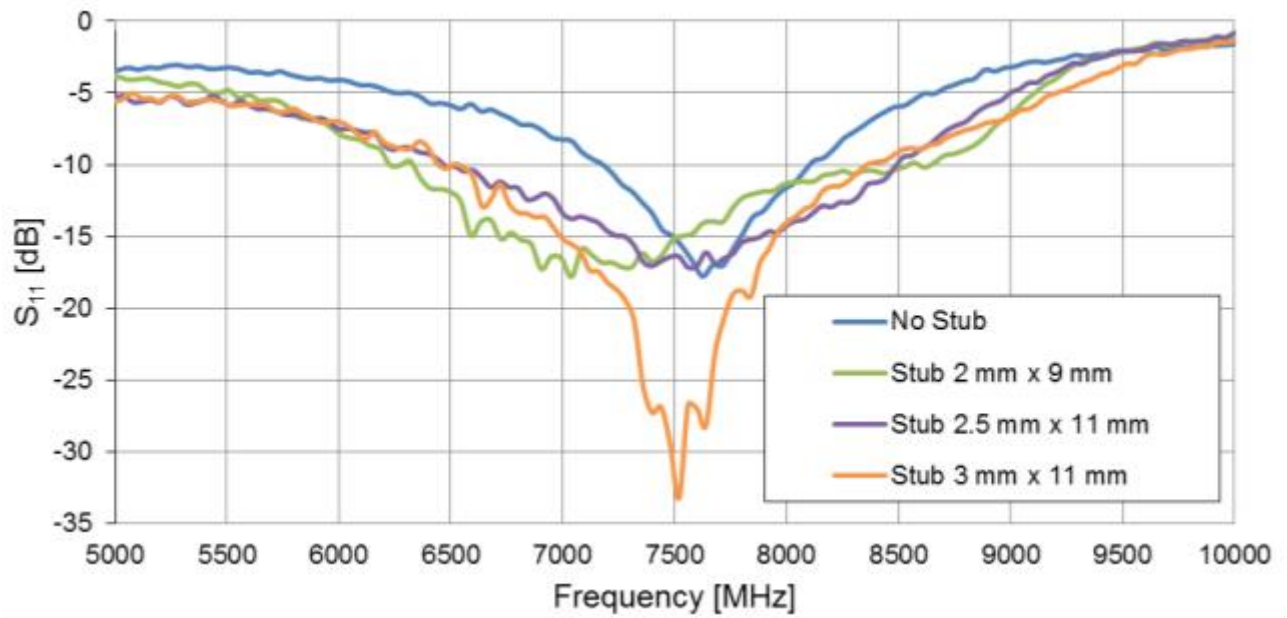
### 7.3. Tuning Stub for Impedance Matching Instead of Pi-Matching Circuit

The tuning stub is shown below in Figure 9. It is an extension of the ground plane (copper) into the clearance area around the UWC.01. The stub can be used instead of the matching circuit to achieve good impedance matching at 6.5-8GHz.

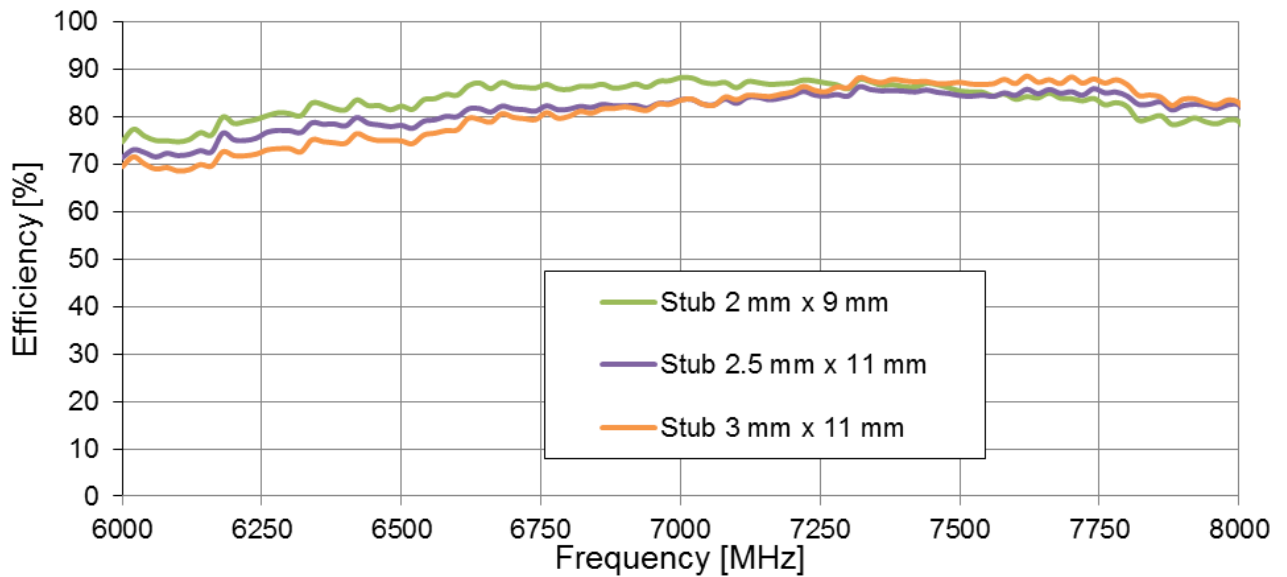
The results show it is possible to use a Tuning Stub instead of a Pi-matching-circuit, although it is possible to better match at 6.5GHz with the Pi-matching-circuit. The measurements also show that once the antenna is matched with a Pi-matching-circuit the stub on left or right does not influence the result significantly. However adding stubs simultaneously to left and right will negatively influence antenna performance.



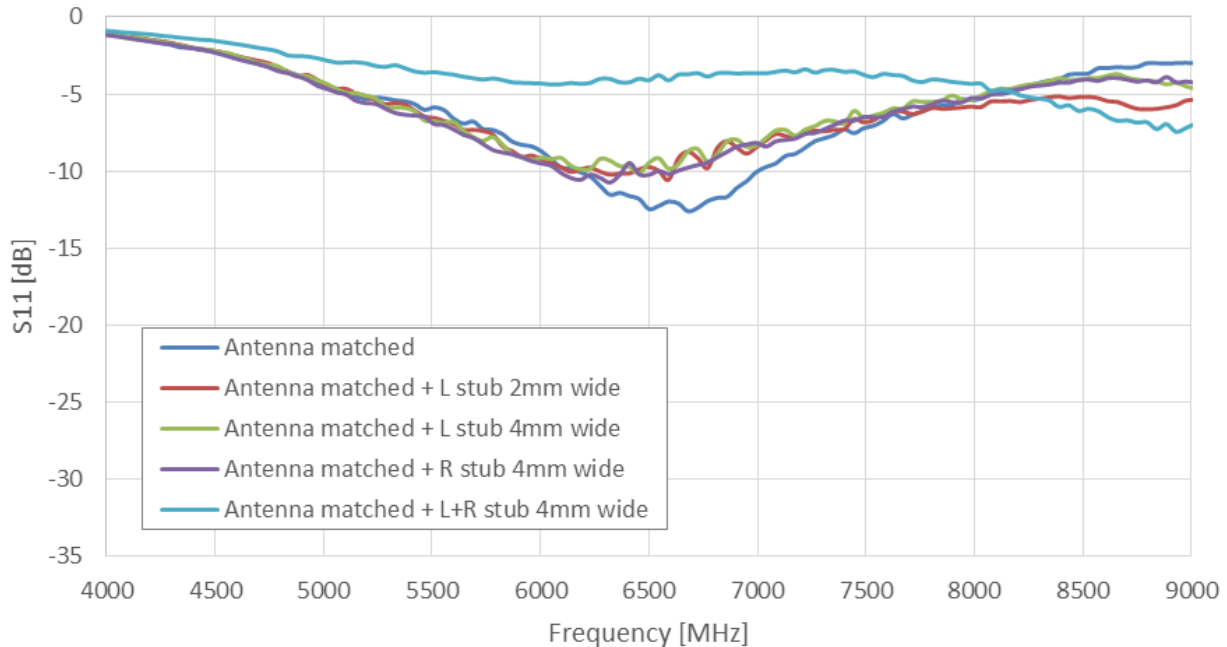
**Figure 9** - Evaluation Board Layout with Tuning Stub on the left side



**Figure 10** - Return Loss for UWC.01 matched with a tuning stub (No matching circuit)



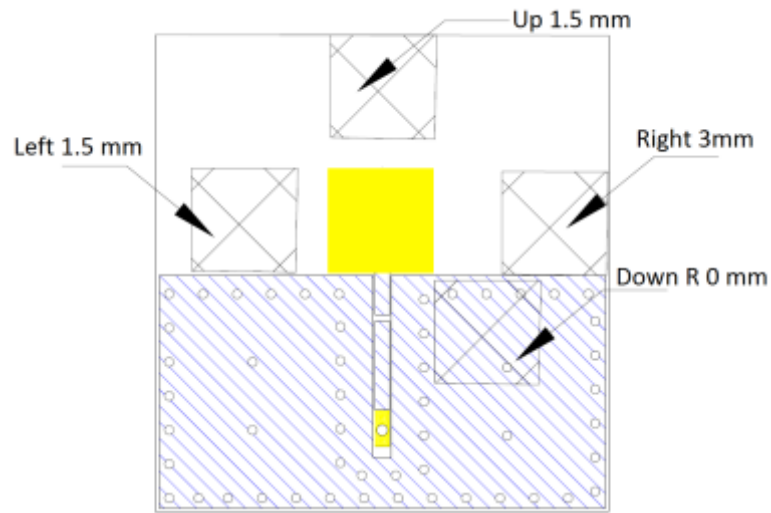
**Figure 11** - Efficiency for UWC.01 matched with a tuning stub (No matching circuit)



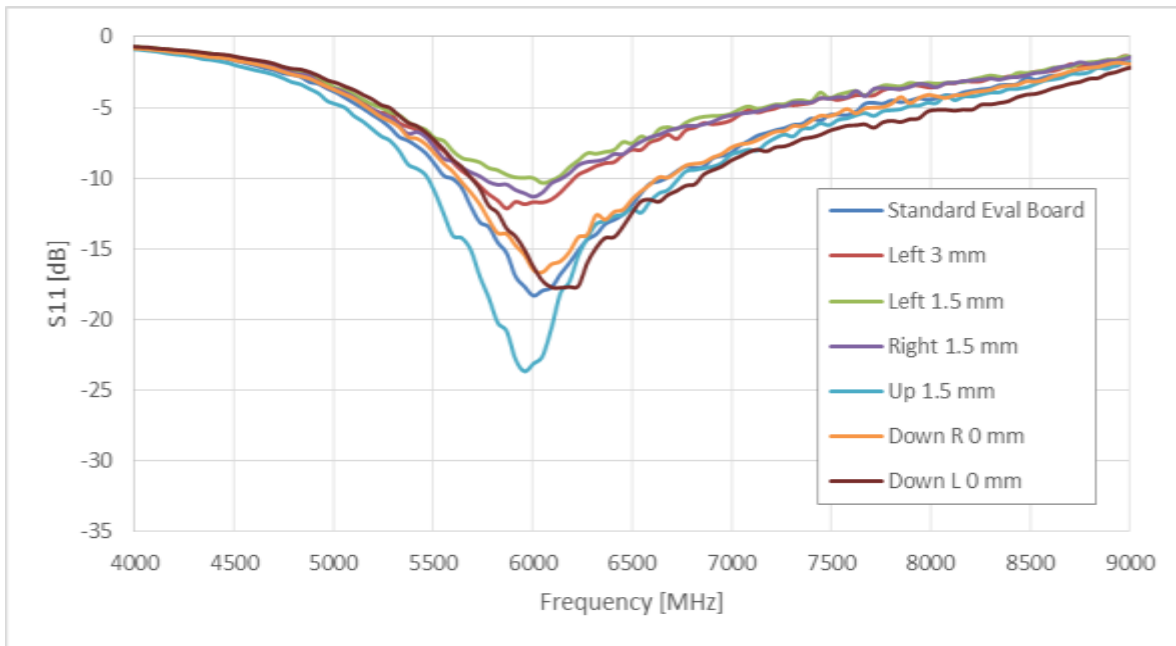
**Figure 12** - Return Loss for UWC.01 matched with a Pi-matching-circuit AND a tuning stub

## 7.4. Clearance Study

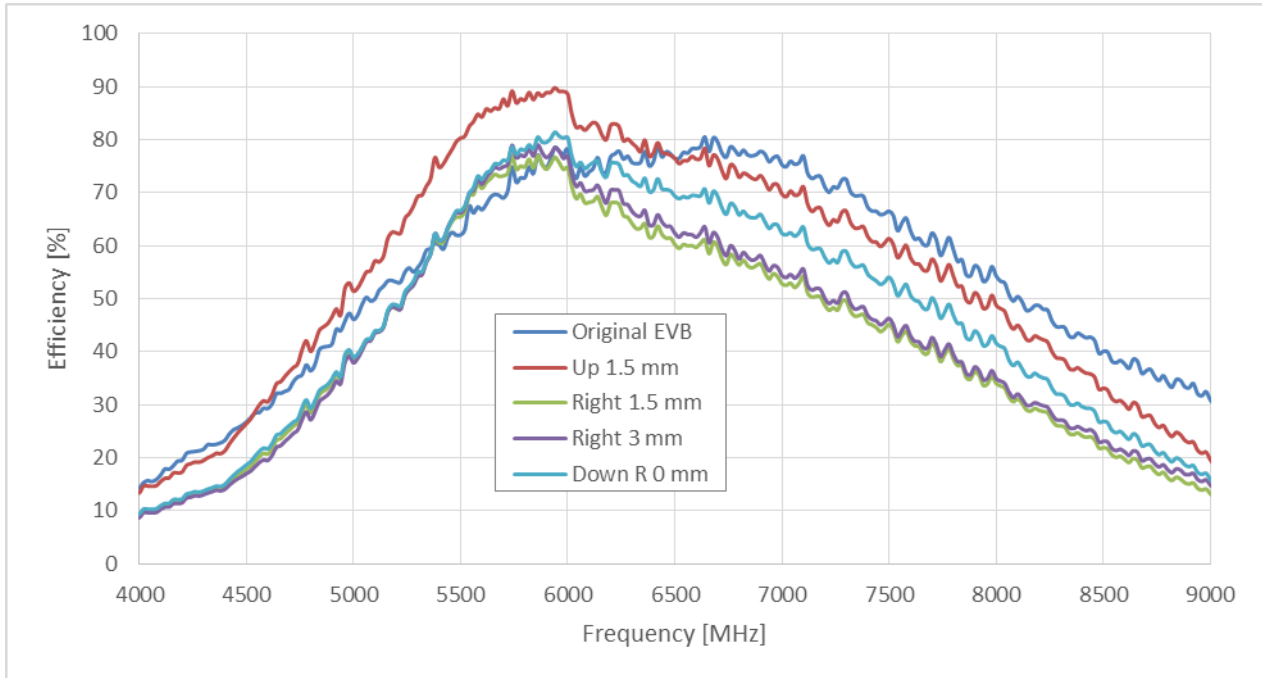
A metal clearance study is also performed with a 5\*5\*2mm metal component placed at different locations around the UWC.01 antenna as shown in Figure 13. The results show that close proximity of components on the left and right will slightly influence antenna impedance matching. The radiation pattern shows that the pattern is only influenced (skewed) when the component is placed 1.5 mm right or left from the antenna. Minimum recommended ground plane size is 25 mm x 13 mm and antenna to ground clearance is fixed to 0.3 mm and should not be changed. Results show that the optimum performance it is advised to keep any component at least 3 mm from the antenna and should be mounted on the outside edge of the ground plane.



**Figure 13** - Clearance study – metal component locations



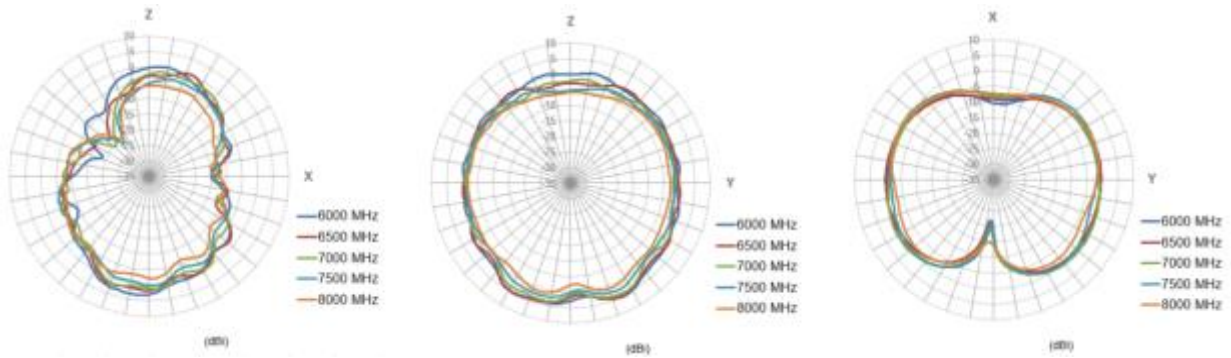
**Figure 14** - Return loss for clearance study



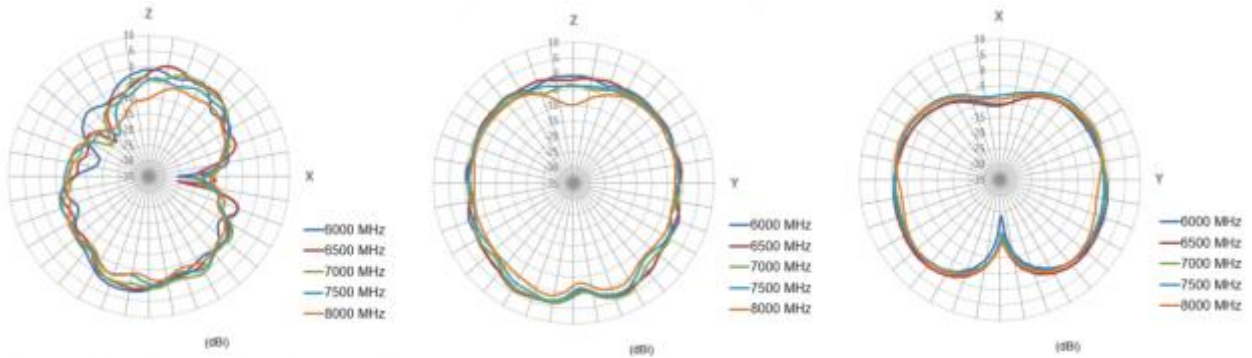
**Figure 15** - Efficiency for clearance study



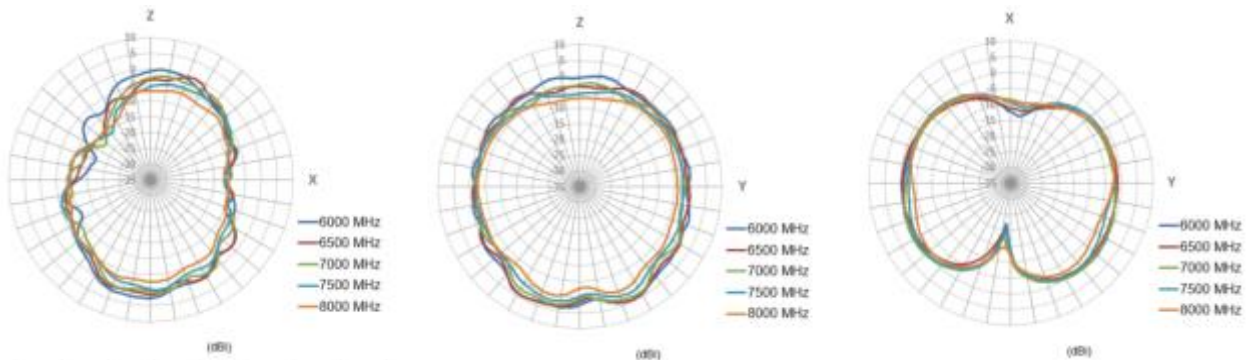
For the 2D radiation patterns the Chamber placement is equal to standard placement shown in Section 3.1 of this document.



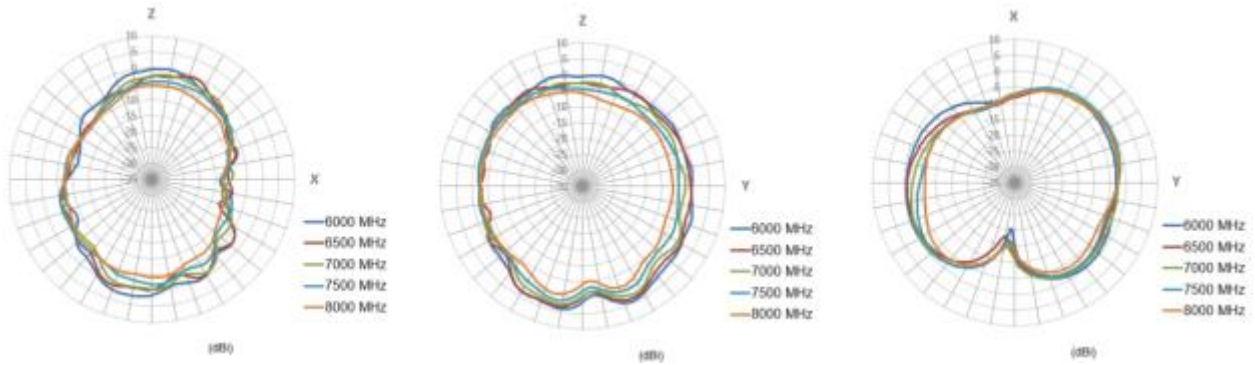
**Figure 16** - Radiation Pattern for standard EVB



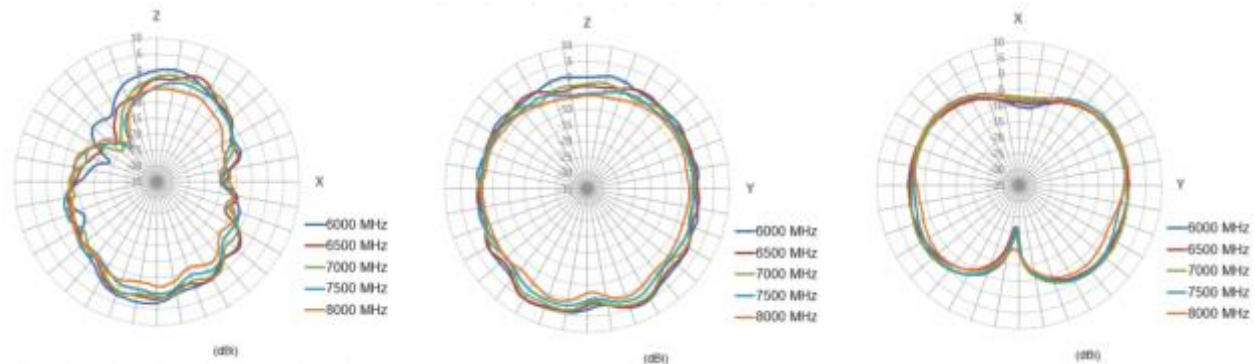
**Figure 17** - Radiation Pattern for Up 1.5 mm scenario



**Figure 18** - Radiation Pattern for Down R 0 mm scenario



**Figure 19** Radiation Pattern for Right 1.5 mm scenario



**Figure 20** Radiation Pattern for Right 3 mm scenario

Taoglas makes no warranties based on the accuracy or completeness of the contents of this document and reserves the right to make changes to specifications and product descriptions at any time without notice. Taoglas reserves all rights to this document and the information contained herein.

Reproduction, use or disclosure to third parties without express permission is strictly prohibited.

Copyright © Taoglas Ltd.