



TAOGLAS®



Datasheet

SWLP.2450.12.4.B.02

Description:

12*12*4mm 2.4GHz Wi-Fi SMD Patch Antenna

Features:

2.4 - 2.5GHz Wi-Fi Patch Antenna

For Wi-Fi/WLAN/ISM/Zigbee Industrial Applications

High Gain 2dBi

RoHS & Reach Compliant

1. Introduction	3
2. Specifications	4
3. Antenna Characteristics	5
4. 2D Radiation Patterns	7
5. 3D Radiation Patterns	10
6. Mechanical Drawing	12
7. Evaluation Board	13
8. Packaging	14

Taoglas makes no warranties based on the accuracy or completeness of the contents of this document and reserves the right to make changes to specifications and product descriptions at any time without notice. Taoglas reserves all rights to this document and the information contained herein.

Reproduction, use or disclosure to third parties without express permission is strictly prohibited.



1. Introduction



This 12*12*4mm high gain 2.4GHz patch antenna is ideally suited for high performance industrial applications in the 2.4GHz Wi-Fi, ISM, and Zigbee bands. This product has highest gain at broadside, most suitable for fixed wireless applications where transmission and reception is focused to one hemisphere of the device, for example a wireless meter on a reinforced concrete wall. It can also be placed anywhere on the device ground-plane, unlike most chip or loop antennas which need to be edge mounted.

Many module manufacturers specify peak gain limits for any antennas that are to be connected to that module. Those peak gain limits are based on free-space conditions. In practice, the peak gain of an antenna tested in free-space can degrade by at least 1 or 2dBi when put inside a device. So ideally you should go for a slightly higher peak gain antenna than mentioned on the module specification to compensate for this effect, giving you better performance.

Upon testing of any of our antennas with your device and a selection of appropriate layout, integration technique, or cable, Taoglas can make sure any of our antennas' peak gain will be below the peak gain limits. Taoglas can then issue a specification and/or report for the selected antenna in your device that will clearly show it complying with the peak gain limits, so you can be assured you are meeting regulatory requirements for that module.

For example, a module manufacturer may state that the antenna must have less than 2dBi peak gain, but you don't need to select an embedded antenna that has a peak gain of less than 2dBi in free-space. This will give you a less optimized solution. It is better to go for a slightly higher free-space peak gain of 3dBi or more if available. Once that antenna gets integrated into your device, performance will degrade below this 2dBi peak gain due to the effects of GND plane, surrounding components, and device housing. If you want to be absolutely sure, contact Taoglas and we will test. Choosing a Taoglas antenna with a higher peak gain than what is specified by the module manufacturer and enlisting our help will ensure you are getting the best performance possible without exceeding the peak gain limits.

2. Specifications

Electrical	
Frequency Range	2400~2500MHz
Bandwidth	100MHz @ -7dB
Efficiency	80.12% @ Centre Freq. 2450MHz
Polarization	Linear
VSWR	3.0 max @ Centre Freq. 2450MHz
Peak Gain	+2dBi typ.
Impedance	50Ω
Mechanical	
Dimensions	12*12*4mm
Weight	4g
Environmental	
Operating Temperature	-40°C to +85°C
Storage Temperature	-40°C to +85°C
Termination	Ag (Environmentally Friendly Pb Free)

3. Antenna Characteristics

3.1 Return Loss

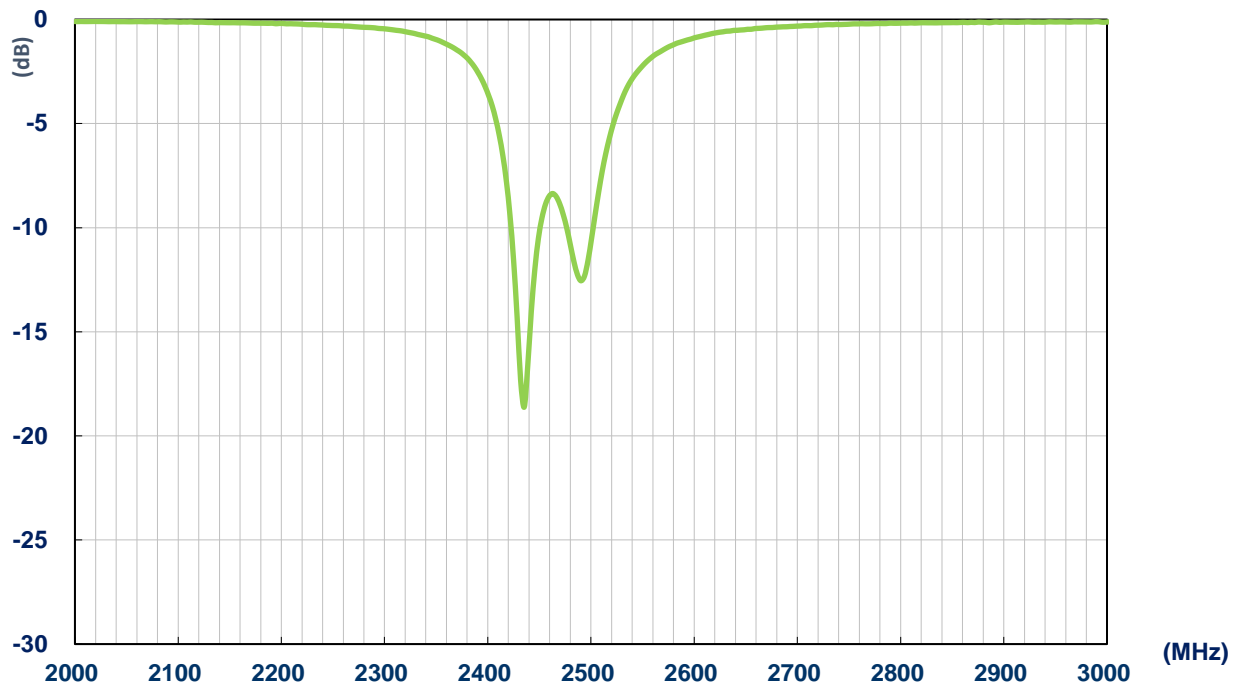

3.2 Efficiency

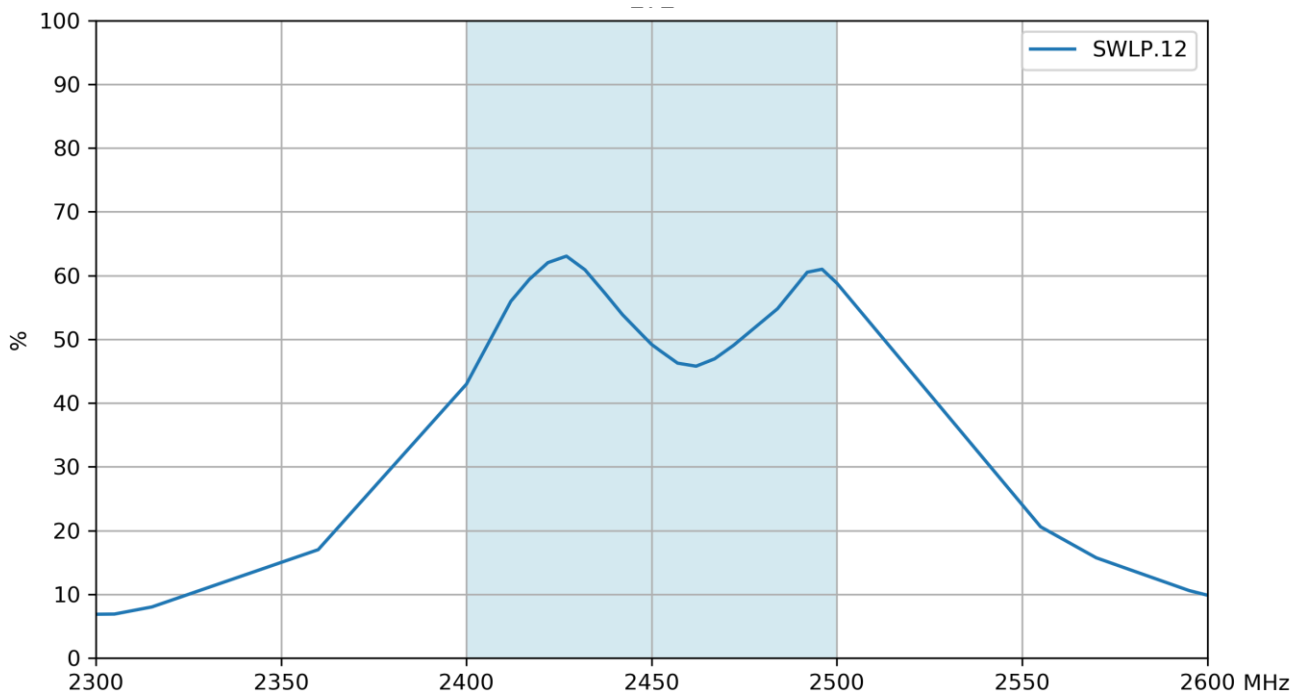

3.3 Average Gain

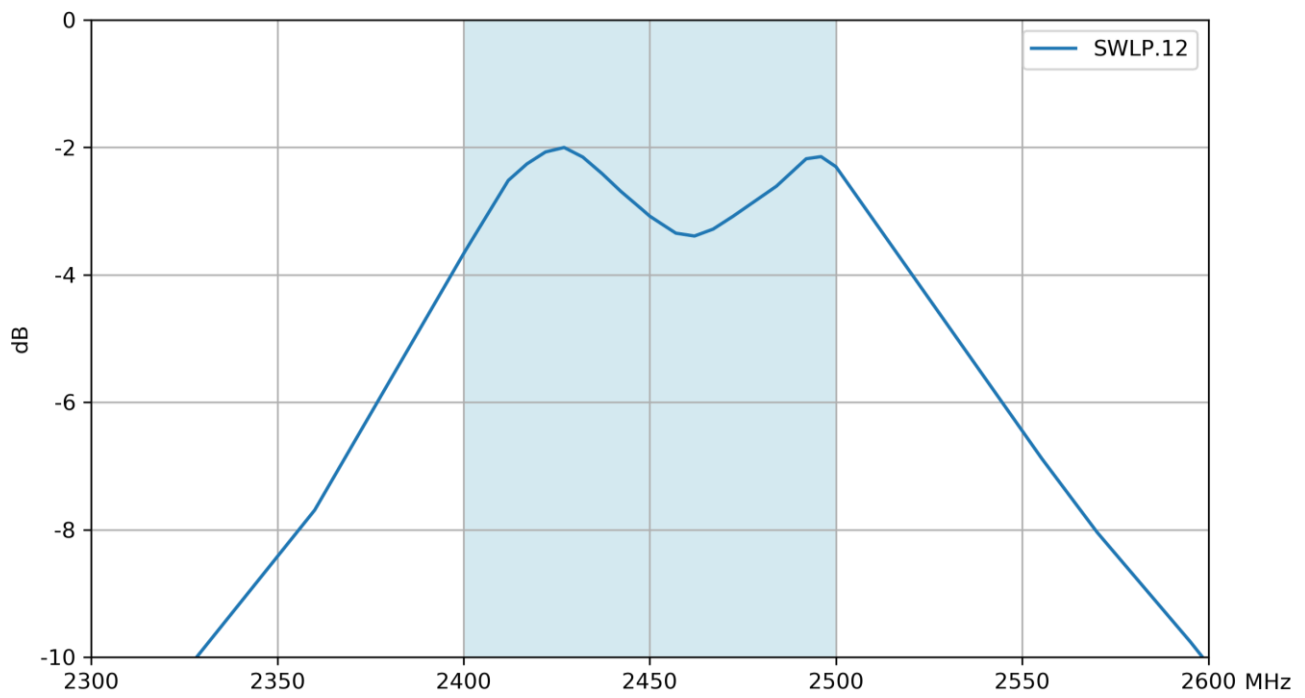

3.4 Peak Gain

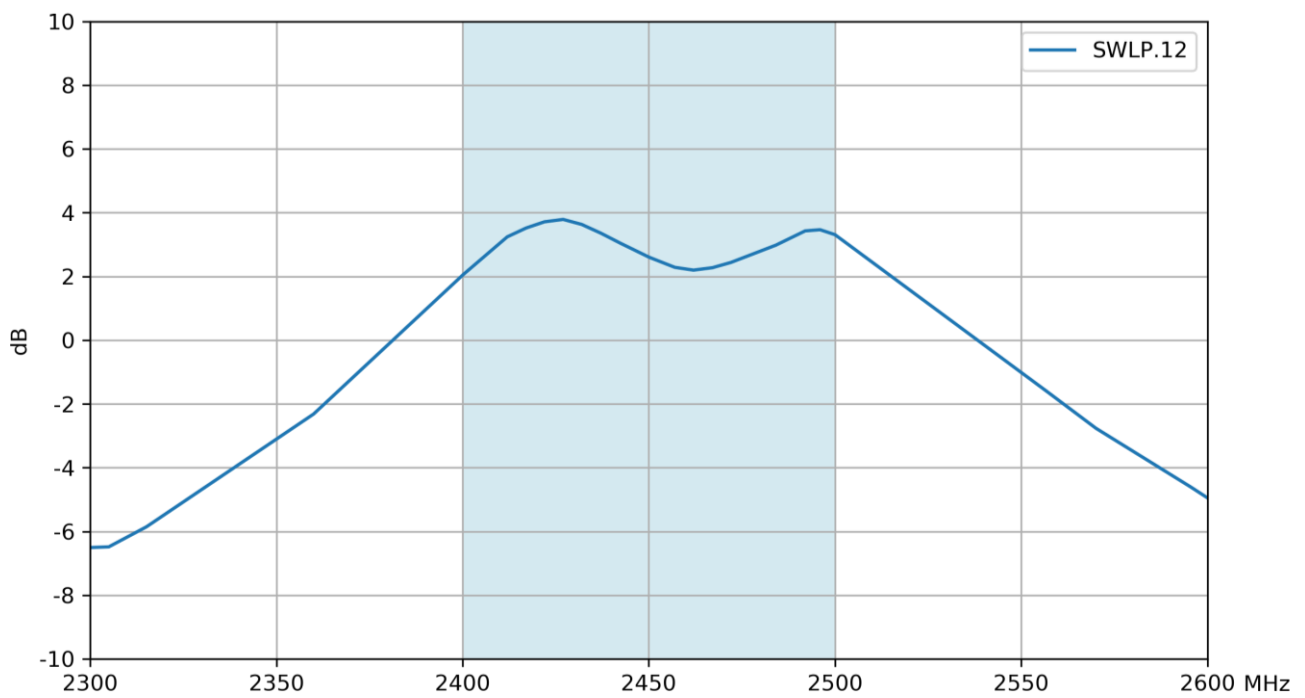

4. 2D Radiation Patterns

4.1 Test Setup

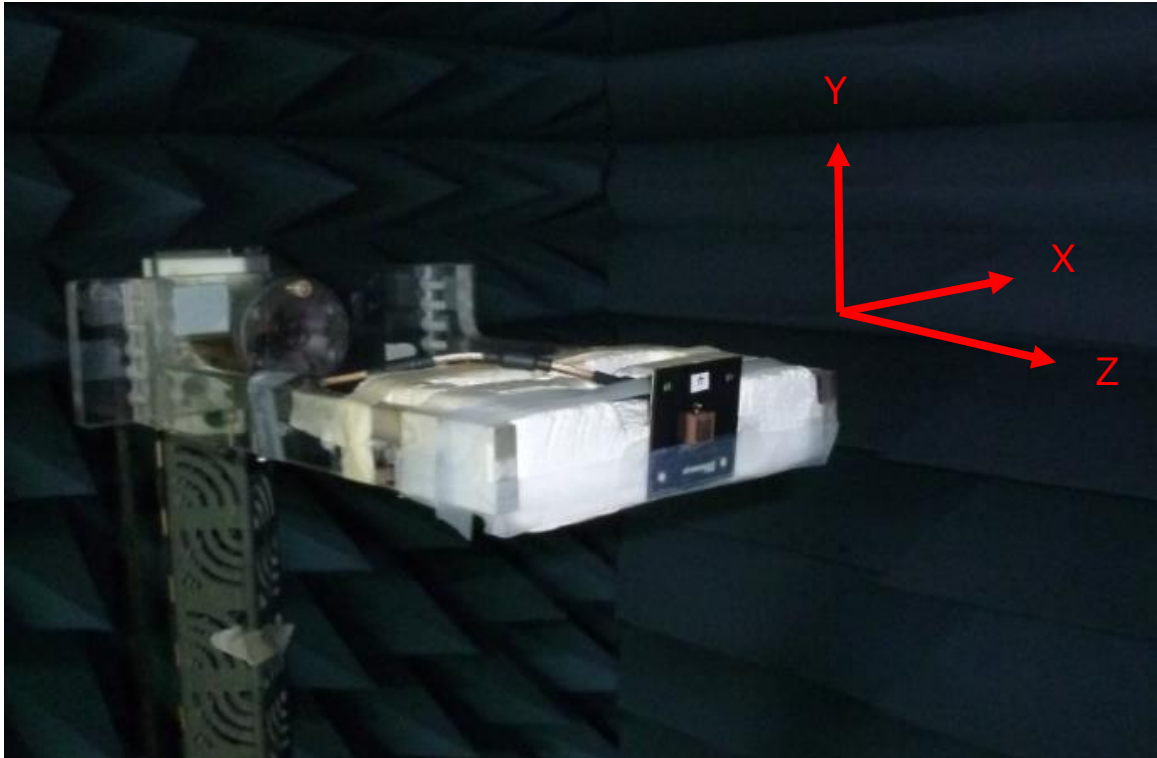

On Evaluation Board

XY Plane

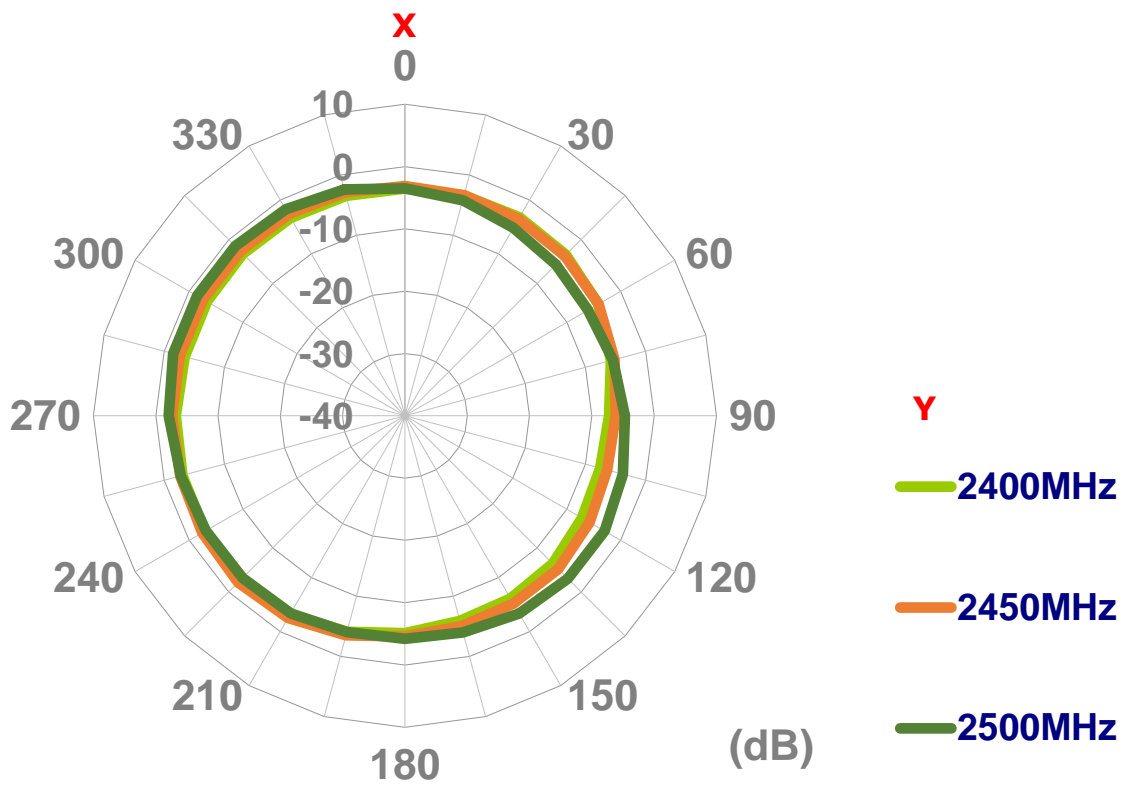

XZ Plane

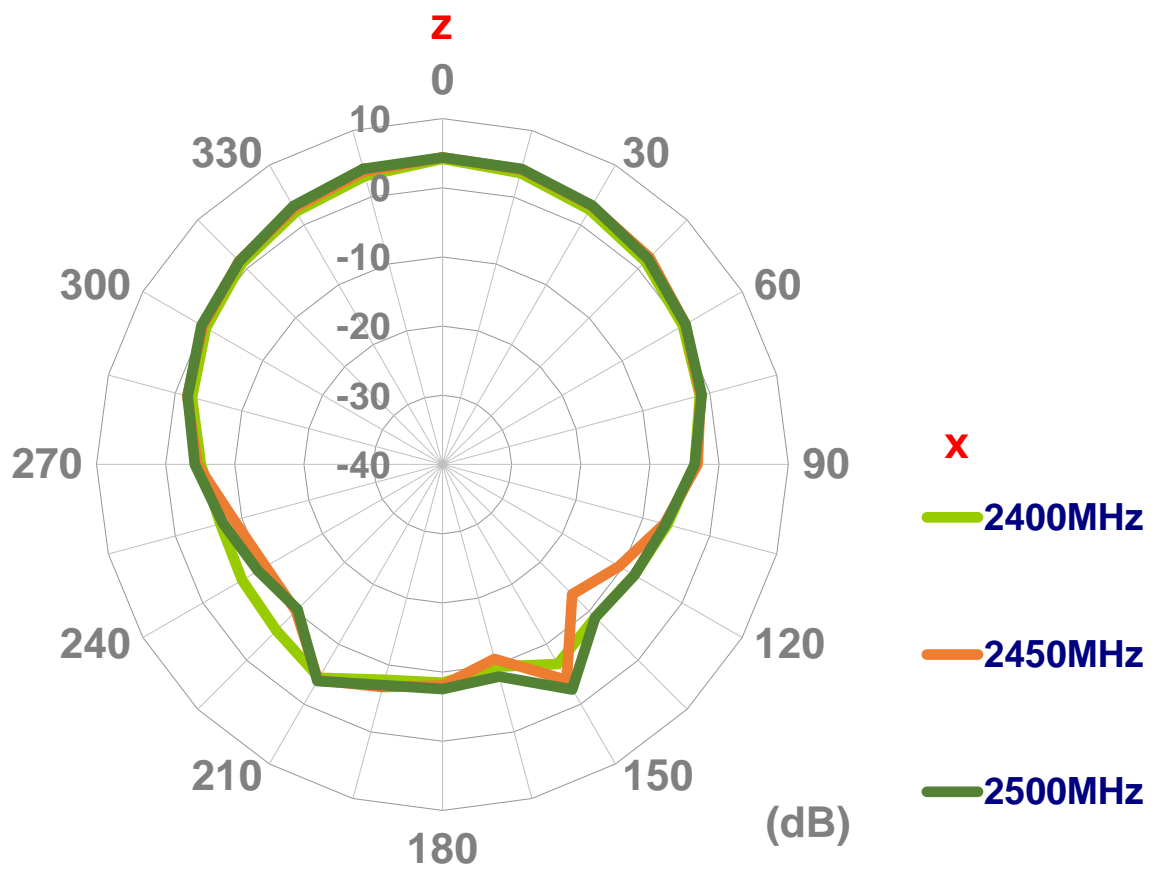

YZ Plane

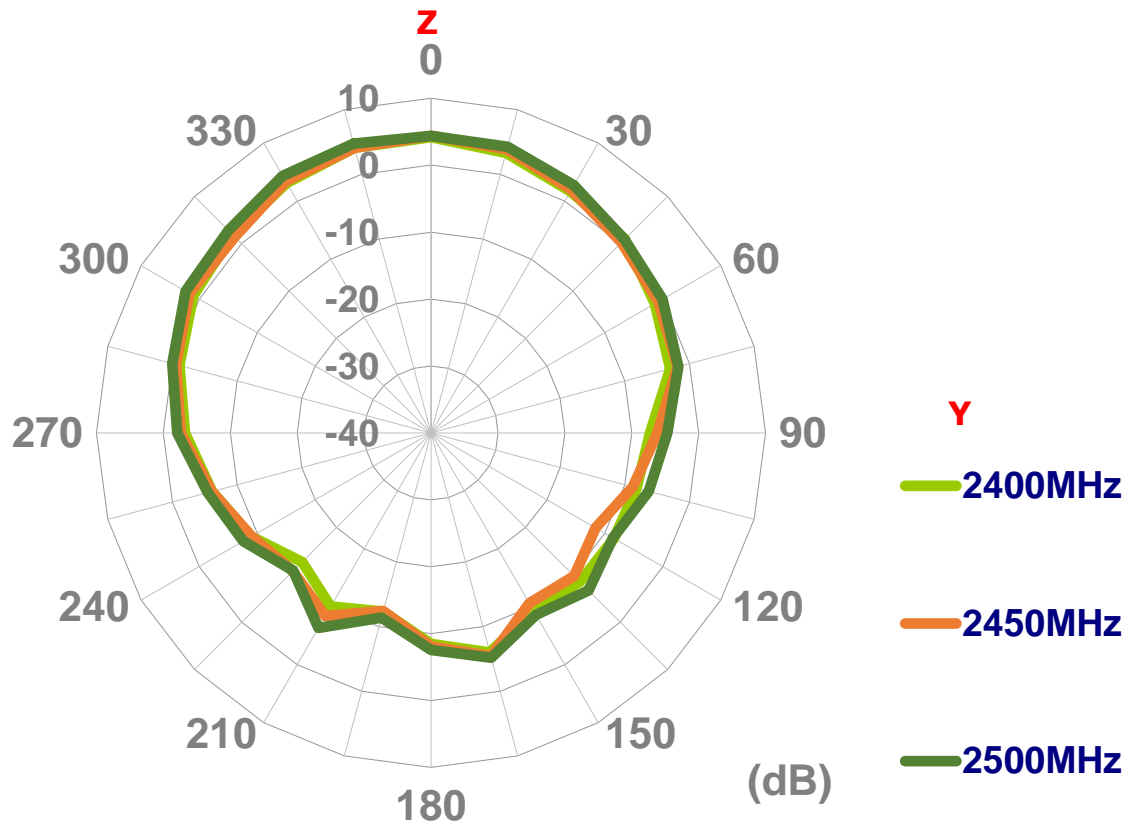

5. 3D Radiation Patterns

5.1 Free Space

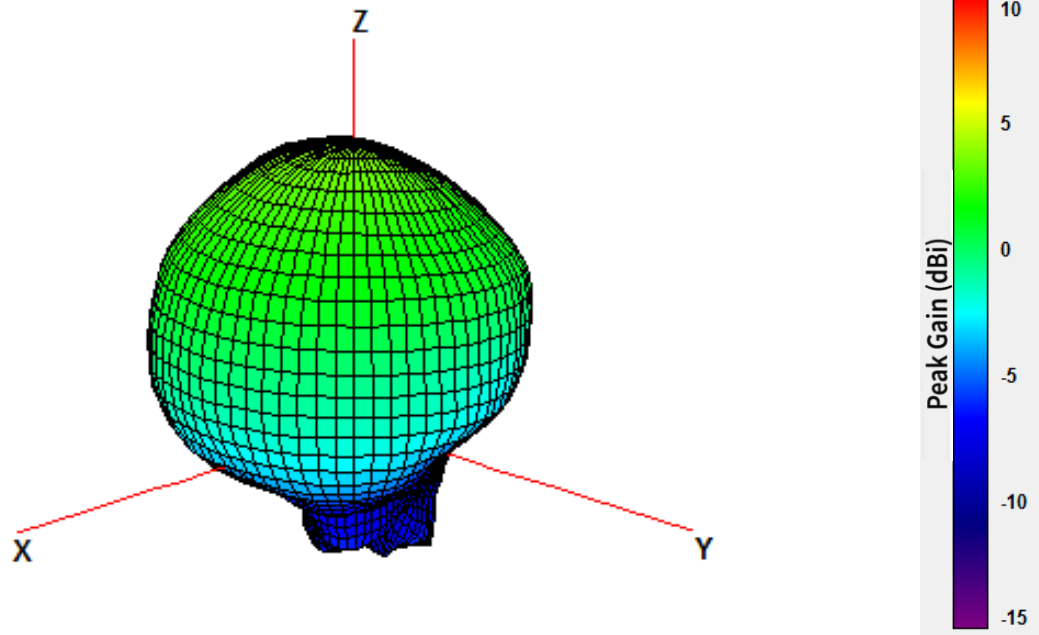

2400MHz

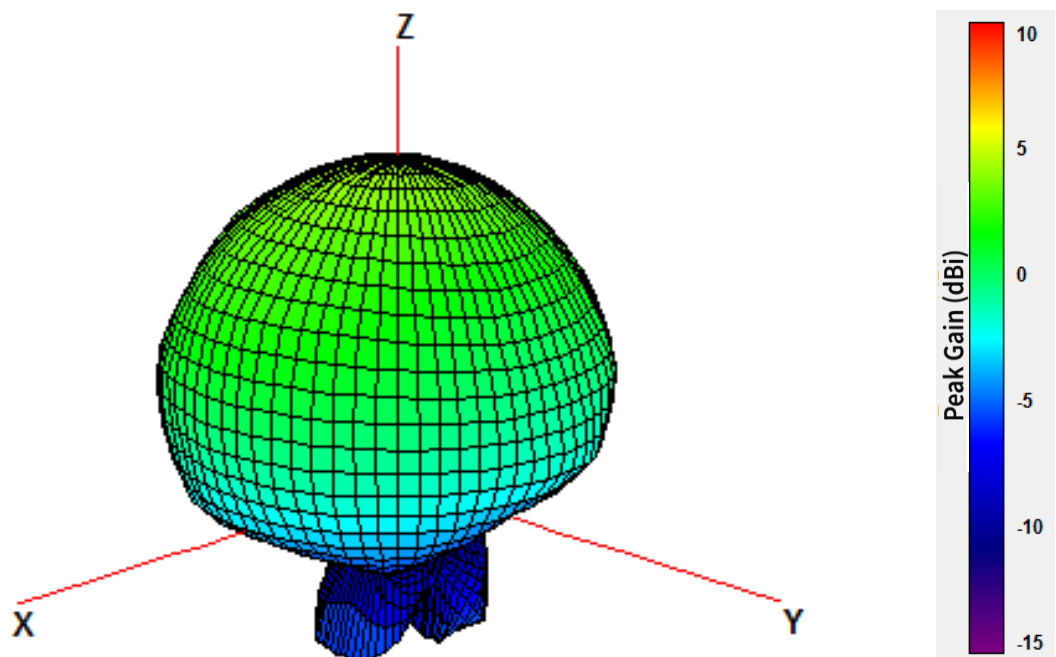

2450MHz

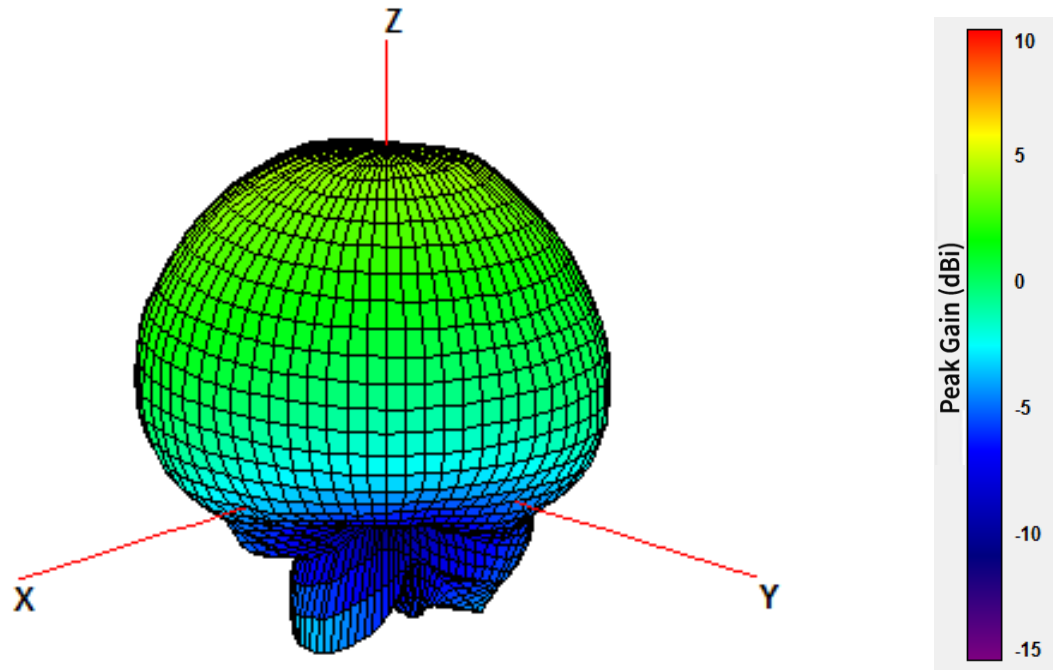

2500MHz

6. Mechanical Drawing (Units: mm)

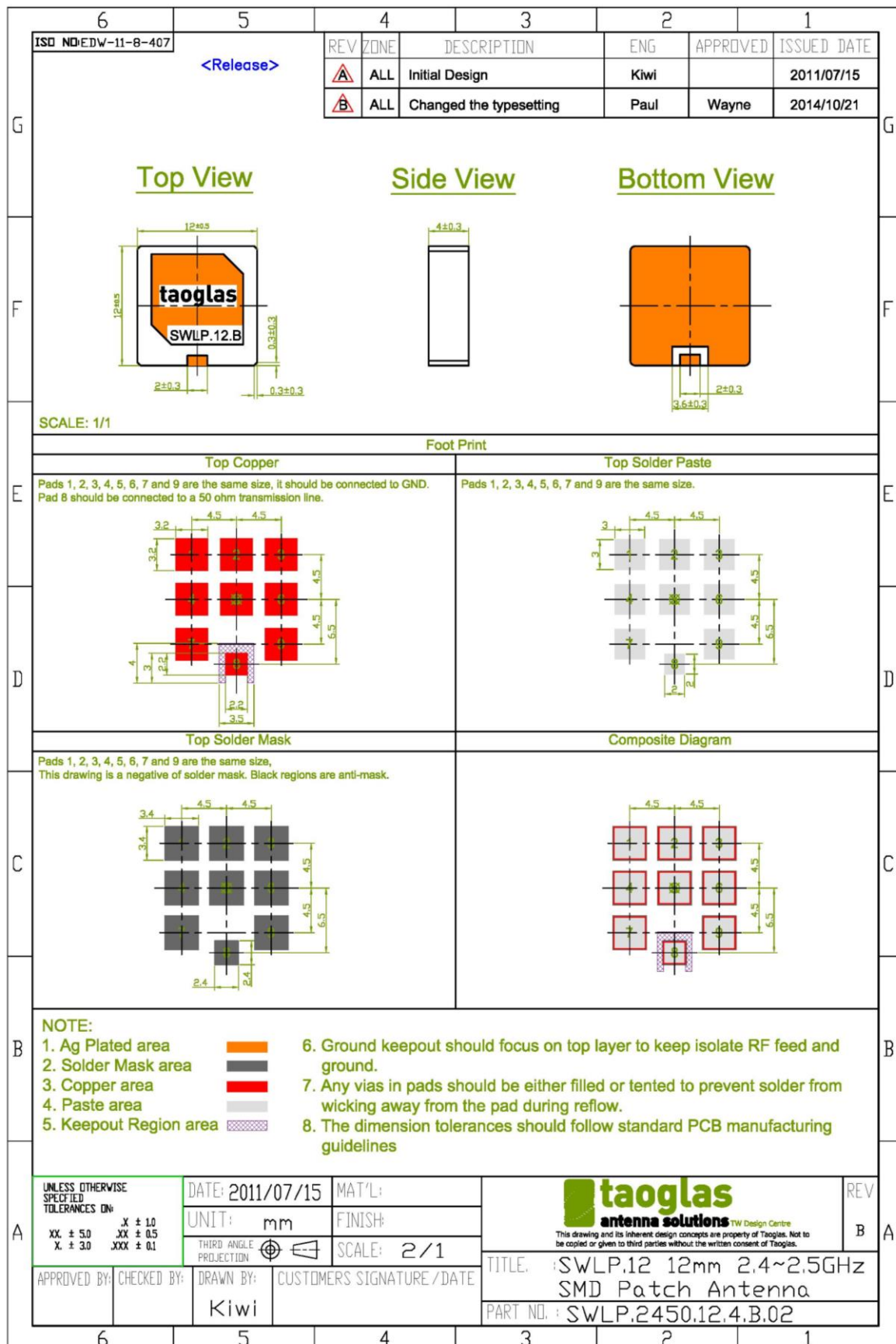

7. Evaluation Board

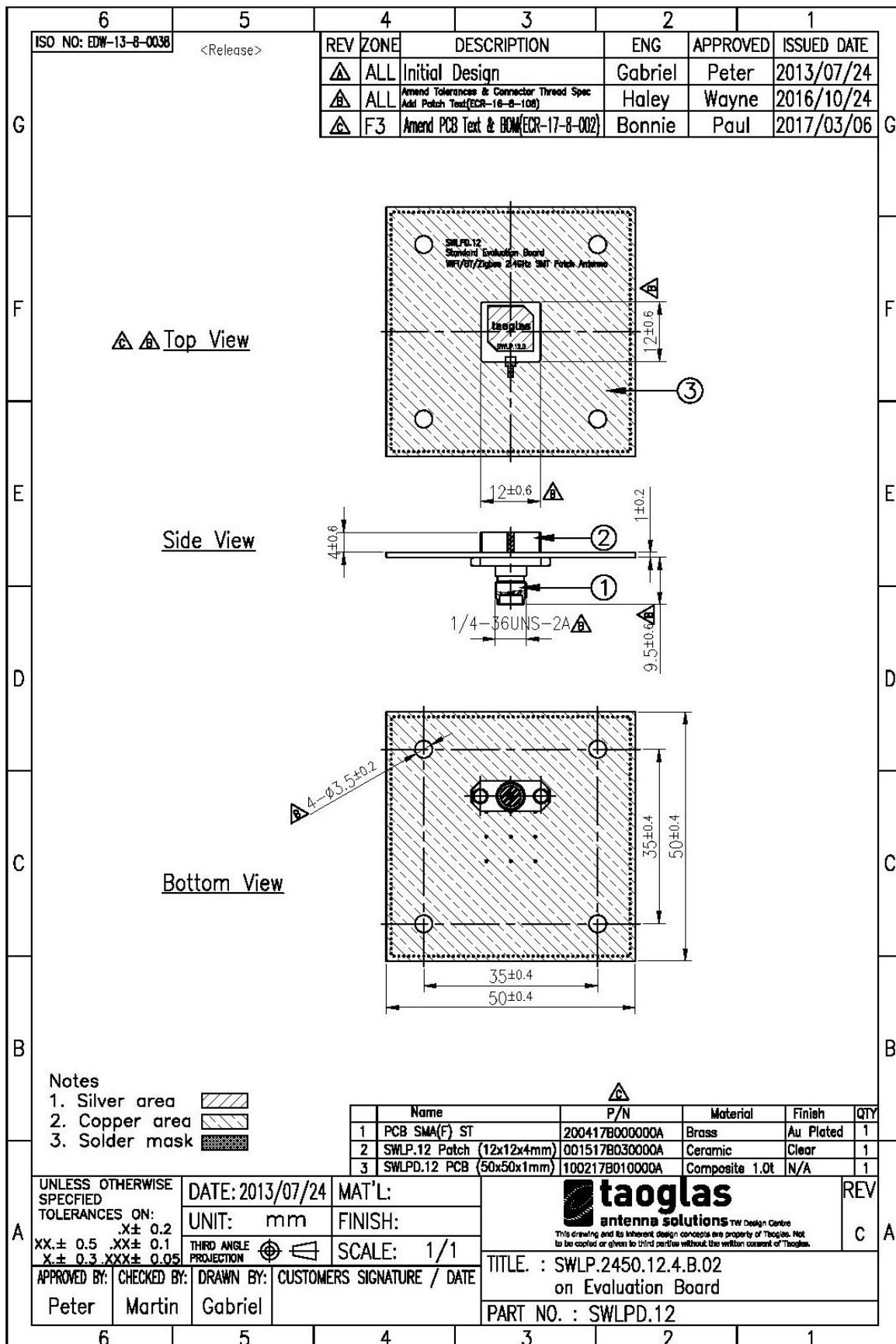

8. Packaging

500pcs SWLP.2450.12.4.B.02 per Tape & Reel
 Dimensions - Ø330*50mm
 Weight - 1.8Kg

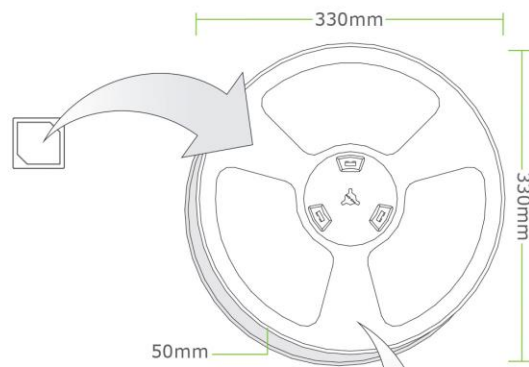

500pcs per Small Carton
 Carton Dimensions - 304*306*75mm
 Weight - 2.1Kg

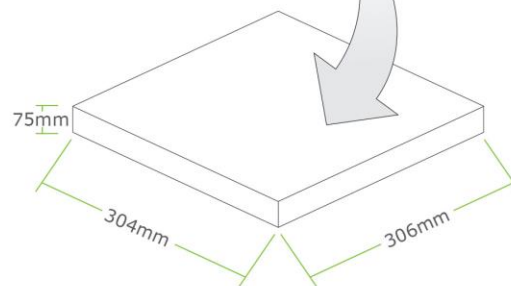

2000pcs per Large Carton
 Carton Dimensions - 370*360*305mm
 Weight - 9.3Kg

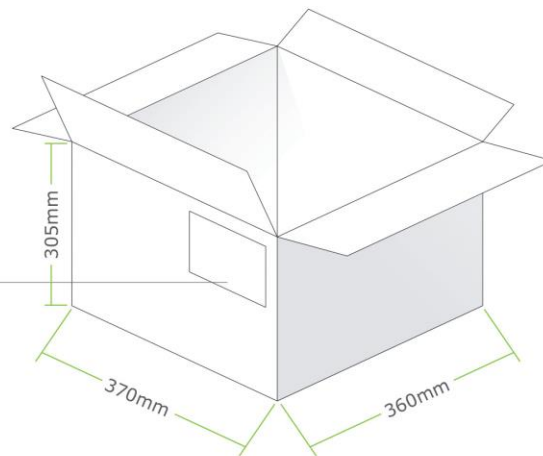
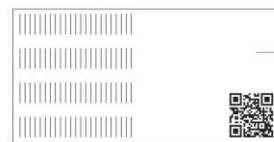

Pallet Dimensions 1200*1000*1440mm
 24 Cartons per Pallet
 6 Cartons per layer
 4 Layers

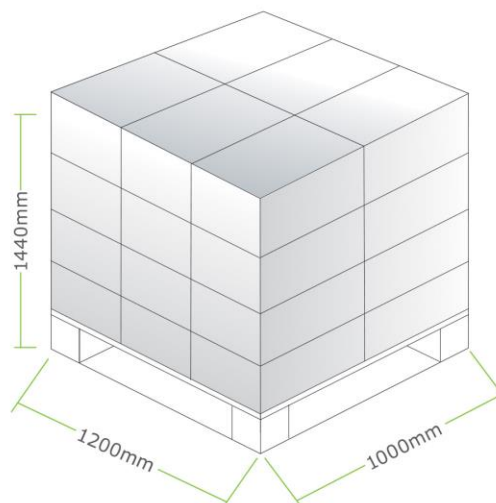

Changelog for the datasheet

SPE-13-8-007 – SWLP.2450.12.4.B.02

Revision: I (Current Version)	
Date:	2019-11-25
Changes:	Updated graphs based on new data
Changes Made by:	Jack Conroy

Previous Revisions



TAOGLAS®

www.taoglas.com

