

# SPECIFICATION

## PATENT PENDING

Model No. : **SGGP.18A**

Product Name : GPS/GLONASS/GALILEO SMT Patch Antenna

Features : Single Feed SMT  
GPS/GALILEO: 1575MHz  
GLONASS: 1602MHz  
Dims: 18\*18\*4mm  
RoHS Compliant



# 1. Introduction

This ceramic 18mm GPS/GLONASS/GALILEO patch antenna is mounted via SMT process and has been pre-tuned for a 50\*50mm ground plane. Custom part numbers tuned for different ground-plane or layout positions and taking into account the specific conditions in your device can be created and supplied by Taoglas.

# 2. Specification

Original Patch Specification tested on 50\*50mm ground plane

No	Parameter	Specification	Notes
1	Range of Receiving Frequency	GPS/GALILEO: 1575.42 MHz ± 1.023 MHz GLONASS: 1602± 5 MHz	
2	Return Loss	< -10dB	Center Frequency
3	Gain at Zenith	GPS: 3.88dBi GLONASS: 4.03 dBi	
4	Efficiency	GPS/GALILEO: 76.54% GLONASS: 78.59%	
5	Impedance	50 Ohms	
7	Frequency Temperature Coefficient ( τf )	0 ± 20ppm / oC	-40°C to +85°C
8	Operating Temperature	-40°C to +85°C	

\*\*Changes in user groundplane and environment will offset centre frequency

### 3. Electrical Specifications

#### 3.1. Return Loss

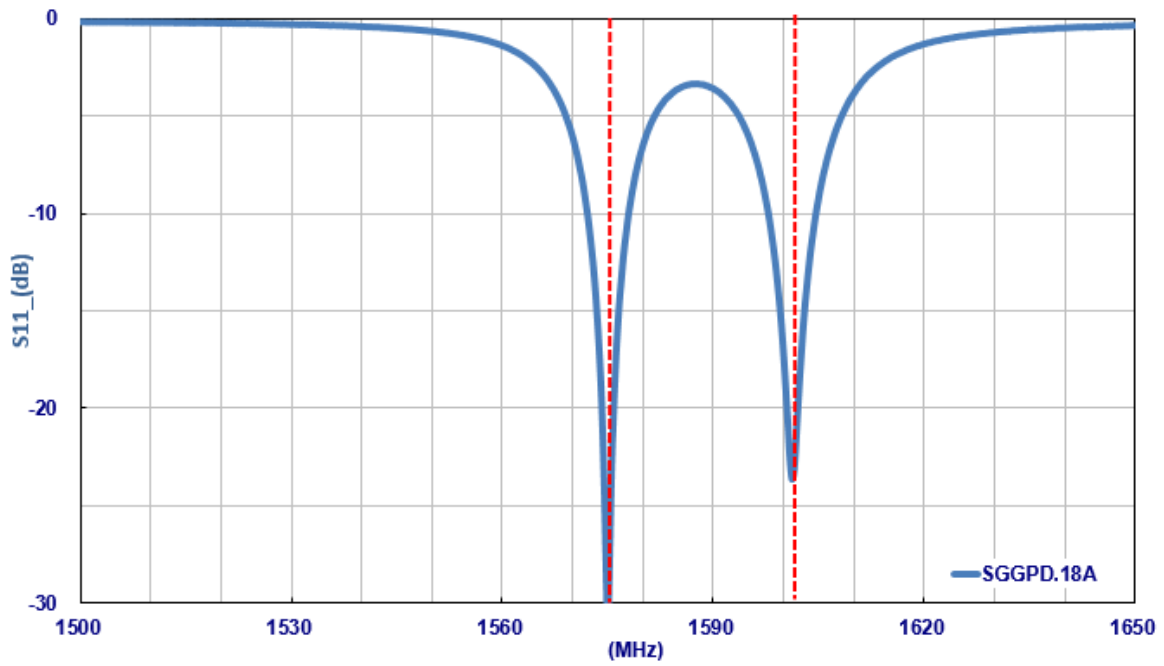

#### 3.2. Efficiency

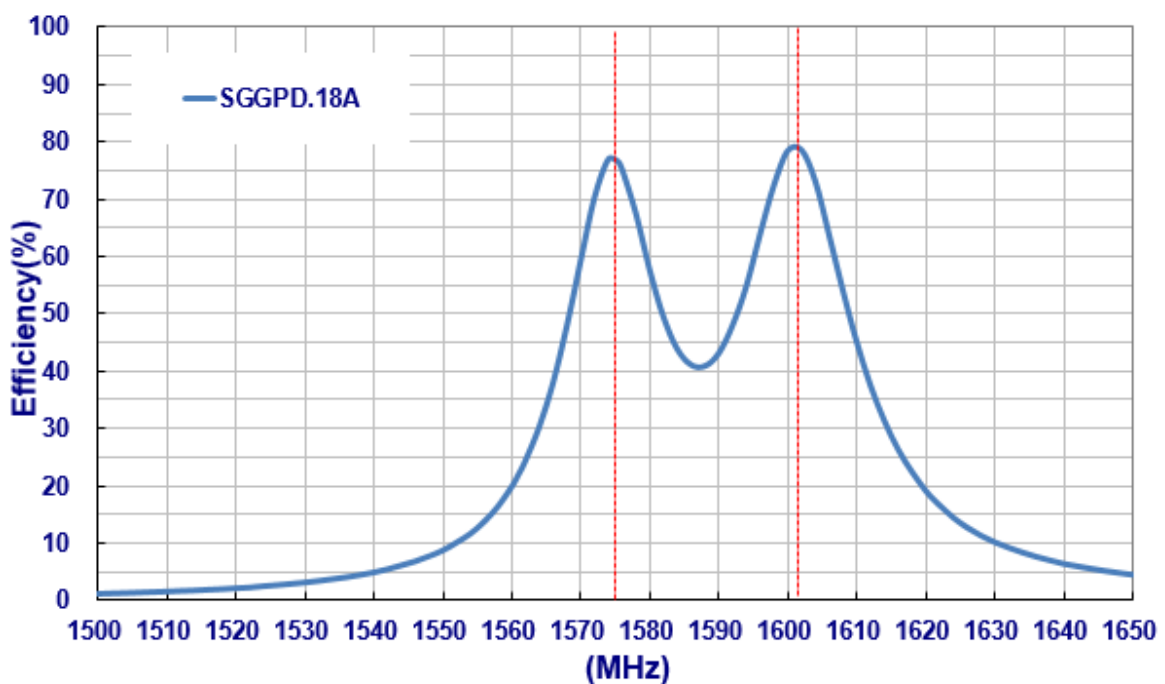

### 3.3. Average Gain

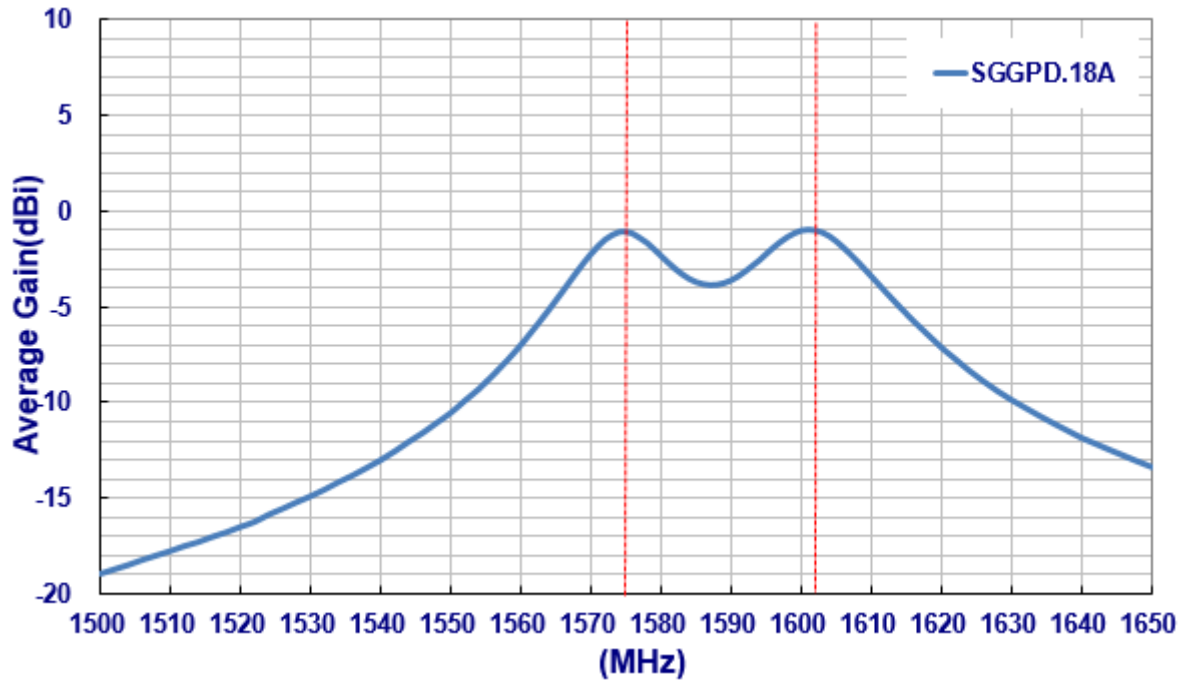

### 3.4. Peak Gain

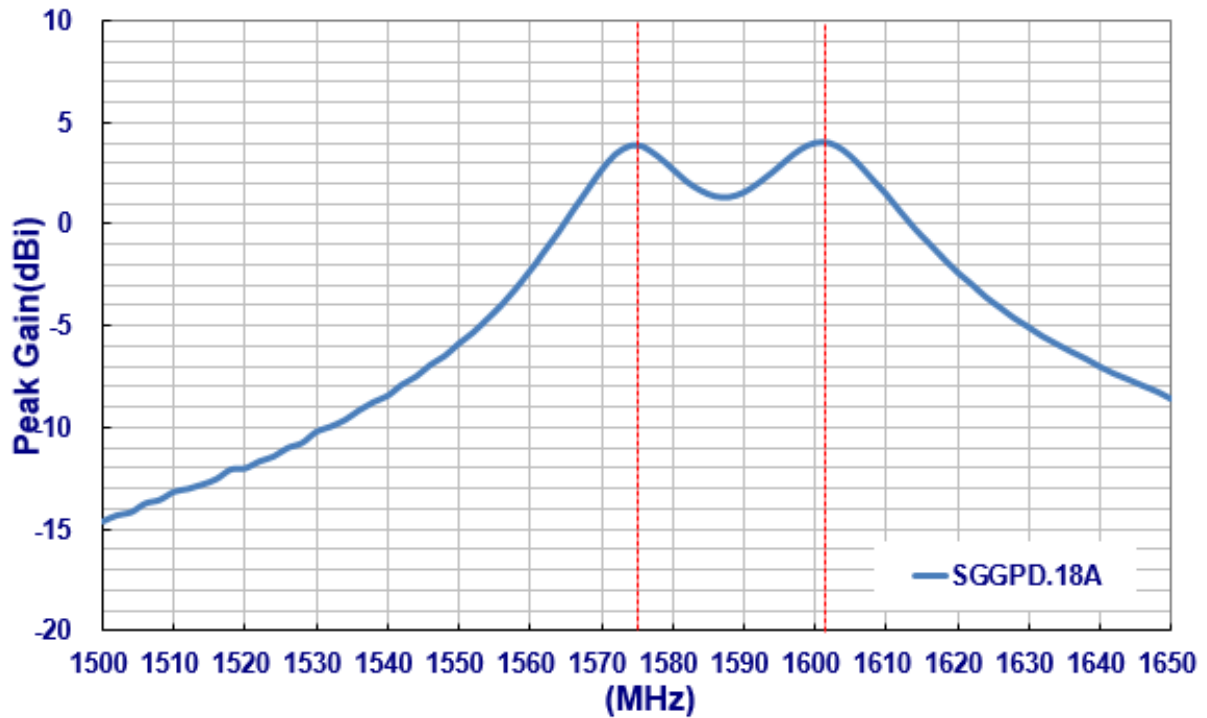

## 4. Radiation Patterns



### 4.1. XY Plane

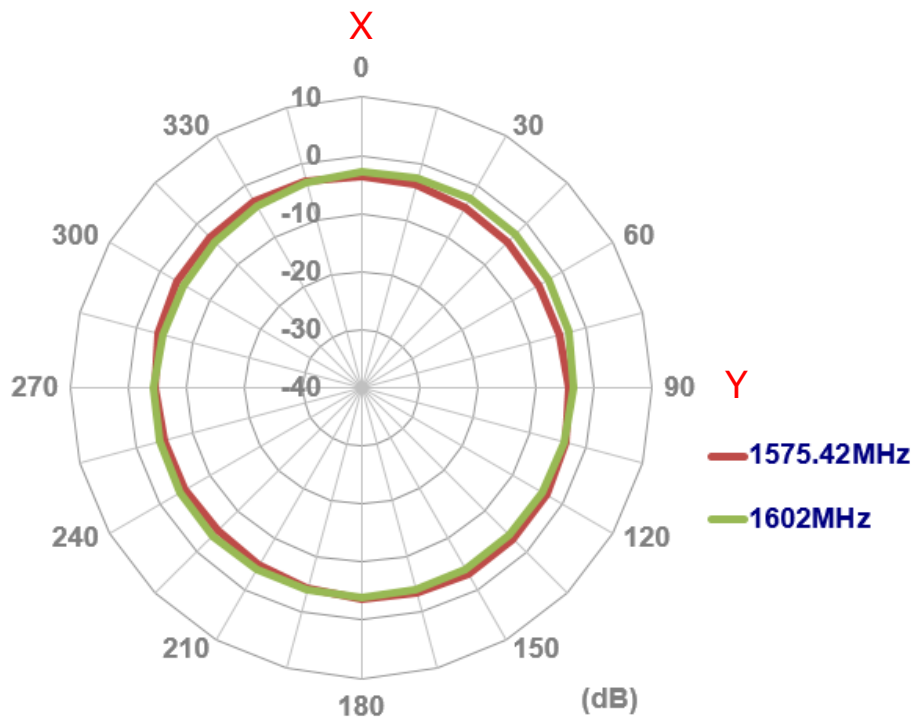

### 4.2. XZ Plane

Z

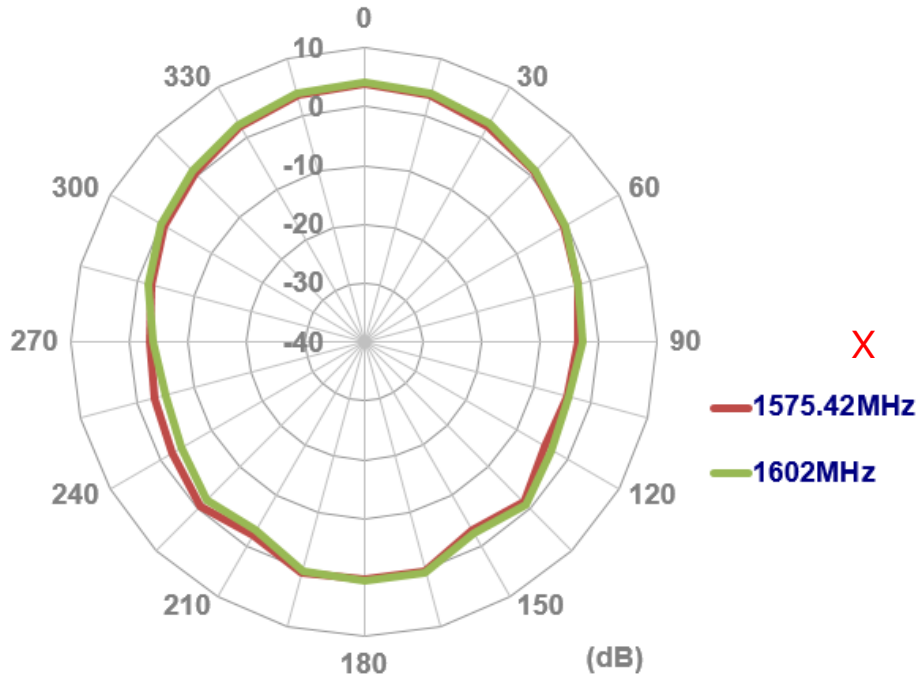

### 4.3. YZ Plane

Z

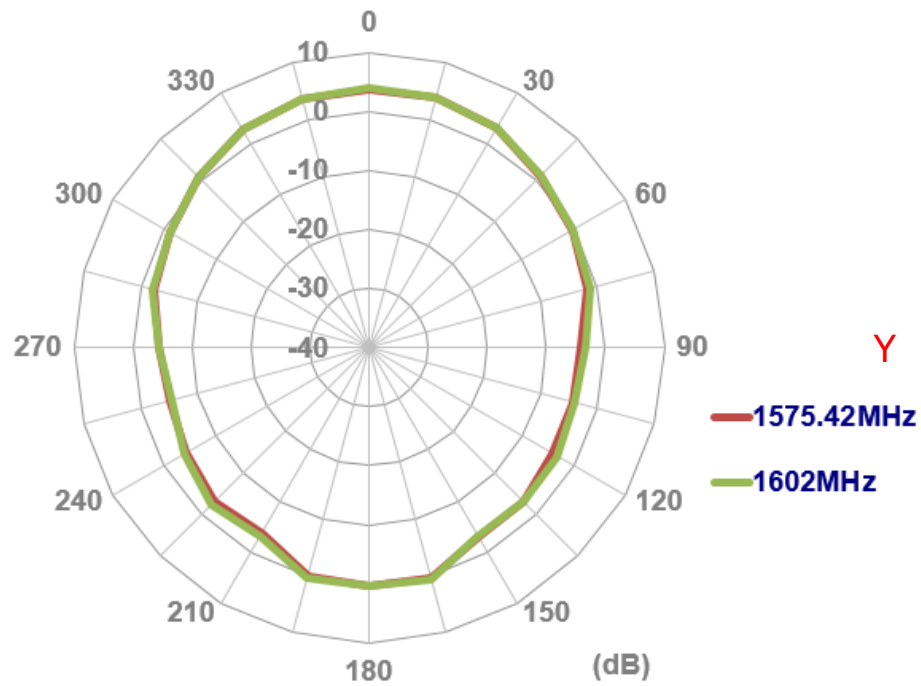

### 4.4. 3D Radiation Pattern

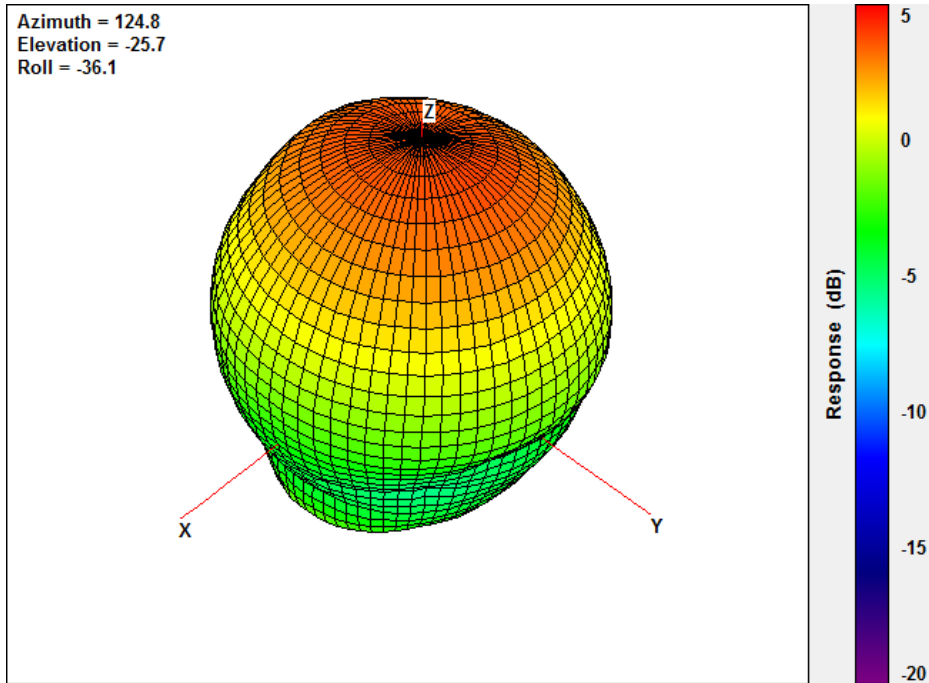

@ 1575.42MHz

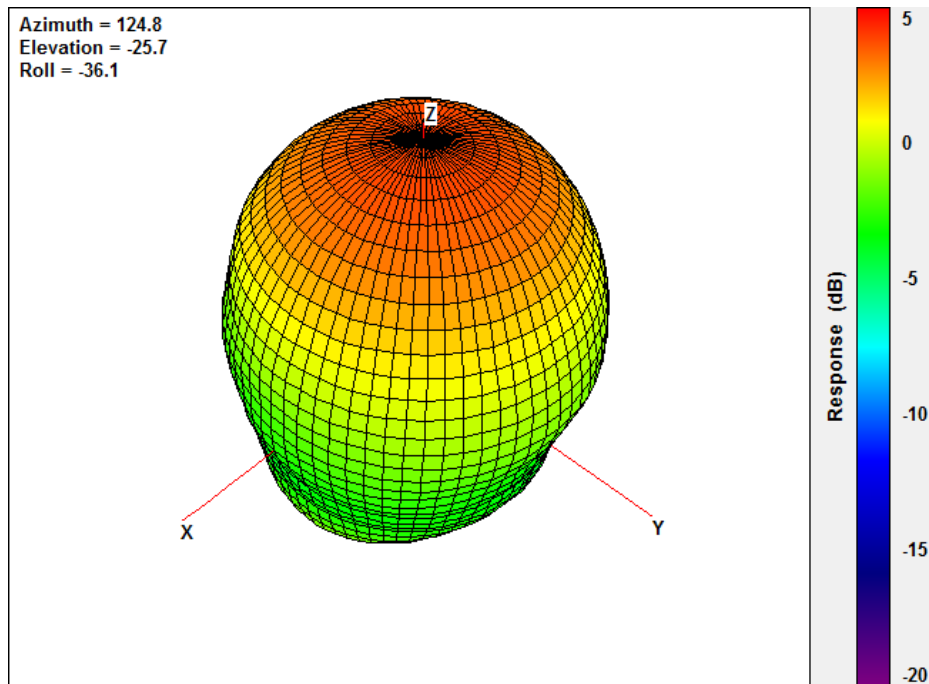

@ 1602MHz

## 5. Mechanical Specifications

### 5.1. Antenna Dimensions and Drawing

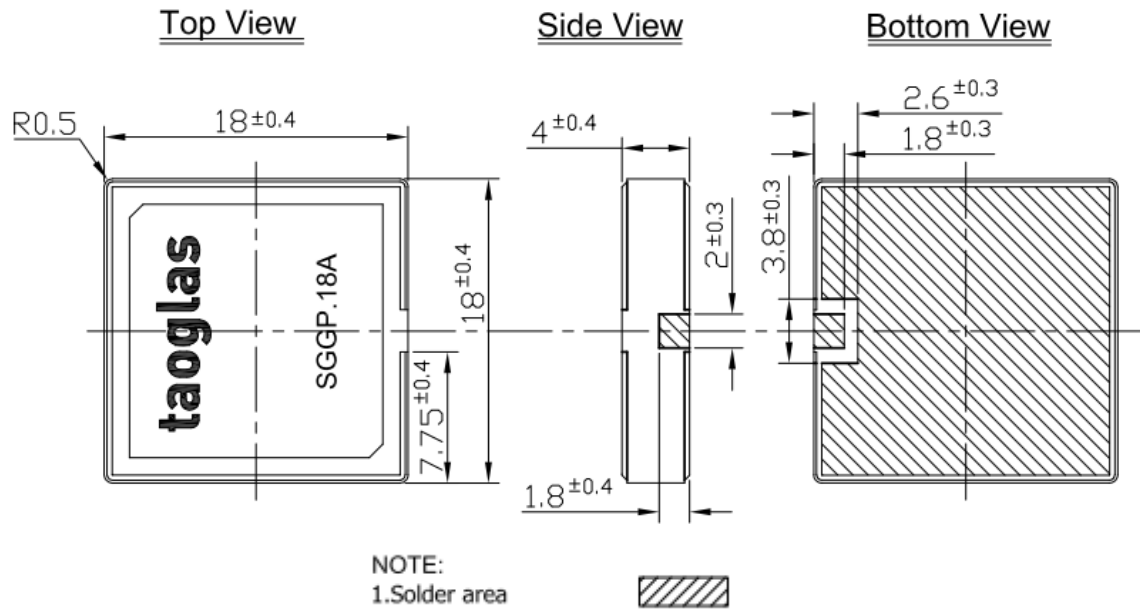



## 5.2. Top Copper and Copper Keepout

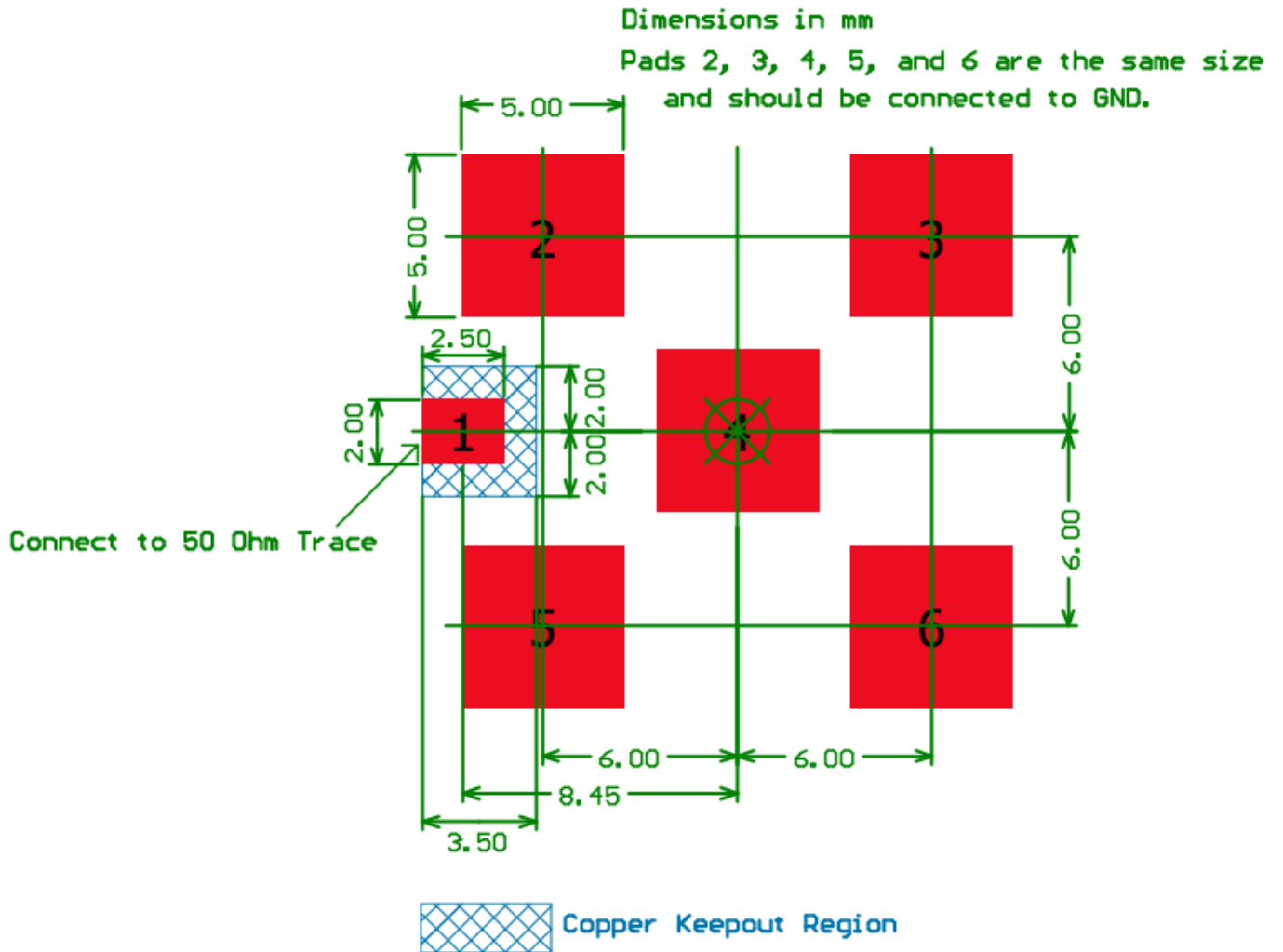

### 5.3. Solder Paste Area

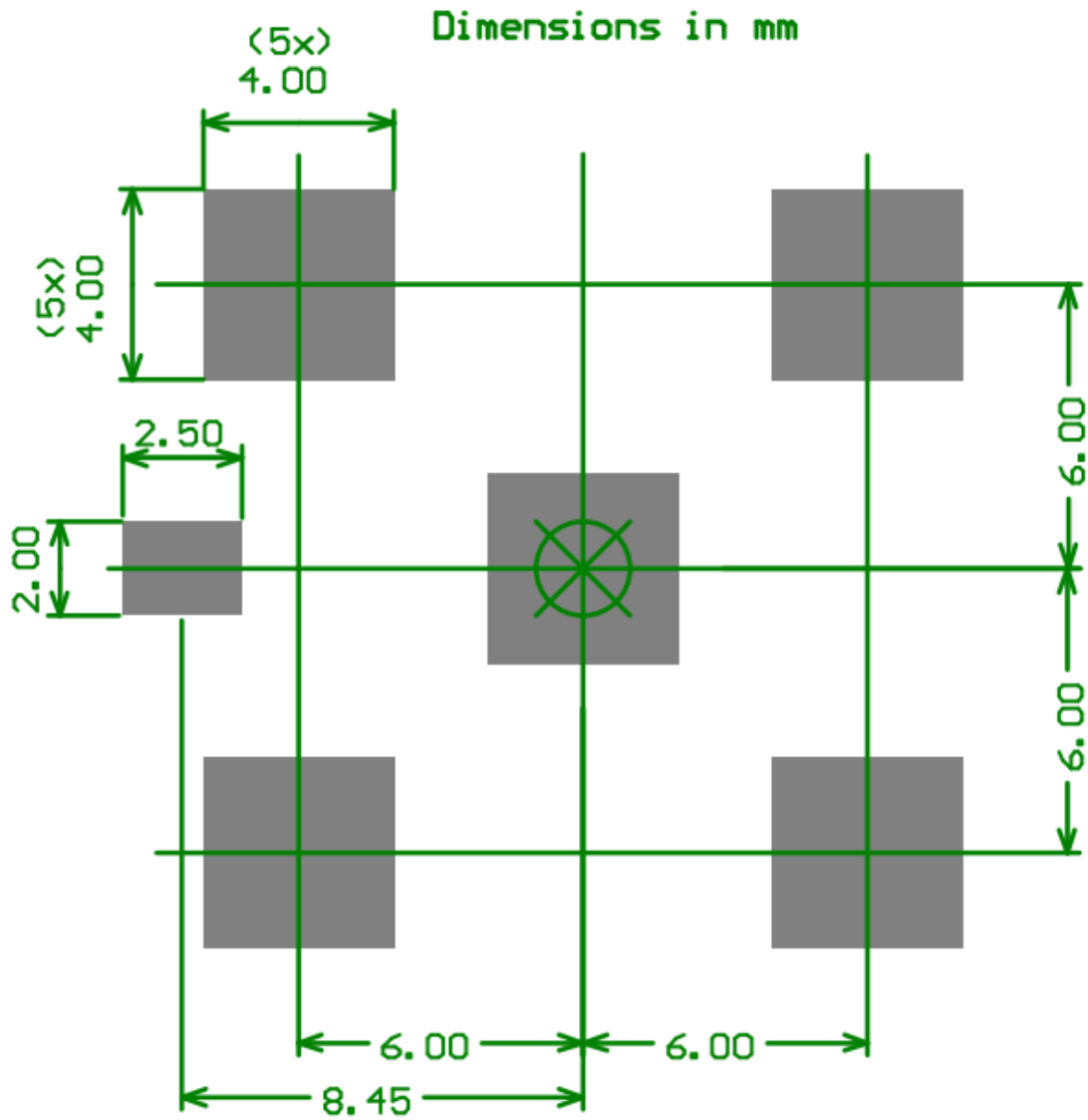

### 5.4. Solder Mask (Negative)

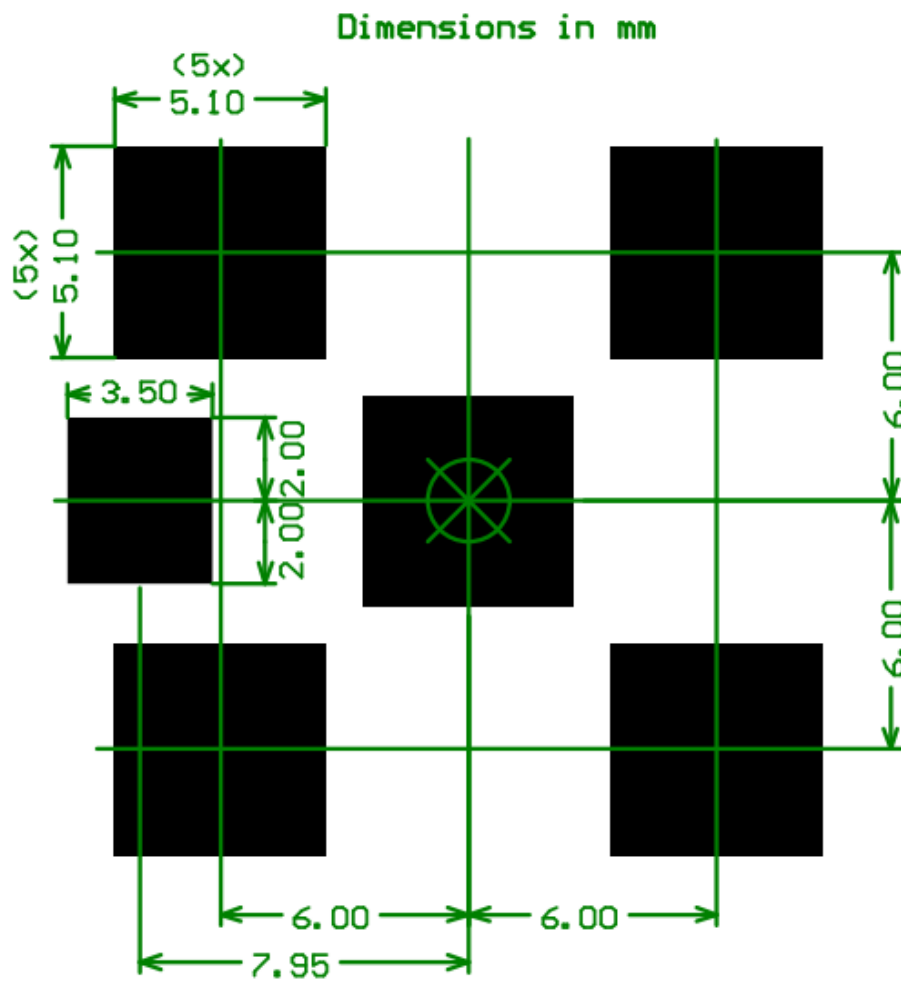

This drawing is a negative of solder mask.  
Black regions are anti-mask.

## 5.5. Footprint Composite

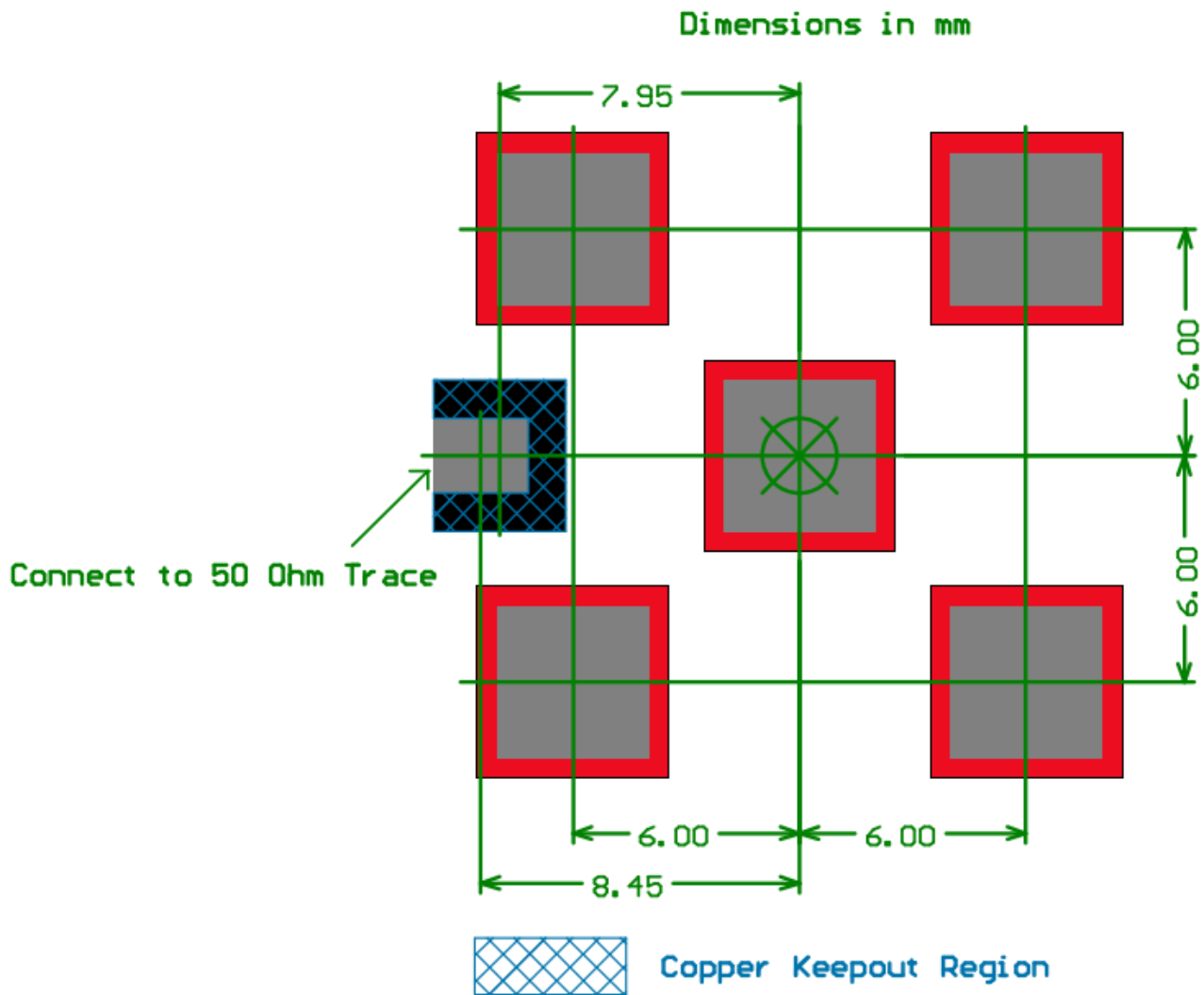

## 5.6. Evaluation Board

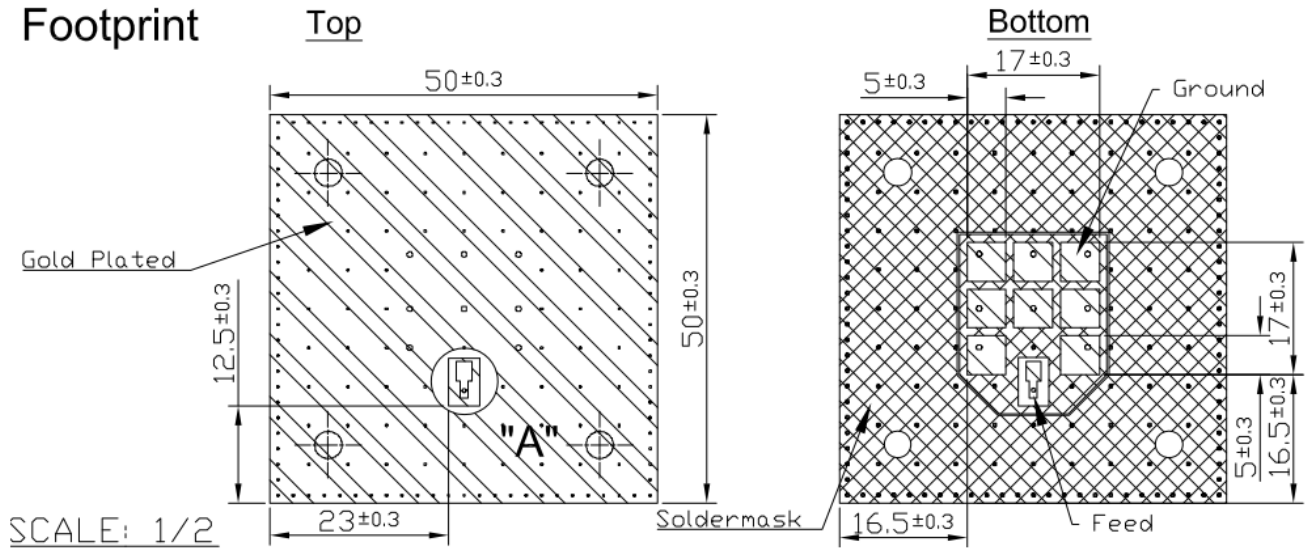

## 5.7. Feed

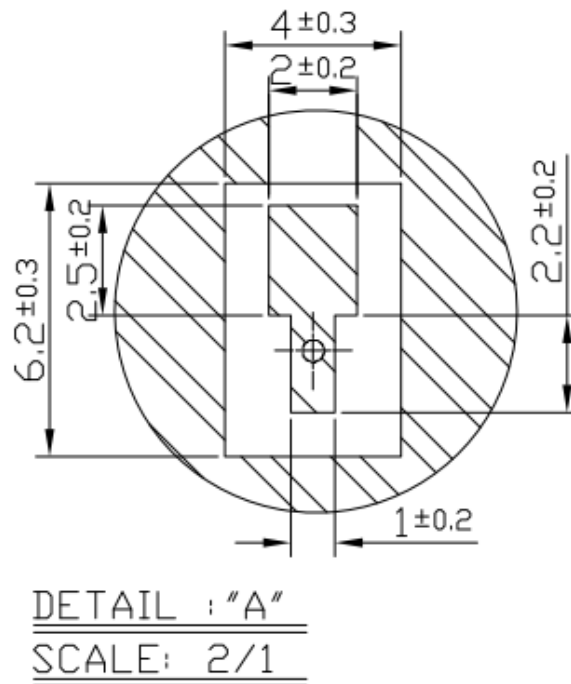

### 5.8. Test Jig and Dimension – SGGP.18A

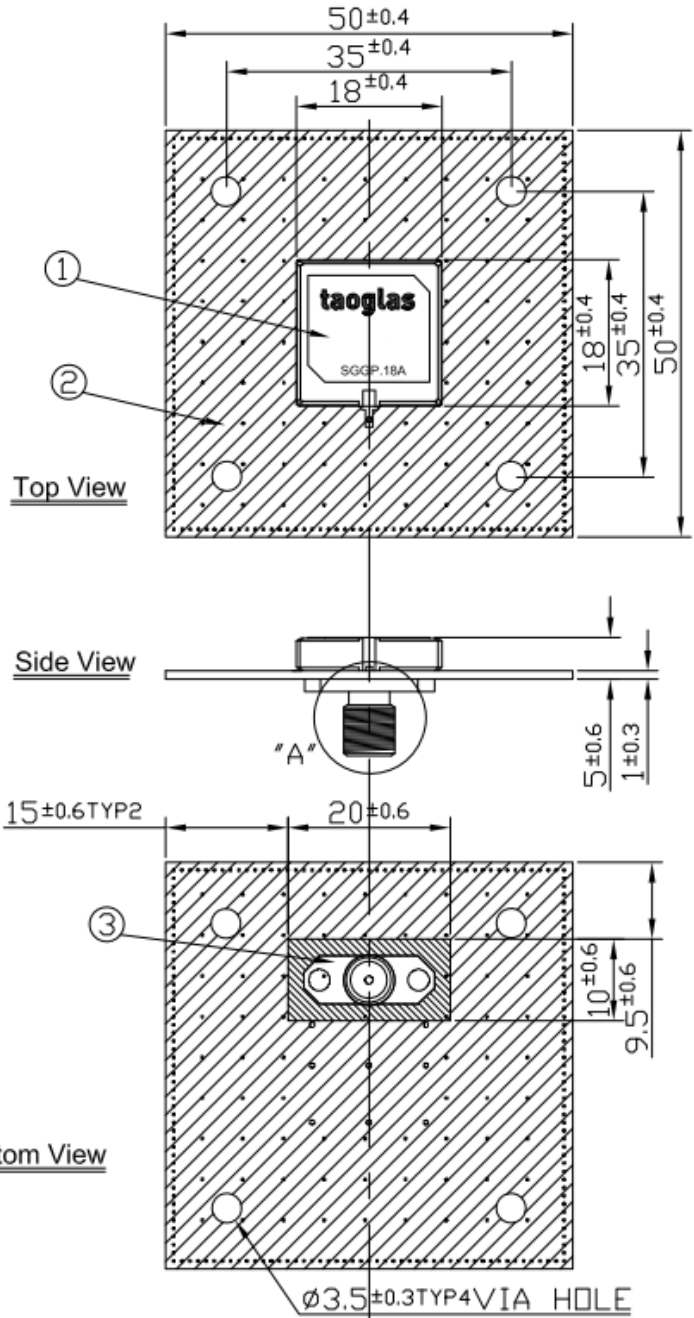
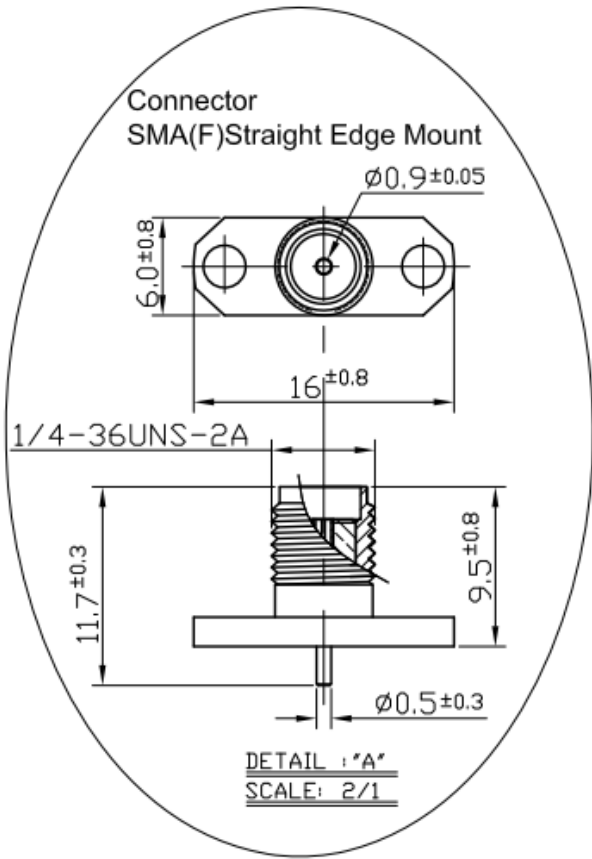

NOTES:

- 1. Solder Mask (Black) 
- 2. Solder Area 

	Name	Material	Finish	QTY
1	SGGP.18A Patch18x18x4	Ceramic	Clear	1
2	FR4 PCB	FR4 1t	Black	1
3	SMA(F) Straight Edge Mount	Brass	Gold	1

## 5.9. SGGPD.18A

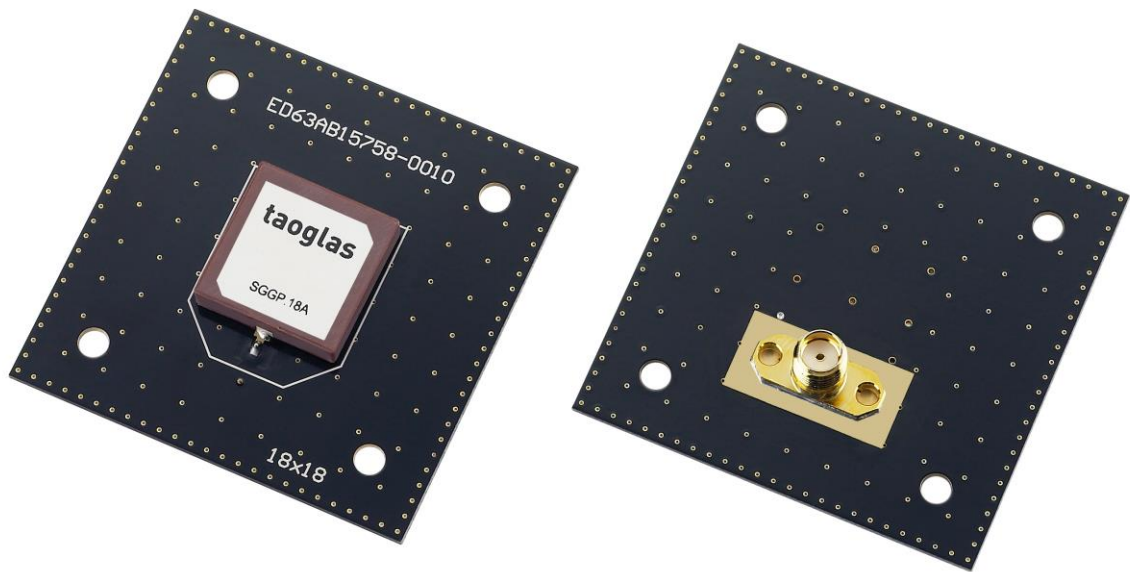

## 6. Antenna Recommended Soldering Conditions

### 6.1. Flux, Solder

- Use rosin-based flux. Don't use highly acidic flux with halide content exceeding 0.2wt%(chlorine conversion value).
- Use Sn solder.

### 6.2. Reflow soldering conditions

- Pre-heating should be in such a way that the temperature difference between solder and product surface is limited to 150°C max. Cooling into solvent after soldering also should be in such a way that temperature difference is limited to 100°C max. Unwrought pre-heating may cause cracks on the product, resulting in the deterioration of products quality.

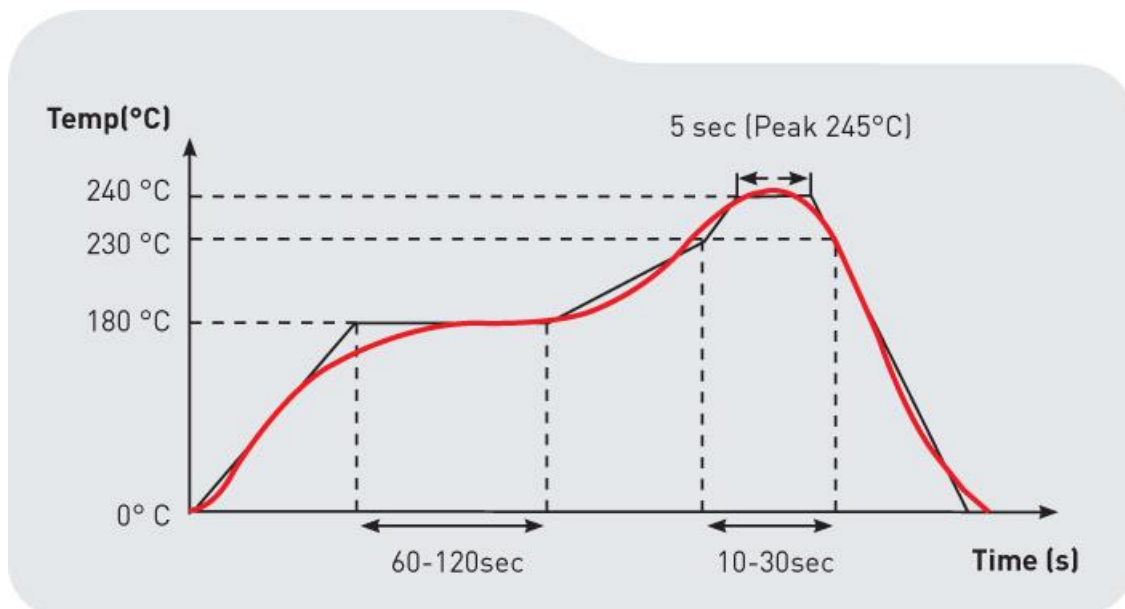



### 6.3. Reworking with soldering iron

- The following conditions must be strictly followed when using a soldering iron.

Pre-heating	150°C, 1 min
Tip temperature	290°C max
Soldering iron output	30w max
Soldering time	3 second max

## 7. Packaging

200 pcs/Reel/Inner Carton

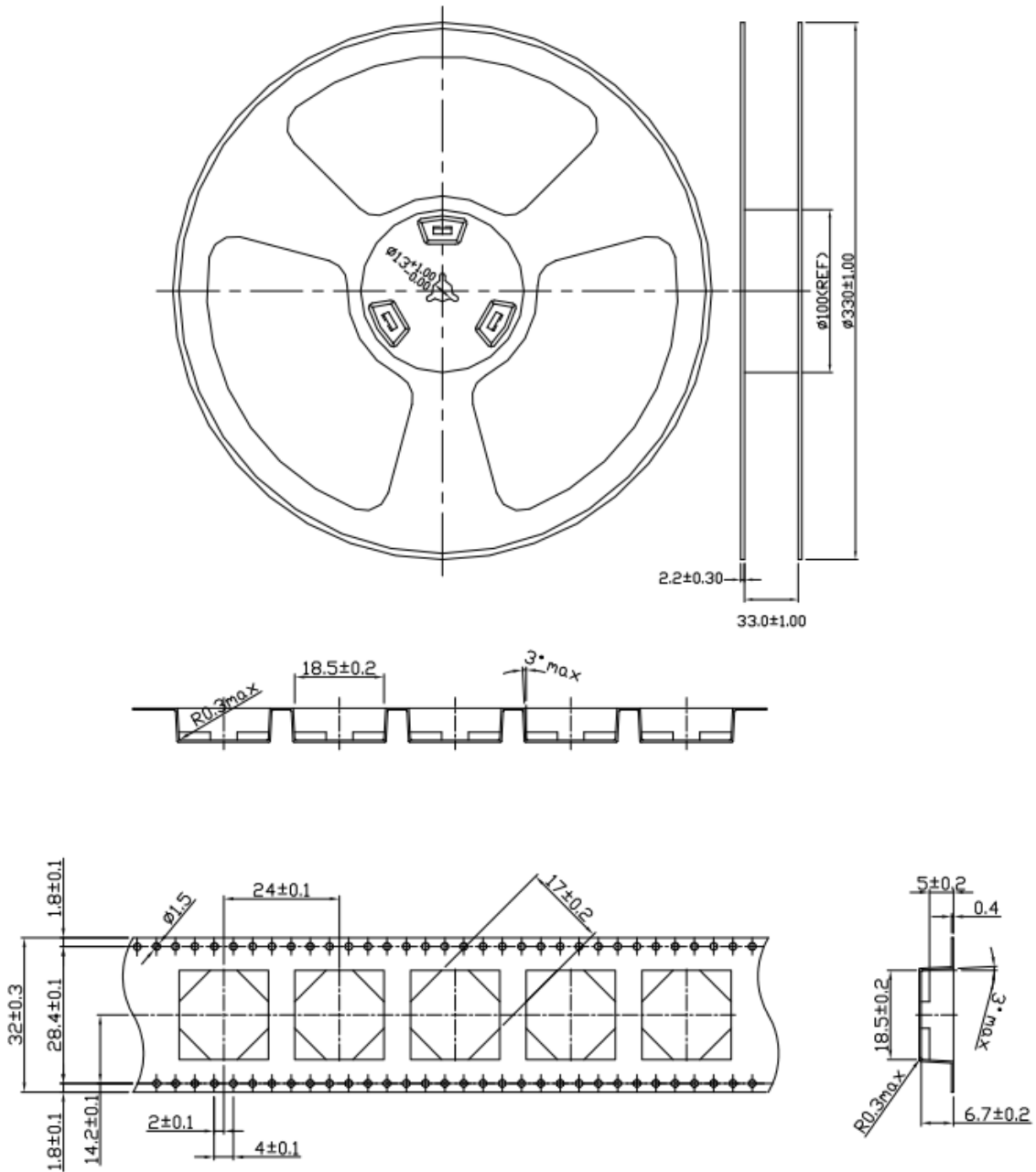

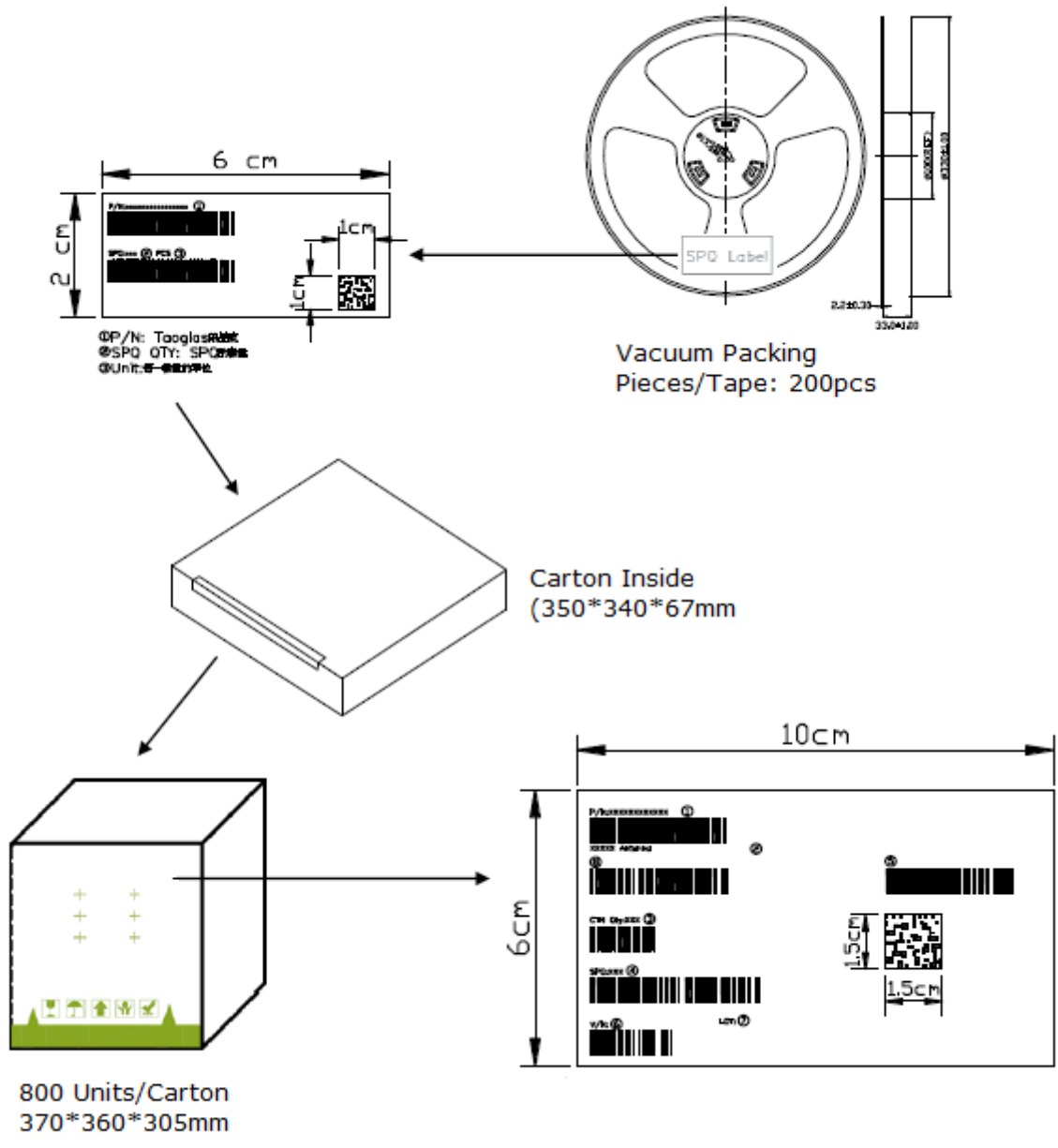

Taoglas makes no warranties based on the accuracy or completeness of the contents of this document and reserves the right to make changes to specifications and product descriptions at any time without notice. Taoglas reserves all rights to this document and the information contained herein.

Reproduction, use or disclosure to third parties without express permission is strictly prohibited.

Copyright © Taoglas Ltd.