

- ✧ Low forward voltage drop
- ✧ High surge current capability
- ✧ Meet MSL level 1, per J-STD-020D, lead free maximum peak of 260°C
- ✧ Plastic material used carriers Underwriters Laboratory Classification 94V-0
- ✧ Epitaxial construction
- ✧ High temperature soldering guaranteed: 260°C/10s at terminals
- ✧ Green compound with suffix "G" on packing code & prefix "G" on datecode

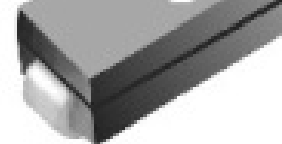

## Mechanical Data

- ✧ Case: Molded plastic
- ✧ Terminal: Matte tin plating
- ✧ Polarity: Indicated by cathode band
- ✧ Packaging: 12mm tape per EIA STD RS-481
- ✧ Weight: 0.066 gram

## Ordering Information (example)

Part No.	Package	Packing	Packing code	Green Compound Packing code
SSL12	SMA	1.8K / 7" REEL	R3	R3G

## Maximum Ratings and Electrical Characteristics

Rating at 25 °C ambient temperature unless otherwise specified.

Single phase, half wave, 60 Hz, resistive or inductive load.

For capacitive load, derate current by 20%

Type Number	Symbol	SSL12	SSL13	SSL14
Maximum Repetitive Peak Reverse Voltage	$V_{RRM}$	20	30	40
Maximum RMS Voltage	$V_{RMS}$	14	21	28
Maximum DC Blocking Voltage	$V_{DC}$	20	30	40
Maximum Average Forward Rectified Current	$I_{F(AV)}$	1		
Peak Forward Surge Current, 8.3 ms Single Half Sine-wave Superimposed on Rated Load	$I_{FSM}$	50		
Maximum Instantaneous Forward Voltage (Note 1) @ 1 A	$V_F$	0.39		
Maximum Reverse Current @ Rated VR $T_A=25\text{ }^\circ\text{C}$ $T_A=100\text{ }^\circ\text{C}$	$I_R$	0.2		
		50		
Typical Thermal Resistance	$R_{\theta JA}$	88		
	$R_{\theta JL}$	28		
Marking Code		SL12	SL13	SL14
Operating Temperature Range	$T_J$	- 55 to + 125		
Storage Temperature Range	$T_{STG}$	- 55 to + 150		

Note1: Pulse Test with PW=300u sec, 1% Duty Cycle

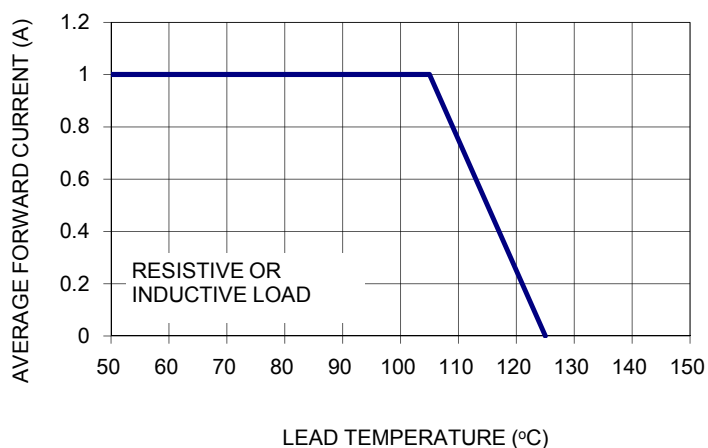

FIG. 3 TYPICAL FORWARD CHARACTERISTICS

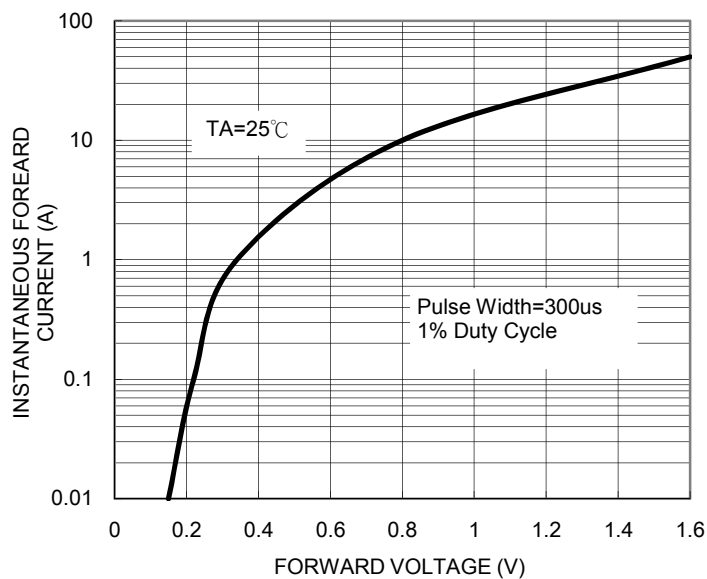

FIG. 5 TYPICAL JUNCTION CAPACITANCE

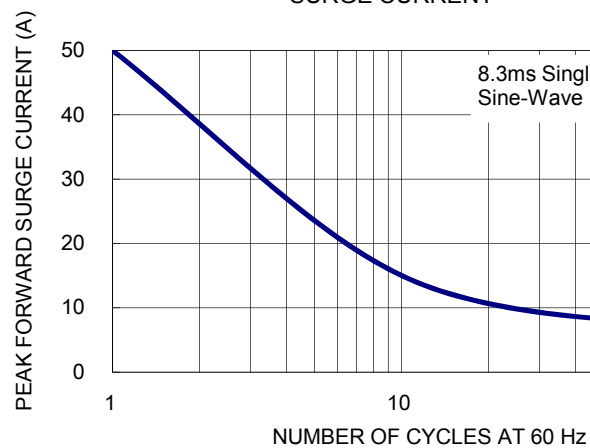
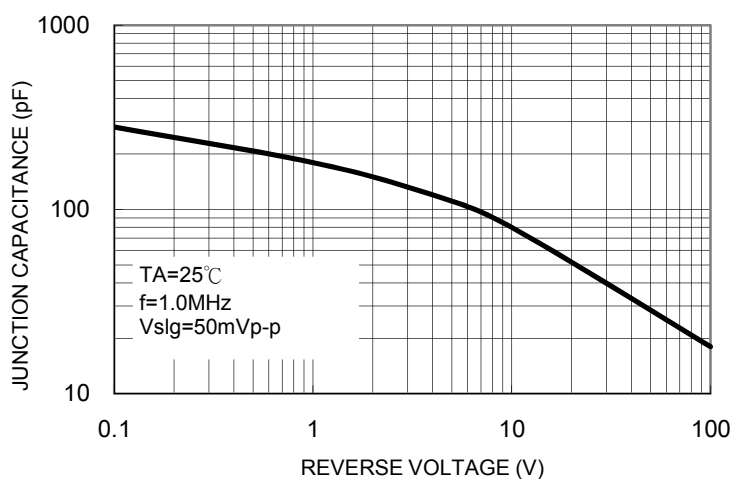
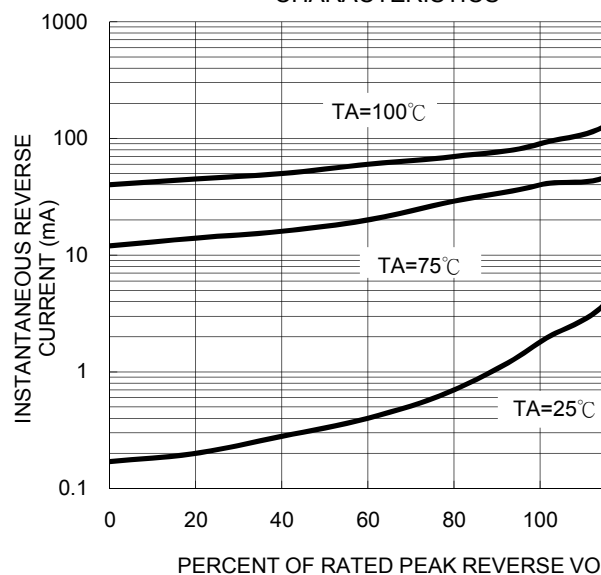

FIG. 4 TYPICAL REVERSE CHARACTERISTICS



SSL1X (Note)	Folded SMA	1.8K / 7" REEL	F3	F3G
	Folded SMA	7.5K / 13" REEL	F2	F2G
	C SMA	1.8K / 7" REEL	E3	E3G
	C SMA	7.5K / 13" REEL	E2	E2G

Note: "x" is Device Code from "2" thru "4".

### Tape & Reel specification

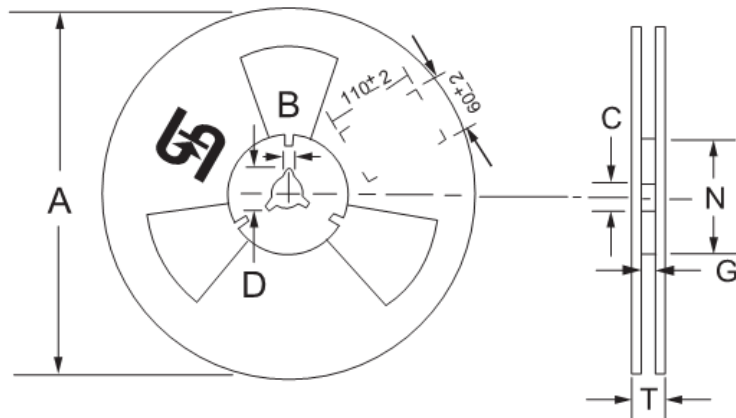
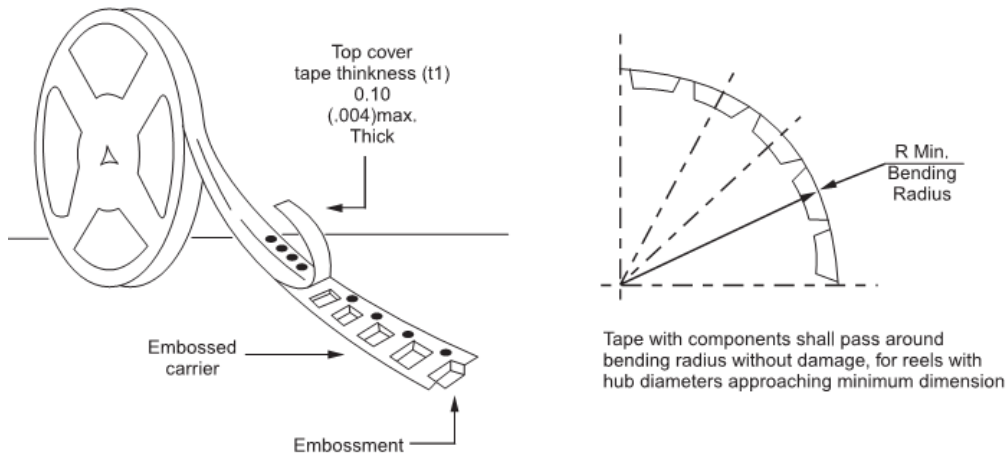

Reel Size	Tape Size	A	B	C	D	N	G	T
				±2.0	±0.4	+0.5;-0.2	min	±1.0
7"	12mm	178	1.9	13	21	62	12.2	14.6
Reel Size	Tape Size	A	B	C	D	N	G	T
				max	±0.5	±0.5	min	±0.5
13"	12mm	330	2	13	20.2	75	12.4	18.4

Unit (mm)

### Suggested PAD Layout

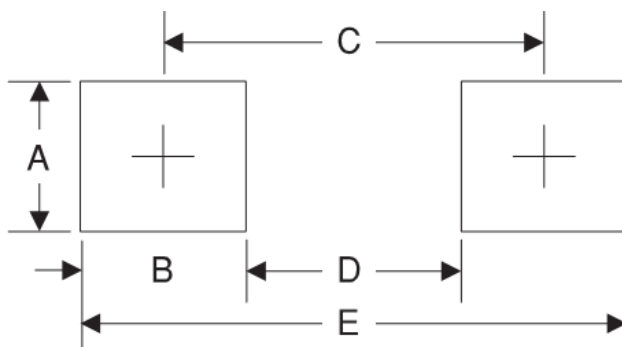

Symbol	Unit(mm)
A	1.78
B	1.51
C	3.92
D	2.41
E	4.43

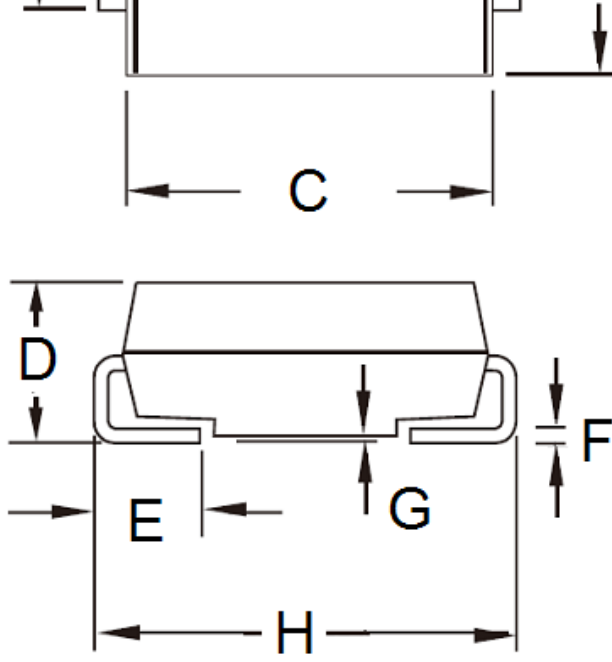

C	4.06	4.60	0.160	0.18
D	1.99	2.50	0.078	0.09
E	0.90	1.41	0.035	0.05
F	0.15	0.31	0.006	0.01
G	0.10	0.20	0.004	0.00
H	4.95	5.33	0.195	0.21

**Marking Diagram**

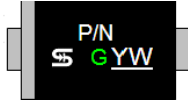

- P/N = Specific Device Code
- G = Green Compound
- YW = Date Code