

- High surge current capability
- Moisture sensitivity level: level 1, per J-STD-020
- Compliant to RoHS Directive 2011/65/EU and in accordance to WEEE 2002/96/EC
- Halogen-free according to IEC 61249-2-21 definition

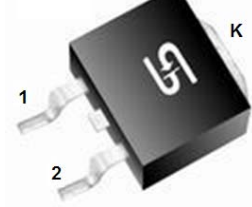

TO-263AB (D²PAK)

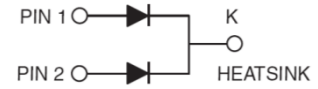

MECHANICAL DATA

Case: TO-263AB (D²PAK)

Molding compound, UL flammability classification rating 94V-0

Base P/N with suffix "G" on packing code - halogen-free

Base P/N with prefix "H" on packing code - AEC-Q101 qualified

Terminal: Matte tin plated leads, solderable per JESD22-B102

Meet JESD 201 class 1A whisker test

with prefix "H" on packing code meet JESD 201 class 2 whisker test

Polarity: As marked

Weight: 1.53 g (approximately)

MAXIMUM RATINGS AND ELECTRICAL CHARACTERISTICS (T_A=25°C unless otherwise noted)

PARAMETER	SYMBOL	MBRS4060CT
Maximum repetitive peak reverse voltage	V _{RRM}	60
Maximum RMS voltage	V _{RMS}	42
Maximum DC blocking voltage	V _{DC}	60
Maximum average forward rectified current	I _{F(AV)}	40
Peak forward surge current, 8.3 ms single half sine-wave superimposed on rated load	I _{FSM}	300
Maximum instantaneous forward voltage (Note 1) I _F =20A @ 25°C I _F =20A @ 125°C I _F =40A @ 25°C I _F =40A @ 125°C	V _F	0.8 0.7 1.0 0.9
Maximum reverse current @ rated VR T _J =25 °C T _J =125 °C	I _R	0.1 20
Voltage rate of change (Rated V _R)	dV/dt	10000
Typical thermal resistance	R _{θJC}	1.5
Operating junction temperature range - In forward mode only	T _J	- 55 to +175
Storage temperature range	T _{STG}	- 55 to +175

Note 1: Pulse test with PW=300µs, 1% duty cycle

EXAMPLE

PREFERRED P/N	PART NO.	AEC-Q101 QUALIFIED	PACKING CODE	GREEN COMPOUND CODE	DF
MBRS4060CT RN	MBRS4060CT		RN		
MBRS4060CT RNG	MBRS4060CT		RN	G	GR
MBRS4060CTHRN	MBRS4060CT	H	RN		AEC

RATINGS AND CHARACTERISTICS CURVES

(TA=25°C unless otherwise noted)

FIG. 1 FORWARD CURRENT DERATING CURVE

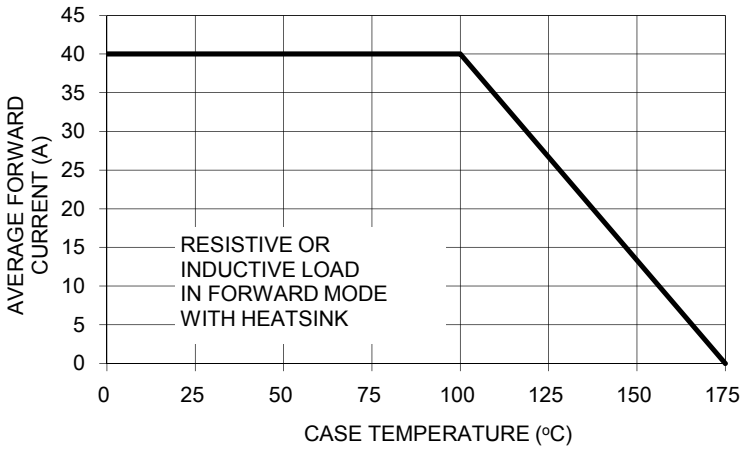

FIG. 2 MAXIMUM NON-REPETITIVE PEAK SURGE CURRENT PER LEG

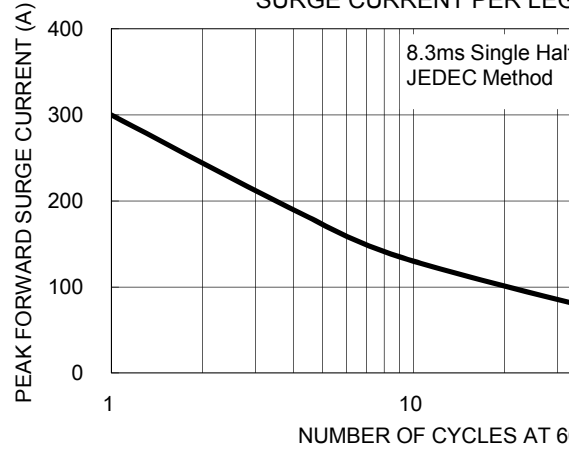

FIG. 3 TYPICAL FORWARD CHARACTERISTICS PER LEG

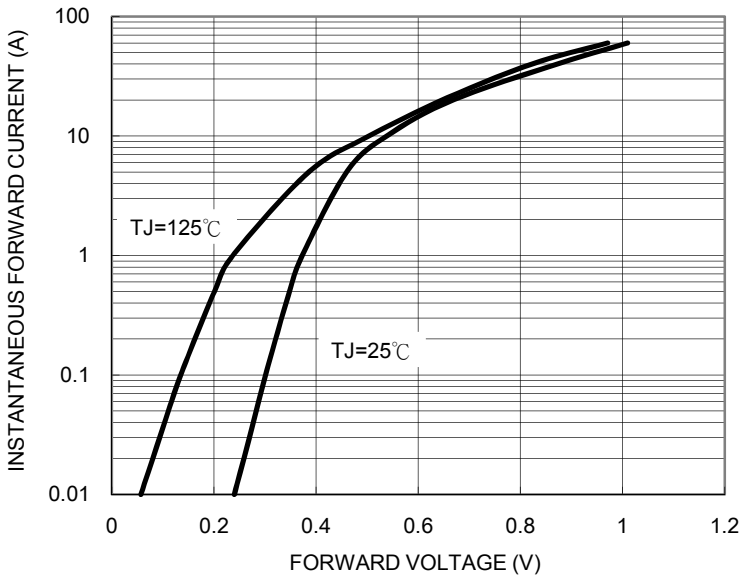
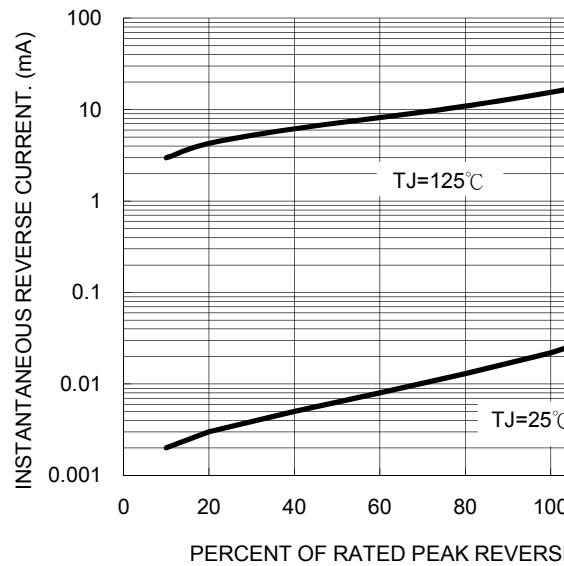
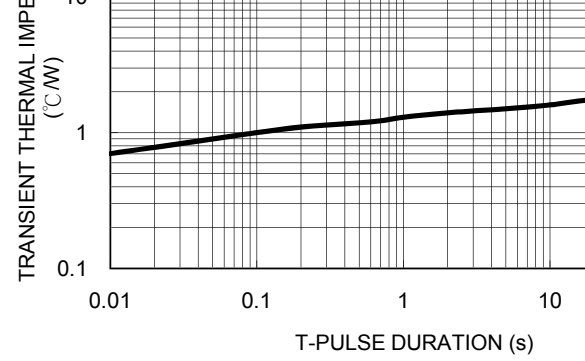
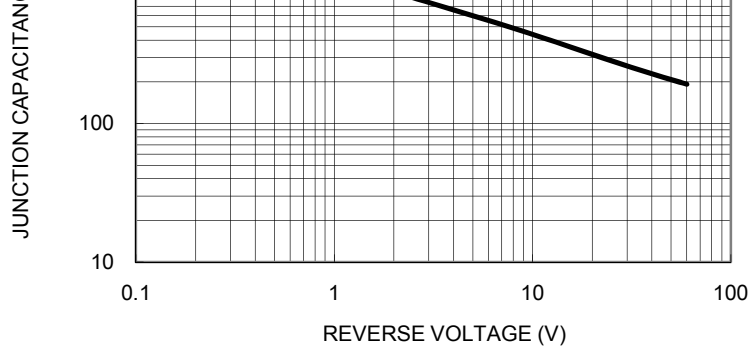
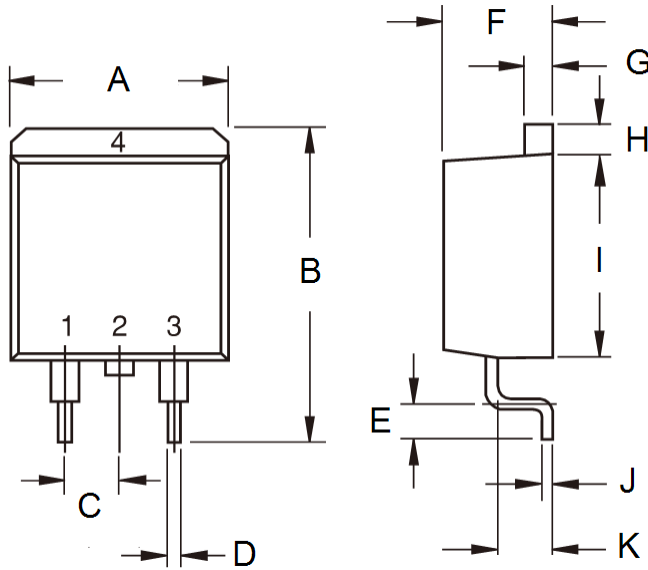

FIG. 4 TYPICAL REVERSE CHARACTERISTICS PER LEG





PACKAGE OUTLINE DIMENSIONS



DIM.	Unit (mm)		Unit (inch)	
	Min	Max	Min	Max
A	-	10.5	-	0.413
B	14.60	15.88	0.575	0.625
C	2.41	2.67	0.095	0.105
D	0.68	0.94	0.027	0.037
E	2.29	2.79	0.090	0.110
F	4.44	4.70	0.175	0.185
G	1.14	1.40	0.045	0.055
H	1.14	1.40	0.045	0.055
I	8.25	9.25	0.325	0.365
J	0.36	0.53	0.014	0.021
K	2.03	2.79	0.080	0.110

SUGGESTED PAD LAYOUT

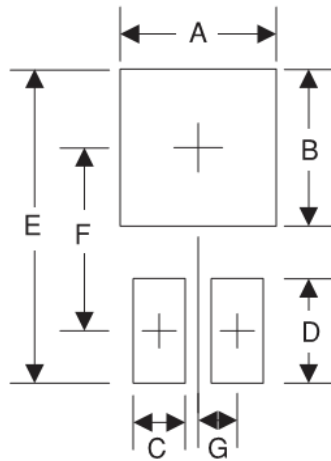

Symbol	Unit (mm)	Unit (inch)
A	10.8	0.425
B	8.3	0.327
C	1.1	0.043
D	3.5	0.138
E	16.9	0.665
F	9.5	0.374
G	2.5	0.098

MARKING DIAGRAM



- P/N = Specific Device Code
- G = Green Compound
- YWW = Date Code
- F = Factory Code

Notice

Specifications of the products displayed herein are subject to change without notice. TSC or anyone on its behalf assumes no responsibility or liability for any errors or inaccuracies.

Information contained herein is intended to provide a product description only. No license, express or implied, of any intellectual property rights is granted by this document. Except as provided in TSC's terms and conditions of sale for such products, TSC assumes no liability whatsoever, and disclaims any express or implied warranty relating to sale and/or use of TSC products including liability or warranties relating to fitness for a particular purpose, merchantability, or infringement of any patent, copyright, or other intellectual property right.

The products shown herein are not designed for use in medical, life-saving, or life-sustaining applications. Customers using or selling these products for use in such applications do so at their own risk and agree to indemnify TSC for any damages resulting from such improper use or sale.

Document Number: D1308005

Ve