

250mW, High Speed Switching Array

FEATURES

- Fast switching speed
- High reverse breakdown voltage rating
- Moisture sensitivity level: level 1, per J-STD-020
- RoHS Compliant

APPLICATIONS

- For general purpose switching application

KEY PARAMETERS		
PARAMETER	VALUE	UNIT
P_D	250	mW
V_{RRM}	85	V
I_F	200	mA
V_F at $I_F=150mA$	1.25	V
$T_{J\ MAX}$	150	°C
Package	SOT-363	
Configuration	Array	

MECHANICAL DATA

- Case: SOT-363
- Molding compound meets UL 94 V-0 flammability rating
- Terminal: Matte tin plated leads, solderable per J-STD-002
- Meet JESD 201 class 1A whisker test
- Weight: 8 mg (approximately)

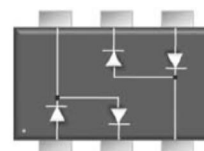
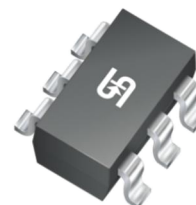

ABSOLUTE MAXIMUM RATINGS ($T_A = 25^\circ C$ unless otherwise noted)				
PARAMETER		SYMBOL	VALUE	UNIT
Marking code on the device			K1	
Power dissipation		P_D	250	mW
Repetitive peak reverse voltage		V_{RRM}	85	V
Repetitive peak forward current		I_{FRM}	450	mA
Mean Forward current		I_F	200	mA
Non-Repetitive peak forward surge current	$t = 1\ \mu s$	I_{FSM}	4.5	A
	$t = 1\ s$		0.5	
Junction temperature range		T_J	-55 to +150	°C
Storage temperature range		T_{STG}	-55 to +150	°C

ELECTRICAL SPECIFICATIONS ($T_A = 25^\circ\text{C}$ unless otherwise noted)					
PARAMETER	CONDITIONS	SYMBOL	MIN	MAX	UNIT
Forward voltage per diode ⁽¹⁾	$I_F = 1\text{mA}$	V_F	-	0.715	V
	$I_F = 10\text{mA}$			0.855	
	$I_F = 50\text{mA}$			1.000	
	$I_F = 100\text{mA}$			1.200	
	$I_F = 150\text{mA}$			1.250	
Reverse voltage	$I_R = 2.5 \mu\text{A}$	V_R	75	-	V
Reverse current @ rated V_R per diode	$V_R = 75 \text{V}$	I_R	-	1	μA
Junction capacitance	1 MHz, $V_R=0\text{V}$	C_J	-	1.5	pF
Reverse recovery time	$I_F=I_R= 10\text{mA}$, $R_L= 100\Omega$	t_{rr}	-	4	ns

Notes:

1. Pulse test with PW=0.3 ms

ORDERING INFORMATION		
ORDERING CODE	PACKAGE	PACKING
BAV99S RFG	SOT-363	3K / 7" Reel
BAV99S RF	SOT-363	3K / 7" Reel

Note: "G" means green compound (halogen free)

CHARACTERISTICS CURVES

($T_A = 25^\circ\text{C}$ unless otherwise noted)

Fig. 1 Maximum Permissible Continuous Forward Current As A Function of Soldering Point Temperature

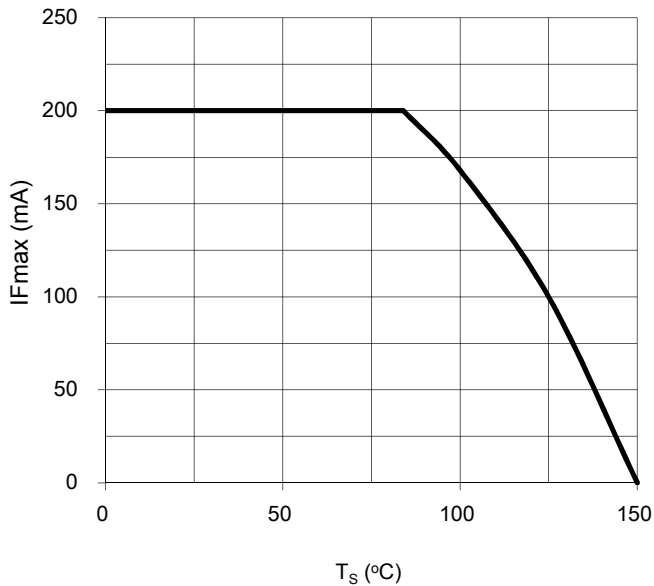

Fig. 2 Forward Current As A Function of Forward Voltage

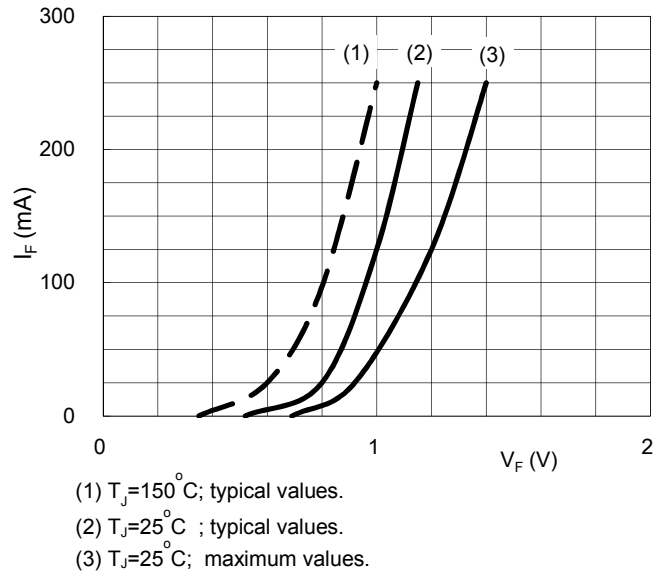
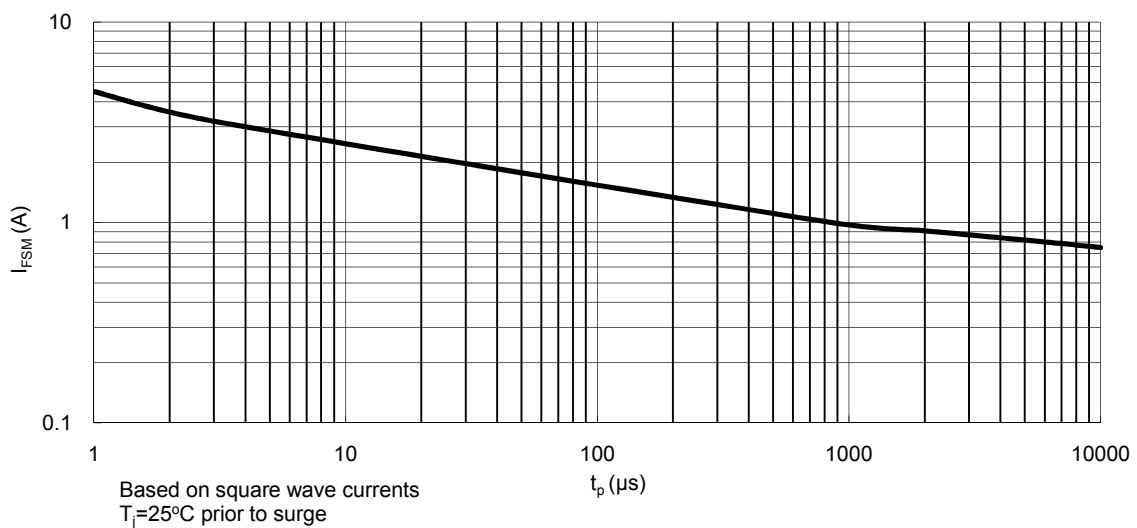
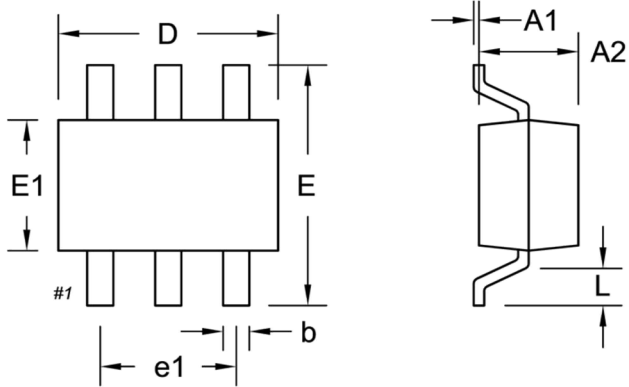

Fig. 3 Maximum Permissible Non-Repetitive Peak Forward Current As A Function of Pulse Duration



PACKAGE OUTLINE DIMENSION

SOT-363



DIM.	Unit (mm)		Unit (inch)	
	Min.	Max.	Min.	Max.
A1	0.00	0.10	0.000	0.004
A2	0.85	1.05	0.033	0.041
b	0.15	0.35	0.006	0.014
D	2.00	2.20	0.079	0.087
E	2.15	2.45	0.085	0.096
E1	1.15	1.35	0.045	0.053
e1	1.20	1.40	0.047	0.055
L	0.25	0.46	0.010	0.018

SUGGEST PAD LAYOUT

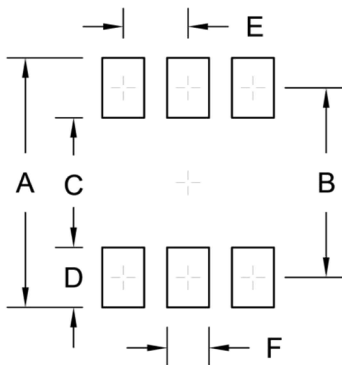

Symbol	Unit (mm)	Unit (inch)
A	2.50	0.098
B	1.90	0.075
C	1.30	0.051
D	0.60	0.024
E	0.65	0.026
F	0.42	0.017

Notice

Specifications of the products displayed herein are subject to change without notice. TSC or anyone on its behalf, assumes no responsibility or liability for any errors or inaccuracies.

Purchasers are solely responsible for the choice, selection, and use of TSC products and TSC assumes no liability for application assistance or the design of Purchasers' products.

Information contained herein is intended to provide a product description only. No license, express or implied, to any intellectual property rights is granted by this document. Except as provided in TSC's terms and conditions of sale for such products, TSC assumes no liability whatsoever, and disclaims any express or implied warranty, relating to sale and/or use of TSC products including liability or warranties relating to fitness for a particular purpose, merchantability, or infringement of any patent, copyright, or other intellectual property right.

The products shown herein are not designed for use in medical, life-saving, or life-sustaining applications. Customers using or selling these products for use in such applications do so at their own risk and agree to fully indemnify TSC for any damages resulting from such improper use or sale.