

**Small Signal Diode**



**Features**

- ✧Fast switching speed
- ✧Surface device type mounting
- ✧Moisture sensitivity level 1
- ✧Matte Tin(Sn) lead finish with Nickel(Ni) underplate
- ✧Pb free version and RoHS compliant
- ✧Green compound (Halogen free) with suffix "G" on packing code and prefix "G" on date code

**Mechanical Data**

- ✧Case :SOT-23 small outline plastic package
- ✧Terminal: Matte tin plated, lead free., solderable per MIL-STD-202, Method 208 guaranteed
- ✧High temperature soldering guaranteed: 260°C/10s
- ✧Weight : 0.008gram (approximately)
- ✧Marking Code : KL3

**Pin Configuration**

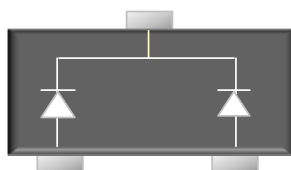

**BAT54C-01**

**Ordering Information**

Package	Part No.	Packing	Marking
SOT-23	BAT54C-01 RF	3K / 7" Reel	KL3
SOT-23	BAT54C-01 RFG	3K / 7" Reel	KL3

**Maximum Ratings and Electrical Characteristics**

Rating at 25°C ambient temperature unless otherwise specified.

**Maximum Ratings**

Type Number	Symbol	Value	Units
Repetitive Peak reverse voltage	$V_{RRM}$	30	V
Forward Continuous Current	$I_F$	200	mA
Repetitive Peak Forward Current ( $t_p \leq 1s; \delta \leq 0.5$ )	$I_{FRM}$	300	mA
Forward surge current @ $t < 1.0s$	$I_{FSM}$	600	mA
Power Dissipation	$P_d$	230	mW
Thermal resistance, junction to ambient air	$R_{\theta JA}$	430	°C/W
Operating and Storage temperature	$T_J, T_{STG}$	-65 to 150	°C

**SOT-23**

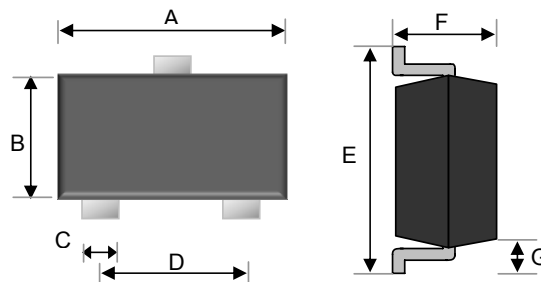

Dimensions	Unit (mm)		Unit (inch)	
	Min	Max	Min	Max
A	2.80	3.00	0.110	0.118
B	1.20	1.40	0.047	0.055
C	0.30	0.50	0.012	0.020
D	1.80	2.00	0.071	0.079
E	2.25	2.55	0.089	0.100
F	0.90	1.20	0.035	0.043
G	0.550 REF		0.022 REF	

**Suggested PAD Layout**

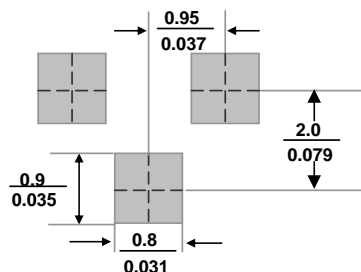

**Small Signal Diode**

**Electrical Characteristics**

Type Number		Symbol	Min	Max	Units
Reverse Breakdown Voltage	$I_R = 100\mu A$	$V_{(BR)}$	30	--	V
Forward Voltage	$I_F = 0.1mA$	$V_F$	--	0.24	V
	$I_F = 1mA$		--	0.32	V
	$I_F = 10mA$		--	0.40	V
	$I_F = 30mA$		--	0.50	V
	$I_F = 100mA$		--	0.80	V
Reverse current	$V_R = 25V$	$I_R$	--	2.0	$\mu A$
Total Capacitance	$V_R = 1V, f = 1.0MHz$	$C_T$	--	10	pF
Reverse Recovery Time	$I_F = I_R = 10mA, R_L = 100\Omega, I_{RR} = 1mA$	$t_{rr}$	--	5.0	nS

**Tape & Reel specification**

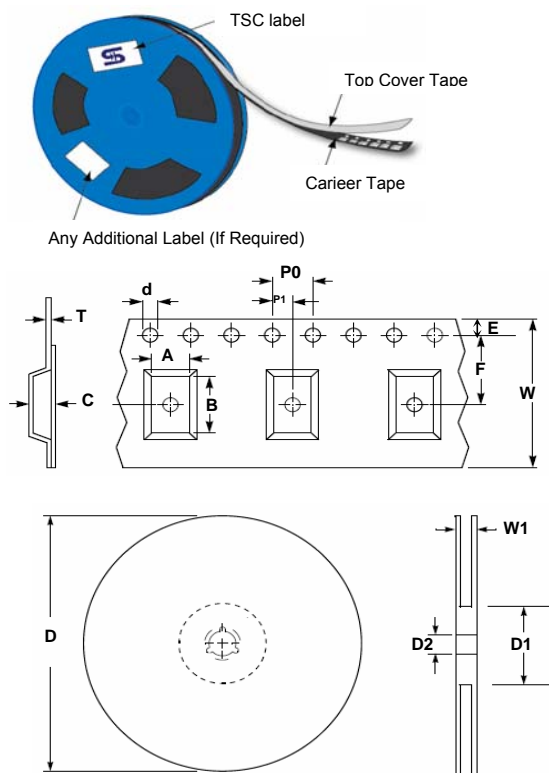

Item	Symbol	Dimension(mm)
Carrier width	A	3.15 ± 0.10
Carrier length	B	2.77 ± 0.10
Carrier depth	C	1.22 ± 0.10
Sprocket hole	d	1.50 ± 0.10
Reel outside diameter	D	178 ± 1
Reel inner diameter	D1	55 Min
Feed hole width	D2	13.0 ± 0.20
Sprocket hole position	E	1.75 ± 0.10
Punch hole position	F	3.50 ± 0.05
Sprocket hole pitch	P0	4.00 ± 0.10
Embossment center	P1	2.00 ± 0.05
Overall tape thickness	T	0.229 ± 0.013
Tape width	W	8.10 ± 0.20
Reel width	W1	12.30 ± 0.20

**Small Signal Diode**

**Rating and Characteristic Curves**

**FIG 1 Typical Forward Characteristics**

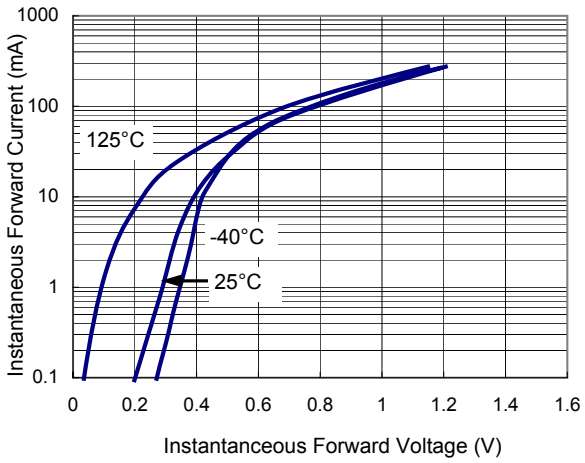

**FIG 2 Typical Reverse Characteristics**

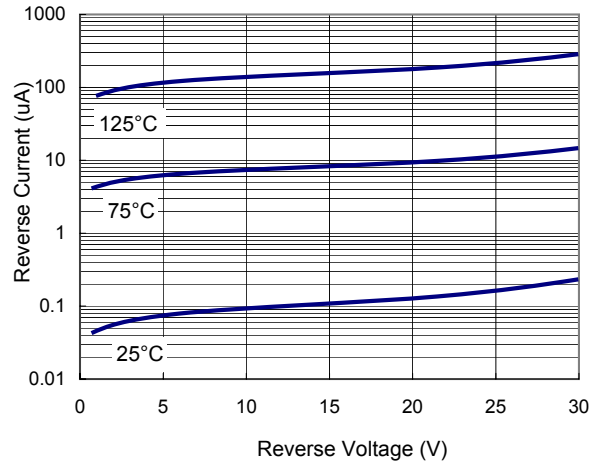

**FIG 3 Admissible Power Dissipation Curve**

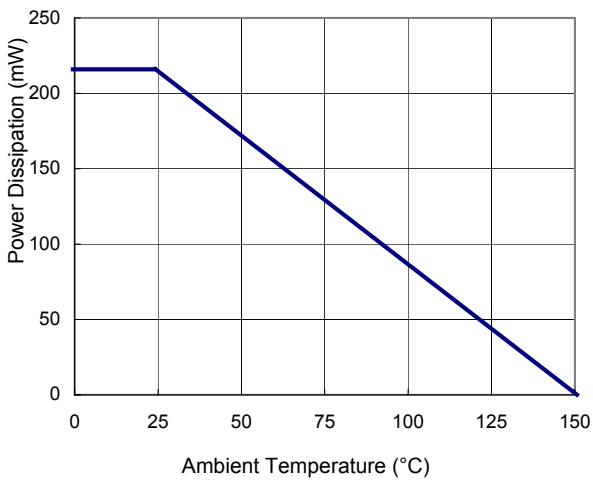

**FIG 4 Typical Junction Capacitance**

