

## SERIES I

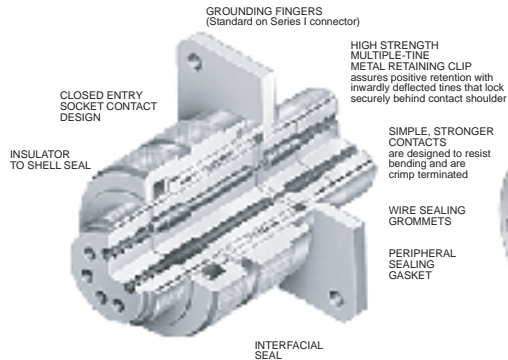

## SERIES II

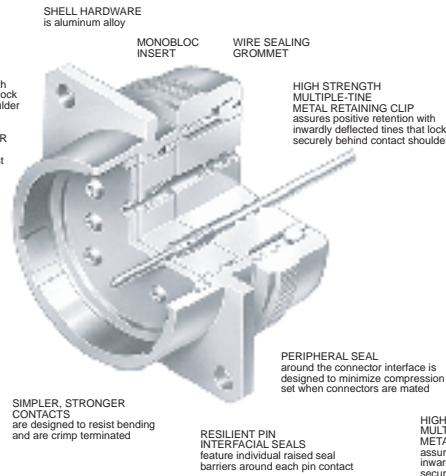

## SERIES III

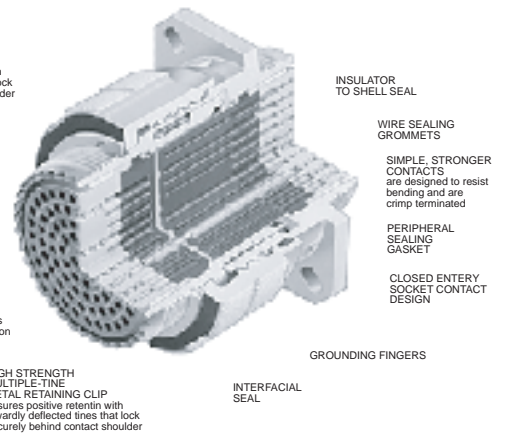

- Corrosion-resistant shells of aluminum alloy with cadmium over nickel plating withstand a 500 hour salt spray exposure
- Rear release crimp snap-in contacts
- High contact density
- Standard MIL-C-39029 contacts, MIL-I-81969 application tools and MIL-STD 1560 insert arrangements
- Special/custom capabilities
- 100% scoop-proof - Series I and III
- Light weight /Low Profile - Series II
- Operates under severe high temperature vibration testing through 200 C - engineered for high density circuitry - Series III
- Interfacial seal helps prevent electrolytic erosion of contacts - Series III
- Superior EMI shielding provides outstanding protection up to 65dB at 10 GHZ. - Series III

## Specification Comparison

Design Criteria	Series I	Series II	Series III
Low Profile/Light Weight	no	yes	no
Scoop Proof	yes	no	yes
Coupling System	Bayonet	Bayonet	Triple Lead Thread
Electrolytic Erosion	no	no	yes
Durability (Cycles)	500	250	500
High Impact Shock	yes	no	yes
External Bending Moment			
Shell Size 25	650 in/lbs	150 in/lbs	1000 in/lbs
Random Vibration "J"	Ambient	Ambient	492 F
Sine Vibration	30G, Ambient		60G, -85 to +392 F
Sand, Dust, Ice	yes		yes
Shell Size	9-25	8-24	9-25

## Contact Rating

Contact Size	Test Current DC Test Amperage	Maximum Millivolt Drop*	Crimp Well Data	
			Well Diameter	Well Depth
22D	5	40	.0345 ± .0010	.157/.141
22M*	3	30	.0280 ± .0010	.157/.141
22*	5	40	.0365 ± .0010	.157/.141
20	7.5	35	.0470 ± .0010	.229/.209
16	13	25	.0670 ± .0010	.229/.209
12	23	25	.1000 ± .0020	.229/.209

- \* Maximum millivolt drop data is determined by measuring resistance of mated contacts from end to end.
- Inactive for new design, available from the factory.

**Performance and Material Specifications**

**MATERIALS AND FINISHES**

	Receptacle	Grounded Plug
Shell	Aluminum alloy	Aluminum alloy*
Insulator	High grade plastic	High grade plastic
Contacts	Copper alloy, gold plate	Copper alloy, gold plate
Grommet and Seal	Silicone base elastomer	Silicone base elastomer
Jam Nut	Aluminum alloy	-
Grounding Spring	-	Beryllium copper

\*Finish as noted in How To Order sections.

**ELECTRICAL DATA**

Contact Size: 22D, 22M\*, 22\*, 20, 16 and 12

**Contact Rating and Wire Size Accomodation**

Wire Size	Contact Size and Test Amps					
	22D	22M*	22*	20	16	12
28	1.5	1.5	-	-	-	-
26	2.0	2.0	2.0	-	-	-
24	3.0	3.0	3.0	3.0	-	-
22	5.0	-	5.0	5.0	-	-
20	-	-	-	7.5	7.5	-
18	-	-	-	-	10.0	-
16	-	-	-	-	13.0	-
14	-	-	-	-	-	17.0
12	-	-	-	-	-	23.0

**Service Rating (Unmated Condition)**

Test Voltages	Service Rating M	Service Rating I	Service Rating II
Sea Level	1300	1800	2300
100,000 ft.	200	200	200

**Contact Termination; Crimp contact per MIL-C-39029**

\*Inactive for new design

**Test Data**

Test Description	Parameters
<b>Durability</b>	500 cycles of mating and unmating, 250 cycles for Series II with spring fingers
<b>Temperature Range</b>	Class F, C; - 65°C (-85°F) to + 200°C (+392°F) Class W: - 65°C (-85°F) to + 175°C (+347°F)
<b>Vibration</b>	Mated connectors are vibrated with weights to simulate rear accessory loads to the following levels: Sine Vibration: Up to 60 G's - Series I & III (at rated temperature - Series III) Not applicable for Series II. Random Vibration: 43.7 Grms at rated temperature - Series III 49.5 Grms at Ambient Temperature - Series I & III 43.7 Grms at Ambient Temperature - Series II
<b>EMI Shielding Effectiveness</b>	Class F: EMI leakage attenuation, greater than 90dB at 100Mhz, greater than 65dB at 10 GHz. Shell to shell conductivity, 1.0 millivolt max. resistance. Class W: EMI leakage attenuation, greater than 90dB at 100 MHz, greater than 50dB at 10 GHz. Shell to shell conductivity, 2.5 millivolt max.
<b>Corrosion Resistant</b>	Class C, W, Y, will withstand 500 hours salt spray. Class F, N, will withstand 48 hours salt spray.
<b>Fluid Immersion</b>	Connectors are fluid resistant to many fuels, solvents, coolants and oils.
<b>High Impact Shock</b>	Mated conectors terminated with MIL-C-915 cable and environmentally sealed backshells will withstand high impact shock per MIL-S-901. Applicable to Series I & III only.
<b>Altitude</b>	Designed to operate between sea level and 100,000 ft. above sea level.
<b>Other Environments</b>	Mated connectors shall withstand sand and dust per method 110 of MIL-STD-202 and be ice resistant. Applicable to Series I & III only.

NOTE: For hermetic standard or test data please consult ITT Cannon Canada.

Insert Availability and Identification

Series II	Series I & III	Service Rating	Total Con-tacts	Contact Size							
				22D	22M*	22*	20	16	12	8	
8-6 •	9-6 •	M	6		6						
8-35	9-35	M	6	6							
8-98	9-98	I	3				3				
	11-4	I	4				4				
10-5	11-5	I	5				5				
10-13 •	11-13 •	M	13		13						
10-35	11-35	M	13	13							
10-98	11-98	I	6				6				
10-99	11-99	I	7				7				
12-3		II	3						3		
12-4	13-4	I	4						4		
12-8	13-8	I	8				8				
12-22 •	13-22 •	M	22		22						
12-35	13-35	M	22	22							
12-98	13-98	I	10				10				
14-5	15-5	II	5						5		
14-15	15-15	I	15				14		1		
14-18	15-18	I	18				18				
	15-19	I	19				19				
14-35	15-35	M	37	37							
14-37 •	15-37 •	M	37		37						
14-97	15-97	I	12				8		4		
16-6	17-6	I	6							6	
16-8	17-8	II	8						8		
16-26	17-26	I	26				26				
16-35	17-35	M	55	55							
16-42 •		M	42			42					
16-55 •	17-55 •	M	55		55						
16-99	17-99	I	23				21		2		
18-11	19-11	II	11						11		
18-28	19-28	I	28				26		2		
18-30	19-30	I	30				29		1		
18-32	19-32	I	32				32				
18-35	19-35	M	66	66							
18-53 •		M	53			53					
18-66 •	19-66 •	M	66		66						
20-1 •	21-1 •	M	79		79						
20-2 •		M	65			65					
	21-11	I	11							11	
20-16	21-16	II	16					16			
20-35	21-35	M	79	79							
20-39	21-39	I	39				37		2		
20-41	21-41	I	41				41				
	21-75	M	4								4**†
22-1 •	23-1 •	M	100		100						
22-2 •	23-2 •	M	85			85					
22-21	23-21	II	21					21			
22-32	23-32	I	32				32				
22-35	23-35	M	100	100							
22-53	23-53	I	53				53				
22-55	23-55	I	55				55				
24-1 •	25-1 •	M	128		128						
24-2 •	25-2 •	M	100			100					
24-4	25-4	I	56				48		8		
	25-19	I	19							19	
24-24	25-24	I	24					12		12	
24-29	25-29	I	29					29			
24-35	25-35	M	128	128							
	25-37	I	37						37		
	25-43	I	43				23		20		
	25-46	I, Coax	46				40		4		2*†
	25-8	Coax	8								8****
	25-20	N	30				10		13		4* 3**
	25-42	I, Coax	42				38				4*
24-61	25-61	I	61				61				
	25-64	I	64	40			8		10		6
	25-66	I	66	53			2		11		

\* Coax

\*\* Twinax

\*\*\* Coax/Twinax

† For RG180/U and RG195/U cables only (check factory for other cable applications)

• Inactive for new design.

## How To Order

### Military Nomenclature

#### MS NUMBER SHELL STYLE

- MS27466 - Wall Mounting Receptacle
- MS27468 - Jam Nut Receptacle
- MS27467 - Grounded Plug
- MS27656 - Wall Mounting Receptacle (back panel mounting)
- MS27505 - Box Mounting Receptacle (back panel) (Class E)

#### CLASS

- E - Inactive for new design. Superseded by Class T.
- P - Environment - resistant with straight potting cup accessories
- T - Environment - resistant with accessory threads and teeth, except MS27505 (without rear accessory) (Class T not applicable to MS27505)

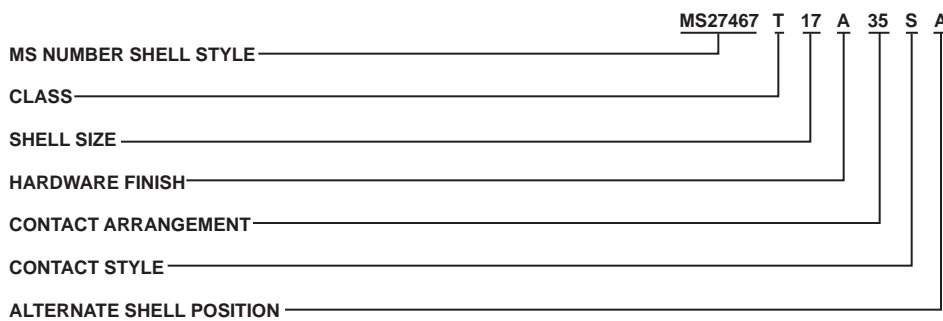

**SHELL SIZE**  
9, 11, 13, 15, 17, 19, 21, 23, and 25

**HARDWARE FINISH STANDARD**  
 A - Bright cadmium over electroless nickel plate, -85°F to +302°F (-65°C to +150°C)  
 B - Olive drab cadmium over electroless nickel plate, -85°F to +347°F (-65°C to +175°C)  
 F - Electroless nickel, -85°F to +392°F (-65°C to +200°C)

**CONTACT ARRANGEMENT**  
See pages 132 and 133.

#### CONTACT STYLE

- P - Pin
  - S - Socket
  - \*A - Less Pin Contact
  - \*B - Less Socket Contact
- See pages 296-298 for fiber Optic contacts.

\*Used only when other than power contacts are to be installed (i.e. shielded, thermocouple, etc.)

#### ALTERNATE SHELL POSITION

A, B, C, and D. (Not required for normal). See page 131.

Note: To order MS connectors less standard power contacts, purchase order must state "Less Contacts"

### ITT Cannon Nomenclature

#### SERIES PERFIX

- KJL - Series I-Scoop proof

#### SHELL STYLE

- 0 - Wall mounting receptacle
- 3 - Wall mounting receptacle (back panel mounting)
- 5 - Box mounting receptacle (back panel mounting)
- 6 - Straight plug, grounded
- 7 - Jam nut receptacle

#### CLASS

- E - Inactive for new design. Superseded by Class T.
- F - Environment - resistant with strain relief accessory
- P - Environment - resistant with straight potting cup accessory
- T - Environment - resistant (without rear accessory) (Class T not applicable to KJL5)



NOTE: KJL supplied with exact complement of contacts.

**SHELL SIZE**  
9, 11, 13, 15, 17, 19, 21, 23 and 25

**HARDWARE FINISH STANDARD**  
 A - Bright cadmium over electroless nickel plate, -85°F to +302°F (-65°C to +150°C)  
 B - Olive drab cadmium over electroless nickel plate, -85°F to +347°F (-65°C to +175°C)  
 N - Electroless nickel, -85°F to +392°F (-65°C to +200°C)

#### CONTACT ARRANGEMENT

See pages 132 and 133.

#### CONTACT STYLE

- P - Pin
  - S - Socket
- See pages 296-298 for Fiber Optic Contacts.

#### ALTERNATE SHELL POSITION

N (normal), A, B, C, D. See page 131.

#### LESS CONTACTS

Use "L" when connectors are ordered less contacts, sealing plugs and insertion/extraction tool ("L" is not stamped on connectors).

## Wall Mounting Receptacle

MS27466  
(MS service class E, P, T)

KJL0

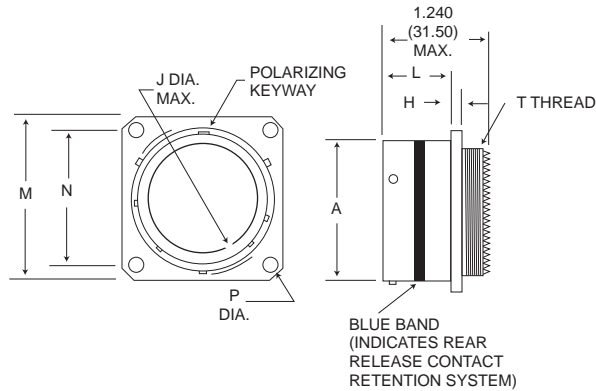

NOTE: For backshell dimensions and configurations, see pages 135 and 136.

Shell Size	A Dia. Max.	H Max.	J Dia. Max.	L Max.	M Max.	N T.P.	P Dia. Max.	T Thread	Overall Length With Backshells	
									F Cable Clamp	P Potting Max.
9	.573 (14.55)	.100 (2.54)	.662 (16.81)	.632 (16.05)	.958 (24.33)	.719 (18.26)	.138 (3.51)	7/16-28UNEF-2A	1.846 (46.89)	1.451 (36.86)
11	.701 (17.81)	.100 (2.54)	.810 (20.57)	.632 (16.05)	1.051 (26.70)	.812 (20.62)	.138 (3.51)	9/16-24UNEF-2A	1.846 (46.89)	1.451 (36.86)
13	.851 (21.62)	.100 (2.54)	.960 (24.38)	.632 (16.05)	1.145 (29.08)	.906 (23.01)	.138 (3.51)	11/16-24UNEF-2A	1.846 (46.89)	1.451 (36.86)
15	.976 (24.79)	.100 (2.54)	1.085 (27.56)	.632 (16.05)	1.239 (31.47)	.969 (24.61)	.138 (3.51)	13/16-20UNEF-2A	1.846 (46.89)	1.451 (36.86)
17	1.101 (27.97)	.100 (2.54)	1.210 (30.73)	.632 (16.05)	1.332 (33.83)	1.062 (26.97)	.138 (3.51)	15/16-20UNEF-2A	1.966 (49.94)	1.451 (36.86)
19	1.208 (30.68)	.100 (2.54)	1.317 (33.45)	.632 (16.05)	1.458 (37.03)	1.156 (29.36)	.138 (3.51)	1-1/16-18UNEF-2A	1.966 (50.70)	1.451 (36.86)
21	1.333 (33.86)	.130 (3.30)	1.442 (36.63)	.602 (15.29)	1.582 (40.18)	1.250 (31.75)	.138 (3.51)	1-3/16-18UNEF-2A	1.966 (50.70)	1.451 (36.86)
23	1.458 (37.03)	.130 (3.30)	1.567 (39.80)	.602 (15.29)	1.708 (43.38)	1.375 (34.93)	.157 (3.99)	1-5/16-18UNEF-2A	1.966 (50.70)	1.451 (36.86)
25	1.583 (40.21)	.130 (3.30)	1.692 (42.98)	.602 (15.29)	1.832 (46.53)	1.500 (38.10)	.157 (3.99)	1-7/16-18UNEF-2A	1.966 (50.70)	1.451 (36.86)

## Wall Mounting Receptacle (Back Panel)

MS27656  
(MS service class E, P, T)

KJL3

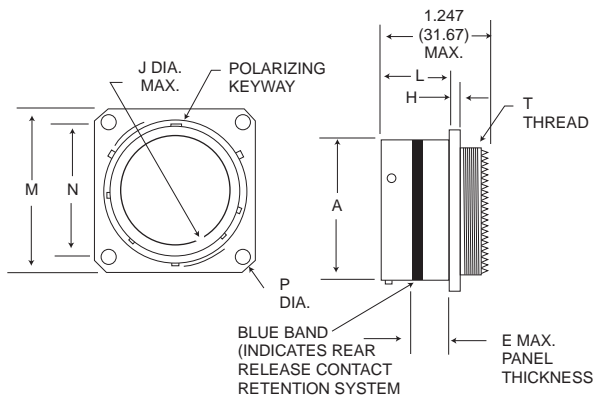

NOTE: For backshell dimensions and configurations, see pages 135 and 136.

Shell Size	A Dia. Max.	E Max.	H Dia. Max.	J Dia. Max.	L Max.	M Max.	N T.P.	P Dia. Max.	T Thread	Overall Length With Backshells	
										F Cable Clamp	P Potting Max.
9	.573 (14.55)	.234 (5.94)	.100 (2.54)	.662 (16.81)	.820 (20.83)	.958 (24.33)	.719 (18.26)	.138 (3.51)	7/16-28UNEF-2A	1.805 (45.85)	1.410 (35.81)
11	.701 (17.81)	.234 (5.94)	.100 (2.54)	.810 (20.57)	.820 (20.83)	1.051 (26.70)	.812 (20.62)	.138 (3.51)	9/16-24UNEF-2A	1.805 (45.85)	1.410 (35.81)
13	.851 (21.62)	.234 (5.94)	.100 (2.54)	.960 (24.38)	.820 (20.83)	1.145 (29.08)	.906 (23.01)	.138 (3.51)	11/16-24UNEF-2A	1.805 (45.85)	1.410 (35.81)
15	.976 (24.79)	.234 (5.94)	.100 (2.54)	1.085 (27.56)	.820 (20.83)	1.239 (31.47)	.969 (24.61)	.138 (3.51)	13/16-20UNEF-2A	1.805 (45.85)	1.410 (35.81)
17	1.101 (27.97)	.234 (5.94)	.100 (2.54)	1.210 (30.73)	.820 (20.83)	1.332 (33.83)	1.062 (26.97)	.138 (3.51)	15/16-20UNEF-2A	1.935 (48.90)	1.410 (35.81)
19	1.208 (30.68)	.234 (5.94)	.100 (2.54)	1.317 (33.45)	.820 (20.83)	1.458 (37.03)	1.156 (29.36)	.138 (3.51)	1-1/16-18UNEF-2A	1.955 (49.66)	1.410 (35.81)
21	1.333 (33.86)	.204 (5.18)	.130 (3.30)	1.442 (36.63)	.790 (20.07)	1.582 (40.18)	1.250 (31.75)	.138 (3.51)	1-3/16-18UNEF-2A	1.955 (49.66)	1.410 (35.81)
23	1.458 (37.03)	.204 (5.18)	.130 (3.30)	1.567 (39.80)	.790 (20.07)	1.708 (43.38)	1.375 (34.93)	.157 (3.99)	1-5/16-18UNEF-2A	1.955 (49.66)	1.410 (35.81)
25	1.583 (40.21)	.193 (4.90)	.130 (3.30)	1.692 (42.98)	.790 (20.07)	1.832 (46.53)	1.500 (38.10)	.157 (3.99)	1-7/16-18UNEF-2A	1.955 (49.66)	1.410 (35.81)

Performance Specifications-Pages 115-116 Contacts, Sealing Plugs, Assembly Tools - Pages 134, 136-137 Contact Arrangements - Pages 132-133

## Box Mounting Rectacle (Back Panel)

MS27505E  
(MS service class E)

KJL5E

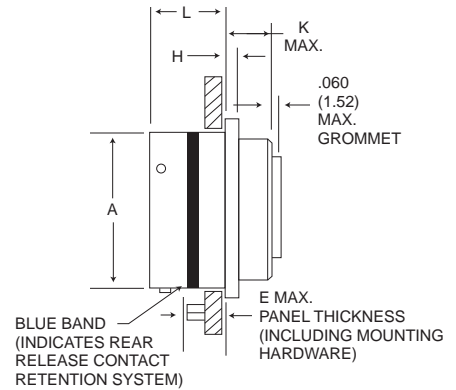
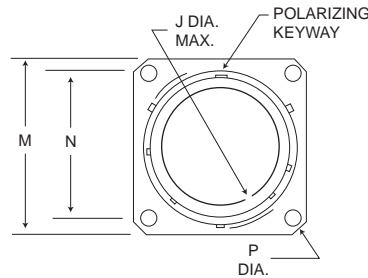

NOTE: This connector does not accommodate backshells.

Shell Size	A Dia. Max.	E Max.	H Max.	J Dia. Max.	K Max.	L Max.	M Max.	N T.P.	P Dia. Max.
9	.573 (14.55)	.234 (5.94)	.100 (2.54)	.662 (16.81)	.219 (5.56)	.820 (20.83)	.958 (24.33)	.719 (18.26)	.138 (3.51)
11	.701 (17.81)	.234 (5.94)	.100 (2.54)	.810 (20.57)	.219 (5.56)	.820 (20.83)	1.051 (26.70)	.812 (20.62)	.138 (3.51)
13	.851 (21.62)	.234 (5.94)	.100 (2.54)	.960 (24.38)	.219 (5.56)	.820 (20.83)	1.145 (29.08)	.906 (23.01)	.138 (3.51)
15	.976 (24.79)	.234 (5.94)	.100 (2.54)	1.085 (27.56)	.219 (5.56)	.820 (20.83)	1.239 (31.47)	.969 (24.61)	.138 (3.51)
17	1.101 (27.97)	.234 (5.94)	.100 (2.54)	1.210 (30.73)	.219 (5.56)	.820 (20.83)	1.332 (33.83)	1.062 (26.97)	.138 (3.51)
19	1.208 (30.68)	.234 (5.94)	.100 (2.54)	1.317 (33.45)	.219 (5.56)	.820 (20.83)	1.458 (37.03)	1.156 (29.36)	.138 (3.51)
21	1.333 (33.86)	.204 (5.18)	.130 (3.30)	1.442 (36.63)	.250 (6.35)	.790 (20.07)	1.582 (40.18)	1.250 (31.75)	.138 (3.51)
23	1.458 (37.03)	.204 (5.18)	.130 (3.30)	1.567 (39.80)	.250 (6.35)	.790 (20.07)	1.708 (43.38)	1.375 (34.93)	.157 (3.99)
25	1.583 (40.21)	.193 (4.90)	.130 (3.30)	1.692 (42.98)	.250 (6.35)	.790 (20.07)	1.832 (46.53)	1.500 (38.10)	.157 (3.99)

## Straight Plug Grounded

MS27467  
(MS service class E, P, T)

KJL6

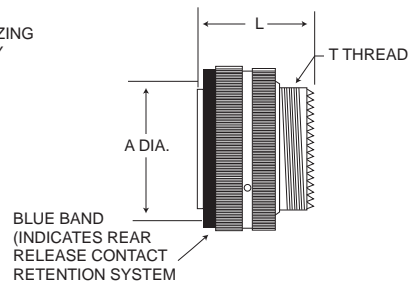
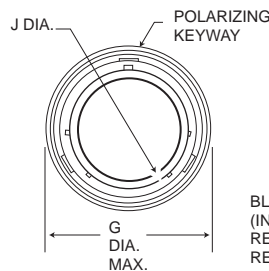

NOTE: For backshell dimensions and configurations, see pages 135 and 136.

Shell Size	A Max.	G Dia. Max.	J Dia. Max.	(Class T)		Overall Length With Backshells	
				L Max.	T Thread	F Cable Clamp	P Potting Max.
9	.585 (14.86)	.859 (21.82)	.483 (12.27)	1.234 (31.34)	7/16-28UNEF-2A	1.793 (45.54)	1.671 (42.44)
11	.717 (18.21)	.984 (24.99)	.611 (15.52)	1.234 (31.34)	9/16-24UNEF-2A	1.793 (45.54)	1.671 (42.44)
13	.866 (22.00)	1.156 (29.36)	.760 (19.30)	1.234 (31.34)	11/16-24UNEF-2A	1.793 (45.54)	1.671 (42.44)
15	.990 (25.15)	1.281 (32.54)	.885 (22.48)	1.234 (31.34)	13/16-20UNEF-2A	1.793 (45.54)	1.671 (42.44)
17	1.115 (28.32)	1.406 (35.71)	1.010 (25.65)	1.234 (31.34)	15/16-20UNEF-2A	1.913 (48.59)	1.671 (42.44)
19	1.222 (31.04)	1.516 (38.51)	1.115 (28.32)	1.234 (31.34)	1-1/16-18UNEF-2A	1.943 (49.35)	1.671 (42.44)
21	1.347 (34.21)	1.641 (41.68)	1.240 (31.50)	1.234 (31.34)	1-3/16-18UNEF-2A	1.943 (49.35)	1.766 (44.86)
23	1.472 (37.39)	1.766 (44.86)	1.365 (34.67)	1.234 (31.34)	1-5/16-18UNEF-2A	1.943 (49.35)	1.766 (44.86)
25	1.597 (40.56)	1.891 (48.03)	1.490 (37.85)	1.234 (31.34)	1-7/16-18UNEF-2A	1.943 (49.35)	1.766 (44.86)

Performance Specifications-Pages 115-116

Contacts, Sealing Plugs, Assembly Tools - Pages 134, 136-137

Contact Arrangements - Pages 132-133

## Jam Nut Receptacle

MS27468

KJL7

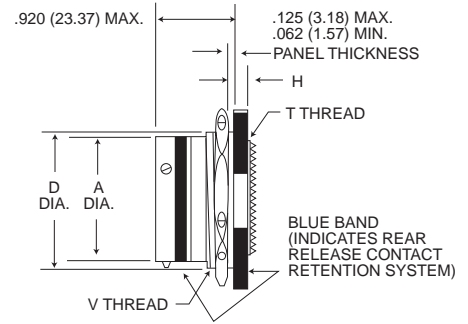
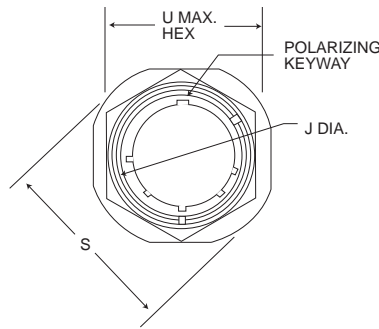

NOTE: For backshell dimensions and configurations, see pages 135 and 136.

Shell Size	A Dia. Max.	D Max.	H Max.	J Dia. Max.	S Dia. Max.	T Thread	U Max. Hex.	V Thread Class 2A	Overall Length With Backshells	
									F Cable Clamp	P Potting Max.
9	.573 (14.55)	.655 (16.64)	.120 (3.05)	.662 (16.81)	1.204 (30.58)	7/16-28UNEF-2A	.892 (22.66)	11/16-24UNEF	1.846 (46.89)	1.451 (36.86)
11	.701 (17.81)	.755 (19.18)	.120 (3.05)	.810 (20.57)	1.391 (35.33)	9/16-24UNEF-2A	1.017 (25.83)	13/16-24UNEF	1.846 (46.89)	1.451 (36.86)
13	.851 (21.62)	.942 (23.93)	.120 (3.05)	.960 (24.38)	1.516 (35.51)	11/16-24UNEF-2A	1.205 (30.61)	1-20UNEF	1.846 (46.89)	1.451 (36.86)
15	.976 (24.79)	1.066 (27.08)	.120 (3.05)	1.085 (27.56)	1.641 (41.68)	13/16-20UNEF-2A	1.329 (33.76)	1-1/8-18UNEF	1.846 (46.89)	1.451 (36.86)
17	1.101 (27.97)	1.191 (30.25)	.120 (3.05)	1.210 (30.73)	1.766 (44.86)	15/16-20UNEF-2A	1.455 (36.96)	1-1/4-18UNEF	1.966 (49.94)	1.451 (36.86)
19	1.208 (30.68)	1.316 (33.43)	.151 (3.84)	1.317 (33.45)	1.954 (49.63)	1-1/16-18UNEF-2A	1.579 (40.11)	1-3/8-18UNEF	1.996 (50.70)	1.451 (36.86)
21	1.333 (33.86)	1.441 (36.60)	.151 (3.84)	1.442 (36.63)	2.078 (52.78)	1-3/16-18UNEF-2A	1.705 (43.31)	1-1/2-18UNEF	1.996 (50.70)	1.451 (36.86)
23	1.458 (37.03)	1.566 (39.78)	.151 (3.84)	1.567 (39.80)	2.204 (55.98)	1-5/16-18UNEF-2A	1.829 (46.46)	1-5/8-18UNEF	1.996 (50.70)	1.451 (36.86)
25	1.583 (40.21)	1.691 (42.95)	.151 (3.84)	1.692 (42.98)	2.328 (59.13)	1-7/16-18UNEF-2A	20.17 (51.23)	1-3/4-18UNS	1.996 (50.70)	1.451 (36.86)

Performance Specifications - Pages 115-116

Contacts, Sealing Plugs, Assembly Tools - Pages 134, 136-137

Contacts Arrangements - Pages 132-133

## Panel Cutouts

### Flange Mounted Receptacles

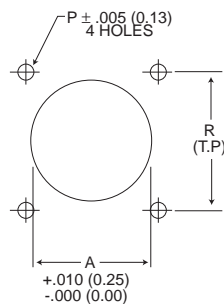

### Jam Nut Receptacles

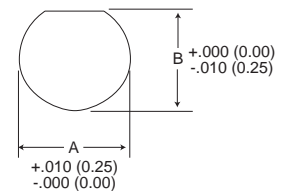

(Class T)

Shell Size	A Dia.	P Dia.	R	Mtg. Screw
9	.665 (16.89)	1.25 (3.18)	.719 (18.26)	#4
11	.812 (20.62)	1.25 (3.18)	.812 (20.62)	#4
13	.965 (24.51)	1.25 (3.18)	.906 (23.01)	#4
15	1.085 (27.55)	1.25 (3.18)	.969 (24.61)	#4
17	1.210 (30.73)	1.25 (3.18)	1.062 (26.7)	#4
19	1.322 (33.57)	1.25 (3.18)	1.156 (29.36)	#4
21	1.447 (36.75)	1.25 (3.18)	1.250 (31.75)	#4
23	1.569 (39.85)	1.25 (3.18)	1.375 (34.93)	#6
25	1.703 (43.25)	1.25 (3.18)	1.500 (38.10)	#6

Shell Size	A Dia.	B Dia.
9	.700 (17.28)	.670 (17.02)
11	.825 (20.96)	.770 (19.59)
13	1.010 (25.65)	.955 (24.26)
15	1.135 (28.83)	1.085 (27.56)
17	1.260 (32.00)	1.210 (30.73)
19	1.385 (35.18)	1.335 (33.91)
21	1.510 (38.35)	1.460 (37.08)
23	1.635 (41.53)	1.585 (40.26)
25	1.760 (44.70)	1.710 (43.43)

## How To Order

### Military Nomenclature

#### MS NUMBER SHELL STYLE

- MS27472 - Wall Mounting Receptacle
- MS27473 - Straight Plug
- MS27474 - Jam Nut Receptacle
- MS27484 - Grounded Plug
- MS27497 - Wall Mounting Receptacle (back panel mounting)
- MS27513 - Box Mounting Receptacle
- MS27479 - Wall Mounting Receptacle (C Finish) - Inactive, use MS27472
- MS27480 - Straight Plug (C Finish) - inactive, use MS27473
- MS27481 - Jam Nut Receptacle (C Finish) - inactive, use MS27474
- MS27499 - Box Mounting Receptacle (Class E)
- MS27508 - Box Mounting (back panel mounting) (Class E)

#### CLASS

- E - Environment - resistant with rear accessory (without strain relief)
- P - Environment - resistant with straight potting cup accessories
- T - Environment - resistant (without rear accessory). (Class T not applicable to MS27499, MS27513, and MS27508.)

MS NUMBER SHELL STYLE \_\_\_\_\_

CLASS \_\_\_\_\_

SHELL SIZE \_\_\_\_\_

HARDWARE FINISH \_\_\_\_\_

CONTACT ARRANGEMENT \_\_\_\_\_

CONTACT STYLE \_\_\_\_\_

ALTERNATE SHELL POSITION \_\_\_\_\_

#### SHELL SIZE

8, 10, 12, 14, 16, 18, 20, 22, 24.

#### HARDWARE FINISH STANDARD

- A - Bright cadmium over electroless nickel plates, - 85°F to + 302°F (- 65°C to + 150°C)
- B - Olive drab cadmium over electroless nickel plate, - 85°F to + 347°F (- 65°C to + 175°C)
- C - Anodic (non-conductive), - 85°F to + 392°F (-65°C to + 200°C).  
Not applicable to MS27484.
- F - Electroless nickel, - 85°F to + 392°F (-65°C to + 200°C)

#### CONTACT ARRANGEMENT

See pages 132 and 133.

#### CONTACT STYLE

- P - Pin
- S - Socket
- \*A - Less Pin Contact
- \*B - Less Socket Contact

\*Used only when other than power contacts are to be installed (i.e. shielded, thermocouple, etc.)

#### ALTERNATE SHELL POSITION

A, B, C, and D (not required for normal). See page 131.

Note: To order MS connectors less standard power contacts, purchase order must state "Less Contacts".

MS27473 T 18 A 35 S A

### ITT Cannon Nomenclature

#### SERIES PREFIX

- KJ - Series II - Low Profile

#### SHELL STYLE

- 0 - Wall mounting receptacle
- 2 - Box mounting receptacle (available as hermetic)
- 3 - Wall mounting receptacle (back panel mounting)
- 5 - Box mounting receptacle (back panel mounting)
- 6 - Straight plug
- G6 - Straight plug, grounded
- 7 - Jam nut receptacle (available as hermetic)

#### CLASS

- E - Environment - resistant with rear accessory (without strain relief)
- F - Environment - resistant with strain relief accessory
- P - Environment - resistant with straight potting cup accessory
- R - Environment - resistant with full grommet seal without rear accessory; shell styles 2 and 5 only
- T - Environment - resistant (without rear accessory). (Class T not applicable to KJ2E, KJ2R, KJ5E and KJ5R.)

SERIES PREFIX \_\_\_\_\_

SHELL STYLE \_\_\_\_\_

CLASS \_\_\_\_\_

SHELL SIZE \_\_\_\_\_

HARDWARE FINISH \_\_\_\_\_

CONTACT ARRANGEMENT \_\_\_\_\_

CONTACT STYLE \_\_\_\_\_

SHELL POSITION \_\_\_\_\_

LESS CONTACTS \_\_\_\_\_

Note KJ supplied with exact complement of contacts.

#### SHELL SIZE

8, 10, 12, 14, 16, 18, 20, 22, and 24.

#### HARDWARE FINISH STANDARD

- A - Bright cadmium over electroless nickel plates, - 85°F to + 302°F (- 65°C to + 150°C)
- B - Olive drab cadmium over electroless nickel plate, - 85°F to + 347°F (- 65°C to + 175°C)
- C - Anodic (non-conductive), - 85°F to + 392°F (-65°C to + 200°C). Not applicable to KJG6.
- N - Electroless nickel, - 85°F to + 392°F (-65°C to + 200°C)

#### CONTACT ARRANGEMENT

See pages 132 and 133.

#### CONTACT STYLE

- P - Pin
- S - Socket

#### ALTERNATE SHELL POSITION

N(normal), A, B, C, D, see page 131.

#### LESS CONTACTS

Use "L" when connectors are ordered less contacts, sealing plugs and insertion/extraction tool. ("L" is not stamped on connectors.)

KJ 6 T 18 A 35 S N L



## Wall Mounting Receptacle

MS27472  
(MS service class E, P, T)

KJ0

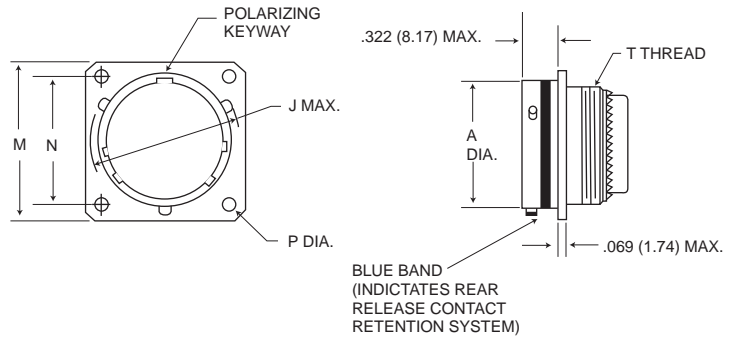

NOTE: For backshell dimensions and configurations, see page 135 and 136

Shell Size	A Dia. Max.	J Dia. Max.	M Max.	N T.P.	P +.005 (0.13) -0.10 (0.25)	T Thread	Overall length With Backshells		
							E Straight	F Cable Clamp	P Potting Max.
8	.474 (12.04)	.563 (14.30)	.828 (21.03)	.594 (15.09)	.125 (3.18)	7/16-28UNEF-2A	.850 (21.59)	1.555 (39.50)	1.020 (25.91)
10	.591 (15.01)	.680 (17.27)	.954 (24.23)	.719 (18.26)	.125 (3.18)	9/16-24UNEF-2A	.850 (21.59)	1.555 (39.50)	1.020 (25.91)
12	.751 (19.08)	.859 (21.82)	1.047 (26.59)	.812 (20.62)	.125 (3.18)	11/16-24UNEF-2A	.850 (21.59)	1.555 (39.50)	1.020 (25.91)
14	.876 (22.25)	.984 (24.99)	1.141 (28.98)	.906 (23.01)	.125 (3.18)	13/16-20UNEF-2A	.850 (21.59)	1.790 (45.47)	1.020 (25.91)
16	1.001 (25.43)	1.108 (28.14)	1.234 (31.34)	.969 (24.61)	.125 (3.18)	15/16-20UNEF-2A	.850 (21.59)	1.790 (45.47)	1.020 (25.91)
18	1.126 (28.60)	1.233 (31.32)	1.328 (33.73)	1.062 (26.97)	.125 (3.18)	1-1/16-18UNEF-2A	.850 (21.59)	1.790 (45.47)	1.020 (25.91)
20	1.251 (31.78)	1.358 (34.49)	1.453 (36.91)	1.156 (27.36)	.125 (3.18)	1-3/16-18UNEF-2A	.850 (21.59)	1.790 (45.47)	1.020 (25.91)
22	1.376 (34.95)	1.483 (37.67)	1.578 (39.08)	1.250 (31.76)	.125 (3.18)	1-5/16-18UNEF-2A	.850 (21.59)	1.930 (49.02)	1.020 (25.91)
24	1.501 (38.13)	1.610 (40.89)	1.703 (43.26)	1.375 (34.92)	.152 (3.86)	1-7/16-18UNEF-2A	.850 (21.59)	1.900 (48.26)	1.080 (27.43)

## Box Mounting Receptacle

MS27499E  
(MS service class E)

KJ2E

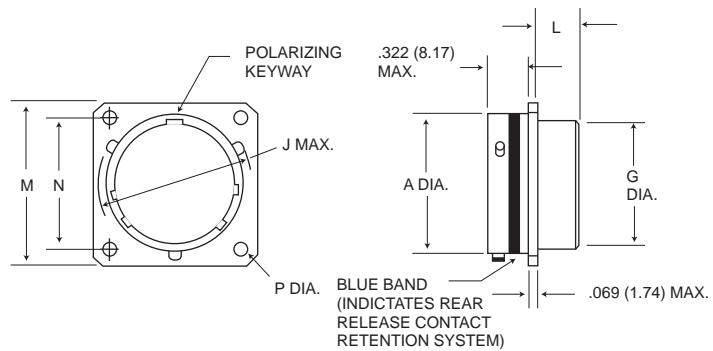

NOTE: This connector does not accommodate backshells

Shell Size	A Dia. Max.	G Dia. Max.	J Dia. Max.	L Max.	M Max.	N T.P.	P +.005 (0.13) -0.10 (0.25)
8	.474 (12.04)	.421 (10.69)	.563 (14.30)	.312 (7.92)	.828 (21.03)	.594 (15.09)	.125 (3.18)
10	.591 (15.01)	.542 (13.77)	.680 (17.27)	.312 (7.92)	.954 (24.23)	.719 (18.26)	.125 (3.18)
12	.751 (19.08)	.667 (16.94)	.859 (21.82)	.312 (7.92)	1.047 (26.59)	.812 (20.62)	.125 (3.18)
14	.876 (22.25)	.791 (20.09)	.984 (24.99)	.312 (7.92)	1.141 (28.98)	.906 (23.01)	.125 (3.18)
16	1.001 (25.43)	.916 (23.27)	1.108 (28.14)	.312 (7.92)	1.234 (31.34)	.969 (24.61)	.125 (3.18)
18	1.126 (28.60)	1.034 (26.26)	1.233 (31.32)	.312 (7.92)	1.328 (33.73)	1.062 (26.97)	.125 (3.18)
20	1.251 (31.78)	1.158 (29.41)	1.358 (34.49)	.312 (7.92)	1.453 (36.81)	1.156 (27.36)	.125 (3.18)
22	1.376 (34.95)	1.283 (32.59)	1.483 (37.67)	.312 (7.92)	1.578 (40.08)	1.250 (31.75)	.125 (3.18)
24	1.501 (38.13)	1.408 (35.76)	1.610 (40.89)	.312 (7.92)	1.703 (43.26)	1.375 (34.93)	.152 (3.86)

Performance Specifications - Pages 115-116

Contacts, Sealing Plugs, Assembly Tools - Pages 134, 136 - 137

Contact Arrangements - Pages 132 - 133

## Box Mounting Receptacle

MS27513E  
(MS service class E)

KJ2R

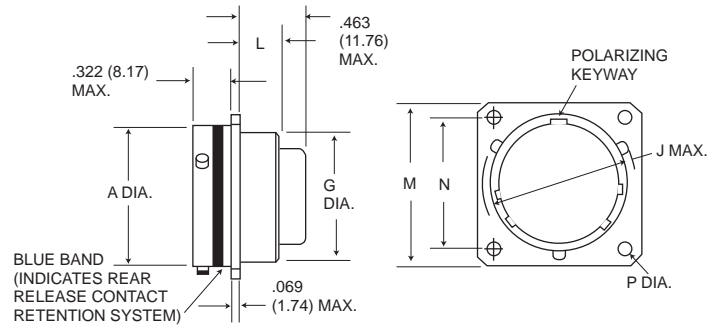

NOTE: This connector does not accommodate backshells

Shell Size	A Dia. Max.	G Dia. Max.	J Dia. Max.	L Max.	M Max.	N T.P.	P +.005 (0.13) -0.010 (0.25)
8	.474 (12.04)	.421 (10.69)	.563 (14.30)	.312 (7.92)	.828 (21.03)	.594 (15.09)	.125 (3.18)
10	.591 (15.01)	.542 (13.77)	.680 (17.27)	.312 (7.92)	.954 (24.23)	.719 (18.26)	.125 (3.18)
12	.751 (19.08)	.667 (16.94)	.859 (21.82)	.312 (7.92)	1.047 (26.59)	.812 (20.62)	.125 (3.18)
14	.876 (22.25)	.791 (20.09)	.984 (24.99)	.312 (7.92)	1.141 (28.98)	.906 (23.01)	.125 (3.18)
16	1.001 (25.43)	.916 (23.27)	1.108 (28.14)	.312 (7.92)	1.234 (31.34)	.969 (24.61)	.125 (3.18)
18	1.126 (28.60)	1.034 (26.26)	1.233 (31.32)	.312 (7.92)	1.328 (33.73)	1.062 (26.97)	.125 (3.18)
20	1.251 (31.78)	1.158 (29.41)	1.358 (34.49)	.312 (7.92)	1.453 (36.81)	1.156 (27.36)	.125 (3.18)
22	1.376 (33.95)	1.283 (32.59)	1.483 (27.67)	.312 (7.92)	1.578 (40.08)	1.250 (31.75)	.125 (3.18)
24	1.501 (38.13)	1.408 (35.76)	1.610 (40.89)	.312 (7.92)	1.703 (43.26)	1.375 (34.93)	.152 (3.85)

## Wall Mounting Receptacle

MS27497  
(MS service class E, P, T)

KJ3

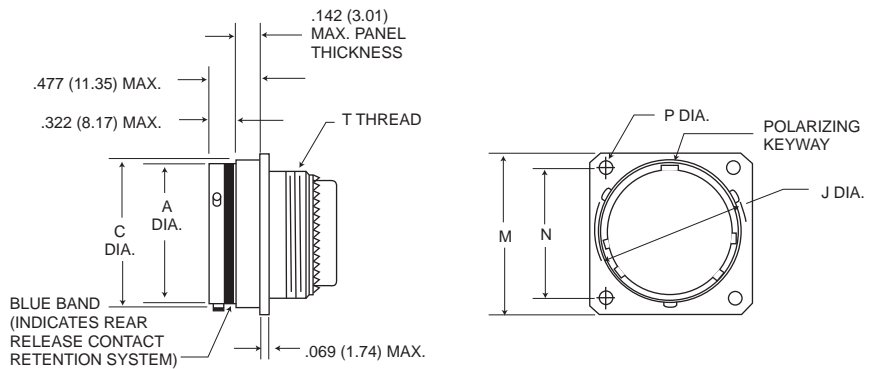

NOTE: For backshell dimensions and configurations, see page 135 and 136

Shell Size	A Dia. Max.	C Dia. Max.	J Dia. Max.	M Max.	N T.P.	P +.005 (0.13) -0.010 (0.25)	T Thread	Overall length With Backshells		
								E Straight	F Cable Clamp	P Potting Max.
8	.474 (12.04)	.522 (13.26)	.563 (14.30)	.828 (21.03)	.594 (15.09)	.125 (3.18)	7/16-28UNEF-2A	.855 (21.72)	1.570 (39.88)	1.020 (25.91)
10	.591 (15.01)	.639 (16.23)	.680 (17.27)	.954 (24.23)	.719 (18.26)	.125 (3.18)	9/16-24UNEF-2A	.855 (21.72)	1.570 (39.88)	1.020 (25.91)
12	.751 (19.08)	.808 (20.52)	.859 (21.82)	1.047 (26.59)	.812 (20.62)	.125 (3.18)	11/16-24UNEF-2A	.855 (21.72)	1.570 (39.88)	1.020 (25.91)
14	.876 (22.25)	.935 (23.75)	.984 (24.99)	1.141 (28.98)	.906 (23.01)	.125 (3.18)	13/16-20UNEF-2A	.855 (21.72)	1.780 (45.21)	1.020 (25.91)
16	1.001 (25.43)	1.058 (26.87)	1.108 (28.14)	1.234 (31.34)	.969 (24.61)	.125 (3.18)	15/16-20UNEF-2A	.855 (21.72)	1.780 (45.21)	1.020 (25.91)
18	1.126 (28.60)	1.183 (30.05)	1.233 (31.32)	1.328 (33.73)	1.062 (26.97)	.125 (3.18)	1-1/16-18UNEF-2A	.855 (21.72)	1.780 (45.21)	1.020 (25.91)
20	1.251 (31.78)	1.308 (33.22)	1.358 (34.49)	1.453 (36.91)	1.156 (29.36)	.125 (3.18)	1-3/16-18UNEF-2A	.855 (21.72)	1.780 (45.21)	1.020 (25.91)
22	1.376 (34.95)	1.433 (36.40)	1.483 (37.67)	1.578 (40.08)	1.250 (31.75)	.125 (3.18)	1-5/16-18UNEF-2A	.855 (21.72)	1.960 (49.78)	1.020 (25.91)
24	1.501 (38.13)	1.568 (39.83)	1.610 (40.89)	1.703 (43.26)	1.375 (34.93)	.152 (3.86)	1-7/16-18UNEF-2A	.855 (21.72)	1.960 (49.78)	1.080 (27.43)

Performance Specifications - Pages 115-116

Contacts, Sealing Plugs, Assembly Tools - Pages 134, 136 - 137

Contact Arrangements - Pages 132 - 133

## Box Mounting Receptacle (Back Panel)

MS27508E  
(MS service class E)

KJ5E

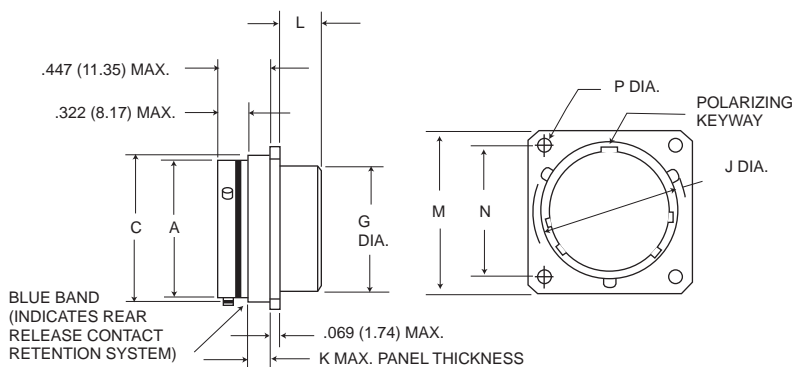

NOTE: This connector does not accommodate backshells

Shell Size	A Dia. Max.	C Dia. Max.	G Dia. Max.	J Dia. Max.	K Max.	L Max.	M Max.	N T.P.	P +.005 (0.13) -0.010 (0.25)
8	.474 (12.04)	.522 (13.26)	.421 (10.69)	.563 (14.30)	.147 (3.73)	.185 (4.70)	.828 (21.03)	.594 (15.09)	.125 (3.18)
10	.591 (15.01)	.639 (16.23)	.542 (13.77)	.680 (17.27)	.152 (3.86)	.185 (4.70)	.954 (24.23)	.719 (18.26)	.125 (3.18)
12	.751 (19.08)	.808 (20.52)	.667 (16.94)	.859 (21.82)	.152 (3.86)	.185 (4.70)	1.047 (26.59)	.812 (20.62)	.125 (3.18)
14	.876 (22.25)	.935 (23.75)	.791 (20.09)	.984 (24.99)	.152 (3.86)	.185 (4.70)	1.141 (28.98)	.906 (23.01)	.125 (3.18)
16	1.001 (25.42)	1.058 (26.87)	.916 (23.27)	1.108 (28.14)	.152 (3.86)	.185 (4.70)	1.234 (31.24)	.969 (24.61)	.125 (3.18)
18	1.126 (28.60)	1.183 (30.05)	1.034 (31.34)	1.233 (31.32)	.152 (3.86)	.185 (4.70)	1.328 (33.73)	1.062 (26.97)	.125 (3.18)
20	1.251 (31.77)	1.308 (33.22)	1.158 (34.52)	1.358 (34.49)	.179 (4.55)	.185 (4.70)	1.453 (36.91)	1.156 (29.36)	.125 (3.18)
22	1.376 (34.95)	1.433 (36.40)	1.283 (32.59)	1.483 (37.67)	.179 (4.55)	.185 (4.70)	1.578 (40.08)	1.250 (31.75)	.125 (3.18)
24	1.501 (38.13)	1.568 (39.83)	1.408 (35.76)	1.610 (40.89)	.169 (4.29)	.185 (4.70)	1.703 (43.66)	1.375 (34.92)	.152 (3.86)

## Box Mounting Receptacle (Back Panel)

No MS part number

KJ5R

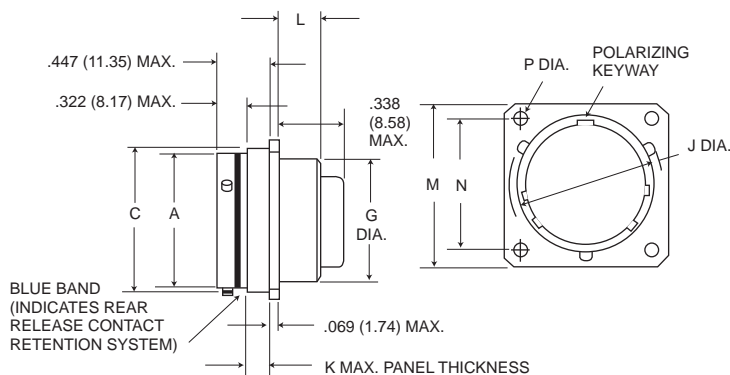

NOTE: This connector does not accommodate backshells

Shell Size	A Dia. Max.	C Dia. Max.	G Dia. Max.	J Dia. Max.	K Max.	L Max.	M Max.	N T.P.	P +.005 (0.13) -0.010 (0.25)
8	.474 (12.04)	.522 (13.26)	.421 (10.69)	.563 (14.30)	.147 (3.73)	.185 (4.70)	.828 (21.03)	.594 (15.09)	.125 (3.18)
10	.591 (15.01)	.639 (16.23)	.542 (13.77)	.680 (17.27)	.152 (3.86)	.185 (4.70)	.954 (24.23)	.719 (18.26)	.125 (3.18)
12	.751 (19.08)	.808 (20.52)	.667 (16.94)	.859 (21.82)	.152 (3.86)	.185 (4.70)	1.047 (26.59)	.812 (20.62)	.125 (3.18)
14	.876 (22.25)	.935 (23.75)	.791 (20.09)	.984 (24.99)	.152 (3.86)	.185 (4.70)	1.141 (28.98)	.906 (23.01)	.125 (3.18)
16	1.001 (25.42)	1.058 (26.87)	.916 (23.27)	1.108 (28.14)	.152 (3.86)	.185 (4.70)	1.234 (31.24)	.969 (24.61)	.125 (3.18)
18	1.126 (28.60)	1.183 (30.05)	1.034 (31.34)	1.233 (31.32)	.152 (3.86)	.185 (4.70)	1.328 (33.73)	1.062 (26.97)	.125 (3.18)
20	1.251 (31.77)	1.308 (33.22)	1.158 (34.52)	1.358 (34.49)	.179 (4.55)	.185 (4.70)	1.453 (36.91)	1.156 (29.36)	.125 (3.18)
22	1.376 (34.95)	1.433 (36.40)	1.283 (32.59)	1.483 (37.67)	.179 (4.55)	.185 (4.70)	1.578 (40.08)	1.250 (31.75)	.125 (3.18)
24	1.501 (38.13)	1.568 (39.83)	1.408 (35.76)	1.610 (40.89)	.169 (4.29)	.185 (4.70)	1.703 (43.66)	1.375 (34.92)	.152 (3.86)

Performance Specifications - Pages 115-116

Contacts, Sealing Plugs, Assembly Tools - Pages 134, 136 - 137

Contact Arrangements - Pages 132 - 133

## Straight Plug

MS27473  
(MS service class E, P, T)

KJ6

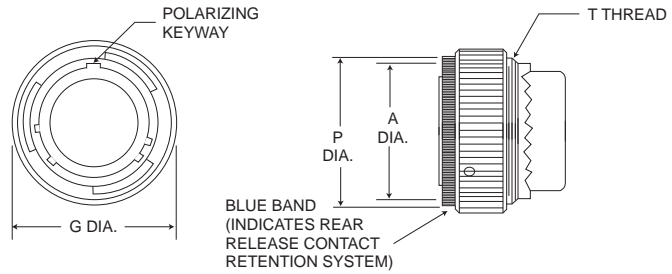

NOTE: For backshell dimensions and configurations, see pages 135 and 136.

Shell Size	A Dia. Max.	G Dia. Max.	P Dia. Max.	T Thread	Overall Length With Backshells		
					E Straight	F Cable Clamp	P Potting Max.
8	.485 (12.32)	.749 (19.02)	.630 (16.00)	7/16-28UNEF-2A	1.026 (26.06)	1.555 (39.50)	1.020 (25.91)
10	.606 (15.39)	.858 (21.79)	.752 (19.10)	9/16-24UNEF-2A	1.026 (26.06)	1.555 (39.50)	1.020 (25.91)
12	.765 (19.43)	1.030 (26.16)	.925 (23.50)	11/16-24UNEF-2A	1.026 (26.06)	1.555 (39.50)	1.020 (25.91)
14	.890 (22.61)	1.155 (29.34)	1.050 (26.67)	13/16-20UNEF-2A	1.026 (26.06)	1.790 (45.47)	1.020 (25.91)
16	1.014 (25.76)	1.280 (32.51)	1.172 (29.77)	15/16-20UNEF-2A	1.026 (26.06)	1.790 (45.47)	1.020 (25.91)
18	1.140 (28.96)	1.405 (35.69)	1.304 (33.12)	1-1/16-18UNEF-2A	1.026 (26.06)	1.790 (45.47)	1.020 (25.91)
20	1.264 (32.11)	1.530 (38.86)	1.435 (36.45)	1-3/16-18UNEF-2A	1.026 (26.06)	1.790 (45.47)	1.020 (25.91)
22	1.389 (35.28)	1.640 (40.66)	1.560 (39.62)	1-5/16-18UNEF-2A	1.026 (26.06)	1.930 (49.02)	1.020 (25.91)
24	1.514 (38.46)	1.765 (44.83)	1.688 (42.88)	1-7/16-18UNEF-2A	1.104 (28.04)	1.930 (49.02)	1.080 (27.43)

## Straight Plug Grounded

MS27484  
(MS service class E, P, T)

KJG6

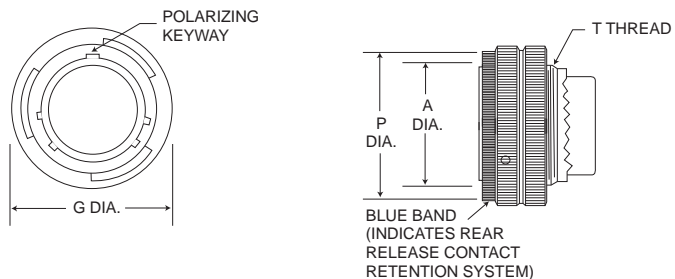

NOTE: For backshell dimensions and configurations, see pages 135 and 136.

Shell Size	A Dia. Max.	G Dia. Max.	P Dia. Max.	T Thread	Overall Length With Backshells		
					E Straight	F Cable Clamp	P Potting Max.
8	.485 (12.32)	.749 (19.02)	.630 (16.00)	7/16-28UNEF-2A	1.026 (26.06)	1.555 (39.50)	1.020 (25.91)
10	.606 (15.39)	.858 (21.79)	.752 (19.10)	9/16-24UNEF-2A	1.026 (26.06)	1.555 (39.50)	1.020 (25.91)
12	.765 (19.43)	1.030 (26.16)	.925 (23.50)	11/16-24UNEF-2A	1.026 (26.06)	1.555 (39.50)	1.020 (25.91)
14	.890 (22.61)	1.155 (29.34)	1.050 (26.67)	13/16-20UNEF-2A	1.026 (26.06)	1.790 (45.47)	1.020 (25.91)
16	1.014 (25.76)	1.280 (32.51)	1.172 (29.77)	15/16-20UNEF-2A	1.026 (26.06)	1.790 (45.47)	1.020 (25.91)
18	1.140 (28.96)	1.405 (35.69)	1.304 (33.12)	1-1/16-18UNEF-2A	1.026 (26.06)	1.790 (45.47)	1.020 (25.91)
20	1.264 (32.11)	1.530 (38.86)	1.435 (36.45)	1-3/16-18UNEF-2A	1.026 (26.06)	1.790 (45.47)	1.020 (25.91)
22	1.389 (35.28)	1.640 (40.66)	1.560 (39.62)	1-5/16-18UNEF-2A	1.026 (26.06)	1.930 (49.02)	1.020 (25.91)
24	1.514 (38.46)	1.765 (44.83)	1.688 (42.88)	1-7/16-18UNEF-2A	1.104 (28.04)	1.930 (49.02)	1.080 (27.43)

Performance Specifications - Pages 115-116

Contacts, Sealing Plugs, Assembly Tools - Pages 134, 136 - 137

Contact Arrangements - Pages 132 - 133

## Straight Plug

MS27474  
(MS service class E, P, T)

KJ7

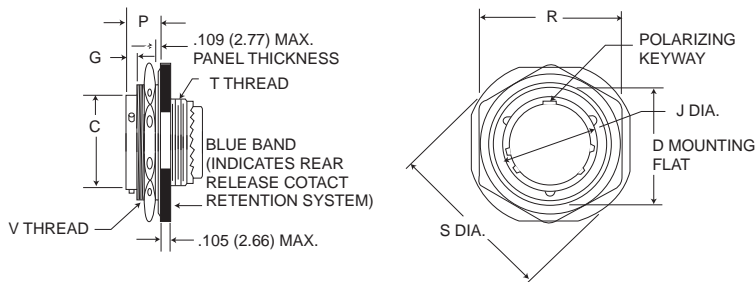

NOTE: For backshell dimensions and configurations, see pages 135 and 136.

Shell Size	C Dia. Max.	D Max.	G Max.	J Max.	P Max.	R Max. Hex.	S Dia. Max.	T Thread	V Thread	Overall length With Backshells		
										E Straight	F Cable Clamp	P Potting Max.
8	.474 (12.04)	.818 (20.78)	.145 (3.68)	.563 (14.30)	.443 (11.25)	1.079 (27.41)	1.381 (35.08)	7/16-28UNEF-2A	7/8-20UNEF-2A	.840 (21.34)	1.555 (39.50)	1.020 (25.91)
10	.591 (15.01)	.942 (23.93)	.145 (3.68)	.680 (17.27)	.443 (11.25)	1.205 (30.61)	1.506 (38.25)	9/16-24UNEF-2A	1-20UNEF-2A	.840 (21.34)	1.555 (39.50)	1.020 (25.91)
12	.751 (19.08)	1.066 (27.08)	.145 (3.68)	.859 (21.82)	.443 (11.25)	1.329 (33.76)	1.631 (41.43)	11/16-24UNEF-2A	1-1/8-18UNEF-2A	.840 (21.34)	1.555 (39.50)	1.020 (25.91)
14	.876 (22.25)	1.191 (30.25)	.145 (3.68)	.984 (24.99)	.443 (11.25)	1.455 (36.96)	1.756 (44.60)	13/16-20UNEF-2A	1-1/4-18UNEF-2A	.840 (21.34)	1.790 (45.47)	1.020 (25.91)
16	1.001 (25.43)	1.321 (33.55)	.145 (3.68)	1.108 (28.14)	.443 (11.25)	1.579 (40.11)	1.944 (49.38)	1-15/16-20UNEF-2A	1-3/8-18UNEF-2A	.840 (21.34)	1.790 (45.47)	1.020 (25.91)
18	1.126 (28.60)	1.441 (36.60)	.145 (3.68)	1.233 (31.32)	.443 (11.25)	1.705 (43.31)	2.022 (51.36)	1-1/16-18UNEF-2A	1-1/2-18UNEF-2A	.840 (21.34)	1.790 (45.47)	1.020 (25.91)
20	1.251 (31.78)	1.566 (39.78)	.171 (4.34)	1.358 (34.49)	.469 (11.91)	1.829 (46.46)	2.147 (54.53)	1-3/16-18UNEF-2A	1-5/8-18UNEF-2A	.840 (21.34)	1.790 (45.47)	1.020 (25.91)
22	1.376 (33.95)	1.691 (42.95)	.171 (4.34)	1.483 (37.67)	.469 (11.91)	2.017 (51.23)	2.271 (57.68)	1-5/16-18UNEF-2A	1-3/4-18UNEF-2A	.840 (21.34)	1.930 (49.02)	1.020 (25.91)
24	1.501 (38.13)	1.816 (46.13)	.171 (4.34)	1.610 (40.89)	.469 (11.91)	2.142 (54.41)	2.396 (60.86)	1-7/16-18UNEF-2A	1-7/8-18UNEF-2A	.860 (21.84)	1.900 (48.26)	1.080 (27.43)

Performance Specifications - Pages 115-116

Contacts, Sealing Plugs, Assembly Tools - Pages 134, 136 - 137

Contact Arrangements - Pages 132 - 133

## Panel Cutouts

### Flange Mounted Receptacle

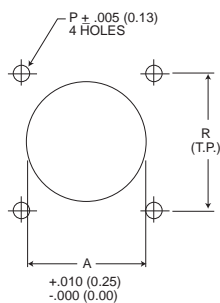

### Jam Nut Receptacle

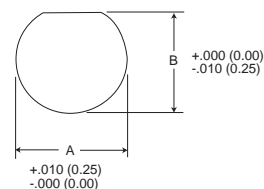

Shell Size	A Dia.	P Dia.	R	Mfg. Screw
8	.610 (15.49)	.125 (3.18)	.594 (15.09)	#4
10	.734 (18.64)	.125 (3.18)	.719 (18.26)	#4
12	.860 (21.84)	.125 (3.18)	.812 (20.62)	#4
14	.985 (25.02)	.125 (3.18)	.906 (23.01)	#4
16	1.110 (28.19)	.125 (3.18)	.969 (24.61)	#4
18	1.234 (31.34)	.125 (3.18)	1.062 (26.97)	#4
20	1.360 (35.54)	.125 (3.18)	1.156 (29.36)	#4
22	1.484 (37.69)	.125 (3.18)	1.250 (31.75)	#4
24	1.611 (40.92)	.152 (3.86)	1.375 (34.93)	#6

Shell Size	A Dia.	B Dia.
8	.885 (22.48)	.830 (21.08)
10	1.010 (25.65)	.955 (24.26)
12	1.135 (28.82)	1.085 (27.56)
14	1.260 (32.00)	1.210 (30.73)
16	1.385 (35.18)	1.335 (33.91)
18	1.510 (38.35)	1.460 (37.08)
20	1.635 (41.53)	1.585 (40.26)
22	1.760 (44.70)	1.710 (43.43)
24	1.885 (47.88)	1.835 (46.61)

## How To Order

### Military Nomenclature

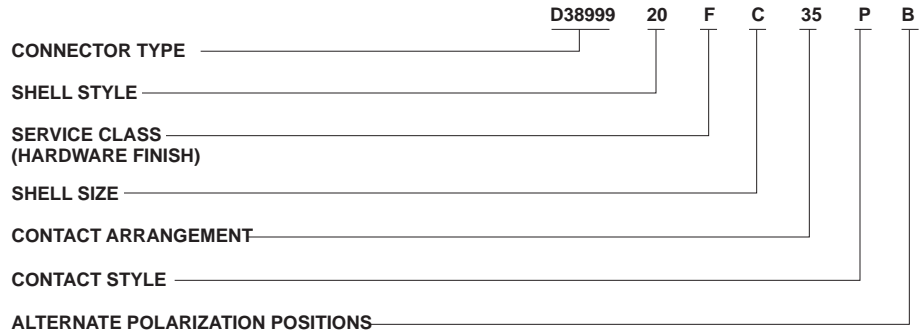

**CONNECTOR TYPE**  
D38999/ - MIL-C-38999 Series III

**SHELL STYLE**  
D38999/20 - Wall mount receptacle  
D38999/24 - Jam nut receptacle  
D38999/26 - Straight Plug, Grounded

**SERVICE CLASS**  
(Hardware Finish)  
F - Electroless nickel - 85°F to +392°F (-65°C to +200°C)  
W - Olive drab cadmium over electroless nickel plate, -85°F to +347°F (-65°C to +175°C)

**SHELL SIZE**

A	B	C	D	E	F	G	H	J	Military Designation
9	11	13	15	17	19	21	23	25	Cannon Designation

**CONTACT ARRANGEMENTS**

See pages 132 and 133.

**CONTACT STYLE**

- P - Pin contacts
- S - Socket contact
- A - Less Pin contacts
- B - Less Socket contact\*

See pages 296-298 for Fiber Optic Contacts.

\* Used only when other than power contacts are to be installed (i.e., shielded, thermocouple, etc.)

**ALTERNATE POSITIONS**

N (normal), A, B, C, D, E. See page 131.

Note: To order MS connectors less standard power contacts, purchase order must state "Less Contacts".

### ITT Cannon Nomenclature

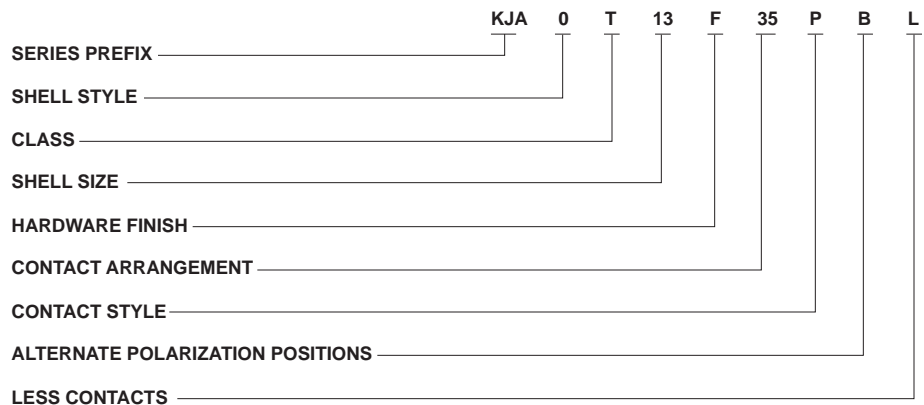

**SERIES PREFIX**

KJA - Series III - Scoop proof, threaded coupling

**SHELL STYLE**

- 0 - Wall mount receptacle
- 6 - Straight plug
- 7 - Jam nut receptacle

**CLASS**

T - Environment-resistant (without rear accessory)

**SHELL SIZE**

9	11	13	15	17	19	21	23	25	Cannon Designation
A	B	C	D	E	F	G	H	J	Military Designation

**HARDWARE FINISH**

F - Electroless nickel - 85°F to +392°F (-65°C to +200°C)  
W - Olive drab cadmium over electroless nickel plate, -85°F to +347°F (-65°C to +175°C)

**CONTACT ARRANGEMENTS**

See pages 132 and 133.

**CONTACT STYLE**

- P - Pin contacts
  - S - Socket contacts
- See pages 296-298 for Fiber Optic Contacts

**ALTERNATE POLARIZATION POSITIONS**

N (normal) A, B, C, D, E. See page 131.

**LESS CONTACTS**

Use "L" when connectors are ordered less contacts, sealing plugs and insertion/extraction tool. ("L" is not stamped on connectors.)

## Wall Mount Receptacle

D38999/20

KJA0T\*\*

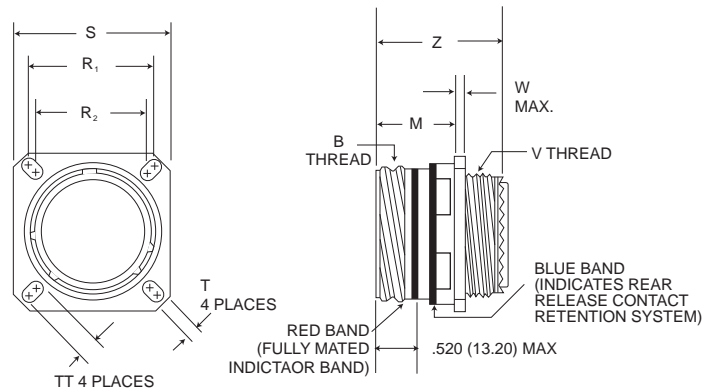

Shell Size	MS Shell size Code	B Thread Class 2A (Plated)	M +.000 (.000) -.005 (.130)	R <sub>1</sub>	R <sub>2</sub>	S ±.012 (.300)	T +.004 (.100) -.002 (.050)	TT +.004 (.100) -.002 (.050)	Metric V Thread (Plated)	W Max.	Z +.005 (.130) -.010 (.250)
9	A	.6250-0.1P-0.3L-TS	.820 (20.83)	.719 (18.26)	.594 (15.09)	.938 (23.83)	.128 (3.25)	.216 (5.49)	M12X1-6g0.100R	.098 (2.50)	1.235 (31.36)
11	B	.7500-0.1P-0.3L-TS	.820 (20.83)	.812 (20.62)	.719 (18.26)	1.031 (26.19)	.128 (3.25)	.194 (4.93)	M15X1-6g0.100R	.098 (2.50)	1.235 (31.36)
13	C	.8750-0.1P-0.3L-TS	.820 (20.83)	.906 (23.01)	.812 (20.62)	1.125 (28.58)	.128 (3.25)	.194 (4.93)	M18X1-6g0.100R	.098 (2.50)	1.235 (31.36)
15	D	1.0000-0.1P-0.3L-TS	.820 (20.83)	.969 (24.61)	.906 (23.01)	1.219 (30.96)	.128 (3.25)	.173 (4.39)	M22X1-6g0.100R	.098 (2.50)	1.235 (31.36)
17	E	1.1875-0.1P-0.3L-TS	.820 (20.83)	1.062 (26.97)	.969 (24.61)	1.312 (33.32)	.128 (3.25)	.194 (4.93)	M25X1-6g0.100R	.098 (2.50)	1.235 (31.36)
19	F	1.2500-0.1P-0.3L-TS	.820 (20.83)	1.156 (29.36)	1.062 (26.97)	1.438 (36.53)	.128 (3.25)	.194 (4.93)	M28X1-6g0.100R	.098 (2.50)	1.235 (31.36)
21	G	1.3750-0.1P-0.3L-TS	.790 (20.07)	1.250 (31.75)	1.156 (29.36)	1.562 (39.67)	.128 (3.25)	.194 (4.93)	M31X1-6g0.100R	.126 (3.20)	1.235 (31.36)
23	H	1.5000-0.1P-0.3L-TS	.790 (20.07)	1.375 (34.92)	1.250 (31.75)	1.688 (42.88)	.154 (3.91)	.242 (6.15)	M34X1-6g0.100R	.126 (3.20)	1.235 (31.36)
25	J	1.6250-0.1P-0.3L-TS	.790 (20.07)	1.500 (38.10)	1.375 (34.92)	1.812 (46.02)	.154 (3.91)	.242 (6.15)	M37X1-6g0.100R	.126 (3.20)	1.235 (31.36)

## Straight Plug Grounded

D38999/26

KJA6T\*\*

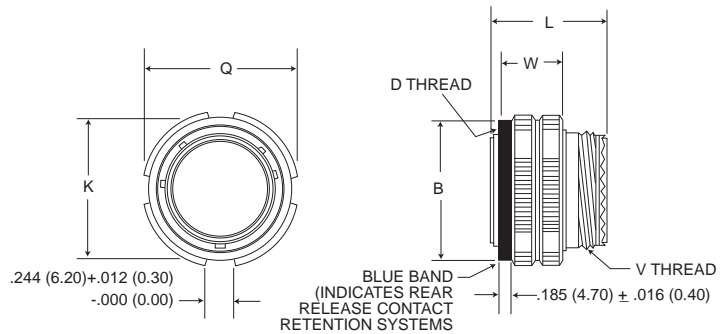

Shell Size	MS Shell size Code	B +.008 (.200) -.000 (.000)	D Thread Class 2B (Plated)	K Max.	L Max.	Q Dia Max.	Metric V Thread (Plated)	W +.008 (.200) -.004 (.100)
9	A	.724 (18.40)	.6250-0.1P-0.3L-TS	.748 (19.00)	1.234 (31.34)	.859 (21.82)	M12X1-6g0.100R	.760 (19.30)
11	B	.831 (21.10)	.7500-0.1P-0.3L-TS	.862 (21.90)	1.234 (31.34)	.969 (24.61)	M15X1-6g0.100R	.760 (19.30)
13	C	1.000 (25.40)	.8750-0.1P-0.3L-TS	1.027 (26.10)	1.234 (31.34)	1.141 (28.98)	M18X1-6g0.100R	.760 (19.30)
15	D	1.130 (28.70)	1.0000-0.1P-0.3L-TS	1.153 (29.30)	1.234 (31.34)	1.266 (32.16)	M22X1-6g0.100R	.760 (19.30)
17	E	1.268 (32.20)	1.1845-0.1P-0.3L-TS	1.291 (32.80)	1.234 (31.34)	1.391 (35.53)	M25X1-6g0.100R	.760 (19.30)
19	F	1.374 (34.90)	1.2500-0.1P-0.3L-TS	1.398 (35.50)	1.234 (31.34)	1.500 (38.10)	M28X1-6g0.100R	.760 (19.30)
21	G	1.500 (38.10)	1.3750-0.1P-0.3L-TS	1.524 (38.70)	1.234 (31.34)	1.625 (41.28)	M31X1-6g0.100R	.760 (19.30)
23	H	1.618 (41.40)	1.5000-0.1P-0.3L-TS	1.642 (41.70)	1.234 (31.34)	1.750 (44.45)	M34X1-6g0.100R	.760 (19.30)
25	J	1.744 (44.30)	1.6250-0.1P-0.3L-TS	1.768 (44.90)	1.234 (31.34)	1.875 (47.62)	M37X1-6g0.100R	.760 (19.30)

Performance Specifications - Pages 115-116

Contacts, Sealing Plugs, Assembly Tools - Pages 134, 136-137

Contact Arrangements - Pages 132 - 133

## Jam Nut Receptacle

D38999/24

KJA7T\*\*\*

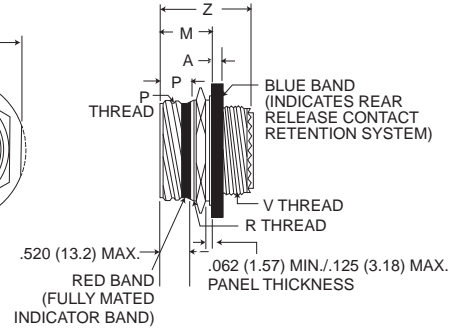
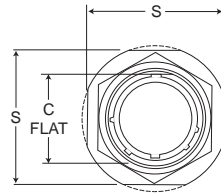

Shell Size	MS Shell size Code	A +.010 (.250) -.005 (.130)	B Thread Class 2A (Plated)	C +.004 (.100) -.010 (.250)	Z +.005 (.130) -.040 (.100)	M +.005 (.130) -.004 (.100)	P +.016 (.410) -.004 (.100)	S	Metric R Thread (Plated)	Metric V Thread (Plated)
9	A	.104 (2.64)	.6250-0.1P-0.3L-TS	.651 (16.53)	1.243 (31.57)	.871 (22.12)	.555 (14.10)	1.062 (26.97)	M17X1-6g0.100R	M12X1-6g0.100R
11	B	.104 (2.64)	.7500-0.1P-0.3L-TS	.751 (19.07)	1.243 (31.57)	.871 (22.12)	.555 (14.10)	1.250 (31.75)	M20X1-6g0.100R	M15X1-6g0.100R
13	C	.104 (2.64)	.8750-0.1P-0.3L-TS	.938 (23.82)	1.243 (31.57)	.878 (22.30)	.563 (14.30)	1.375 (34.92)	M25X1-6g0.100R	M18X1-6g0.100R
15	D	.104 (2.64)	1.0000-0.1P-0.3L-TS	1.062 (26.97)	1.243 (31.57)	.878 (22.30)	.563 (14.30)	1.500 (38.10)	M28X1-6g0.100R	M22X1-6g0.100R
17	E	.104 (2.64)	1.1875-0.1P-0.3L-TS	1.187 (30.15)	1.243 (31.57)	.878 (22.30)	.563 (14.30)	1.625 (41.28)	M32X1-6g0.100R	M25X1-6g0.100R
19	F	.135 (3.43)	1.2500-0.1P-0.3L-TS	1.312 (33.32)	1.243 (31.57)	.878 (22.30)	.563 (14.30)	1.812 (46.02)	M35X1-6g0.100R	M28X1-6g0.100R
21	G	.135 (3.43)	1.3750-0.1P-0.3L-TS	1.437 (36.50)	1.243 (31.57)	.878 (22.30)	.563 (14.30)	1.938 (49.23)	M38X1-6g0.100R	M31X1-6g0.100R
23	H	.135 (3.43)	1.5000-0.1P-0.3L-TS	1.562 (39.67)	1.243 (31.57)	.878 (22.30)	.563 (14.30)	2.062 (52.37)	M41X1-6g0.100R	M34X1-6g0.100R
25	J	.135 (3.43)	1.6250-0.1P-0.3L-TS	1.687 (42.85)	1.243 (31.57)	.878 (22.30)	.563 (14.30)	2.188 (55.38)	M44X1-6g0.100R	M37X1-6g0.100R

Performance Specifications - Pages 115-116

Contacts, Sealing Plugs, Assembly Tools - Pages 134, 136-137

Contact Arrangements - Pages 132 - 133

## Panel Cutouts

Wall Mounted Receptacle

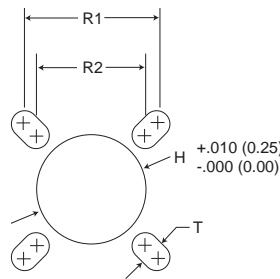

Jam Nut Receptacle

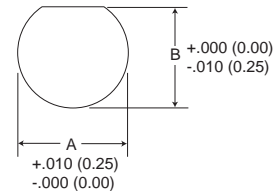

Shell Size	A	B	H	R1 (TP)	R2 (TP)	T (Max.)
9	.700 (17.78)	.670 (17.02)	.626 (15.90)	.719 (18.26)	.594 (15.09)	.134 (3.40)
11	.825 (20.26)	.770 (19.59)	.751 (19.08)	.812 (20.62)	.719 (18.26)	.134 (3.40)
13	1.01 (25.65)	.955 (24.26)	.876 (22.25)	.906 (23.01)	.812 (20.62)	.134 (3.40)
15	1.135 (28.83)	1.085 (27.56)	1.001 (24.43)	.969 (24.61)	.906 (23.01)	.134 (3.40)
17	1.260 (32.01)	1.210 (30.73)	1.188 (30.18)	1.062 (26.97)	.969 (24.61)	.134 (3.40)
19	1.385 (35.18)	1.335 (33.91)	1.251 (31.78)	1.156 (29.36)	1.062 (26.97)	.134 (3.40)
21	1.510 (38.35)	1.460 (37.08)	1.376 (34.95)	1.250 (31.75)	1.156 (29.36)	.134 (3.40)
23	1.635 (41.53)	1.585 (40.26)	1.511 (38.38)	1.375 (34.92)	1.250 (31.75)	.160 (4.06)
25	1.760 (44.70)	1.710 (43.43)	1.626 (41.30)	1.500 (38.10)	1.375 (34.92)	.160 (4.06)



**Polarizing Positions**

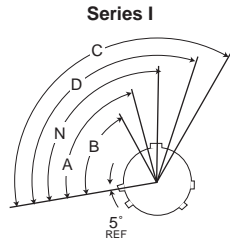

Front face of receptacle (plug opposite). Insert arrangement does not rotate with main key-keyway. The master key is rotated to provide shell polarization; the minor keys remain fixed.

Shell Size	Angle of Rotation (Degrees)				
	Normal	A	B	C	D
9	95°	77°	-	-	113°
11	95°	81°	67°	123°	109°
13	95°	75°	63°	127°	115°
15	95°	74°	61°	129°	116°
17	95°	77°	65°	125°	113°
19	95°	77°	65°	125°	113°
21	95°	77°	65°	125°	113°
23	95°	80°	69°	121°	110°
25	95°	80°	69°	121°	110°

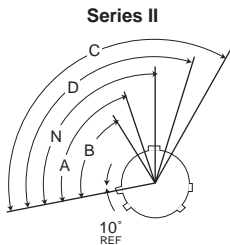

Front face of receptacle (plug opposite). Insert arrangement does not rotate with main key-keyway. The master key is rotated to provide shell polarization; the minor keys remain fixed.

Shell Size	Angle of Rotation (Degrees)				
	Normal	A	B	C	D
8	100°	82°	-	-	118°
10	100°	86°	72°	128°	114°
12	100°	80°	68°	132°	120°
14	100°	79°	66°	134°	121°
16	100°	82°	70°	130°	118°
18	100°	82°	70°	130°	118°
20	100°	82°	70°	130°	118°
22	100°	85°	74°	126°	115°
24	100°	85°	74°	126°	115°

**Series III**

**RECEPTACLE**  
(Front face shown)

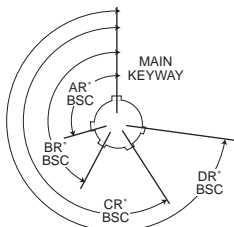

**PLUG**  
(Front face shown)

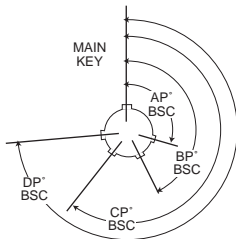

**NOTES:**

1. All Angles are BSC
2. The insert arrangement does not rotate with main key/keyway
3. All minor keys are rotated to provide shell polarization, the master key remains fixed at twelve o'clock position.
4. Polarization is different from Series I and II.

Shell Size	Key & Keyway Arrangement identification Letter	Key Locations			
		AR° or AP° BSC	BR° or BP° BSC	CR° or CP° BSC	DR° or DP° BSC
9	N	105	140	215	265
	A	102	132	248	320
	B	80	118	230	312
	C	35	140	205	275
	D	64	155	234	304
11	E	91	131	197	240
	N	95	141	208	236
	A	113	156	182	292
	B	90	145	195	252
	C	53	156	220	255
13	D	119	146	176	298
	E	51	141	184	242
	N	80	142	196	293
	A	135	170	200	310
	B	49	169	200	244
15	C	66	140	200	257
	D	62	145	180	280
	E	79	153	197	272
	N	80	142	196	293
	A	135	170	200	310
17	B	49	169	200	244
	C	66	140	200	257
	D	62	145	180	280
	E	79	153	197	272
	N	80	142	196	293
19	A	135	170	200	310
	B	49	169	200	244
	C	66	140	200	257
	D	62	145	180	280
	E	79	153	197	272
21	A	135	170	200	310
	B	49	169	200	244
	C	66	140	200	257
	D	62	145	180	280
	E	79	153	197	272
23	A	135	170	200	310
	B	49	169	200	244
	C	66	140	200	257
	D	62	145	180	280
	E	79	153	197	272
25	A	135	170	200	310
	B	49	169	200	244
	C	66	140	200	257
	D	62	145	180	280
	E	79	153	197	272

## Contact Arrangements (Engaging View Pin Insert)

\* Socket insert only

\*\* Pin insert only (Not available in socket insert Series I and III)

† Indicates layouts are available in all shell styles including MS27499, MS27508, KJ2E and KJ5E

• Consult factory MS27505E/KJL5E insert availability

For "inactive", use - 35 layout.

	Inactive			Inactive								
Series III	-	9-98	9-35	-	11-5	-	11-98	-	11-35	-	-	13-8
Series II	8-6†	8-98†	8-35†	-	10-5†	10-13†	10-98†	10-99†	10-35†	12-3	12-4†	12-8†
Series I	9-6**	9-98	9-35	11-4	11-5	11-13**	11-98	11-99	11-35	-	13-4**	13-8
No. of Contacts	6 #22M	3 #20	6 #22D	4 #20	5 #20	13 #22M	6 #20	7 #20	13 #22D	3 #16	4 #16	8 #20
Service Ratings	M	I	M	I	I	M	I	I	M	II	I	I

	Inactive							Inactive		
Series III	13-98	-	13-35	15-5	15-15	15-18	15-19	15-35	-	-
Series II	12-98†	12-22†	12-35†	14-5†	14-15†	14-18†	-	14-35†	14-37†	14-37†
Series I	13-98	13-22**	13-35	15-5	15-15	15-18	15-19	15-35	15-37**	15-37**
No. of Contacts	10 #20	22 #22M	22 #22D	5 #16	14 #20, 1 #16	18 #20	19 #20	37 #22D	37 #22M	37 #22M
Service Ratings	I	M	M	II	I	I	I	M	M	M

	Inactive		Inactive					Inactive	
Series III	15-97	17-6	17-8	17-26	17-35	-	-	-	
Series II	14-97†	16-6	16-8†	16-26†	16-35†	16-42†	16-55†	16-99†	
Series I	15-97	17-6	17-8	17-26	17-35	17-35	17-55**	17-99**	
No. of Contacts	8 #20, 4 #16	6 #12	8 #16	26 #20	55 #22D	42 #22	55 #22M	21 #20, 2 #16	
Service Ratings	I	I	II	I	M	M	M	I	

	Inactive				Inactive	
Series III	18-28	18-30	19-11	19-32	19-35	18-53
Series II	19-28**	19-30**	18-11	18-32†	18-35†	-
Series I	19-28**	19-30**	19-11	19-32	19-35	-
No. of Contacts	26 #20, 2 #16	29 #20, 1 #16	11 #16	32 #20	66 #22D	53 #22
Service Ratings	I	I	II	I	M	M

	Inactive		Inactive		Inactive	
Series III	21-11	21-16	21-35	21-39	21-41	21-41
Series II	20-1†	20-2†	20-16†	20-35†	20-39†	20-41†
Series I	21-1**	-	21-16	21-35	21-39	21-41
No. of Contacts	79 #22M	65 #22	11 #12	16 #16	79 #22D	37 #20, 2 #16
Service Ratings	M	M	I	II	M	I

	Inactive		Inactive		Inactive	
Series III	21-75	22-21	22-21	22-32	23-35	23-35
Series II	-	22-1†	22-21	22-32	22-35†	22-35†
Series I	21-75*	23-1**	23-2**	23-32**	23-35	23-35
No. of Contacts	4 #8 Twinax	100 #22M	85 #22	21 #16	32 #20	100 #22D
Service Ratings	M	M	M	II	I	M

Please consult factory for availability of layouts not shown.

Contact Arrangements (Engaging View Pin Insert)

\* Socket insert only

\*\* Pin insert only (Not available in socket insert Series I and III)

† Indicates layouts are available in all shell styles including MS27499, MS27508, KJ2E and KJ5E

• Consult factory for MS27505E/KJL5E insert availability for "inactive" layout, use-35.

		Inactive	Inactive	
Series III	23-53	23-55	-	25-4
Series II	22-53†	22-55†	24-1†	24-4†
Series I	23-53	23-55	25-1**	25-4
No. of Contacts	53 #20	55 #20	128 #22M	48 #20,8 #16
Service Ratings	I	I	M	I

Series III	25-8	25-19	25-20	25-24	25-29
Series II	-	-	-	24-24†	24-29†
Series I	25-8*•	25-19	25-20*•	25-24	25-29
No. of Contacts	8 #8 Coax/Twinax	19 #12	3 #8 Twinax, 13 #16, 4 #12 Coax, 10 #20	12 #16,12 #12	29 #16
Service Ratings	Coax	I	N	I	I

Series III	25-35	25-37	25-42	25-43	25-46
Series II	24-35†	-	-	-	-
Series I	25-35	25-37*•	25-42*•	25-43	25-46
No. of Contacts	128 #22D	37 #16	38 #20,4 #8 Coax	23 #20,20 #16	40 #20,4 #16,2 #8 coax
Service Ratings	M	I	I, Coax	I	coax

Series III	25-61	25-64*	25-66*
Series II	24-61†	-	-
Series I	25-61	25-64*	25-66*
No. of Contacts	61 #20	40 #22D,8 #20 10 #16,6 #12	53 #22D,2 #20,11 #16
Service Rating	I	I	I

Please consult factory for availability of layouts not shown.

## Contacts-Pin (Series I/II/III)

MIL-C-39029/58

KJL/KJ/KJA

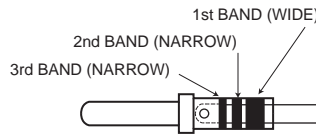

Conact Size	1	Color Bands 2	3	Cannon Part Number	M39029 Military Part Number	Superseded Military Part Number
22D	Orange	Blue	Black	030-2042-000	M39029/58-360	MS27493-22D
*22M	Orange	Blue	Brown	030-1993-022	M39029/58-361	MS27493-22M
*22	Orange	Blue	Red	030-1999-022	M39029/58-362	MS27493-22
20	Orange	Blue	Orange	030-1997-020	M39029/58-363	MS27493-20
16	Orange	Blue	Yellow	030-1995-016	M39029/58-364	MS27493-16
12	Orange	Blue	Green	030-2155-000	M39029/58-365	MS27493-12

\*Inactive for new design.

## Contacts-Socket (Series II)

MIL-C-39029/57

KJ

Manufacture identification Code Area - Typical all contacts

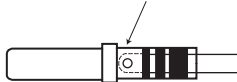

Contact Size	1	Color Bands 2	3	Cannon Part Number	M39029 Military Part Number	Superseded Military Part Number
22D	Orange	Green	Yellow	031-1147-000	M39029/57-354	MS27491-22D
*22M	Orange	Green	Green	031-1122-022	M39029/57-355	MS27491-22M
*22	Orange	Green	Blue	031-1125-022	M39029/57-356	MS27491-22
20	Orange	Green	Violet	031-1124-031	M39029/57-357	MS27491-20
16	Orange	Green	Gray	031-1123-016	M39029/57-358	MS27491-16
12	Orange	Green	White	031-1238-000	M39029/57-359	MS27491-12

\*Inactive for new design.

## Contacts-Socket (Series I & III)

MIL-C-39029/56

KJL/KJA



Contact Size	1	Color Bands 2	3	Cannon Part Number	M39029 Military Part Number	Superseded Military Part Number
22D	Orange	Yellow	Gray	031-1147-007	M39029/56-348	MS27490-22D
20	Orange	Green	Brown	031-1250-012	M39029/56-351	MS27490-20
16	Orange	Green	Red	031-1251-001	M39029/56-352	MS27490-16
12	Orange	Green	Orange	031-1237-000	M39029/56-353	MS27490-12

## Wire Sizes and Diameters

### Wire sizes and diameters

Conact Size	Wire size (AWG)	Finished wire outside dimensions	
		Minimum	Maximum
22D	28, 26, 24, 22	0.030 (0.76)	0.054 (1.37)
22M*	28, 26, 24	0.030 (0.76)	0.050 (1.27)
22*	26, 24, 22	0.034 (0.86)	0.060 (1.52)
20	24, 22, 20	0.040 (1.02)	0.083 (2.11)
16	20, 18, 16	0.065 (1.65)	0.109 (2.77)
12	14, 12	0.097 (2.46)	0.142 (3.61)
8	M17/095-RG-180**	0.135 (3.43)	0.155 (3.94)

\*Inactive for new design.

\*\* MIL-C-17

Connectors shall meet the requirements specified when:

- A full complement of wire of the applicable minimum or maximum insulation diameter is installed.
- Any combinations of wire diameters not exceeding dimensions of (a), above can be used.

Note: Contacts for printed circuit and wire wrap applications are also available. Consult ITT Cannon.

## Backshell - Type E (Straight), Series II only

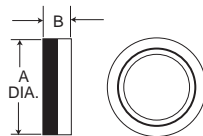

Shell Size		
Series II	A Dia. Max.	B Dia. Max.
8	.580 (14.73)	.328 (8.33)
10	.705 (17.91)	.328 (8.33)
12	.830 (21.08)	.328 (8.33)
14	.955 (24.26)	.328 (8.33)
16	1.080 (27.32)	.328 (8.33)
18	1.205 (30.61)	.328 (8.33)
20	.330 (33.78)	.328 (8.33)
22	1.455 (36.96)	.328 (8.33)
24	1.555 (39.50)	.270 (6.86)

### How To Order

Shell Size	Finishes			
	A	B	C	N
Series II	Cadmium/Nickel-Clear Part Number	Cadmium/Nickel-O.D Part Number	Anodic Non-Cond. Part Number	Electroless Nickel Part Number
8	057-0776-000	057-0862-000	057-0819-000	057-0776-002
10	057-0777-000	057-0863-000	057-0820-000	057-0777-002
12	057-0778-000	057-0864-000	057-0821-000	057-0778-002
14	057-0779-000	057-0846-000	057-0822-000	057-0779-002
16	057-0780-000	057-0847-000	057-0823-000	057-0780-002
18	057-0781-000	057-0848-000	057-0824-000	057-0781-002
20	057-0782-000	057-0849-000	057-0825-000	057-0782-002
22	057-0783-000	057-0850-000	057-0826-000	057-0783-002
24	057-0784-000	057-0851-000	057-0827-000	057-0784-002

## Backshell - Type F (Cable Clamp)

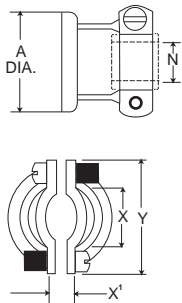

Shell Size						
Series I	Series II	A Max.	N Dia. Max.	X Dia. Min.	X' Dia. Min.	Y Max.
9	8	.508 (14.73)	.135 (3.43)	.234 (5.94)	.187 (4.75)	.829 (21.06)
11	10	.705 (17.91)	.198 (5.03)	.297 (7.54)	.187 (4.75)	.891 (22.63)
13	12	.830 (21.08)	.322 (7.18)	.422 (10.72)	.281 (7.14)	1.016 (25.81)
15	14	.955 (24.26)	.385 (9.78)	.547 (12.89)	.325 (8.26)	1.141 (28.98)
17	16	1.080 (27.43)	.510 (12.95)	.609 (15.47)	.356 (9.04)	1.203 (30.56)
19	18	1.205 (30.61)	.635 (16.13)	.734 (18.64)	.456 (11.58)	1.469 (37.31)
21	20	1.330 (33.78)	.635 (16.13)	.734 (18.64)	.519 (13.18)	1.469 (37.31)
23	22	1.455 (36.96)	.760 (19.30)	.922 (23.42)	.519 (13.18)	1.656 (42.06)
25	24	1.555 (39.50)	.810 (20.57)	.984 (24.99)	.657 (16.69)	1.750 (44.45)

### How To Order (MS Version)

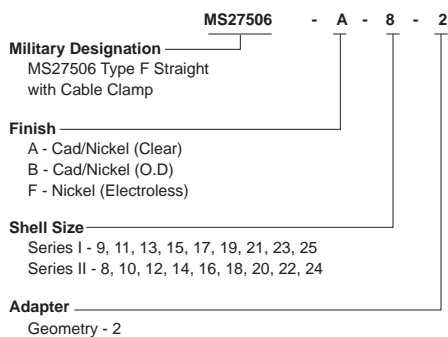

Shell Size		Finishes							
Series I	Series II	MS Part Number	Cannon Part Number	Cannon	A	B	N	F	
					Cannon	MS	Cannon	MS	Cannon
9	8	27506-*8-2	057-3005-***	-012	A	-013	B	-015	F
11	10	27506-*10-2	057-3006-***	-011	A	-012	B	-014	F
13	12	27506-*12-2	057-3007-***	-012	A	-013	B	-015	F
15	14	27506-*14-2	057-3008-***	-010	A	-011	B	-013	F
17	16	27506-*16-2	057-3009-***	-012	A	-013	B	-015	F
19	18	27506-*18-2	057-3010-***	-013	A	-014	B	-016	F
21	20	27506-*20-2	057-3011-***	-011	A	-013	B	-015	F
23	22	27506-*22-2	057-3012-***	-015	A	-016	B	-018	F
25	24	27506-*24-2	057-3013-***	-013	A	-014	B	-017	F

\* MS Finish      \*\*\* Cannon Finish

**Backshell - Type P (Potting Boot)**

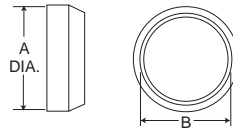

Shell Size		A Dia. Max.	B Dia. Max.
Series I	Series II		
9	8	.598 (15.19)	.434 (11.02)
11	10	.723 (18.36)	.548 (13.92)
13	12	.847 (21.51)	.673 (17.09)
15	14	.969 (24.61)	.798 (20.27)
17	16	1.087 (27.61)	.899 (22.83)
19	18	1.211 (30.76)	1.024 (26.01)
21	20	1.336 (33.93)	1.141 (29.98)
23	22	1.461 (37.11)	1.274 (32.36)
25	24	1.586 (40.28)	1.399 (35.53)

How To Order (MS Version)

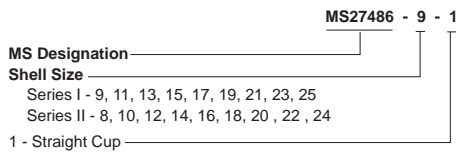

NOTE: When ordering the MS version you must specify both MS numbers for the Potting Boot and the Adapter Ring.

Shell Size		MS27486 Part Number	Cannon Part Number
Series I	Series II		
9	8	27486-**-1	040-0185-000
11	10	27486-**-1	040-0169-000
13	12	27486-**-1	040-0170-000
15	14	27486-**-1	040-0171-000
17	16	27486-**-1	040-0172-000
19	18	27486-**-1	040-0173-000
21	20	27486-**-1	040-0174-000
23	22	27486-**-1	040-0175-000
25	24	27486-**-1	040-0176-000

\*\* Specify applicable Series I or II, shell size.

**Adapter Ring**

How To Order (MS Version)

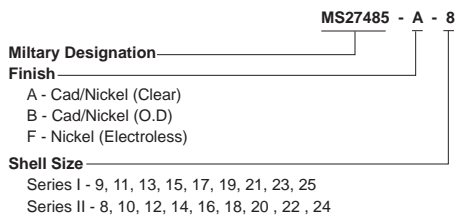

NOTE: When ordering the MS version you must specify both MS numbers for the Potting Boot and the Adapter Ring.

Shell Size		MS27485 Part Number	Cannon Part Number	Finishes							
Series I	Series II			A Cadmium/Nickel-Clear		B Cadmium/Nickel-O.D		N Electroless		F Nickel	
				Cannon	MS	Cannon	MS	Cannon	MS	Cannon	MS
9	8	27485-***	237-0887-***	-000	A	-001	B	-002	F		
11	10	27485-***	237-0874-***	-000	A	-001	B	-002	F		
13	12	27485-***	237-0875-***	-000	A	-001	B	-002	F		
15	14	27485-***	237-0876-***	-000	A	-001	B	-002	F		
17	16	27485-***	237-0877-***	-000	A	-001	B	-002	F		
19	18	27485-***	237-0878-***	-000	A	-001	B	-002	F		
21	20	27485-***	237-0879-***	-000	A	-001	B	-002	F		
23	22	27485-***	237-0880-***	-000	A	-001	B	-003	F		
25	24	27485-***	237-0881-***	-000	A	-001	B	-003	F		

\* MS Finish  
 \*\* Specify applicable Series I or II shell size  
 \*\*\* Cannon Finish

**Wire Sealing Plugs**

Series III Size	Series I & II Size	Part Number		Color Code
		ITT Cannon	MS27488	
22D	22D	225-1013-000	MS27488-22	Black
22M	22M	225-1013-000	MS27488-22	Black
-	22	225-1013-000	MS27488-22	Black
20	20	225-0070-000	MS27488-20	Red
16	16	225-0071-000	MS27488-16	Blue
12	12	225-0072-000	MS27488-12	Yellow

Wire sealing plugs meet MS27488 standards. The plugs are color coded according to size for easy identification. Wire sealing plugs may be ordered separately.

**Tools - Crimp**



M22520/1-01

CBT-530

M22520/2-01

CBT-565

Contact Size	Pin Contact Series I/II/III		Socket Contact Series II		Socket Contact Series I & III	
	Crimp Tool Part Number	Locator or Turret Part Number	Crimp Tool Part Number	Locator or Turret Part Number	Crimp Tool Part Number	Locator or Turret Part Number
22D or 22M	M22520/2-01	M22520/2-09	M22520/2-01	M22520/2-06	M22520/2-01	M22520/2-07
22	M22520/2-01	M22520/2-09	M22520/2-01	M22520/2-06	M22520/2-01	M22520/2-07
20	M22520/1-01	M22520/1-04 OR TH 187	M22520/1-01	M22520/1-04	M22520/1-01	M22520/1-04
16	M22520/1-01	M22520/1-04 OR TH 187	M22520/1-01	M22520/1-04	M22520/1-01	M22520/1-04
12	M22520/1-01	M22520/1-04	M22520/1-01	M22520/1-04	M22520/1-01	M22520/1-04

**Tools - Plastic**



Insertion/Extraction

Contact Size	Cannon Description	Cannon Part Number	M81969 Part Number	Superseded Military Part Number	Insertion Color Tip	Extraction Color Tip
22D	CIET-22D-01	274-7048-000	M81969/14-01	MS27534-22D	Green	White
22M	CIET-22D-01	274-7048-000	M81969/14-01	MS27534-22D	Green	White
20	CIET-20-10	274-7001-000	M81969/14-10	MS27534-20	Red	Orange
16	CIET-16-03	274-7002-000	M81969/14-03	MS27534-216	Blue	White
12	CIET-12-04	274-7003-000	M81969/14-04	MS27534-12	Yellow	White

**Tools - Metal (MS)**



Insertion



Extraction

Contact Size	Insertion			Extraction			
	MS27495 Part Number	ITT CANNON Part Number	Color Band†	MS27495 Part Number	ITT CANNON Part Number	Color Band†	No.2
22D OR 22M*	MS27495 A22M	995-0001-718	Black	MS27495 R22M	995-0001-719	Black	White
22*	MS27495 A22	995-0001-720	Brown	MS27495 R22	995-0001-721	Brown	White
20	MS27495 A20	995-0001-716	Red	MS27495 R20	995-0001-717	Red	White
16	MS27495 A16	995-0001-732	Blue	MS27495 R16	995-0001-731	Blue	White

† Band No. 1 indicates tool size.

Band No. 2 indicates removal tool.

\* Replacement only, not recommended for new design.

## Wire Stripping

Strip insulation from end of wire to be crimped. (See table for proper stripping dimensions.) Do not cut or damage wire strands.

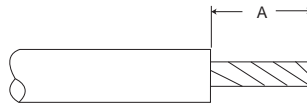

Wire Size	A
22D or 22M*	.125 (3.18)
20	.188 (4.77)
16	.188 (4.77)
12	.188 (4.77)

\* Inactive, not recommended for new design, replacement only.

## Contact Crimping

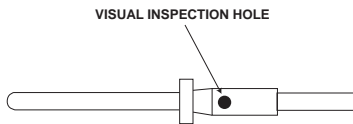

1. Insert stripped wire into contact crimp pot. Wire must be visible thru inspection hole.



2. Using correct crimp tool and locator, cycle the tool once to be sure the indentors are open. Insert contact and wire into locator. Squeeze tool handles firmly and completely to insure a proper crimp. The tool will not release unless the crimp indentors in the tool head have been fully actuated.

3. Release crimped contact and wire from tool. Be certain the wire is visible thru inspection hole in contact.

## Contact Insertion



1. Remove hardware from plug or receptacle and slip over wire bundle in proper order for reassembly.



2. Using proper plastic or metal insertion tool for corresponding contact, position wire in tip of the tool so that the tool tip butts up against the contact shoulder.



3. Press tool against contact shoulder and, with firm and even pressure, insert wired contact and tool tip into center contact cavity. A slight click may be heard as metal retaining tines snap into place behind contact shoulder.



4. Remove tool and pull back lightly on wire to make sure contact is properly seated. Repeat operation with remainder of contacts to be inserted, beginning with the center cavity and working outward in alternating rows.



5. After all contacts are inserted, fill any empty cavities with wire sealing plugs. Reassemble plug or receptacle hardware.

## Contact Extraction



1. Remove hardware from plug or receptacle and slide hardware back along wire bundle.



2. Using plastic or metal extraction tool with proper color code corresponding to contact size, place wire in tool.



3. Insert tool into contact cavity until tool tip bottoms against the contact shoulder, expanding clip retaining tines.



4. Hold wire firmly in tool and extract wired contact and tool. Repeat operation for all contacts to be extracted.



5. Fill any empty wire cavities with wire sealing plugs, and



6. Reassemble plug or receptacle.



# MIL-C-38999 Series I, II, III Connectors

## MIL-C-38999 Specifications

The following excerpts are some of the parameter requirements of the MIL-C-3899 Specification.

Test Description	Paragraph Reference	Requirements																																																																															
Contact Retention	4.7.19	After preloading to 3 pounds maximum, the force shall be applied at a rate of approximately 1 pound per second and maintained at full load for 5-10 seconds. No damage to contacts or insert shall result nor shall the contacts be dislocated from their normal position in the connector more than 0.012 inch under the given load. Failure to meet these requirements shall be cause for rejection.																																																																															
		<table border="1"> <thead> <tr> <th>Contact Size</th> <th>22M</th> <th>22D</th> <th>22</th> <th>20</th> <th>16</th> </tr> </thead> <tbody> <tr> <td>Loads in Pounds <math>\pm</math> 10%</td> <td>10</td> <td>10</td> <td>10</td> <td>15</td> <td>25</td> </tr> </tbody> </table>	Contact Size	22M	22D	22	20	16	Loads in Pounds $\pm$ 10%	10	10	10	15	25																																																																			
Contact Size	22M	22D	22	20	16																																																																												
Loads in Pounds $\pm$ 10%	10	10	10	15	25																																																																												
Coupling Torque	4.7.6	For qualification testing, mating halves shall be coupled and uncoupled, measuring the torques necessary. The torques required to couple and uncouple mating connector halves shall fall within the limits specific as follows:																																																																															
		<table border="1"> <thead> <tr> <th rowspan="2">Shell Size</th> <th colspan="3">Torque lb/in.</th> <th rowspan="2">Shell Size</th> <th colspan="3">Torque lb/in.</th> <th rowspan="2">Shell Size</th> <th colspan="3">Torque lb/in.</th> </tr> <tr> <th>Max.</th> <th>Min.</th> <th></th> <th>Max.</th> <th>Min.</th> <th></th> <th>Max.</th> <th>Min.</th> <th></th> </tr> </thead> <tbody> <tr> <td>8/9</td> <td>8</td> <td>2</td> <td></td> <td>14</td> <td>20</td> <td>4</td> <td></td> <td>18</td> <td>28</td> <td>5</td> <td></td> <td>22</td> <td>36</td> <td>7</td> </tr> <tr> <td>10/11</td> <td>12</td> <td>2</td> <td></td> <td>15</td> <td>20</td> <td>3</td> <td></td> <td>19</td> <td>28</td> <td>3</td> <td></td> <td>23</td> <td>36</td> <td>5</td> </tr> <tr> <td>12</td> <td>16</td> <td>2</td> <td></td> <td>16</td> <td>24</td> <td>4</td> <td></td> <td>20</td> <td>32</td> <td>6</td> <td></td> <td>24</td> <td>36</td> <td>7</td> </tr> <tr> <td>13</td> <td>16</td> <td>2</td> <td></td> <td>17</td> <td>24</td> <td>3</td> <td></td> <td>21</td> <td>32</td> <td>5</td> <td></td> <td>25</td> <td>40</td> <td>5</td> </tr> </tbody> </table>	Shell Size	Torque lb/in.			Shell Size	Torque lb/in.			Shell Size	Torque lb/in.			Max.	Min.		Max.	Min.		Max.	Min.		8/9	8	2		14	20	4		18	28	5		22	36	7	10/11	12	2		15	20	3		19	28	3		23	36	5	12	16	2		16	24	4		20	32	6		24	36	7	13	16	2		17	24	3		21	32	5		25
Shell Size	Torque lb/in.			Shell Size	Torque lb/in.			Shell Size	Torque lb/in.																																																																								
	Max.	Min.			Max.	Min.			Max.	Min.																																																																							
8/9	8	2		14	20	4		18	28	5		22	36	7																																																																			
10/11	12	2		15	20	3		19	28	3		23	36	5																																																																			
12	16	2		16	24	4		20	32	6		24	36	7																																																																			
13	16	2		17	24	3		21	32	5		25	40	5																																																																			
Durability	4.7.7	Connector halves shall be mated and unmated 250 times for Series II with ground fingers and 500 times for Series I and III at a rate not exceeding 300 cycles per hour. The test may be performed by hand or by mechanical means, but the coupling ring shall be operated as in normal service. Failure to complete this test because of mechanical malfunction shall be cause for rejection.																																																																															
Insulation Resistance	4.7.9	An insulation resistance test shall be performed on unmated connectors in accordance with MIL-STD-202, Method 302, Test condition B. Measurement shall be made between three pairs of adjacent contacts and the shell. Failure to meet the minimum requirement of 50,000 megohms for Classes E, P, F, R, and T shall be cause for rejection.																																																																															
Vibration	4.7.22	Wired, mated connectors shall be subjected to the vibration test of MIL-STD-202, Method 214, Test Condition II, except that the duration shall be one hour in each plane. Receptacles shall be mounted on the vibration fixture by normal means. All contacts shall be wired in a series circuit and 100-500 milliamperes of current shall be allowed to flow through the series circuit during vibration. Suitable means shall be employed to monitor the current flow and to indicate any discontinuity of more than 1 microsecond. The wire bundle shall be damped to the nonvibrating points at least 8 inches from the rear of the connector. Current discontinuity of 1 microsecond or more, disengagement of the mated connectors, evidence of cracking, breaking, or loosening of parts shall be cause for rejection.																																																																															
Shock	4.7.23	Wired mated connectors shall be subjected to one shock in each direction in each of three mutually perpendicular axes. The pulse shall be approximate half sine wave of 300g $\pm$ 15% magnitude with a duration of 3 $\pm$ 1 milliseconds. Receptacles shall be mounted on a shock fixture by normal means. All contacts shall be wired in a series circuit and 100-150 ma. of current shall flow through the series circuit during shock. Suitable means shall be employed to monitor the current flow and to indicate any discontinuity of more than 1 microsecond. The wire bundle shall be clamped to fixed points at least 8 inches from the rear of the connector. Current discontinuity of 1 microsecond or more, disengagement of the mated connectors, evidence of cracking, breaking, or loosening of parts shall be cause for rejection.																																																																															
Thermal Shock	4.7.4	Unmated receptacles shall be subject to 10 cycles of thermal shock in the following manner: Step a. The receptacle shall be suspended for 10 + 1 - 0 minutes in the center of a cold water bath with a volume of approximately one cubic foot. No dimension of the bath shall be less than 10 inches. The water temperature shall not exceed 4°C (201°F) Step b. The receptacle shall be suspended for 10 - 1 - 0 minutes in the center of a hot water bath with a volume of approximately one cubic foot. No dimension of the bath shall be less than 10 inches. The water temperature shall be not less than 94°C (201°F). The time of transfer from one bath to the other shall not exceed 5 seconds. At the end of the tenth cycle, the receptacle shall have the excess moisture shaken off and shall then be dried in a forced air oven at 66 $\pm$ 5°C for 15 $\pm$ 1 minutes. Any evidence of damage resulting from this test shall be cause for rejection.																																																																															
Altitude Immersion	4.7.8	Mated connectors shall be placed in a container of water at approximately 20°C and placed in an altitude chamber. All wire ends shall be located within the chamber and exposed to the chamber atmosphere, but not submerged. The exposed wire ends shall not be sealed. A quantity of salt, 5 percent by weight, shall be added to make the water conductive. The chamber pressure shall then be reduced to approximately one inch of mercury and maintained for thirty minutes. The chamber pressure shall then be slowly returned to atmospheric. This shall be considered one cycle. Two additional cycles shall be performed. At the end of the last cycle, while the mated connectors are still submerged, the Insulation Resistance Test (room temperature), and the High Potential Test (sea level voltages) shall be performed upon the same circuits. Failure to meet an insulation resistance minimum of 2,000 megohms or any evidence of dielectric breakdown or -flashover shall be cause for rejection.																																																																															
Solvent Immersion	4.7.29	Unmated connectors shall be immersed fully in the applicable fluid specified below for 20 hours. After removal from the fluid, each connector shall remain for one hour in free air at room temperature. a. Jet fuel JP-4 to MIL-J-5624    b. Aircraft lubricating oil to MIL-L-9236																																																																															
Corrosion	4.7.12	Unmated connectors and individual contact samples shall be subjected to the soft spray of MIL-STD-202, Method 101, Test Condition 8 (tin plated, Class Y receptacles-24 hours). Immediately after exposure, the surfaces of the specimens shall be thoroughly washed in tap water and dried in a circulatory oven at a temperature of 38 $\pm$ 3°C (100°F) for a period of approximately 12 hours. Any exposure of basis metal as a result of this test, shall be cause for rejection.																																																																															
Dynamic Salt Spray	4.7.12.2	(Series I and 11, finish B; Series III, class W). The wired assembled plugs and receptacles shall be mated and unmated 50 cycles at a rate of 300 cycles per hour maximum. The mating and unmating shall be accomplished so that the plug and receptacle are completely separated during each cycle. The connectors shall then be subjected to the salt spray test in accordance with method 1001 of MIL-STD- 1344. The connectors shall be tested for 452 hours mated followed by 48 hours unmated. After the salt spray exposure the remaining number of durability cycles specified in 4.7.7 shall be completed.																																																																															
Temperature Durability	4.7.33	Wired, mated connectors shall be subjected to the indicated ambient temperature for a period of 1,000 hours. <table border="1"> <tbody> <tr> <td>Series I and II (finish A) . . . . .</td> <td>150</td> <td>+3° -0°C (302°F)</td> <td>Series I and II (finish B) . . . . .</td> <td>175</td> <td>+3° -0°C (347°F)</td> </tr> <tr> <td>Series III (class W) . . . . .</td> <td>175</td> <td>+3° -0°C (347°F)</td> <td>All others finishes . . . . .</td> <td>200</td> <td>+3° -0°C (392°F)</td> </tr> </tbody> </table>	Series I and II (finish A) . . . . .	150	+3° -0°C (302°F)	Series I and II (finish B) . . . . .	175	+3° -0°C (347°F)	Series III (class W) . . . . .	175	+3° -0°C (347°F)	All others finishes . . . . .	200	+3° -0°C (392°F)																																																																			
Series I and II (finish A) . . . . .	150	+3° -0°C (302°F)	Series I and II (finish B) . . . . .	175	+3° -0°C (347°F)																																																																												
Series III (class W) . . . . .	175	+3° -0°C (347°F)	All others finishes . . . . .	200	+3° -0°C (392°F)																																																																												