



74LVC126A

LOW VOLTAGE CMOS QUAD BUS BUFFERS (3-STATE) HIGH PERFORMANCE

- 5V TOLERANT INPUTS
- HIGH SPEED: $t_{PD} = 4.8\text{ns}$ (MAX.) at $V_{CC} = 3\text{V}$
- POWER DOWN PROTECTION ON INPUTS AND OUTPUTS
- SYMMETRICAL OUTPUT IMPEDANCE:
 $|I_{OH}| = I_{OL} = 24\text{mA}$ (MIN) at $V_{CC} = 3\text{V}$
- PCI BUS LEVELS GUARANTEED AT 24 mA
- BALANCED PROPAGATION DELAYS:
 $t_{PLH} \cong t_{PHL}$
- OPERATING VOLTAGE RANGE:
 $V_{CC}(\text{OPR}) = 1.65\text{V}$ to 3.6V (1.2V Data Retention)
- PIN AND FUNCTION COMPATIBLE WITH 74 SERIES 126
- LATCH-UP PERFORMANCE EXCEEDS 500mA (JESD 17)
- ESD PERFORMANCE:
HBM > 2000V (MIL STD 883 method 3015);
MM > 200V

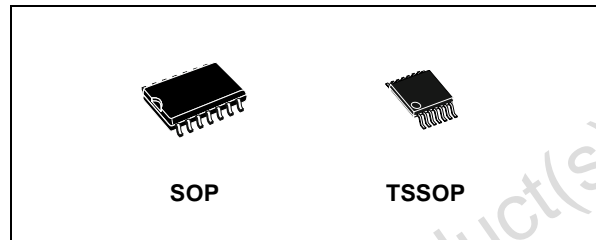

Table 1: Order Codes

PACKAGE	T & R
SOP	74LVC126AMTR
TSSOP	74LVC126ATTR

It can be interfaced to 5V signal environment for inputs in mixed 3.3/5V system.

The device requires the 3-STATE control input G to be set low to place the output go in to the high impedance state.

It has more speed performance at 3.3V than 5V AC/ACT family, combined with a lower power consumption.

All inputs and outputs are equipped with protection circuits against static discharge, giving them ESD immunity and transient excess voltage.

DESCRIPTION

The 74LVC126A is a low voltage CMOS QUAD BUS BUFFER fabricated with sub-micron silicon gate and double-layer metal wiring C²MOS technology. It is ideal for 1.65V to 3.6V V_{CC} operations and low power and low noise applications.

Figure 1: Pin Connection And IEC Logic Symbols

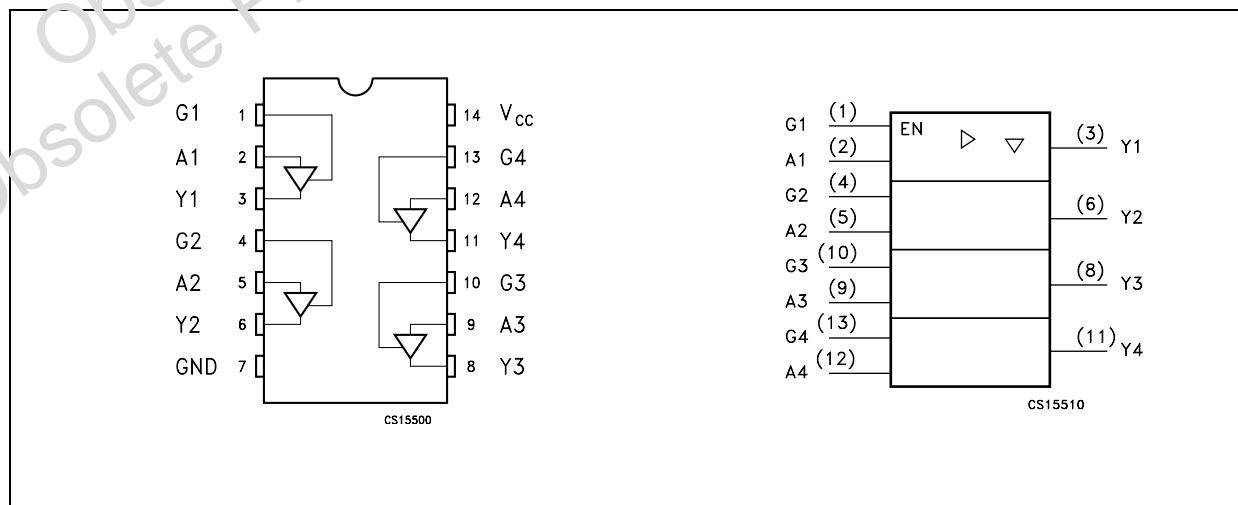

Figure 2: Input And Output Equivalent Circuit

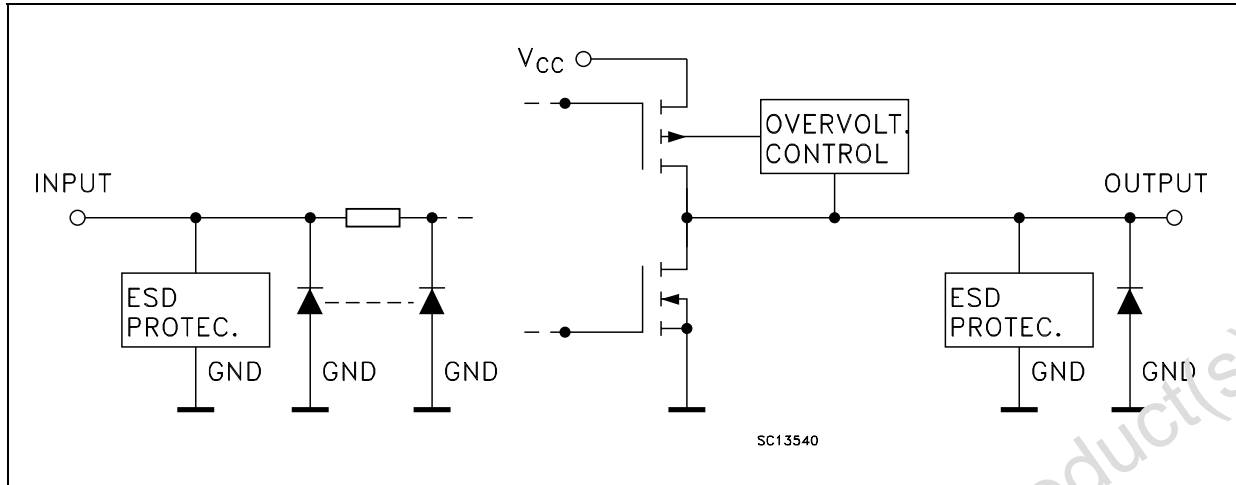

Table 2: Pin Description

PIN N°	SYMBOL	NAME AND FUNCTION
1, 4, 10, 13	G1 to G4	Output Enable Inputs
2, 5, 9, 12	A1 to A4	Data Inputs
3, 6, 8, 11	Y1 to Y4	Data Outputs
7	GND	Ground (0V)
14	V _{CC}	Positive Supply Voltage

Table 3: Truth Table

A	G	Y
X	L	Z
L	H	L
H	H	H

X : Don't care
Z : High Impedance

Table 4: Absolute Maximum Ratings

Symbol	Parameter	Value	Unit
V _{CC}	Supply Voltage	-0.5 to +7.0	V
V _I	DC Input Voltage	-0.5 to +7.0	V
V _O	DC Output Voltage (High Impedance or V _{CC} = 0V)	-0.5 to +7.0	V
V _O	DC Output Voltage (High or Low State) (note 1)	-0.5 to V _{CC} + 0.5	V
I _{IHK}	DC Input Diode Current	- 50	mA
I _{OK}	DC Output Diode Current (note 2)	- 50	mA
I _O	DC Output Current	± 50	mA
I _{CC} or I _{GND}	DC V _{CC} or Ground Current per Supply Pin	± 100	mA
T _{stg}	Storage Temperature	-65 to +150	°C
T _L	Lead Temperature (10 sec)	300	°C

Absolute Maximum Ratings are those values beyond which damage to the device may occur. Functional operation under these conditions is not implied.

- 1) I_O absolute maximum rating must be observed
- 2) V_O < GND

Table 5: Recommended Operating Conditions

Symbol	Parameter	Value	Unit
V_{CC}	Supply Voltage (note 1)	1.65 to 3.6	V
V_I	Input Voltage	0 to 5.5	V
V_O	Output Voltage (High Impedance or $V_{CC} = 0V$)	0 to 5.5	V
V_O	Output Voltage (High or Low State)	0 to V_{CC}	V
I_{OH}, I_{OL}	High or Low Level Output Current ($V_{CC} = 3.0$ to $3.6V$)	± 24	mA
I_{OH}, I_{OL}	High or Low Level Output Current ($V_{CC} = 2.7$ to $3.0V$)	± 12	mA
I_{OH}, I_{OL}	High or Low Level Output Current ($V_{CC} = 2.3$ to $2.7V$)	± 8	mA
I_{OH}, I_{OL}	High or Low Level Output Current ($V_{CC} = 1.65$ to $2.3V$)	± 4	mA
T_{op}	Operating Temperature	-55 to 125	$^{\circ}C$
dt/dv	Input Rise and Fall Time (note 2)	0 to 10	ns/V

1) Truth Table guaranteed: 1.2V to 3.6V

2) V_I from 0.8V to 2V at $V_{CC} = 3.0V$

Table 6: DC Specifications

Symbol	Parameter	Test Condition		Value				Unit
		V_{CC} (V)		-40 to 125 $^{\circ}C$		-55 to 125 $^{\circ}C$		
				min.	Max.	Min.	Max.	
V_{IH}	High Level Input Voltage	1.65 to 1.95		$0.65V_{CC}$		$0.65V_{CC}$		V
		2.3 to 2.7		1.7		1.7		
		2.7 to 3.6		2		2		
V_{IL}	Low Level Input Voltage	1.65 to 1.95			$0.35V_{CC}$		$0.35V_{CC}$	V
		2.3 to 2.7			0.7		0.7	
		2.7 to 3.6			0.8		0.8	
V_{OH}	High Level Output Voltage	1.65 to 3.6	$I_O = -100 \mu A$	$V_{CC} - 0.2$		$V_{CC} - 0.2$		V
		1.65	$I_O = -4 \text{ mA}$	1.2		1.2		
		2.3	$I_O = -8 \text{ mA}$	1.7		1.7		
		2.7	$I_O = -12 \text{ mA}$	2.2		2.2		
		3.0	$I_O = -18 \text{ mA}$	2.4		2.4		
V_{OL}	Low Level Output Voltage	1.65 to 3.6	$I_O = 100 \mu A$		0.2		0.2	V
		1.65	$I_O = 4 \text{ mA}$		0.45		0.45	
		2.3	$I_O = 8 \text{ mA}$		0.7		0.7	
		2.7	$I_O = 12 \text{ mA}$		0.4		0.4	
		3.0	$I_O = 24 \text{ mA}$		0.55		0.55	
I_I	Input Leakage Current	3.6	$V_I = 0$ to $5.5V$		± 5		± 5	μA
I_{off}	Power Off Leakage Current	0	V_I or $V_O = 5.5V$		10		10	μA
I_{OZ}	High Impedance Output Leakage Current	3.6	$V_I = V_{IH}$ or V_{IL} $V_O = 0$ to $5.5V$		± 5		± 5	μA
I_{CC}	Quiescent Supply Current	3.6	$V_I = V_{CC}$ or GND		10		10	μA
			V_I or $V_O = 3.6$ to $5.5V$		± 10		± 10	
ΔI_{CC}	I_{CC} incr. per Input	2.7 to 3.6	$V_{IH} = V_{CC} - 0.6V$		500		500	μA

Table 7: Dynamic Switching Characteristics

Symbol	Parameter	Test Condition		Value			Unit
		V _{CC} (V)		T _A = 25 °C			
				Min.	Typ.	Max.	
V _{OLP}	Dynamic Low Level Quiet Output (note 1)	3.3	C _L = 50pF V _{IL} = 0V, V _{IH} = 3.3V		0.8		V
V _{OLV}					-0.8		

1) Number of output defined as "n". Measured with "n-1" outputs switching from HIGH to LOW or LOW to HIGH. The remaining output is measured in the LOW state.

Table 8: AC Electrical Characteristics

Symbol	Parameter	Test Condition				Value				Unit
		V _{CC} (V)	C _L (pF)	R _L (Ω)	t _s = t _r (ns)	-40 to 85 °C		-55 to 125 °C		
						Min.	Max.	Min.	Max.	
t _{PLH} t _{PHL}	Propagation Delay Time	1.65 to 1.95	30	1000	2.0		9.0		12	ns
		2.3 to 2.7	30	500	2.0		6.3		8.5	
		2.7	50	500	2.5	1.5	5.5		6.5	
		3.0 to 3.6	50	500	2.5	1	4.0		5.8	
t _{pZL} t _{pZH}	Output Enable Time	1.65 to 1.95	30	1000	2.0		10		13	ns
		2.3 to 2.7	30	500	2.0		8.3		10.8	
		2.7	50	500	2.5	1	6.3		7.6	
		3.0 to 3.6	50	500	2.5	1	5.7		6.8	
t _{pLZ} t _{pHZ}	Output Disable Time	1.65 to 1.95	30	1000	2.0		12.6		16.4	ns
		2.3 to 2.7	30	500	2.0		8.7		11.3	
		2.7	50	500	2.5	2	6.7		8.0	
		3.0 to 3.6	50	500	2.5	2	6		7.2	
t _{OSLH} t _{OSHL}	Output To Output Skew Time (note1, 2)	2.7 to 3.3					1		1	ns

1) Skew is defined as the absolute value of the difference between the actual propagation delay for any two outputs of the same device switching in the same direction, either HIGH or LOW (t_{OSLH} = |t_{PLHm} - t_{PLHn}|, t_{OSHL} = |t_{PHLm} - t_{PHLn}|)
 2) Parameter guaranteed by design

Table 9: Capacitive Characteristics

Symbol	Parameter	Test Condition		Value			Unit
		V _{CC} (V)		T _A = 25 °C			
				Min.	Typ.	Max.	
C _{IN}	Input Capacitance				4		pF
C _{PD}	Power Dissipation Capacitance (note 1)	1.8	f _{IN} = 10MHz		28		pF
		2.5			30		
		3.3			34		

1) C_{PD} is defined as the value of the IC's internal equivalent capacitance which is calculated from the operating current consumption without load. (Refer to Test Circuit). Average operating current can be obtained by the following equation. I_{CC(OPR)} = C_{PD} × V_{CC} × f_{IN} + I_{CC}/4 (per circuit)

Figure 3: Test Circuit

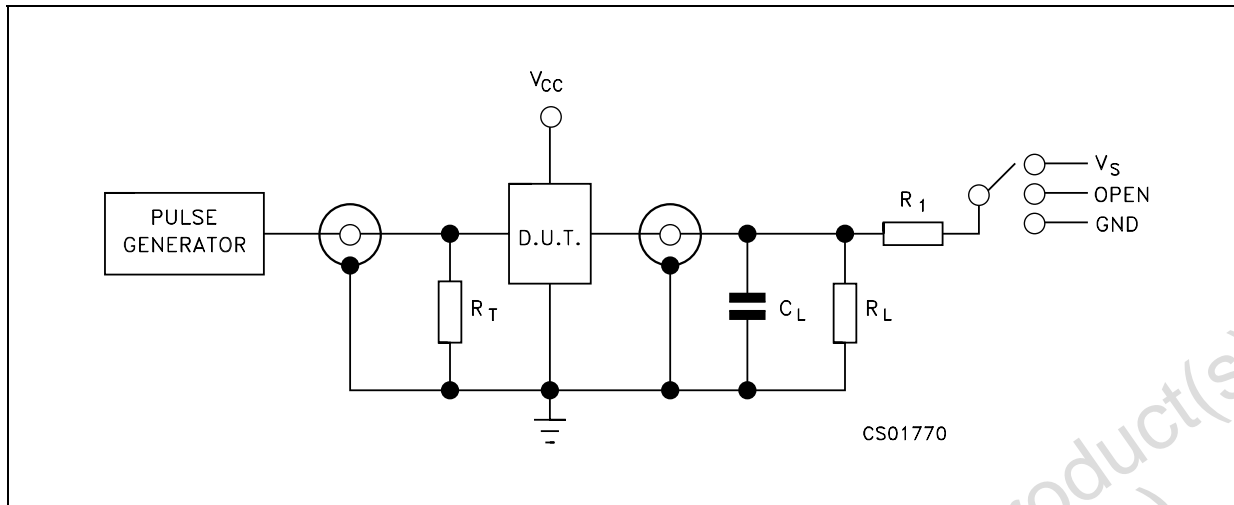

TEST	SWITCH
t_{PLH} , t_{PHL}	Open
t_{PZL} , t_{PLZ} ($V_{CC} = 3.0$ to $3.6V$)	6V
t_{PZL} , t_{PLZ} ($V_{CC} = 2.3$ to $2.7V$ or $V_{CC} = 1.65$ to $1.95V$)	$2V_{CC}$
t_{PZH} , t_{PHZ}	GND

$C_L = 30pF$ or equivalent (includes jig and probe capacitance)

$R_L = R_1 = 500\Omega$ or equivalent

$R_T = Z_{OUT}$ of pulse generator (typically 50Ω)

Table 10: Test Circuit And Waveform Symbol Value

Symbol	V_{CC}			
	1.65 to 1.95V	2.3 to 2.7V	2.7V	3.0 to 3.6V
C_L	30pF	30pF	50pF	50pF
$R_L = R_1$	1000 Ω	500 Ω	500 Ω	500 Ω
V_S	$2 \times V_{CC}$	$2 \times V_{CC}$	6V	6V
V_H	V_{CC}	V_{CC}	2.7V	2.7V
V_M	$V_{CC}/2$	$V_{CC}/2$	1.5V	1.5V
V_{OH}	V_{CC}	V_{CC}	3.0V	3.0V
V_X	$V_{OL} + 0.15V$	$V_{OL} + 0.15V$	$V_{OL} + 0.3V$	$V_{OL} + 0.3V$
V_Y	$V_{OH} - 0.15V$	$V_{OH} - 0.15V$	$V_{OH} - 0.3V$	$V_{OH} - 0.3V$
$t_r = t_f$	<2.0ns	<2.0ns	<2.5ns	<2.5ns

Figure 4: Waveform - Propagation Delays (f=1MHz; 50% duty cycle)

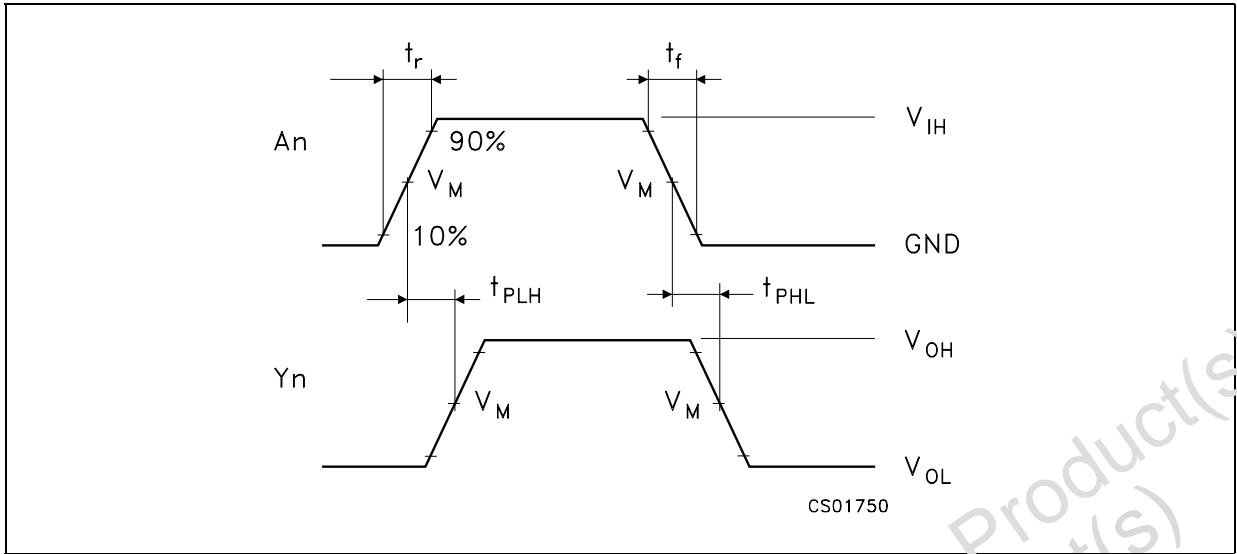
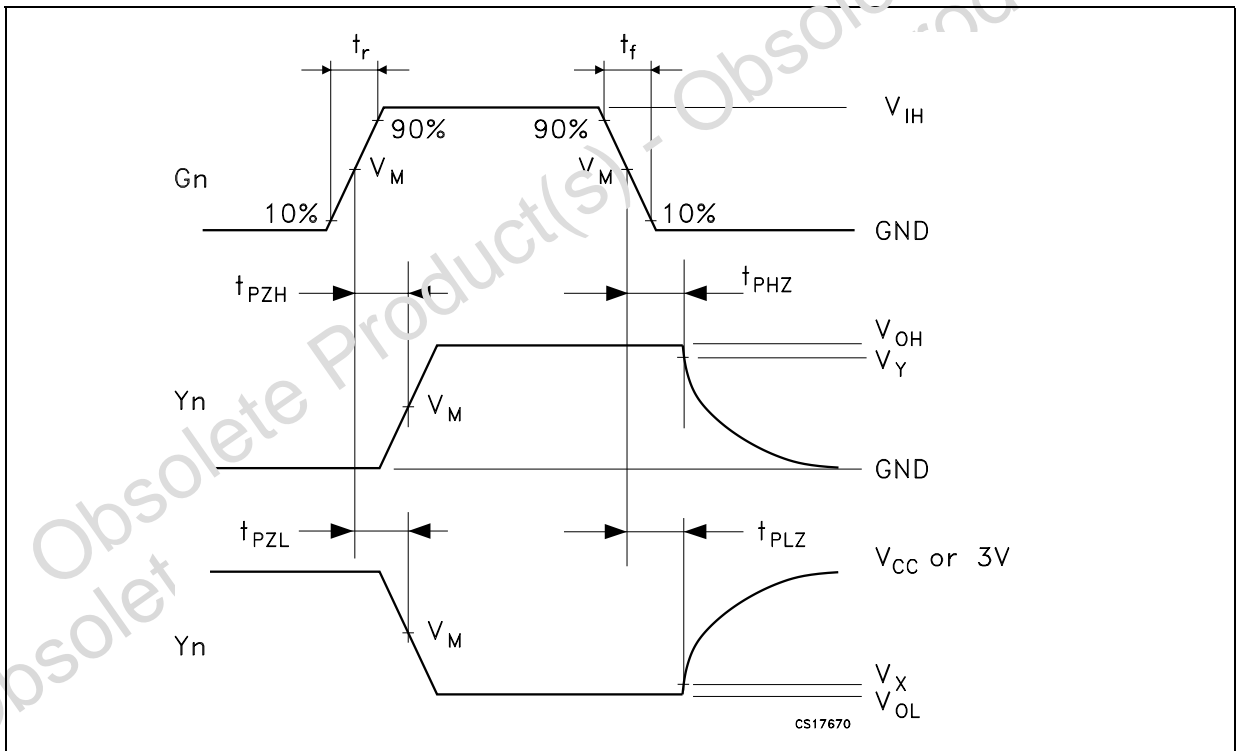
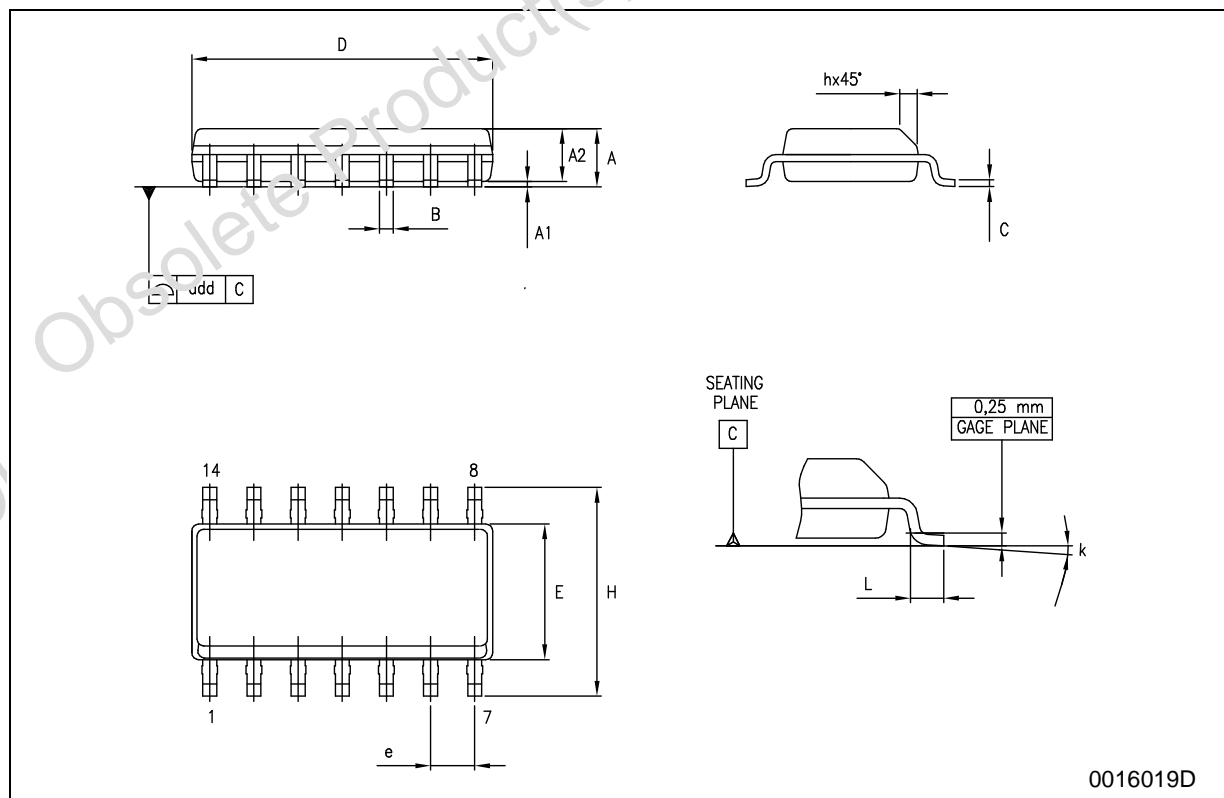

Figure 5: Waveform - Output Enable And Disable Time (f=1MHz; 50% duty cycle)



SO-14 MECHANICAL DATA

DIM.	mm.			inch		
	MIN.	TYP.	MAX.	MIN.	TYP.	MAX.
A	1.35		1.75	0.053		0.069
A1	0.1		0.25	0.004		0.010
A2	1.10		1.65	0.043		0.065
B	0.33		0.51	0.013		0.020
C	0.19		0.25	0.007		0.010
D	8.55		8.75	0.337		0.344
E	3.8		4.0	0.150		0.157
e		1.27			0.050	
H	5.8		6.2	0.228		0.244
h	0.25		0.50	0.010		0.020
L	0.4		1.27	0.016		0.050
k	0°		8°	0°		8°
ddd			0.100			0.004



TSSOP14 MECHANICAL DATA

DIM.	mm.			inch		
	MIN.	TYP	MAX.	MIN.	TYP.	MAX.
A			1.2			0.047
A1	0.05		0.15	0.002	0.004	0.006
A2	0.8	1	1.05	0.031	0.039	0.041
b	0.19		0.30	0.007		0.012
c	0.09		0.20	0.004		0.008
D	4.9	5	5.1	0.193	0.197	0.201
E	6.2	6.4	6.6	0.244	0.252	0.260
E1	4.3	4.4	4.48	0.169	0.173	0.176
e		0.65 BSC			0.0256 BSC	
K	0°		8°	0°		8°
L	0.45	0.60	0.75	0.018	0.024	0.030

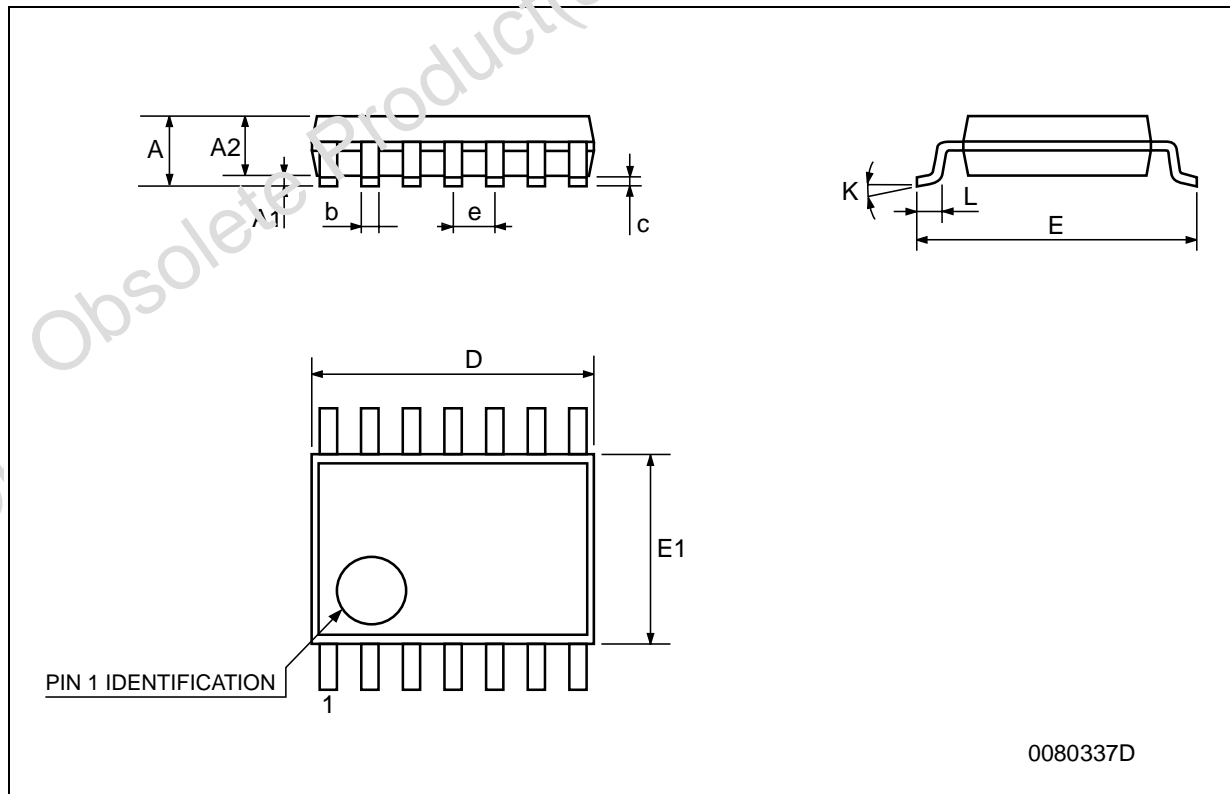

Tape & Reel SO-14 MECHANICAL DATA

DIM.	mm.			inch		
	MIN.	TYP	MAX.	MIN.	TYP.	MAX.
A			330			12.992
C	12.8		13.2	0.504		0.519
D	20.2			0.795		
N	60			2.362		
T			22.4			0.882
Ao	6.4		6.6	0.252		0.260
Bo	9		9.2	0.354		0.362
Ko	2.1		2.3	0.082		0.090
Po	3.9		4.1	0.153		0.161
P	7.9		8.1	0.311		0.319

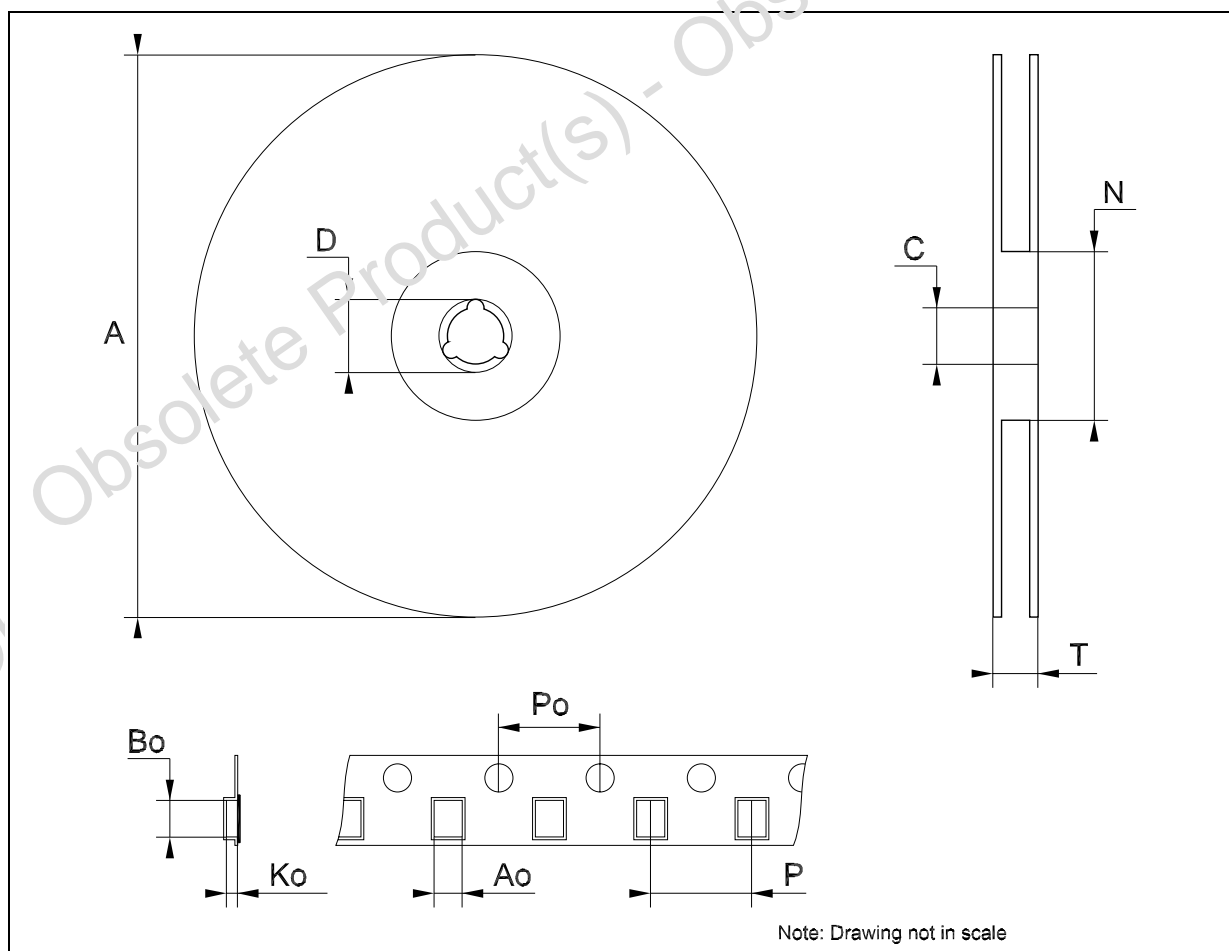

Tape & Reel TSSOP14 MECHANICAL DATA

DIM.	mm.			inch		
	MIN.	TYP	MAX.	MIN.	TYP.	MAX.
A			330			12.992
C	12.8		13.2	0.504		0.519
D	20.2			0.795		
N	60			2.362		
T			22.4			0.882
Ao	6.7		6.9	0.264		0.272
Bo	5.3		5.5	0.209		0.217
Ko	1.6		1.8	0.063		0.071
Po	3.9		4.1	0.153		0.161
P	7.9		8.1	0.311		0.319

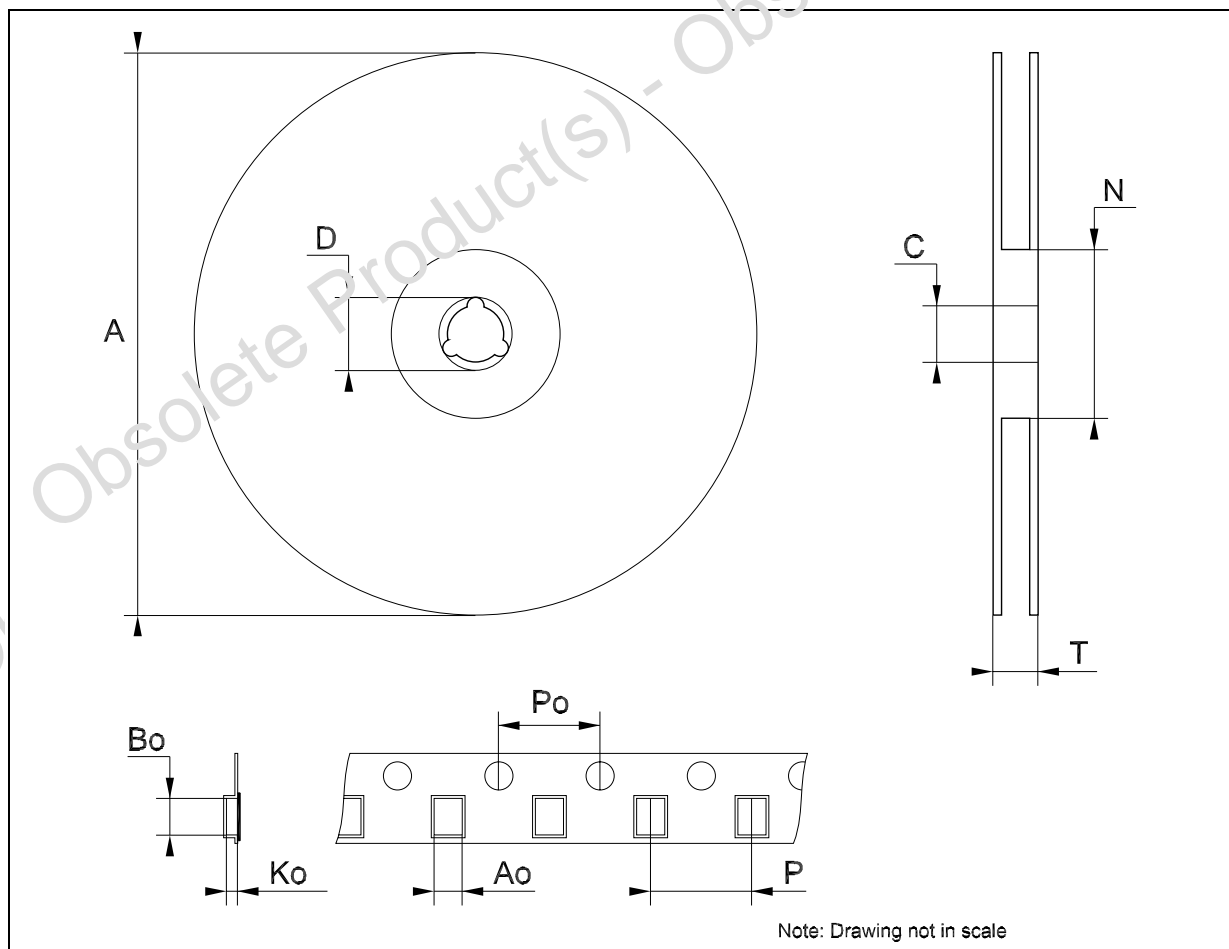

Table 11: Revision History

Date	Revision	Description of Changes
21-May-2004	1	First Release.
26-Jul-2004	2	Ordering Codes Revision - pag. 1.

Obsolete Product(s) - Obsolete Product(s)
Obsolete Product(s) - Obsolete Product(s)

Information furnished is believed to be accurate and reliable. However, STMicroelectronics assumes no responsibility for the consequences of use of such information nor for any infringement of patents or other rights of third parties which may result from its use. No license is granted by implication or otherwise under any patent or patent rights of STMicroelectronics. Specifications mentioned in this publication are subject to change without notice. This publication supersedes and replaces all information previously supplied. STMicroelectronics products are not authorized for use as critical components in life support devices or systems without express written approval of STMicroelectronics.

The ST logo is a registered trademark of STMicroelectronics
All other names are the property of their respective owners

© 2004 STMicroelectronics - All Rights Reserved

STMicroelectronics group of companies

Australia - Belgium - Brazil - Canada - China - Czech Republic - Finland - France - Germany - Hong Kong - India - Israel - Italy - Japan - Malaysia - Malta - Morocco - Singapore - Spain - Sweden - Switzerland - United Kingdom - United States of America

www.st.com