

Marvelmind Indoor Navigation System

Operating manual

v2020_05_21

www.marvelmind.com

Table of contents

1. Executive summary.....	9
1.1 Legend.....	11
2. Basics of the system.....	12
2.1 What's in the box.....	12
2.2 Indoor Navigation System architectures.....	13
2.3 Indoor "GPS" System close-up and internal view.....	15
3. System elements.....	17
3.1 Stationary beacon.....	17
3.2 Mobile beacon a.k.a. "hedgehog".....	18
3.3 Super-Modem.....	19
3.4 Modem.....	25
3.5 Different types of beacons.....	26
3.4.1 Super-Beacon.....	26
3.4.1.1 External microphone extension.....	28
3.4.2 Mini-RX beacon.....	31
3.4.2.1 External microphone extension.....	32
3.4.3 Mini-TX beacon.....	36
3.4.4 Beacon Industrial-TX-Metal.....	37
3.4.5 Beacon Industrial-RX.....	39
3.4.6 Industrial Super-Beacon Metal-25kHz.....	41
3.4.7 HW v4.9 beacon.....	42
3.6 Beacon comparison.....	43
4. Setting up the system (NIA).....	44
4.1 Starter Set Super-NIA-3D.....	44
4.2 Starter Set HW v4.9.....	52
4.3 Starter Set NIA-01-3D.....	60
4.4 Starter Set NIA-SmallDrone.....	68
4.5 Starter Set NIA-02-2D.....	76
4.6 Starter Set Industrial-NIA-01.....	84
5. Setting up the system (IA).....	92
5.1 Starter Set Super-MP-3D.....	92
5.2 Starter Set IA-01-2D.....	100
5.3 Starter Set IA-02-3D.....	108
6. Dashboard menu and parameters.....	116
6.1 Dashboard general view.....	116
6.2 Table of distances.....	117
6.3 Devices list.....	119
6.4 Visualization settings.....	120
6.5 Map Settings.....	121
6.6 Modem/beacon's quick control panel.....	122

6.7	CEILING and MIRRORING buttons on the Dashboard	123
6.8	Detailed settings	124
6.9	Radio frequency band and Carrier frequency.....	140
6.10	Different hedgehog colors in the Dashboard	141
6.11	Different stationary beacons' colors in the Dashboard	142
7.	SW feature/settings descriptions	143
7.1	Licenses.....	143
7.2	Dashboard Monitoring Mode	145
7.3	Geofencing zones	146
7.4	Floors feature (FN0011)	149
7.5	Submap Settings	152
7.6	Axis rotation feature (FN0002).....	153
7.7	Vertical submaps feature (FN0003).....	155
7.8	Handover Zones Setting	158
7.9	Submaps feature (FN0004)	159
7.10	Paired beacons (FN0005).....	165
7.11	Map settings.....	166
7.12	Background color	167
7.13	Hedge color change (FN0006)	169
7.14	Payload streaming (FN0007).....	171
7.15	IMU feature (FN0008).....	172
7.16	IMU axis positioning.....	174
7.17	Player feature (FN0009)	176
7.18	Real-time player feature (FN0010)	179
7.19	CSV format	181
8.	Interfaces	182
8.1	Super-beacon external interface pinout top view	183
8.2	Beacon HW v4.9 external interface 4x4 pinout top view	184
8.3	Modem HW v4.9 external interface pinout top view	185
8.4	Mini-RX internal solderable pinouts (for experienced users only)	186
9.	Advanced system settings and optimization.....	187
9.1	Building big maps in Inverse Architecture (IA).....	188
9.2	TDMA Type 2 - Full-overlapping TDMA	204
9.3	Increasing update rate	206
9.4	Reducing location update latency.....	207
9.5	How to Place Beacons.....	209
9.6	Using the Oscilloscope	210
9.7	Proper Ultrasonic Signal Detection.....	211
9.8	Using hedgehog.log file	212
9.9	System Accuracy Evaluation	213
9.10	Calibration of the accelerometer.....	214

9.11	Settings to obtain correct north direction	216
9.12	Communication of Pixhawk with Marvelmind mobile beacon.....	217
9.13	Sending path to robot	218
9.14	Proper ultrasonic coverage.....	222
9.15	Sensors settings: example for 2D and mobile beacon	224
9.16	Powering beacons	225
10.	Frequently Asked Questions.....	226
11.	Troubleshooting checklist	228
12.	Contacts.....	230

Version changes

V2020_05_21

- Starting up Starter Set Super-MP-3D (IA) described
- Minor fixes and improvements

V2020_05_13

- Reducing update rate latency chapter improved
- Minor fixes and improvements

V2020_05_08

- Building big maps in Inverse Architecture (IA) chapter described
- Minor fixes and improvements

V2020_04_24

- Dashboard Monitoring Mode described
- Super-modem described
- Super-Modem SW update described
- Minor fixes and improvements

V2020_04_09

- Minor fixes and improvements

V2020_04_07

- Background color described
- Height input in Starting up chapters described
- Minor fixes and improvements

V2020_02_27

- Geofencing zones described
- IMU axis positioning for Super-Beacon described
- External microphones soldering scheme for Super-Beacon improved

V2020_02_21

- Minor fixes and improvements

V2020_02_14

- Architectures comparison table added
- Legend chapter improved
- Minor fixes and improvements
- Floorplan Help video added

V2020_01_17

- External microphones connection for Mini-RX and Super-Beacon described
- Minor fixes and improvements

V2019_12_10

- Appendixes chapter improved
- Minor fixes and improvements

V2019_12_03

- Appendixes chapter added (protocols)
- Minor fixes and improvements

V2019_11_18

- Mini-RX solderable pinouts described

- Industrial connectors pinouts improved
- Minor fixes and improvements

V2019_10_31

- Industrial Super-Beacon Metal-25kHz described
- Starting up chapters for every starter set described
- Super-Beacon and Super-Beacon outdoor described
- Improved photos
- Reception diagrams for HW v4.9 improved
- Oscilloscope chapter improved
- Minor fixes and improvements

V2019_07_02

- Troubleshooting improved
- Architectures comparison improved
- Minor fixes and improvements

V2019_06_25

- TDMA modes described
- Stationary beacons' colors described
- Minor fixes and improvements

V2019_06_13

- Delay tuning described
- Update rate tuning described
- Minor fixes and improvements

V2019_06_07

- F.A.Q. and Troubleshooting improved
- Architectures comparison improved
- Receiving and transmitting angles illustrations added (v4.9 chapter and Mini-RX chapter)
- Ceiling and mirroring buttons described

V2019_06_03

- TDMA described

V2019_05_28

- IMU axis positioning fixed
- IA details added
- Troubleshooting improvements
- Minor fixes and improvements

V2019_05_16

- Introduction of the Legend
- Added missing video on page 34
- Minor fixes and improvements

V2019_04_30

- DFU programming described
- Magnetic reset for Industrial beacons and DFU programming described
- Minor fixes

V2019_04_04

- Starting up the system description for different Starter Sets (NIA, Industrial NIA and IA)
- Sending path to robot described

V2019_03_18

- New names for beacons: DSP => Mini-RX, Mini-beacon => Mini-TX, Beacon-TX-25-IMU-IP67-RS485 => Industrial-TX, Beacon-RX-IMU-IP67-RS485 => Industrial-RX
- Starting up the system description for different Starter Sets

V2019_02_05

- Licenses described
- Minor fixes and improvements

V2019_01_29

- Mini-RX Inverse SW flashing described
- Added new types of beacons
- Minor fixes and improvements

V2019_01_12

- Mini-RX beacon and Mini-TX described
- IMU axis described
- Minor fixes and improvements

V2018_12_02

- Major new feature – support for 250 beacons (mobile + stationary combined) and 250 submaps per modem
- New feature: user must setup handover zones between submaps to guarantee handover quality for complex maps with multi-floor and similar
- New feature: default wireless connection is setting is now 153kbps (used to be 38kbps). Radio profile 153kbps provides radio coverage range nearly as much as 38kbps and update rate nearly as high 500kbps, i.e. it is a middle of 38kbps and 500kbps, combining the best of both
- Correction: USB streaming in power save mode improved
- Correction: Zero IMU button in the Dashboard is improved, while button Reset IMU is removed completely
- Correction: ultrasound TX is not reset to 31kHz when Default button is pressed. Now, several types of ultrasonic frequencies supported, so 31kHz is not anymore default ultrasonic frequency for all beacons
- Improved: both energy saving and tracking quality with Power Saving mode enabled
- Improved: only beacons with selected tick in the Dashboard lower menu will be accepted to the network – not any addresses. This improves predictability of the network, when there many beacons that may not belong to the network. Their attempts to join the network will be blocked
- Improved: now, submaps support up to 4 beacons only. More than that – build another submap. Up to 250 beacons (mobile + stationary combined) and up to 250 submaps are supported per beacon
- Bug fix: improved map building with active hedgehog
- Bug fix: duplicated address might work incorrectly in some cases

V2018_11_08

- Real-time player feature described

V2018_08_30

- New SW features described
- New Dashboard view described

V2018_08_03

- Calibration of accelerometer described
- F.A.Q. updated
- Troubleshooting guide described
- Refreshed links

- Player feature described
- IMU feature described
- Minor fixes

V2017_12_29

- SW features paragraph updates
- General updates
- Sending path to robot
- Radio frequency band switch in latest Dashboard version
- Sending path to robot
- Paired beacons feature described
- Submap feature help video
- Different hedgehog colors in the Dashboard
- FAQ updates

V2017_11_01

- Added Sensors settings
- Added Dashboard features
- FAQ
- Fresh Dashboard screenshots
- General updates

V2017_09_08

- Added estimation of accuracy of distances measurement
- Added Raw inertial sensors data
- Added Communication of Pixhawk with Marvelmind mobile beacon
- Added Optimal settings for stationary beacons in small and big rooms
- Added Optimal settings for noisy environment

1. Executive summary

Marvelmind Indoor Navigation System is an off-the-shelf indoor navigation system, designed to provide precise ($\pm 2\text{cm}$) location data to autonomous robots, vehicles (AGV), and copters. It can also be used to track moving objects via mobile beacons attached to them. Other applications include, for example, forklifts, virtual reality (VR) systems, helmets for construction workers or miners, etc.

The navigation system consists of a network of stationary ultrasonic beacons interconnected via radio interface in a license-free band, one or more mobile beacons installed on objects to be tracked and modem providing gateway to the system from PC or other computers.

Mobile beacon's location is calculated based on a propagation delay of an ultrasonic pulses (Time-Of-Flight or TOF) between stationary and mobile beacons using trilateration algorithm.

The system can build the map of stationary beacons automatically (For Non-Inverse Architecture). In simple cases, no additional manual data input or any manual distance measurements are required. This map formed once can be frozen and stored in modem's memory and the system becomes fully active within 7 to 10 seconds after the modem is powered.



Fig. 1: Example of starter set based on Super-beacons

Minimum configuration requirements (Non-Inverse Architecture) to ensure optimal performance of the Marvelmind Indoor Navigation System:





- For 3D (X, Y, Z) tracking: an unobstructed line of sight (hearing) between a mobile beacon and 3 or more stationary beacons within 30 meters
- For 2D (X, Y) tracking - an unobstructed line of sight (hearing) between a mobile beacon and 2 or more stationary beacons within 30 meters

Key capabilities:

Parameter	Technical Specifications
Distance between beacons	<ul style="list-style-type: none"> - Reaches up to 50 meters in lab conditions (Mini-RX or Super-Beacon to HW v4.9 with RX4 only) - Recommended distance is 30 meters (Transducer4 on the first beacon is looking straight at the Transducer4 on the second beacon, other transducers are switched off)
Coverage area	<ul style="list-style-type: none"> - Reaches up to 1000m² with the Starter Set configurations - Coverage for larger territories is provided using submap – like cells in cellular networks
Location precision	<ul style="list-style-type: none"> - Absolute: 1–3% of the distance to the beacons - Differential precision: ±2cm
Location update rate	<ul style="list-style-type: none"> - 1/20Hz to 25Hz (Ultrasonic based only) - 100Hz with ultrasonic + IMU fusion enabled - Can be set manually via Dashboard software - Depends on the distance between mobile and stationary beacons (shorter distance—higher update rate) - Depends on the number of mobile beacons (Non-Inverse Architecture; for Inverse Architecture no such dependency) - Depends on the radio profile (500kbps vs. 38kbps) - Slightly depends on the number of stationary beacons—dependence is not the same as for mobile beacons
Power supply	Internal: 1000mAh LiPo battery (HW v4.9) <ul style="list-style-type: none"> - Battery lifetime: from 2 days to several months depending on the mode of operations *For other types of beacons look to the comparison table
	External: micro USB – recommended for permanent use
Weight	Mobile beacon (HW v4.9) from the starter set: <ul style="list-style-type: none"> - 59 grams (including 1000mAh battery, HW v4.9 housing and 50mm antenna) - 27 grams (HW v4.9, bare board w/o battery) *For other types of beacons look to the comparison table
Beacon size	Size: 55x55x33mm (with 50mm antenna: 55x55x65mm) (HW v4.9) *For other types of beacons look to the comparison table

1.1 Legend

Legend chapter contains small icons and signs to highlight some key points of the text.

-  - Important
-  - For experienced users
-  - Demo or Help video
-  - Useful link

2. Basics of the system

2.1 What's in the box

2.1.1 [Starter Set Super-NIA-3D](#):

- 5 x Super-beacons
- 1 x Modem/Router



2.1.2 [Mini-RX Starter Set](#):

- 4 x Mini-RX beacons
- 1 x Mobile beacon (HW v4.9) + IMU (aka "hedgehog")
- 1 x Modem/Router



*This is just an example of two starter sets.
More options you can see on our site: [Products](#)

2.2 Indoor Navigation System architectures

Marvelmind Indoor Navigation System provides high-precision ($\pm 2\text{cm}$) indoor coordinates for autonomous robots and systems ("indoor GPS"). A brief description of the key elements of the system is given on the scheme below.



IA and NIA SW differs

For IA you should use stationary beacons with **different frequencies**

Below you can see 2 types of architectures: Non-Inverse (NIA) and Inverse (IA):

Non-Inverse Architecture

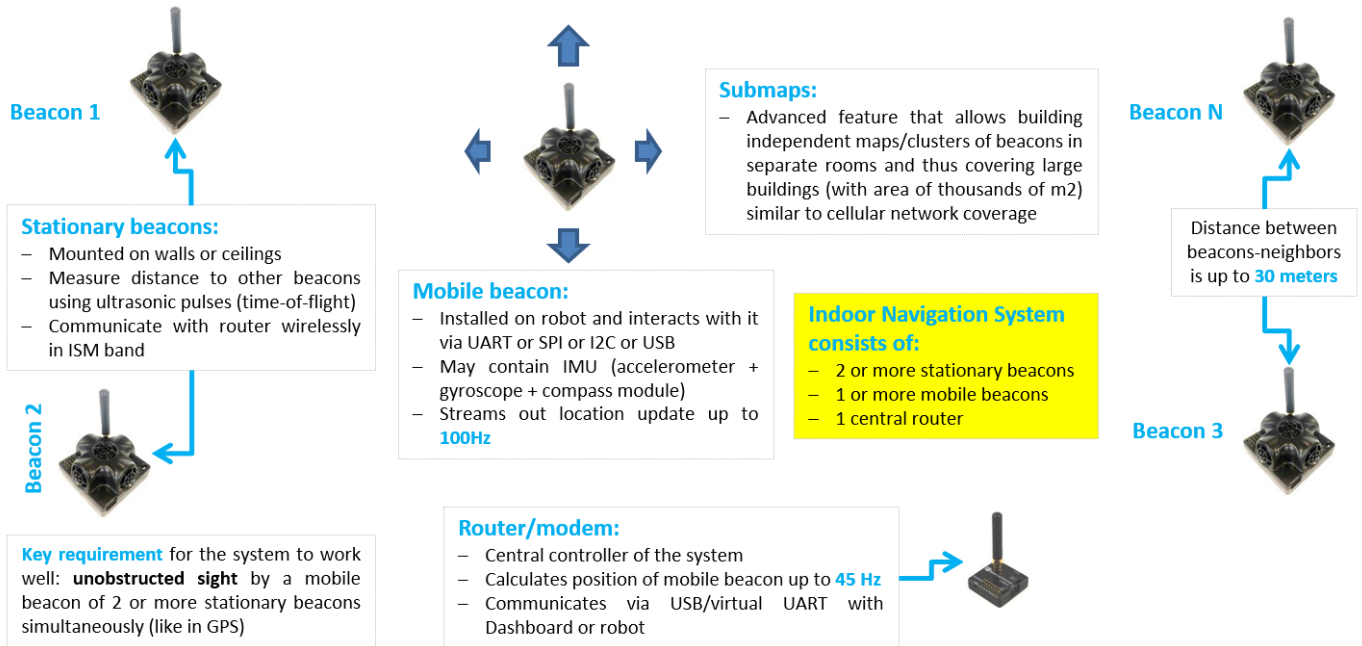

Inverse Architecture

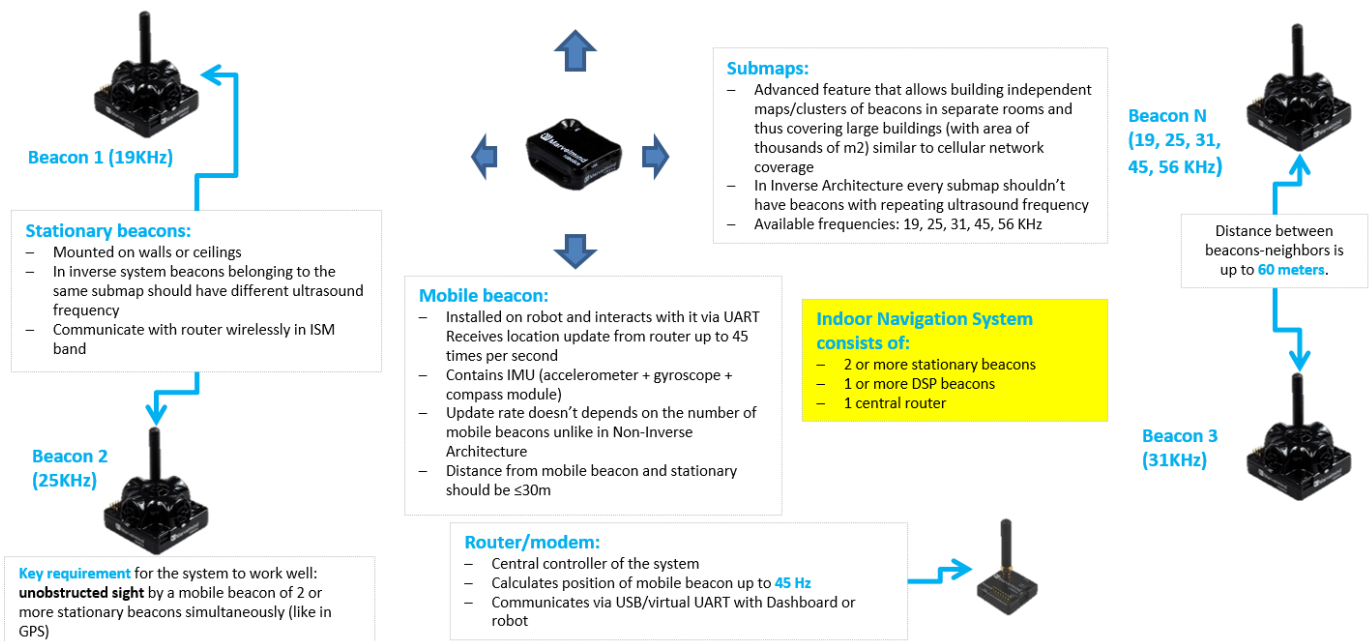

Architecture comparison

	Non-Inverse Architecture (NIA)	Inverse Architecture (IA)
Typical use cases	1-4 autonomous robots/drones. Supported up to 250 beacons When mobile beacon shall be installed on a noisy vehicle, but stationary beacons are in quieter places	Many mobile users (people, robots, VR). Supported up to 250 beacons When mobile beacons are in quieter places
Not recommended	In applications, where emitting ultrasound of mobile beacon is undesirable	For drones, because mobile beacon is receiving ultrasound. The range may be limited to just 2-5m. Special HW solutions and future SW releases will allow to overcome the limitation
Precision	±2cm or better: https://www.youtube.com/watch?v=YAU-WXz26YY	±2cm or better: https://www.youtube.com/watch?v=OXetXiDyAZI
Location update rate	Directly depends on the number of mobile beacons (n) as 1/n –TDMA approach Slightly depends on the radio protocol, if low speed profile (38kbps, etc.) Depends on the sizes of submaps. Larger submap – lower update rate IMU fusion is HW and SW supported	Does not directly depend on the number of mobile beacons Slightly depends on the radio protocol (the same as NIA) Depends on the sizes of submaps (the same as NIA) IMU fusion is HW-supported. SW support is coming
Ultrasonic range	Up to 30m in real life and up to 50m in lab conditions within a submap, i.e. stationary beacons shall be placed every 30m or closer Can cover as large territory as you wish using submaps	
Map building	Can build a submap automatically, if HW v4.9 beacons are used. Mini-beacons cannot build the map, because they are TX-only	Manual entry of stationary beacons' location or distances between them is required for Beacons HW v4.9, because they work on different ultrasonic frequencies Super-beacons v6.0 allow automatic building of submaps (like in in NIA)

2.3 Indoor “GPS” System close-up and internal view

Here, you can see how system elements look like

- Super-beacon



- HW v4.9 modem (without housing)



- Mini-RX beacon



- Mini-TX



- HW v4.9 beacon with Mini-TX size comparison



- Beacon Industrial-RX



- Beacon Industrial-Super



3. System elements

3.1 Stationary beacon

- Usually, mounted on the walls or ceilings above the robot with ultrasonic sensors facing down—to provide the most robust unobstructed ultrasonic signal coverage to the robot. However, for automatic landing and indoor navigation of copters, for example, it is recommended to install mobile beacon horizontally on the belly of the copter so that the beacon would be looking downwards
- The position and orientation of the beacons should be chosen in a way that provides maximum ultrasonic signal coverage. System efficacy strongly depends on the quality of ultrasonic signal received by stationary beacons
- Stationary beacons emit and receive ultrasound during the map configuration period. Once the map is formed and frozen, they only work as the receivers
- Stationary beacons have no exterior differences with regard to mobile beacons
- Inertial measurement unit (IMU) is not installed on the stationary beacons
- The mobile and stationary beacons can be easily interchanged during configuration in the Dashboard
- There are 433MHz and 868/915MHz versions available. A proprietary radio protocol is used for communication and synchronization. Other ISM bands are available upon request as well
- Stationary beacon can be equipped with full-size 165mm antenna (for 433 MHz), which provides more robust radio connection between modem and beacons (for HW v4.9)



Fig.1: Super-beacon as an example

3.2 Mobile beacon a.k.a. “hedgehog”

- The mobile and stationary beacons can be easily interchanged by selecting in the Dashboard
- The mobile beacons designed to be placed on a robotic vehicle, copter/drone, AGV, or helmet to trace its location. Formally speaking, location of the mobile beacon is traced—not the robot itself. Since the sizes and the location of the central point of the mobile beacon and the robot are different, the difference taken into account in the robot’s software (SW)
- It is recommended to place the mobile beacon horizontally to provide optimal ultrasonic coverage in the upper hemisphere
- Its sensors must not be covered with anything that can reduce the strength of ultrasonic signal. For example, the system won’t normally work, if one puts the mobile beacon in a plastic box
- The beacon’s coordinates are updated according to the rate set on the Dashboard
- The system may contain one or several mobile beacons. Current implementation relies on a time-division multiple access approach. Thus, if two mobile beacons are activated, they share the same system bandwidth. It means that, if the 16 Hz update rate is selected in the Dashboard and there are 2 mobile beacons in the system, each beacon’s location will be updated with the rate of $16\text{Hz}/2 \sim 8\text{Hz}$. If there are 3 mobile beacons $\Rightarrow 16\text{Hz}/3 \sim 5\text{Hz}$, etc. For 4 and more mobile beacons we recommend using Inverse Architecture. See more in [Architectures comparison](#)
- Location data is obtained either from the “hedgehog” via USB (virtual UART), UART, SPI, or from the modem/router via USB (virtual UART). More information on interfaces can be found [here](#) (Mini-RX and Mini-TX beacons do not have pinouts, only over micro-USB)
- Data from the beacon sent in a streaming format identical to that of GPS (NMEA 0183)
- There are 433MHz and 868/915MHz (868/915MHz only for Mini-RX and Super-Beacon) versions available. Proprietary radio protocol is used for communication and synchronization
- The “hedgehog” has been successfully integrated with Windows PC, Linux machines, Raspberry Pi, Arduino boards, Intel boards, etc.



Fig. 1: Super-beacon as an example



3.3 Super-Modem

Super-Modem is a superior version of the Modem HW v4.9 with advanced capabilities:

- Super-modem supports all the basic features of HW v4.9 Modem and can be connected over USB to the Dashboard for system tuning and control (Do not forget to power Super-Modem via Power connector)
- UDP streaming over Wi-Fi is supported. In the future remote control of the modem and the whole system via TCP-IP will be supported too
- Bluetooth (HW enabled, but not yet supported in SW)
- >1000x more RAM and >1000x Flash memory than Modem HW v4.9
- Full-size bendable antenna by default
- Higher ingress protection - up to IP67 (optional)
- Super-Modem's HW supports Super-Modem and Super-Super-Modem functionality for Multi-Modem architecture: https://marvelmind.com/pics/marvelmind_presentation.pdf
- Designed for outdoor and industrial applications
- External bendable antennas with SMA connector for extended radio range included
- Currently, supports license-free 915MHz ISM band (for example, US, Japan, Korea) and license-free SRD band 868MHz (EU, Russia). Future 433MHz HW variants may come in some months, but no firm schedule yet. You can place orders for 433MHz. When sufficient amount is collected, we will produce the 433MHz version as well
- Supports all types of beacons working in the 915MHz band (among them: Super-Beacons, all Industrial beacons, Mini-RX, Beacons HW v4.9, Helmets, Badges, Jackets, Watches, etc.)
- Two IP67 external connectors included (similar to Industrial beacons):



Fig. 1: Super-Modem

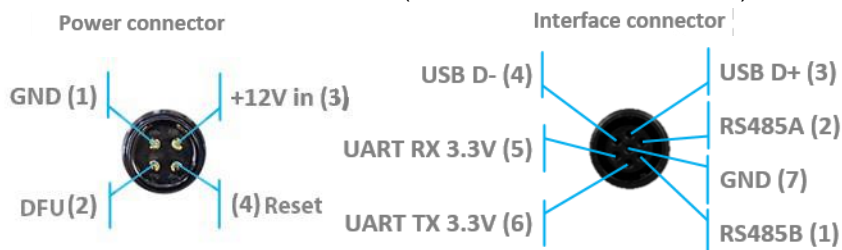

- Exactly the same mounting holes as for Industrial beacons
- No battery inside – external power supply (+6..17V) required (for example, <https://marvelmind.com/product/converter-220v-12v-ip67/>). External battery is not practical for long-term due to relatively high and constant power consumption of 1.5-2W
- For optional IP67 version – extended working temperature range: -40C...+50C (provided by design – not tested, not certified)
- Embedded reset switch and DFU switch – magnetic control or external pins on IP67

- Supports both IA and NIA. Can be easily switched between the modes in the Dashboard
- Radio range to beacons – up to a few hundred meters in the open space area. Wi-Fi – a few tens of meters in the open space



Fig.2: Super-Modem's contents of delivery

Super-Modem's SW update

Marvelmind Super-Modem software consists of two parts:

- Low level firmware
- High level software for integrated Raspberry Pi single-board computer

Low level firmware is placed in general software package with all Marvelmind software in 'Super-Modem' folder. This firmware can be updated via dashboard (hex file) or via DFU (dfu file) like other firmware in the package. Please refer to Operating Manual for details of updating software via dashboard or dfu.

High level software is located on micro-SD card inserted in the Raspberry Pi single-board computer inside Super-Modem. To update this software, you should write on this micro-SD card the image of micro-SD card with updated software. You can download the image on downloads page (<https://marvelmind.com/download/>). The image is placed in archive separately from general software package because its size is pretty large (archive is about 1.5...2 GB).

Micro-SD card location

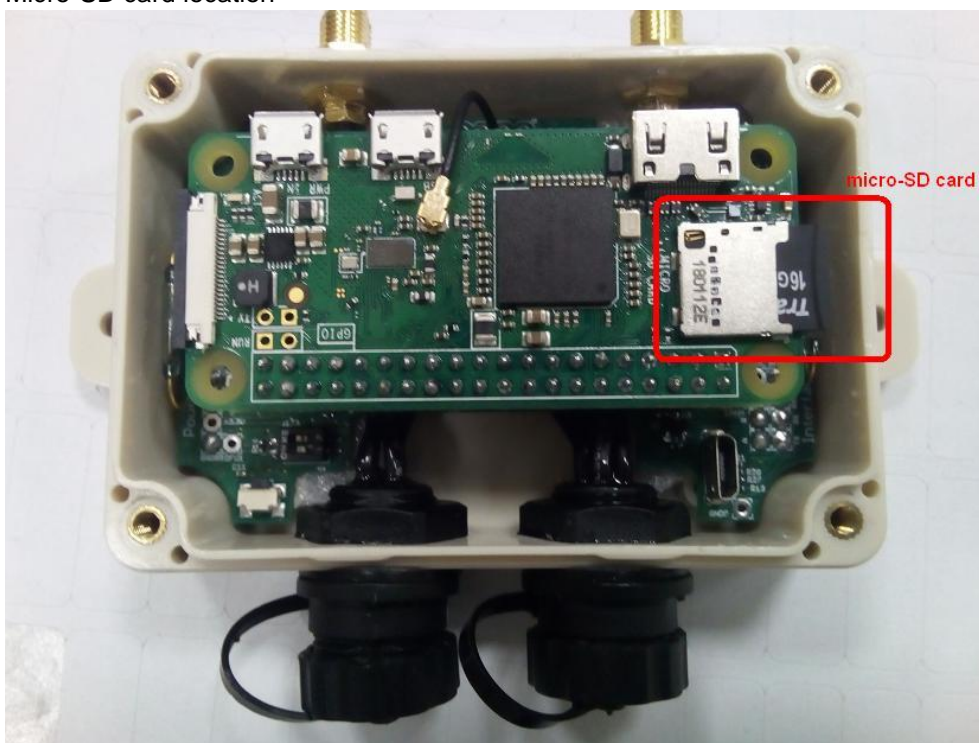

How to update SW:

- Open Super-Modem enclosure
- Eject the micro-SD card (Super-Modem should not be powered at this time)
- Insert micro-SD card into any MS Windows computer via card reader
- Download and unpack the archive with image of updated software

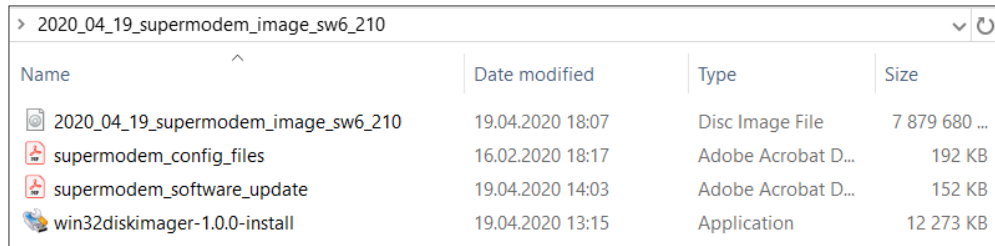

Name	Date modified	Type	Size
2020_04_19_supermodem_image_sw6_210	19.04.2020 18:07	Disc Image File	7 879 680 ...
supermodem_config_files	16.02.2020 18:17	Adobe Acrobat D...	192 KB
supermodem_software_update	19.04.2020 14:03	Adobe Acrobat D...	152 KB
win32diskimager-1.0.0-install	19.04.2020 13:15	Application	12 273 KB

- Install and run Win32 disk imager program (supplied in the archive with image)
- Open the image file and write to the micro-SD card (see screenshot below)

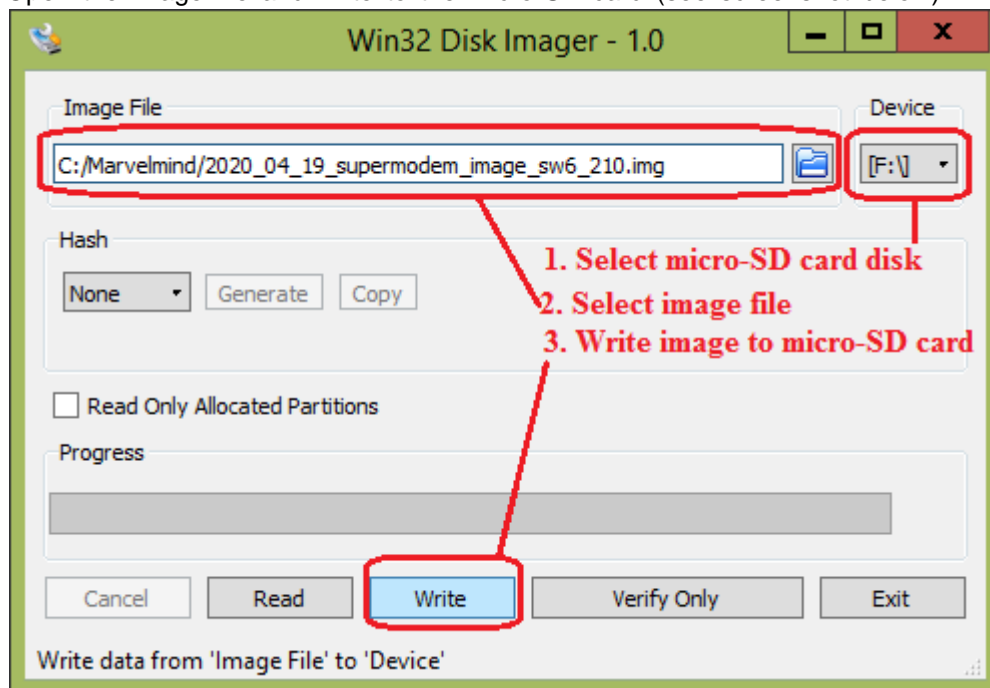

- Eject micro-SD card from computer and insert back into Super-Modem
- Close Super-Modem enclosure

Super-Modem's configuration

Marvelmind Super-Modem contains Raspberry Pi single-board computer with corresponding software. Some settings can be modified via configuration files on the micro-SD card inserted in the Super-Modem.

To modify these files, you need to:

- Open Super-Modem enclosure
- Eject the micro-SD card (Super-Modem should not be powered at this time),
- Insert micro-SD card into any computer with Linux
- Open and modify certain configuration files on the micro-SD card (see below)
- Eject micro-SD card from computer and insert back into Super-Modem
- Close Super-Modem enclosure

Micro-SD card location



When you insert it into computer with Linux, required files are usually located by following path:

/media/<user name>/rootfs/home/pi/supermodem:

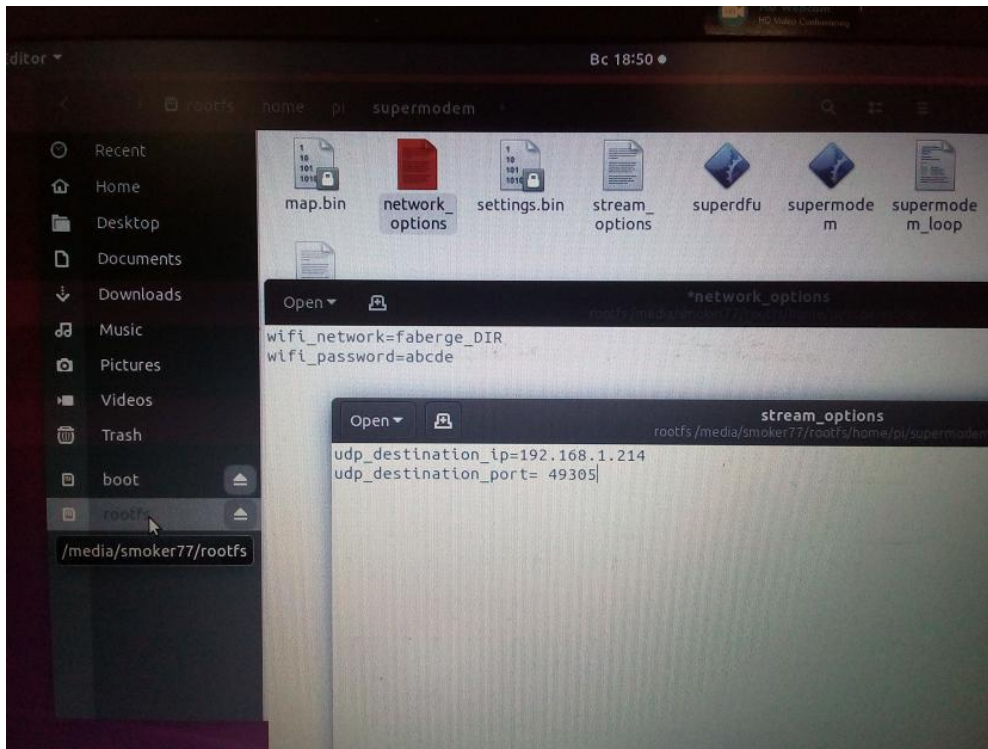

Following settings are available:

In file “network_options”:

- **wifi_network** – name (SSID) of WiFi network to connect
- **wifi_password** – password (PSK) for this network

In file “stream_options”:

- **udp_destination_ip** – IP address in local network where Super-Modem will stream data
- **udp_destination_port** – UDP port where Super-Modem will stream data

3.4 Modem

- Modem is the central controller of the system. It must always be powered when the Navigation System is working. It is recommended to use an active USB hub for that purpose or even a regular cellular phone USB power supply. A USB power bank can also be used
- The modem is also used to set up the system, monitor it, and interact with the Dashboard
- It can be placed anywhere within radio coverage for permanent radio connection with all beacons—usually in the radius of up to 100 meters with antennas from the Starter Set
- Radio coverage further extended to a few hundred meters by using a lower bitrate of 38kbps and full-size (165mm for a 433MHz band) antennas, which have been tested to provide up to 400m in ideal conditions
- There are 433MHz and 915MHz versions available
- A proprietary radio protocol used for communication and synchronization between modem and beacons



Fig. 1: HW v4.9 Modem

3.5 Different types of beacons

3.4.1 Super-Beacon

The Super-Beacon is a dual-use beacon – it can both receive and transmit ultrasonic pulses.

The Super-Beacon Beacon can be used in both the Non-Inverse Architecture (NIA) and the Inverse Architecture (IA): [Architecture comparison](#).

Supports license-free 915MHz ISM band (US) and license-free SRD band 868MHz (EU). Support of the 433MHz ISM band (EU) comes with a larger order.

Key features:

- The Super-Beacon has a separate receiving part with a single wide-beam microphone and sharp DSP filters (like Mini-RX or Industrial-RX has). Thus, it is more sensitive, than Beacon HW v4.9, more resistant to external noise, and easier to setup, because you don't have to care about turning on and off ultrasonic sensors in order to optimize coverage vs. sensitivity
- The Super-Beacon can receive any ultrasonic frequency from the bands: 19kHz, 25kHz, 31kHz, 37kHz, 45kHz. The filter can be simply selected in the Dashboard. At the same time, the ultrasonic frequency of Beacon HW v4.9 is HW-defined by ultrasonic sensors and can't be changed
- The Super-Beacon can receive several ultrasonic frequencies at once. That is used in the Inverse Architecture. See the [comparison](#)
- The Super-Beacon has several-times improved battery lifetime in TX mode as compared with Beacon HW v4.9
- The Super-Beacon can work with regular Beacons HW v4.9 and Mini-RX and Industrial-RX in any combination as a part of a Starter Set or as a part of navigation systems. In all cases, beacons shall use the same radio band



[Super-Beacon also has outdoor \(IP54\) version](#), which is protected from dust and water



Demo video: <https://www.youtube.com/watch?v=cIA2Gc5KaQI>



Figure 1 Outdoor version (IP54)

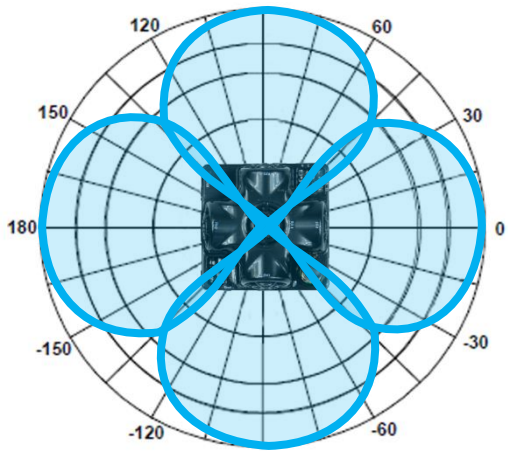

Figure 2 Transmitting diagram (with sensors)

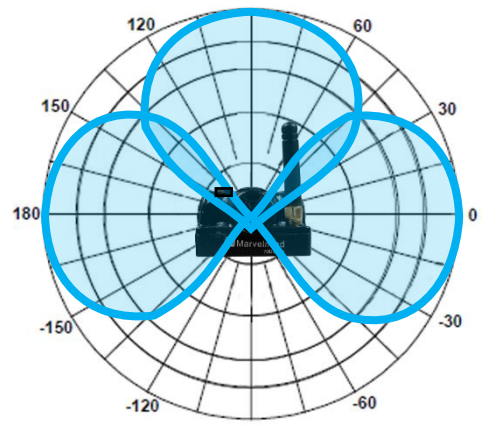

Figure 3 Transmitting diagram (with sensors)

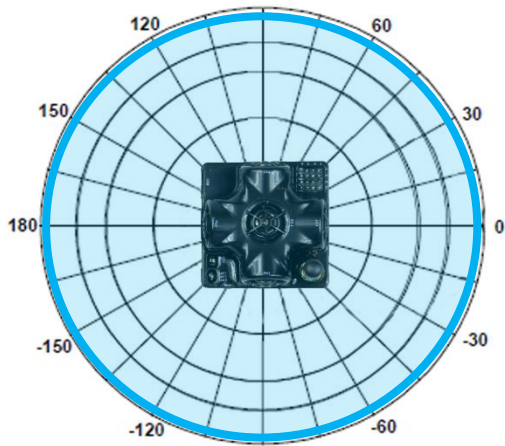

Figure 4 Receiving diagram (with digital microphone)

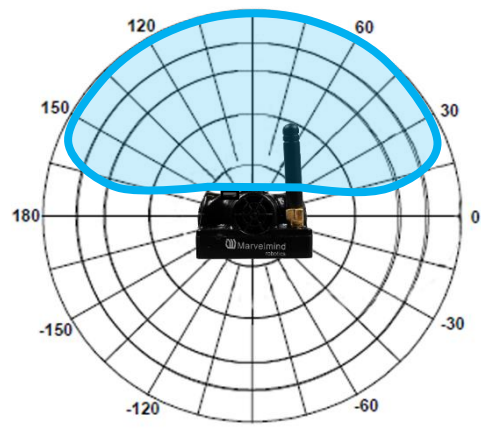

Figure 5 Receiving diagram (with digital microphone)

3.4.1.1. External microphone extension

This modification of the Super-Beacon allows you to bring the receiving microphone to any place on the robot or clothing. Due to this, the microphone body itself will not interfere, and will not be visible. It allows you to create more accurate implantation.

It is also possible to use 2 external microphones to calculate the direction, or to improve and increase the reception area.

Length is 25cm (default), may be expanded up to 1m (optional)



Be careful: You should have soldering skills to solder external microphone on board



Figure 2 Super-Beacon with one external microphone connected



Figure 3 Super-Beacon with two external microphones connected

External microphones schemes:



There can be some beacons (from one of the batches) with mixed default microphone wires' colors

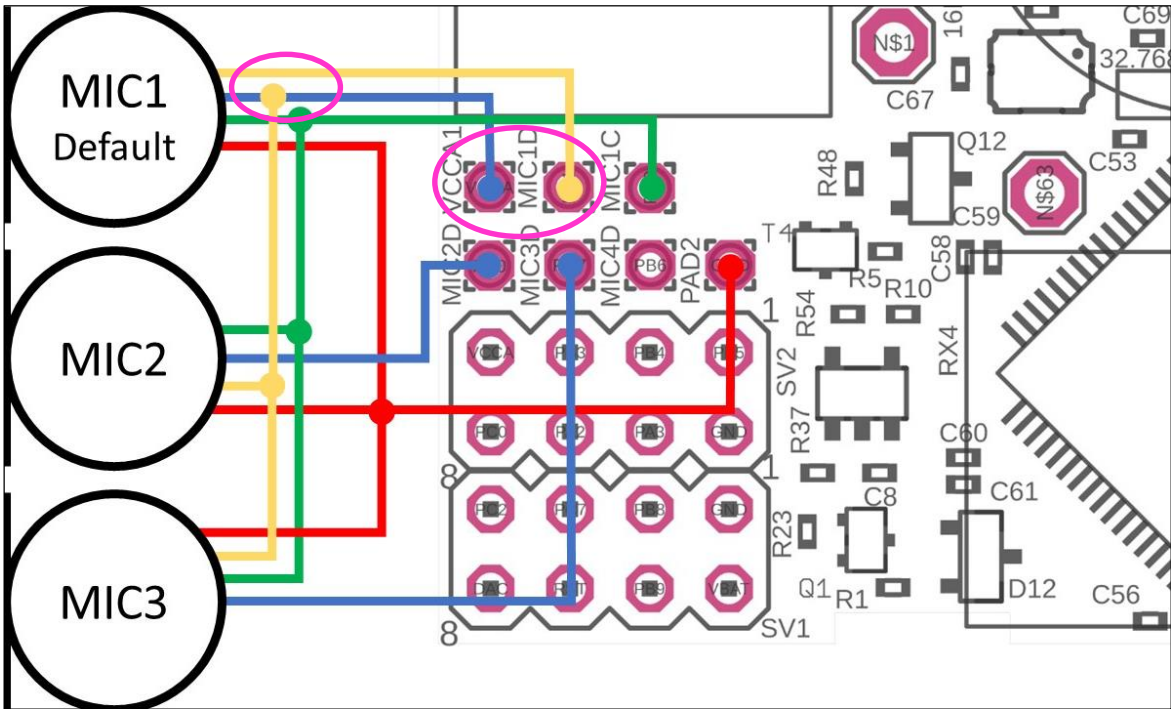

Figure 4 Connection for beacon with switched blue and yellow wires

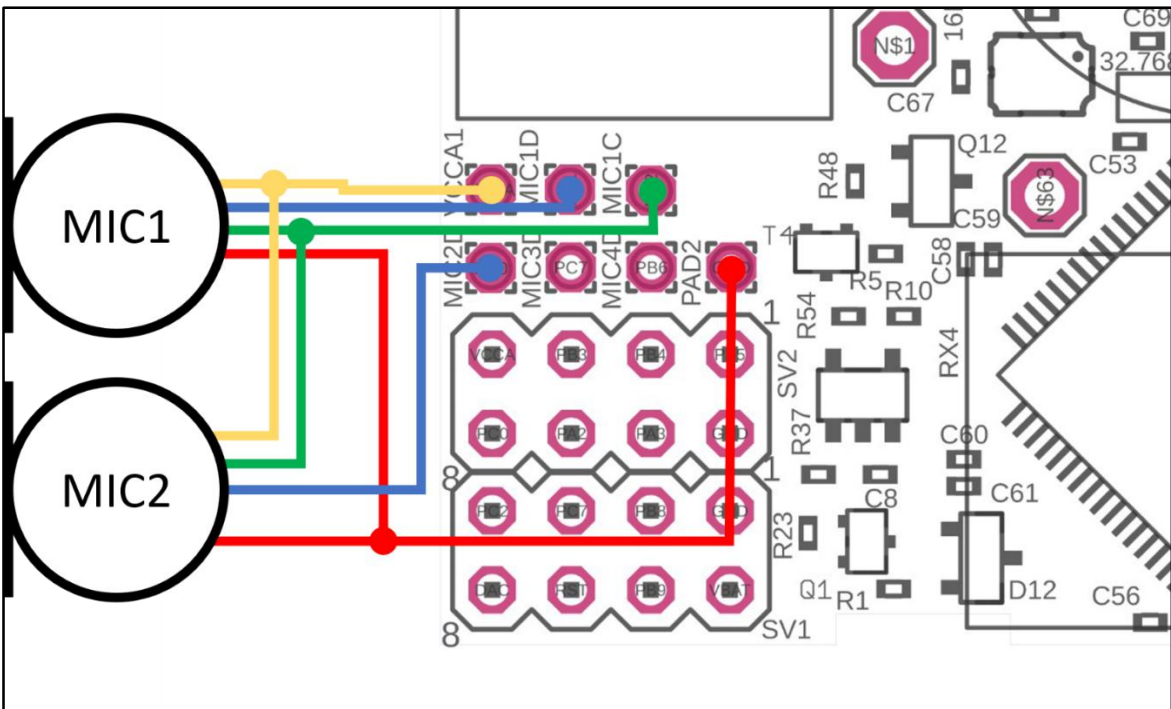

Figure 5 One external microphone connection

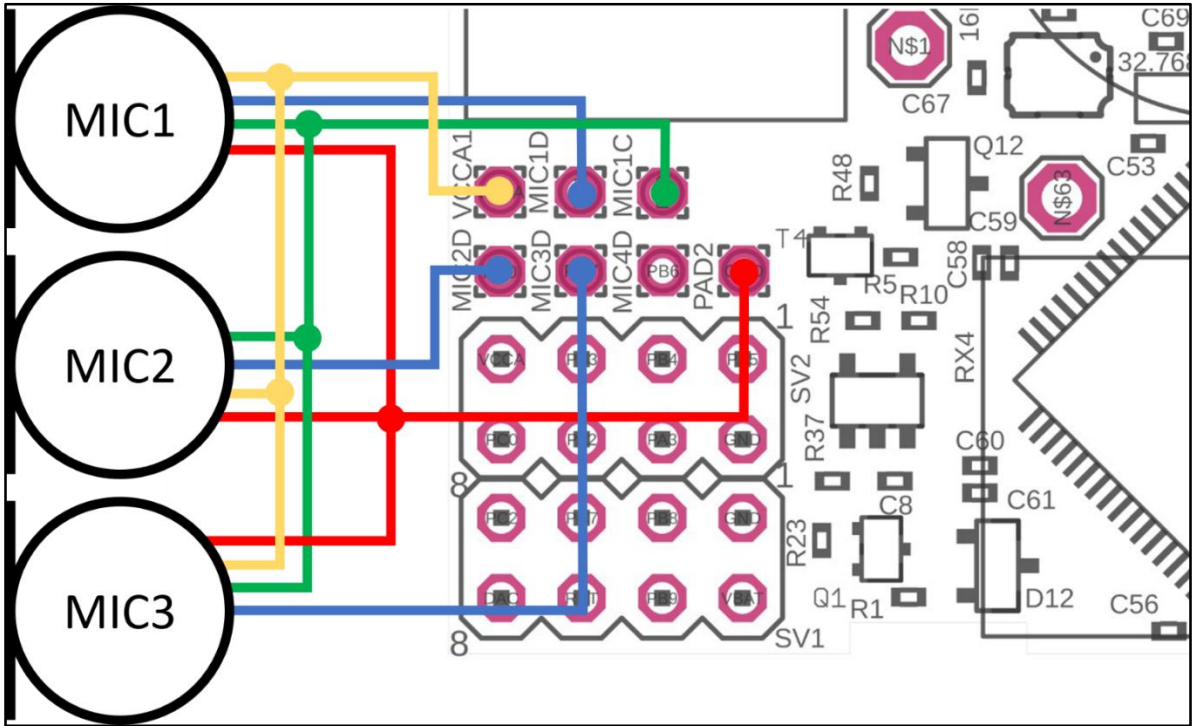

Figure 6 Two external microphone connection

3.4.2 Mini-RX beacon

The Mini-RX Beacon can be used in both the Non-Inverse Architecture (NIA) and in the Inverse Architecture (IA): [NIA and IA comparison](#)



The Mini-RX beacon HW differs from the regular Beacon HW v4.9 in several ways:

- It is an RX-only beacon, i.e. it can receive, but it cannot transmit ultrasonic signal
- The fact that it is RX-only makes it far more sensitive, i.e. you will get a longer range between Beacon HW v4.9 and Mini-RX v5.xx than between Beacon HW v4.9 and Beacon HW v4.9
- Mini-RX beacon can receive any ultrasonic frequency from the bands: 19kHz, 25kHz, 31kHz, 37kHz, 45kHz. The filter can be simply selected in the Dashboard. At the same time, the working ultrasonic frequency of Beacon HW v4.9 is HW-defined by ultrasonic sensors and can't be changed
- Mini-RX beacon can receive several ultrasonic frequencies at once. That is used in Inverse Architecture. See the comparison: [NIA and IA comparison](#)
- The Mini-RX Beacon is significantly smaller than Beacon HW v4.9
- Can play a role of stationary beacon when imputing coordinates manually
- Can play a role of mobile beacon (in IA system)
- Has digital microphone, which is more sensitive than regular sensors
- Supports 868/915MHz radio only
- Light weighted
- Can be [water-protected](#)
- The component of the [Marvelmind Helmet](#) and [Marvelmind Watch](#)
- It has 360° reception angle (horizontally) and 180° reception angle (vertically)

Reception diagram. Digital microphone has about 360° (horizontally) and 180° (vertically) reception angle

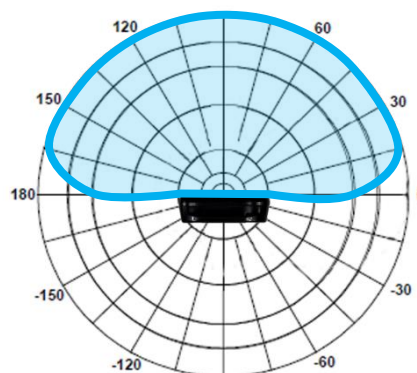
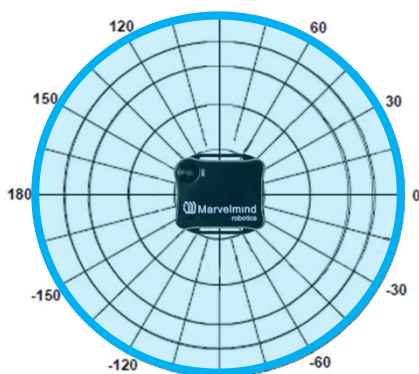

Mini-RX beacon may be over discharged. In that case do the following:

Turn off the beacon with DIP switches and charge it for 1 hour. Then turn the beacon on, flash the latest SW via DFU Programming and charge it for 1 hour again

3.4.2.1. External microphone extension

This modification of the Mini-RX beacon allows you to bring the receiving microphone to any place on the robot or clothing. Due to this, the microphone body itself will not interfere, and will not be visible. It allows you to create more accurate implantation.

It is also possible to use 2 external microphones to calculate the direction, or to improve and increase the reception area.

Length is 25cm (default), may be expanded up to 1m (optional)



Be careful: You should have soldering skills to solder external microphone on board

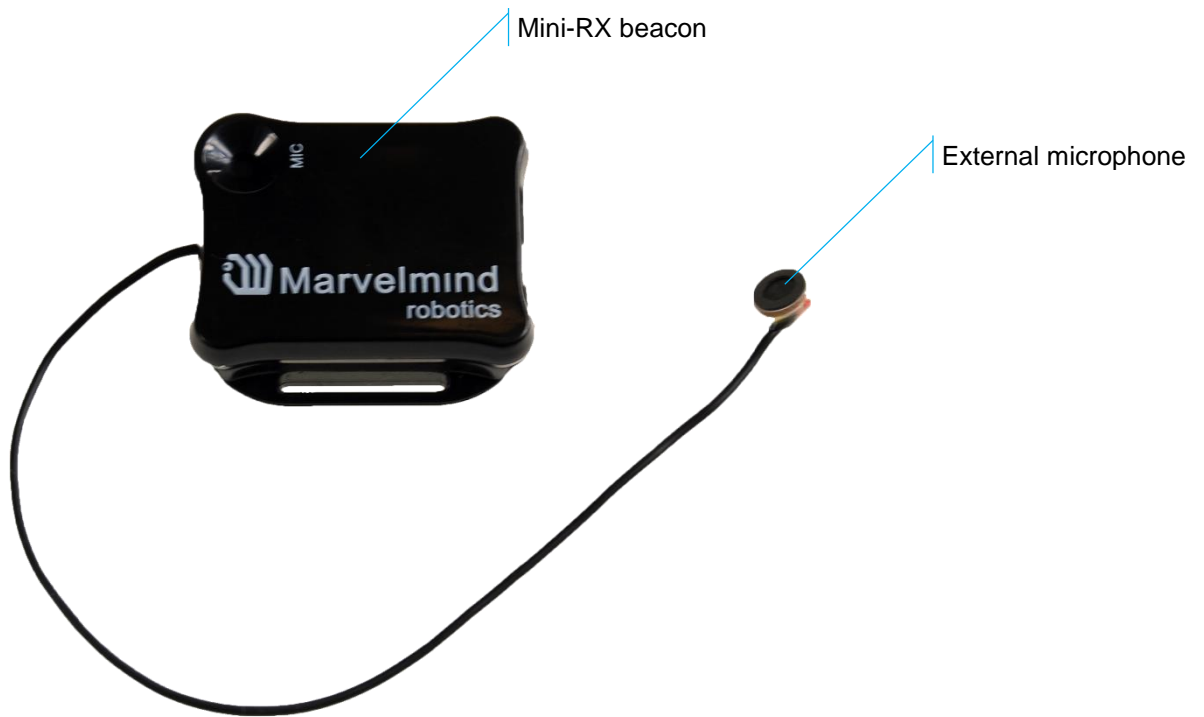

Dual microphones modification:

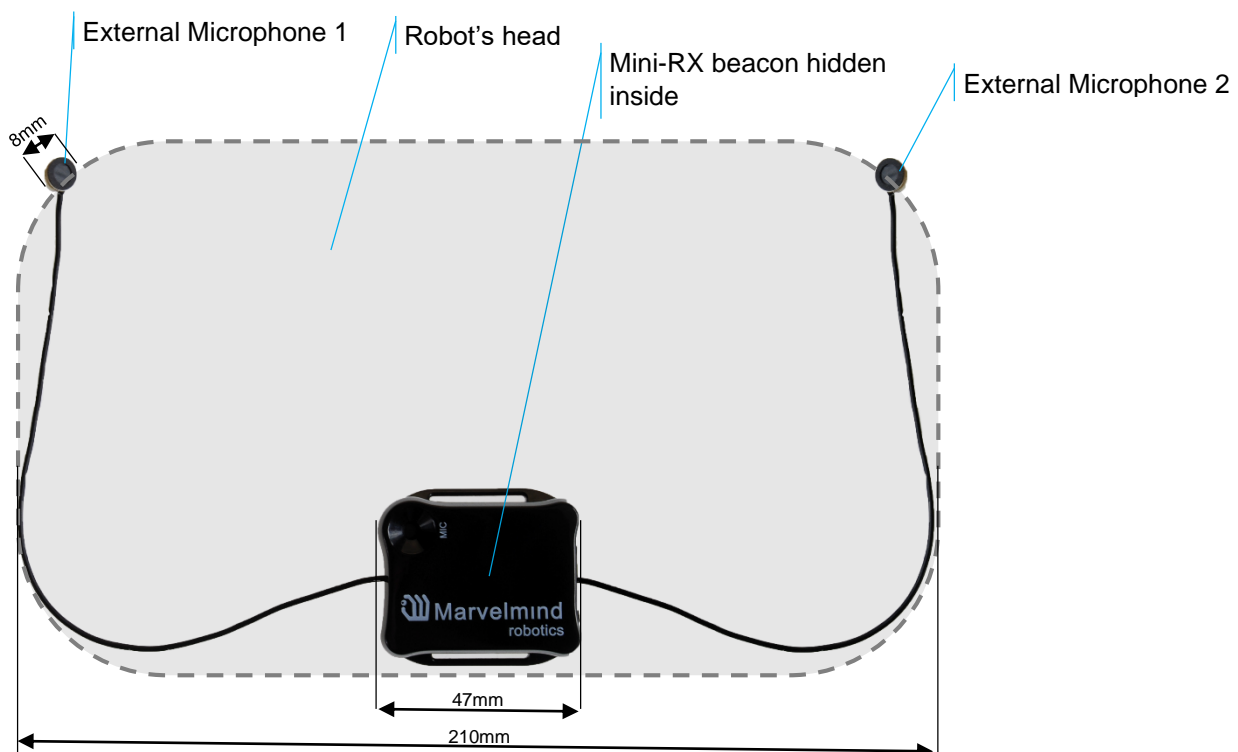



Figure 7 One external microphone with housing



Figure 8 Two external microphones with housing

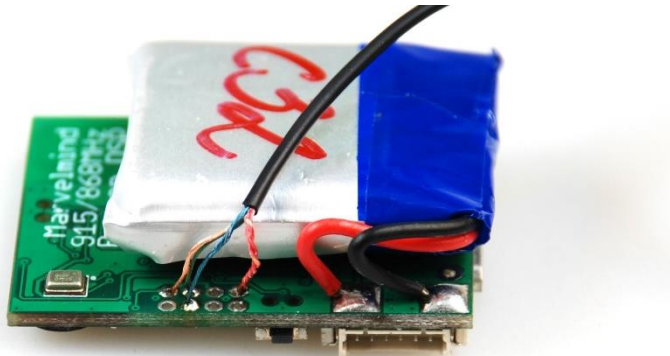

Figure 9 One external microphone soldering

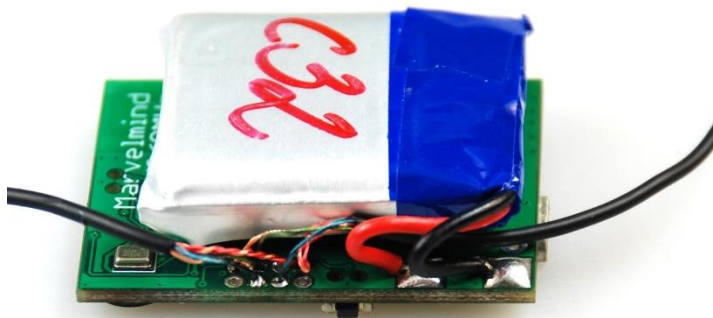

Figure 10 Two external microphones soldering

External microphones schemes:

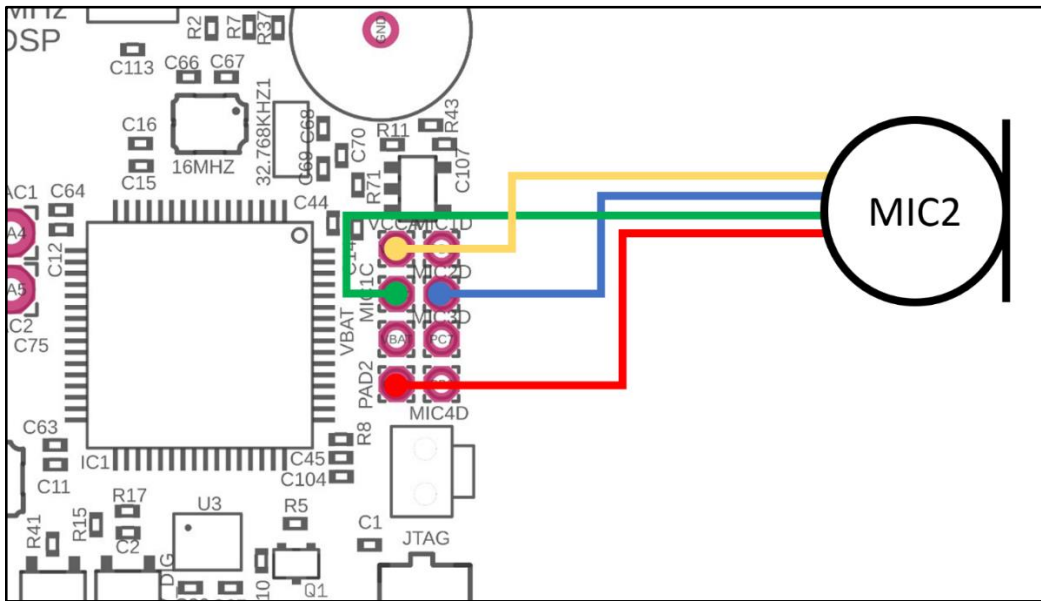

Figure 11 One external microphone connection

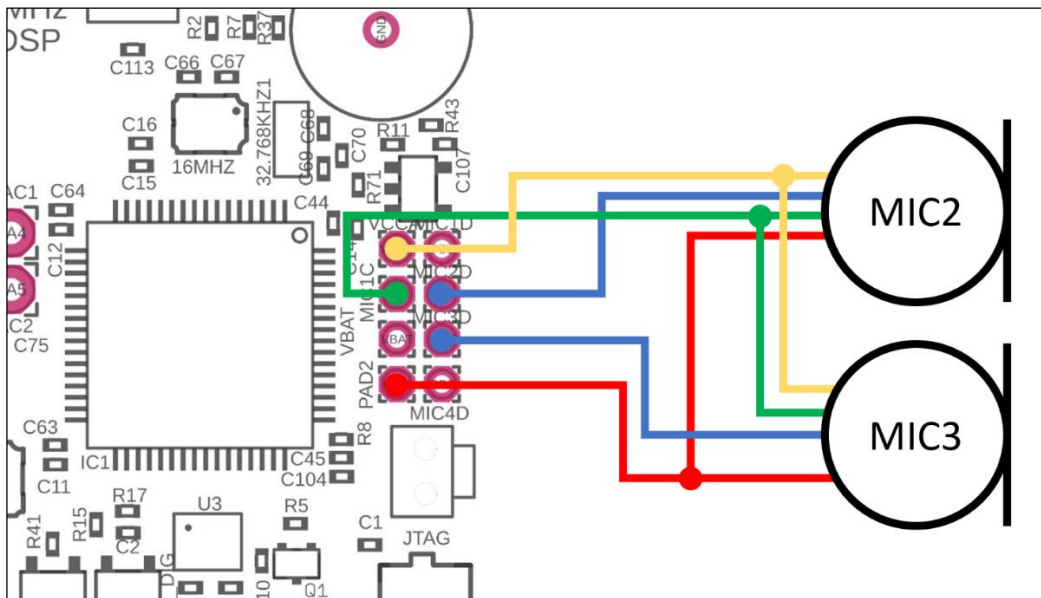

Figure 12 Two external microphones connection



Figure 13 Two external microphones final view



Figure 14 Two external microphones final view

3.4.3 Mini-TX beacon

The Mini-TX is a TX only beacon, i.e. it can transmit, but cannot receive ultrasound

Comparison to Beacon HW v4.9:

- Smaller size and lighter: 47x42x15mm & 25g vs. 55x55x33mm & 62g (or 55x55x64mm with antenna)
- TX only, i.e. Mini-TX can only transmit ultrasonic and cannot receive. Beacon HW v4.9 is dual use: can receive and transmit ultrasonic
- Battery – 250mAh vs. 1000mAh in a regular beacon. But Mini-TX has a new more efficient ultrasonic TX module, thus, battery lifetime in TX mode is even superior to the Beacon HW v4.9
- Tested battery lifetime with 8Hz – 96h. With lower update rate – nearly proportionally longer. Very efficient ultrasonic TX module
- Mini-TX has only USB (virtual UART) output – no additional pins
- Mini-TXs always have embedded IMU – newer and better, but it has 3D accelerometer and 3D gyroscope, but no magnetometer (which we do not recommend using indoors anyway, due to magnetic field distortion indoor)
- Embedded antenna – smaller size, but smaller radio coverage ~50m with regular Modem HW v4.9 as compared with ~100m of Beacon HW v4.9 with Modem HW v4.9
- Range in ultrasonic is virtually on par with regular Beacon HW v4.9 – up to 30m with Beacon HW v4.9 as RX beacon. At the same time, for example, a combination of Mini-RX RX beacon + Mini-TX TX provide a better coverage and a stronger signal, than Beacon HW v4.9 + Beacon HW v4.9
- This HW is for the 868/915MHz band only, i.e. 433MHz is not supported and not planned



3.4.4 [Beacon Industrial-TX-Metal](#)

- TX-only beacon – can transmit ultrasonic, but can't receive it
- Electronics is IP67 protected
- Special IP67-protected 25kHz transducers
- External antenna with SMA connector for extended radio range
- Corresponding IP67 connectors (male part) included
- No battery inside
- Extended working temperature range from -40°C to +50°C (not tested, provided by design)
- Embedded reset switch and DFU switch – magnetic control
- Two IP67 external connectors:



RS485 modification pinouts (After Sep.2019)

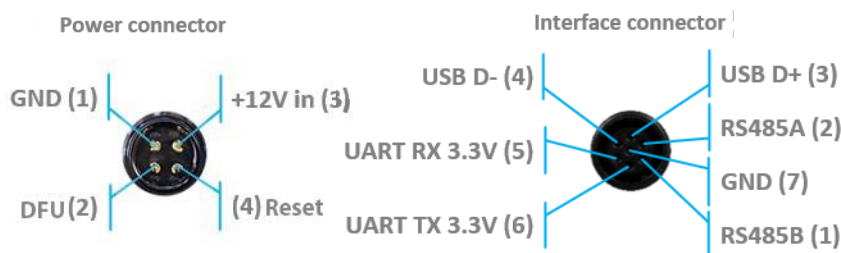

RS485 modification pinouts (Before Sep.2019)



CAN modification pinouts

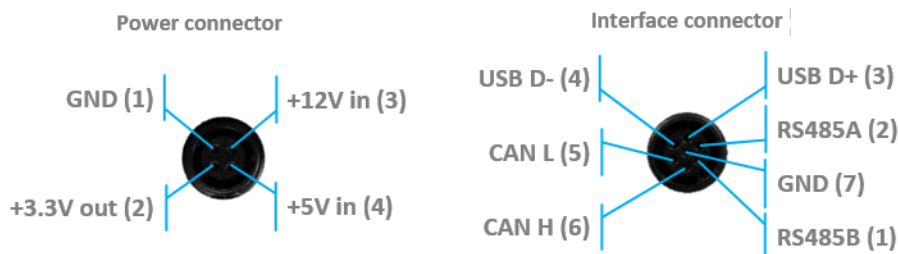

- Can work with any Mini-RX beacon or Beacon HW v4.9 with 25kHz ultrasonic sensors (radio bands must match)
- Most of all designed to work together with [Outdoor versions of Mini-RX](#) beacons and heavy outdoor Industrial-TX and Industrial-RX beacons (radio bands must match)
- Up to 30m with Beacon Mini-RX
- Optional external [Converter-220V-12V-IP67](#)



Uploading Beacon's Industrial-RX or Beacon's Industrial-TX SW to Industrial Super-beacon may permanently damage Industrial Super-Beacon board.



Determine carefully the version of your Industrial beacons: it may be built before September 2019 and after September 2019. If it is beacon from the late batch, you must use Industrial Super-beacon SW. if you have beacons from the early batch, use Industrial-RX or Industrial-TX SW. Stickers' differences: Later batch – Ind-RX-S or Ind-TX-S. Early batch – Beacon Ind-RX or Beacon Ind-TX.



3.4.5 [Beacon Industrial-RX](#)

- RX-only beacon – can receive ultrasonic, but can't transmit it
- Electronics is IP67 protected
- Special IP67-membrane for ultrasonic sensor
- External antenna with SMA connector for extended radio range
- Corresponding IP67 connectors (male part) included
- No battery inside by default – external power bank or external power supply (+12V Or +5V). But, optional variant with internal battery is possible
- Two IP67 external connectors:



RS485 modification pinouts (After Sep.2019)

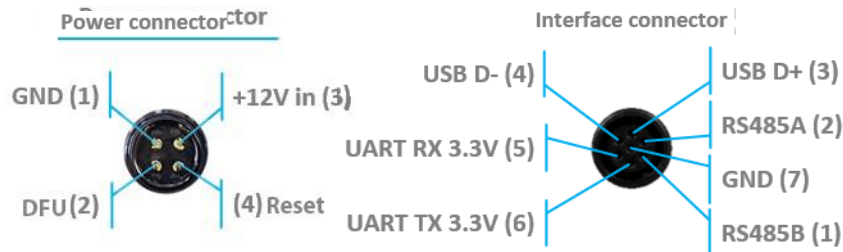

RS485 modification pinouts (Before Sep.2019)



CAN modification pinouts



- Extended working temperature range from -40°C to +50°C (not tested, provided by design) – only for the version without battery
- Embedded reset switch and DFU switch – magnetic control
- Supports wide range of ultrasonic frequencies: 19/25/31/37/45kHz
- Most of all designed to work together with [Outdoor versions of Mini-RX](#) beacons and heavy outdoor Industrial-TX and Industrial-RX beacons (radio bands must match)
- Optional external [Converter-220V-12V-IP67](#)



Uploading Beacon's Industrial-RX or Beacon's Industrial-TX SW to Industrial Super-beacon may permanently damage Industrial Super-beacon board.



Determine carefully the version of your Industrial beacons: it may be built before September 2019 and after September 2019. If it is beacon from the late batch, you must use Industrial Super-beacon SW. if you have beacons from the early batch, use Industrial-RX or Industrial-TX SW. Stickers' differences: Later batch – Ind-RX-S or Ind-TX-S. Early batch – Beacon Ind-RX or Beacon Ind-TX.

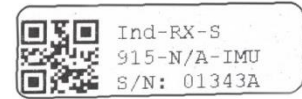
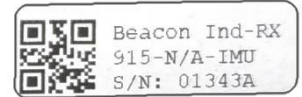

3.4.6 Industrial Super-Beacon Metal-25kHz

- Supports dual-use – RX and TX beacon. It can transmit on its native ultrasonic frequency (25kHz) and it can receive on any ultrasonic frequency via an embedded RX sensor – like Industrial-RX or Mini-RX does. Effectively, the Industrial Super-Beacons beacons combines inside an Industrial-TX and Industrial-RX. Additionally, the beacon supports both AI and NIA architectures. Thus, it is called Industrial Super-Beacon
- Electronics is IP67 protected
- Special IP67-protected 25-kHz transducers
- External antenna with SMA connector for extended radio range
- Corresponding IP67 connectors (male part) included
- No battery inside
- Extended working temperature range from -40°C to +50°C (not tested, provided by design)
- Embedded reset switch and DFU switch – magnetic control
- Two IP67 external connectors:
RS485 modification pinouts

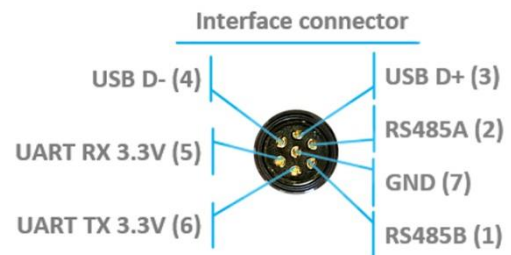
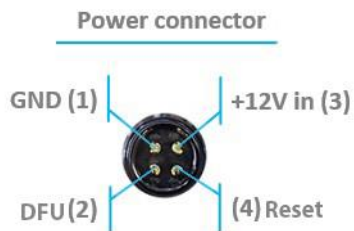

- Can work together with modems with corresponding radio (radio bands must match)
- Can work with any Mini-RX beacon or Beacon HW v4.9 with 25kHz ultrasonic sensors (radio bands must match)
- Most of all designed to work together with [Outdoor versions of Mini-RX](#) beacons and heavy outdoor Industrial-TX and Industrial-RX beacons (radio bands must match)
- Up to 30m with Beacon Mini-RX
- Optional external [Converter-220V-12V-IP67](#)



Uploading Beacon Industrial's (Not super) DFU software to Industrial Super-Beacon hardware make permanently damage for Industrial Super-Beacon board. Be double attentive with update

3.4.7 HW v4.9 beacon



HW v4.9 beacon can be used in both the Non-Inverse Architecture (NIA) and in the Inverse Architecture (IA): [NIA and IA comparison](#)

Reception diagram. Each sensor has about 90° reception angle:

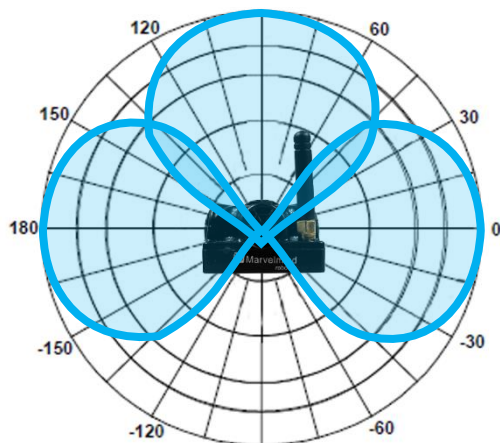

Figure 1 Transmitting diagram (with sensors)

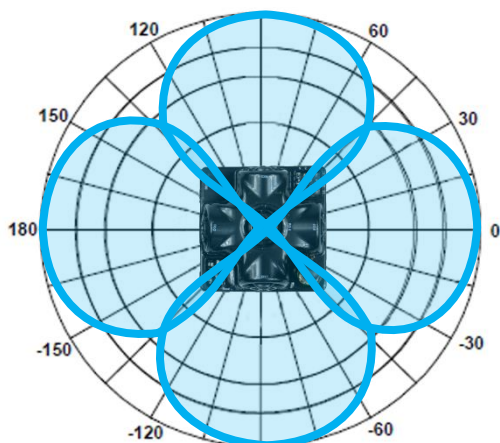

Figure 15 Transmitting diagram (with sensors)

3.6 Beacon comparison



Here you can see more details about the different types of beacons:
https://marvelmind.com/pics/marvelmind_beacons_comparison.pdf

4. Setting up the system (NIA)

4.1 Starter Set Super-NIA-3D

The steps below describe the very first time you set up of the system. Super-beacons and modem required.



4.1.5 Unpack the system. Look at a similar unpacking video of HW v4.9. The videos have certain differences but the basic are the same: https://youtu.be/sOce7B2_6Sk

4.1.6 Charge all the beacons using USB cable. Full charging takes about 1-2 hours

4.1.7 Turn the beacons on: Place DIP switches as shown on the picture below

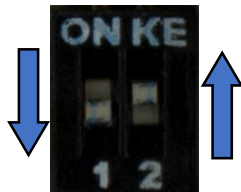

4.1.8 Download [SW Pack](#)

4.1.9 Update all the beacons (HEX programming):

- Run the Dashboard and update the SW for all beacons and modem using Dashboard => Firmware => Choose the file => Program

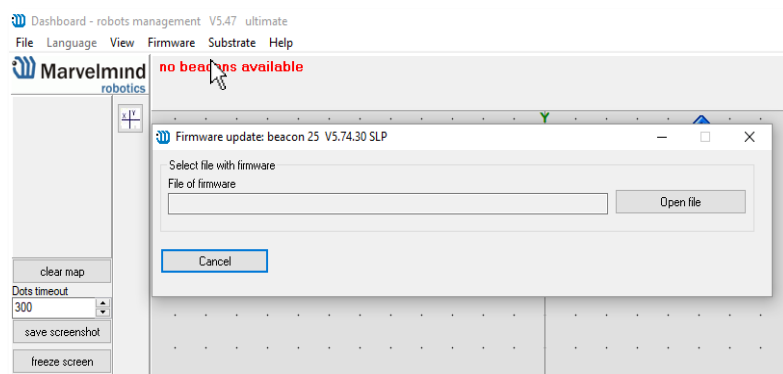

- If you see the message “Not found modem connection to computer through USB” in the Dashboard or your PC does not recognize beacons/modem, it usually means that the STM32 driver is not installed. To install the driver, download it with link at top window in the Dashboard and run the installation file, then click on the link under and install the driver

Ensure that:

- (a) You are programming the modem’s SW to the modem and the beacon’s SW to the beacon
- (b) You are using SW for Super-beacon, if you have Super-beacon; and you have the SW from the same SW pack, i.e., the Dashboard SW, modem SW, and beacon SW must be from the same SW pack. Don’t mix SW releases



If SW flashed SUCESFULLY, MOVE DIRECTLY TO 4.1.10. If you have some problems with HEX programming, use DFU programming:

DFU programming or SW uploading is used when HEX SW uploading in the Dashboard cannot be used. For example, when you are updating from a very old SW version or when the SW includes major changes to the system and the only possible way to update the SW is via DFU programming

- After the DFU SW upgrade, future SW upgrades can be done in a regular manner via the Dashboard
- To start programming, move the beacon’s DIP switch to the DFU programming mode, as described in the paragraph on [DIP switch modes](#)
- Download the latest [SW package](#), unzip it, and select the proper version of the SW for your HW and for your frequency variant. Remember that for DFU programming, you should use DFU SW (DfuSe), not Dashboard’s .hex file
- Download DfuSe
- Here you will find different versions of DfuSe. v3.0.4 or v3.0.5, whichever works the best for your Windows: [DfuSe v3.0.4](#) or [DfuSe v.3.0.5](#)

DFU Programming:

- Put DIP switch into **Power = ON, DFU = ON**
- Connect the beacon via USB to your PC
- Run DfuSe
- Press the **RESET** button on your beacon
- In the upper left corner of the DfuSe program, you will see a device connected in the DFU mode



- Choose the DFU driver (file) for the beacon

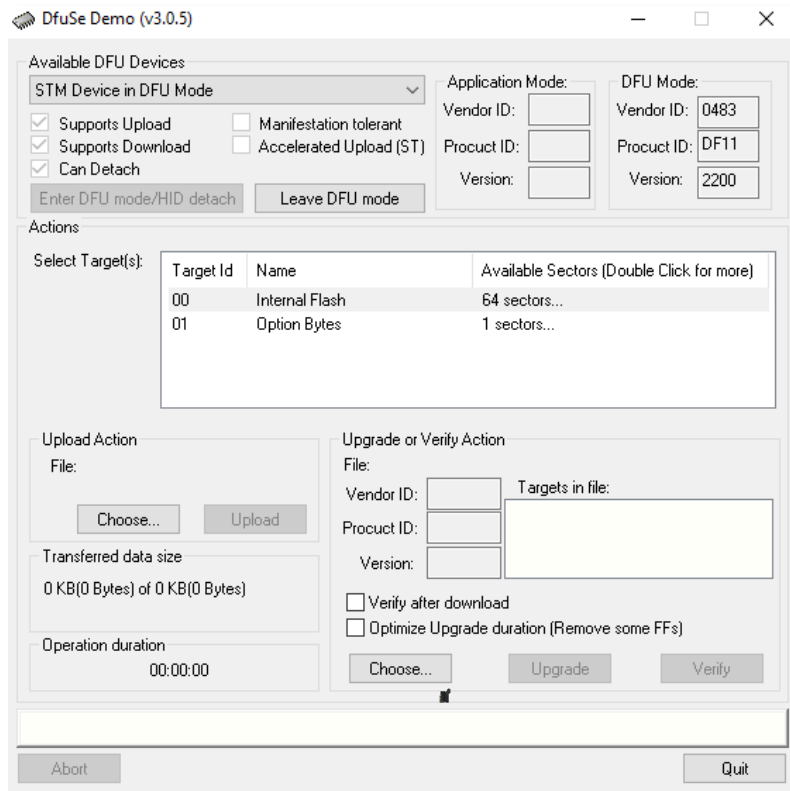

- Click the **UPGRADE** button
- After a couple of seconds, the DFU will be uploaded to the beacon. Make sure it takes 1–3 seconds and does not happen instantly. Otherwise, the SW has not been uploaded correctly. If the DFU appears to upload immediately, check the "Choose" button you used or change the version of DfuSe SW you selected
- Move the DIP switch into **Power = ON, DFU = OFF**
- Start the Dashboard and press the **RESET** button on the beacon
- Check SW on the beacon afterwards
- Everything should be OK with SW now. DFU programming is complete

- Follow the same scenario for the modem:

- Here is the [link](#) for the modem DFU programming. The steps are similar to those for beacon DFU programming
- After uploading DFU driver by DfuSe short circuit pins as shown on the picture (for v4.9) and press **Reset** button

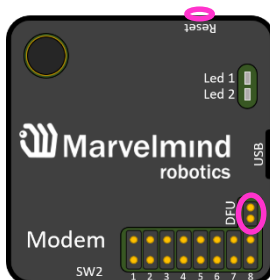

- Modem will go to DFU mode. Press **UPGRADE** button in the DfuSe program
- After a couple of seconds, the DFU will be uploaded to the modem. Make sure it takes 1-3 seconds and does not happen immediately. Otherwise, the SW has not been uploaded correctly. If the DFU appears to upload immediately, check the "Choose" button you used or change the version of DfuSe SW to a different one
- Disconnect the short circuit
- Start the Dashboard and press **RESET** button
- If you experience difficulties in DFU programming, please try the following:
 - Use a different computer with a different version of Windows or another operating system
 - Install a different DfuSe version (whichever works best with your Windows)

If you have uploaded the latest firmware for all the boards, you can start to activate the system:

- 4.1.10 While the beacon or modem is connected to the Dashboard, click the **DEFAULT** button on the Dashboard to upload the default settings

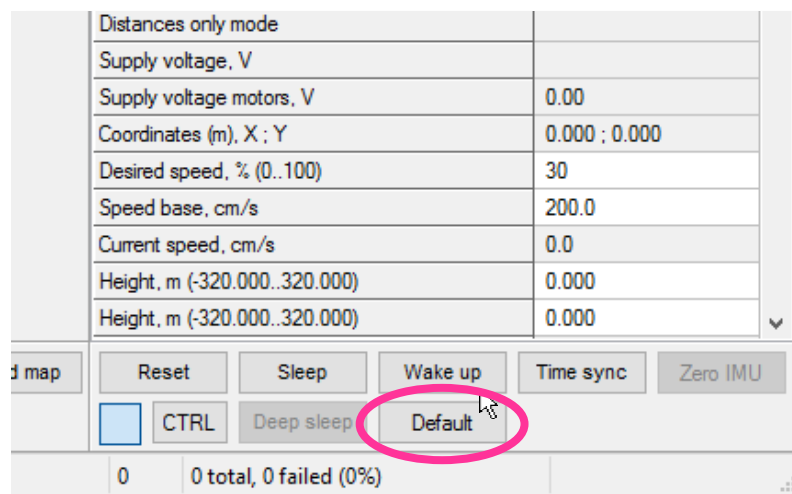

- 4.1.11 Write down the beacon's address for future use or change the address at your convenience as shown here

Reegenog mode	enabled
Inverse system	enabled
Distances only mode	disabled
Supply voltage, V	3.70
Desired speed, % (0..100)	30
Time from reset, h:m:s	00:00:04 R
Measured temperature, °C	23
RSSI, dBm	-74
Radio frequency band	915 MHz
Carrier frequency, MHz	919.000
Device address (0..254)	154
Radio channel	0
Ultrasonic frequency, Hz (100..65000)	n/a
Filter selection	n/a
IMU	(+) expand
Parameters of radio	(+) expand
Ultrasound	(+) expand
Interfaces	(+) expand
Georeferencing	(+) expand
Misc. settings	(+) expand
Hedgehogs pairing	(+) expand
Real-time player	disabled
Real-time player backward (0..127)	3
Real-time player forward (0..127)	5

- 4.1.12 Press the RESET button on your beacons and modem after programming
- 4.1.13 After programming devices with the latest software, the modem and beacons are ready for use
- 4.1.14 Place the stationary beacons high on the walls vertically in a way that will provide optimal ultrasonic coverage. Write down the beacon's height for future change in the settings. The help video on installation can be found here - <https://youtu.be/WYOHkLzmijs>
- 4.1.15 Connect the modem/router via USB to a Windows PC with the Dashboard installed
- 4.1.16 Run the Dashboard. In the left corner of the Dashboard, the modem should be shown as connected
- 4.1.17 Wake up all beacons by selecting them on the Dashboard panel



Only 4 stationary beacons may be in 1 submap. If you wake up more beacons, create new submap for them or it won't be displayed on the map and in the table of distances.

4.1.18 It may take up to 7-10 seconds for the beacons to wake up

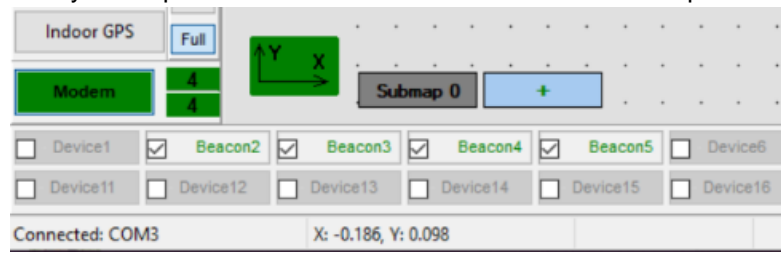

4.1.19 Notice, that if the modem is not active and is not powered, the beacons will go into sleep mode automatically after 1 minute

4.1.20 The system may run the frequency search, if it is the very first time you are waking up the beacons. If this step does not work, disconnect the modem and connect that beacon again via USB. Press the DEFAULT button in the Dashboard and the Read All button to make sure that the radio settings are the default ones

4.1.21 Check that the radio settings on the modem and the radio settings on the beacon are the same

4.1.22 Now you can check RSSI, voltage, ultrasonic filter settings, etc. on the panel on the right corner of the Dashboard

Supply voltage, V	3.95
Desired speed, % (0..100)	30
Height, m (-320.000..320.000)	0.000
Time from reset, h:m:s	00:01:26 R
Measured temperature, °C	23
RSSI, dBm	-28
Radio frequency band	915 MHz
Carrier frequency, MHz	919.000
Device address (0..254)	30
Radio channel	0
Ultrasonic frequency, Hz (100..65000)	25000
Filter selection	31 kHz

4.1.5 Enter the height of stationary beacons. Choose beacon in the list and enter height value

Read all		Write all	
CPU ID	Copy to clipboard	013326	
Firmware version	V6.192 Super-Beacon		
Power save functions	enabled		
Hedgehog mode	enabled		
Inverse system	disabled		
Distances only mode	disabled		
Supply voltage, V	3.95		
Desired speed, % (0..100)	30		
Height, m (-320.000..320.000)	0.000		
Time from reset, h:m:s	00:01:26 R		
Measured temperature, °C	23		
RSSI, dBm	-28		
Radio frequency band	915 MHz		
Carrier frequency, MHz	919.000		
Device address (0..254)	30		
Radio channel	0		
Ultrasonic frequency, Hz (100..65000)	25000		
Filter selection	31 kHz		



4.1.6 Enter the height for mobile beacon if you use 2D mode

4.1.7 In the current version one modem supports 250 beacons (mobile + stationary combined). If you do not see some of your connected beacons on the map, you may need to scroll to find their addresses

4.1.8 Double click on the device both to put it into sleep mode and to wake it up

4.1.9 The map will form and zoom in automatically

- 4.1.10 If the map does not form well, check the table of distances in the left corner of the Dashboard. The cells must be colored in white; it means the distances between stationary beacons are measured correctly

Dashboard - robots management V5.47 ultimate
File Language View Firmware Substrate Help

Marvelmind robotics

HIDE	22	23	24	25	26
22		10.394	11.365	9.992	
23	10.394		6.621	10.262	
24	11.365	6.621		4.873	
25	9.992	10.262	4.873		
26	10.088	7.094	1.937	3.659	

clear map
Dots timeout: 300
save screenshot
freeze screen

X=0.280
Y=4.380
Z=1.800

- 4.1.11 If you see in the table some empty cells or marked yellow/red, it is an indication that distances between Some beacons are measured inconsistently or not measured at all. Try to re-position them because usually there is an obstruction of some sort in the between the beacons. If you have any problems – check [Table of distances](#) chapter
- 4.1.12 Make a service zone, clicking on the map with **Shift+Left Mouse Button**. See [Submaps chapter](#) for more details
- 4.1.13 Freeze the map by clicking the button. Stationary beacons will stop measuring relative distances and will be ready to measure distance from the mobile beacon(s)

save map load map
erase map

146 total, 1 failed (1%)



- 4.1.14 Turn on and wake up the mobile beacon following the same steps as with the stationary beacon. More details in our video: <https://youtu.be/A4aRsjH2-E>
- 4.1.15 If you see on the devices' panel in the Dashboard that the beacon is colored orange, it means there are some differences in some of the settings between beacons. For example, some sensors may be off or some ultrasonic or radio settings may be different. You can change the settings for sensors manually by clicking on the panel on the upper right corner of the Dashboard to change the cells from gray to green to turn on sensor. It is recommended that the default settings on all beacons and the modem are used if this is your first time using the system.
- 4.1.16 After you freeze the map of stationary beacons, wake up the mobile beacon. After it wakes up, it will be traceable within 5-7 seconds.
- 4.1.17 The system is now fully operational.



4.1.18 In the dashboard, you can upload a picture / map of your room. You can use a different picture for every floor. Go to [Loading the floorplan](#) (Help video: <https://www.youtube.com/watch?v=NHUnCtJIYXc>)

4.2 Starter Set HW v4.9

The steps below describe the very first time you set up of the system. Beacons HW v4.9 and modem required.



4.2.1 Unpack the system. Watch the help video:

https://youtu.be/sOce7B2_6Sk

4.2.2 Charge all the beacons using USB cable. Full charging takes about 1-2 hours

4.2.3 Turn the beacons on: Place DIP switches as shown on the picture below

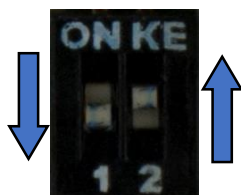

4.2.4 Download [SW Pack](#)

4.2.5 Update all the beacons (HEX programming):

- Run the Dashboard and update the SW for all beacons and modem using Dashboard => Firmware => Choose the file => Program
- If you see the message “Not found modem connection to computer through USB” in the Dashboard or your PC does not recognize beacons/modem, it usually means that the STM32 driver is not installed. To install the driver, download it with link at top window in the Dashboard and run the installation file, then click on the link under and install the driver

Ensure that:

- (c) You are programming the modem's SW to the modem and the beacon's SW to the beacon
- (d) You are using SW for HW v4.9, if you have HW v4.9; and you have the SW from the same SW pack, i.e., the Dashboard SW, modem SW, and beacon SW must be from the same SW pack. Don't mix SW releases



If SW flashed SUCESSUFLY, MOVE DIRECTLY TO 4.2.6. If you have some problems with HEX programming, use DFU programming:

DFU programming or SW uploading is used when HEX SW uploading in the Dashboard cannot be used. For example, when you are updating from a very old SW version or when the SW includes major changes to the system and the only possible way to update the SW is via DFU programming

- After the DFU SW upgrade, future SW upgrades can be done in a regular manner via the Dashboard
- To start programming, move the beacon's DIP switch to the DFU programming mode, as described in the paragraph on [DIP switch modes](#)
- Download the latest [SW package](#), unzip it, and select the proper version of the SW for your HW and for your frequency variant. Remember that for DFU programming, you should use DFU SW (DfuSe), not Dashboard's .hex file
- Download DfuSe
- Here you will find different versions of DfuSe. v3.0.4 or v3.0.5, whichever works the best for your Windows: [DfuSe v3.0.4](#) or [DfuSe v.3.0.5](#)

DFU Programming:

- Put DIP switch into **Power = ON, DFU = ON**
- Connect the beacon via USB to your PC
- Run DfuSe
- Press the **RESET** button on your beacon
- In the upper left corner of the DfuSe program, you will see a device connected in the DFU mode

- Choose the DFU driver (file) for the beacon

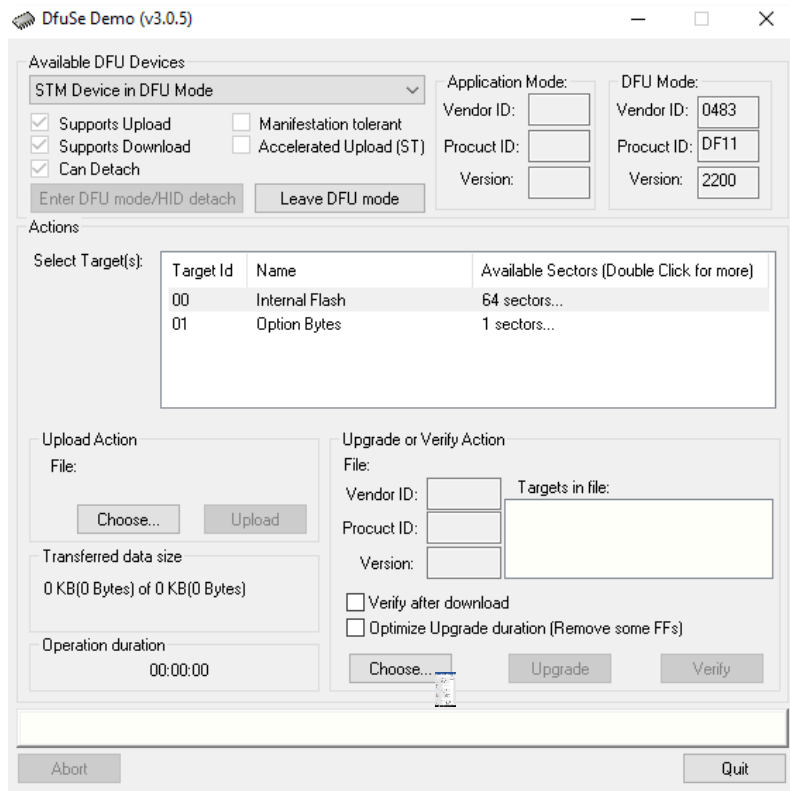

- Click the **UPGRADE** button
- After a couple of seconds, the DFU will be uploaded to the beacon. Make sure it takes 1–3 seconds and does not happen instantly. Otherwise, the SW has not been uploaded correctly. If the DFU appears to upload immediately, check the "Choose" button you used or change the version of DfuSe SW you selected
- Move the DIP switch into **Power = ON, DFU = OFF**
- Start the Dashboard and press the **RESET** button on the beacon
- Check SW on the beacon afterwards
- Everything should be OK with SW now. DFU programming is complete
- Follow the same scenario for the modem:
 - Here is the [link](#) for the modem DFU programming. The steps are similar to those for beacon DFU programming
 - After uploading DFU driver by DfuSe short circuit pins as shown on the picture (for v4.9) and press **Reset** button

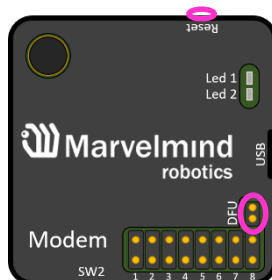

- Modem will go to DFU mode. Press **UPGRADE** button in the DfuSe program
- After a couple of seconds, the DFU will be uploaded to the modem. Make sure it takes 1-3 seconds and does not happen immediately. Otherwise, the SW has not been uploaded correctly. If the DFU appears to upload immediately, check the "Choose" button you used or change the version of DfuSe SW to a different one
- Disconnect the short circuit
- Start the Dashboard and press **RESET** button
- If you experience difficulties in DFU programming, please try the following:
 - Use a different computer with a different version of Windows or another operating system
 - Install a different DfuSe version (whichever works best with your Windows)

If you have uploaded the latest firmware for all the boards, you can start to activate the system:

- 4.2.6 While the beacon or modem is connected to the Dashboard, click the **DEFAULT** button on the Dashboard to upload the default settings

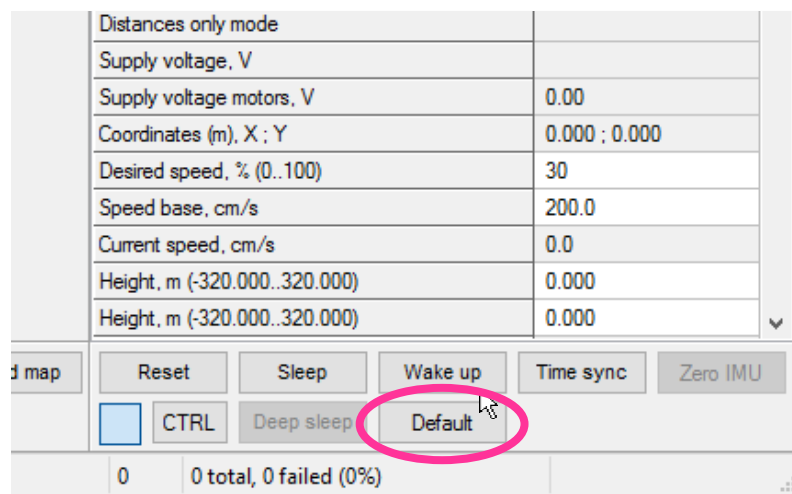

- 4.2.7 Write down the beacon's address for future use or change the address at your convenience as shown here

Reegenog mode	enabled
Inverse system	enabled
Distances only mode	disabled
Supply voltage, V	3.70
Desired speed, % (0..100)	30
Time from reset, h:m:s	00:00:04 R
Measured temperature, °C	23
RSSI, dBm	-74
Radio frequency band	915 MHz
Carrier frequency, MHz	919.000
Device address (0..254)	154
Radio channel	0
Ultrasonic frequency, Hz (100..65000)	n/a
Filter selection	n/a
IMU	(+) expand
Parameters of radio	(+) expand
Ultrasound	(+) expand
Interfaces	(+) expand
Georeferencing	(+) expand
Misc. settings	(+) expand
Hedgehogs pairing	(+) expand
Real-time player	disabled
Real-time player backward (0..127)	3
Real-time player forward (0..127)	5

- 4.2.8 Press the RESET button on your beacons and modem after programming
- 4.2.9 After programming devices with the latest software, the modem and beacons are ready for use
- 4.2.10 Place the stationary beacons high on the walls vertically in a way that will provide optimal ultrasonic coverage. Write down the beacon's height for future change in the settings. The help video on installation can be found here - <https://youtu.be/WYOHkLzmjys>
- 4.2.11 Connect the modem/router via USB to a Windows PC with the Dashboard installed
- 4.2.12 Run the Dashboard. In the left corner of the Dashboard, the modem should be shown as connected
- 4.2.13 Wake up all beacons by selecting them on the Dashboard panel



Only 4 stationary beacons may be in 1 submap. If you wake up more beacons, create new submap for them or it won't be displayed on the map and in the table of distances.

4.2.14 It may take up to 7-10 seconds for the beacons to wake up

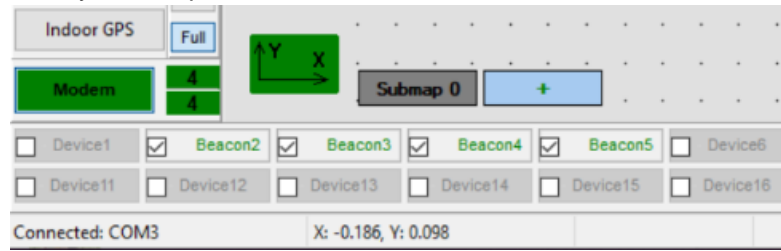

4.2.15 Notice, that if the modem is not active and is not powered, the beacons will go into sleep mode automatically after 1 minute

4.2.16 The system may run the frequency search, if it is the very first time you are waking up the beacons. If this step does not work, disconnect the modem and connect that beacon again via USB. Press the DEFAULT button in the Dashboard and the Read All button to make sure that the radio settings are the default ones

4.2.17 Check that the radio settings on the modem and the radio settings on the beacon are the same

4.2.18 Now you can check RSSI, voltage, ultrasonic filter settings, etc. on the panel on the right corner of the Dashboard

Supply voltage, V	3.95
Desired speed, % (0..100)	30
Height, m (-320.000..320.000)	0.000
Time from reset, h:m:s	00:01:26 R
Measured temperature, °C	23
RSSI, dBm	-28
Radio frequency band	915 MHz
Carrier frequency, MHz	919.000
Device address (0..254)	30
Radio channel	0
Ultrasonic frequency, Hz (100..65000)	25000
Filter selection	31 kHz

4.2.19 Enter the height of stationary beacons. Choose beacon in the list and enter height value

Read all		Write all	
CPU ID	Copy to clipboard	013326	
Firmware version	V6.192 Super-Beacon		
Power save functions	enabled		
Hedgehog mode	enabled		
Inverse system	disabled		
Distances only mode	disabled		
Supply voltage, V	3.95		
Desired speed, % (0..100)	30		
Height, m (-320.000..320.000)	0.000		
Time from reset, h:m:s	00:01:26 R		
Measured temperature, °C	23		
RSSI, dBm	-28		
Radio frequency band	915 MHz		
Carrier frequency, MHz	919.000		
Device address (0..254)	30		
Radio channel	0		
Ultrasonic frequency, Hz (100..65000)	25000		
Filter selection	31 kHz		



4.2.20 Enter the height for mobile beacon if you use 2D mode

4.2.21 In the current version one modem supports 250 beacons (mobile + stationary combined). If you do not see some of your connected beacons on the map, you may need to scroll to find their addresses

4.2.22 Double click on the device both to put it into sleep mode and to wake it up

4.2.23 The map will form and zoom in automatically

- 4.2.24 If the map does not form well, check the table of distances in the left corner of the Dashboard. The cells must be colored in white; it means the distances between stationary beacons are measured correctly

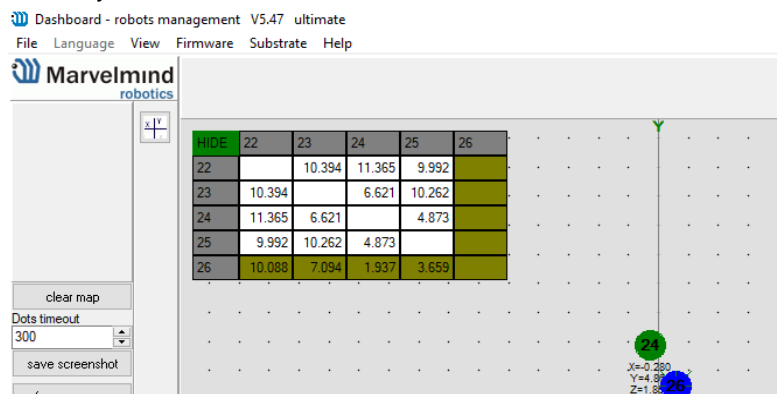

- 4.2.25 If you see in the table some empty cells or marked yellow/red, it is an indication that distances between Some beacons are measured inconsistently or not measured at all. Try to re-position them because usually there is an obstruction of some sort in the between the beacons. If you have any problems – check [Table of distances](#) chapter
- 4.2.26 Make a service zone, clicking on the map with **Shift+Left Mouse Button**. See [Submaps chapter](#) for more details
- 4.2.27 Freeze the map by clicking the button. Stationary beacons will stop measuring relative distances and will be ready to measure distance from the mobile beacon(s)

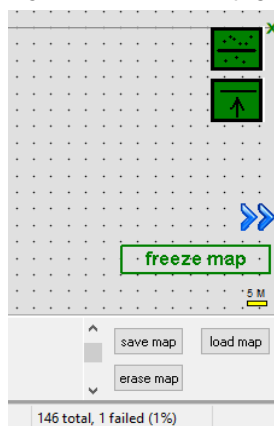

- 4.2.28 Turn on and wake up the mobile beacon following the same steps as with the stationary beacon. More details in our video: https://youtu.be/A4aRsjH2-_E
- 4.2.29 If you see on the devices' panel in the Dashboard that the beacon is colored orange, it means there are some differences in some of the settings between beacons. For example, some sensors may be off or some ultrasonic or radio settings may be different. You can change the settings for sensors manually by clicking on the panel on the upper right corner of the Dashboard to change the cells from gray to green to turn on sensor. It is recommended that the default settings on all beacons and the modem are used if this is your first time using the system.
- 4.2.30 After you freeze the map of stationary beacons, wake up the mobile beacon. After it wakes up, it will be traceable within 5-7 seconds.
- 4.2.31 The system is now fully operational.



4.2.32 In the Dashboard, you can upload a picture/map of your room. You can use a different picture for every floor. Go to [Loading the floorplan](#)
(Help video: <https://www.youtube.com/watch?v=NHUnCtJIYXc>)

The screenshot shows a software interface for managing a floorplan. At the top left, there is a table with data for beacons 22 through 25:

	22	23	24	25
22		10.014	4.975	10.278
23	10.001		11.386	10.422
24	4.880	11.385		6.632
25	10.274	10.424	6.627	

Below the table are controls: 'clear map', 'Dots timeout: 300', 'save screenshot', and 'freeze screen'. The main area is a grid map with several green circular beacons. One beacon is labeled '25' with coordinates: X=2.955, Y=0.998, Z=1.850. Another is labeled '24' with coordinates: X=11.880, Y=0.880, Z=1.850. A third is labeled '23' with coordinates: X=10.000, Y=0.000, Z=1.850. A fourth is labeled '22' with coordinates: X=10.274, Y=4.279, Z=1.850. At the bottom, there is a 'Submap 0' button and a list of devices (beacon 22, beacon 23, beacon 24, beacon 25, device 26, device 27, device 28, device 29, device 30, device 31, device 32, device 33, device 34, device 35). The status bar at the bottom shows 'Connected: COM3 X: 15.742, Y: 9.891' and '1 / 712 total, 3 failed (0%)'. There are also buttons for 'save map', 'load map', and 'erase map'.

4.3 Starter Set NIA-01-3D

The steps below describe the very first time you set up the system. Mini-RX, HW v4.9 beacons and modem required.



Mini-RX has different HW and SW from HW v4.9. Use Mini-RX SW for Mini-RX beacons, HW v4.9's SW for HW v4.9



- 4.3.1 Unpack the system. Look at a similar unpacking video of HW v4.9. The videos have certain differences but the basic are the same: https://youtu.be/sOce7B2_6Sk
- 4.3.2 Charge all the beacons using USB cable. Full charging takes about 1-2 hours
- 4.3.3 Turn the beacons on (To turn Mini-RXs on, carefully disassemble its housing and find DIP switches inside. It is necessary only for the first start. You can also turn it off with switches for long-term storage): Place DIP switches as shown on the picture below

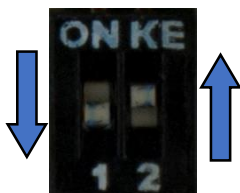

- 4.3.4 Download [SW Pack](#)
- 4.3.5 Update all the beacons:
 - Run the Dashboard and update the SW for all beacons and modem using **Dashboard => Firmware => Choose the file => Program**
 - If you see the message “Not found modem connection to computer through USB” in the Dashboard or your PC does not recognize beacons/modem, it usually means that the STM32 driver is not installed. To install the driver, download it through the link in the top window in the Dashboard and run the installation file, then click on the link under and install the driver

Make sure that that:

- a. You are programming the modem's SW to the modem and the beacon's SW to the beacon



- b. You are using SW for 4.9, if you have HW v4.9; and you have the SW from the same SW pack, i.e., the Dashboard SW, modem SW, and beacon SW must be from the same SW pack. Don't mix SW releases

If SW flashed SUCESSUFLY, MOVE DIRECTLY TO 4.3.6. If you have some problems with HEX programming, use DFU programming:

DFU programming or SW uploading is used when HEX SW uploading in the Dashboard cannot be used. For example, when you are updating from a very old SW version or when the SW includes major changes to the system and the only possible way to update the SW is via DFU programming

- After the DFU SW upgrade, futures SW upgrades can be done in a regular manner via the Dashboard
- To start programming, move the beacon's DIP switch to the DFU programming mode, as described in the paragraph on [DIP switch modes](#) (DIP switch in Mini-RX and Mini-TX situated inside the body. Carefully disassemble the body to access it)
- Download the latest [SW package](#), unzip it, and select the proper version of the SW for your HW and for your frequency variant. Remember that for DFU programming, you should use DFU SW (DfuSe), not Dashboard's .hex file
- Download DfuSe
- Here you will find different versions of DfuSe. v3.0.4 or v3.0.5, whichever works the best for your Windows: [DfuSe v3.0.4](#) or [DfuSe v.3.0.5](#)

DFU Programming:

- Put DIP switch into **Power = ON, DFU = ON** (DIP switch in Mini-RX and Mini-TX situated inside the body. To switch it, carefully disassemble the body)
- Connect the beacon via USB to your PC
- Run DfuSe
- Press the **RESET** button on your beacon
- In the upper left corner of the DfuSe program, you will see a device connected in the DFU mode

- Choose the DFU driver (file) for the beacon

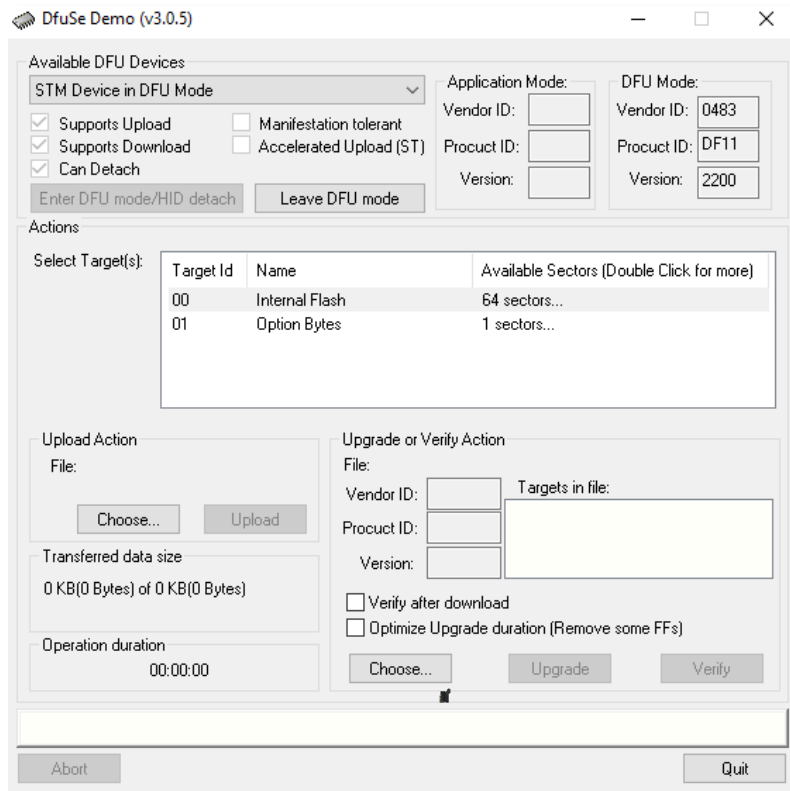

- Click the **UPGRADE** button
- After a couple of seconds, the DFU will be uploaded to the beacon. Make sure it takes 1–3 seconds and does not happen instantly. Otherwise, the SW has not been uploaded correctly. If the DFU appears to upload immediately, check the "Choose" button you used or change the version of DfuSe SW you selected
- Move the DIP switch into **Power = ON, DFU = OFF**
- Start the Dashboard and press the **RESET** button on the beacon
- Check SW on the beacon afterwards
- Everything should be OK with SW now. DFU programming is complete

- Follow the same scenario for the modem:

- Here is the [link](#) for the modem DFU programming. The steps are similar to those for beacon DFU programming
- After uploading DFU driver by DfuSe short circuit pins as shown on the picture (for v4.9) and press **Reset** button

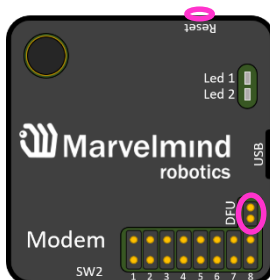

- Modem will go to DFU mode. Press **UPGRADE** button in the DfuSe program
- After a couple of seconds, the DFU will be uploaded to the modem. Make sure it takes 1-3 seconds and does not happen instantly. Otherwise, the SW has not been uploaded correctly. If the DFU appears to upload immediately, check the "Choose" button you used or change the version of DfuSe SW to a different one
- Disconnect the short circuit
- Start the Dashboard and press **RESET** button

If you have uploaded the latest firmware for all the boards, you can start to activate the system:

- 4.3.6 While the beacon or modem is connected to the Dashboard, click the **DEFAULT** button on the Dashboard to upload the default settings

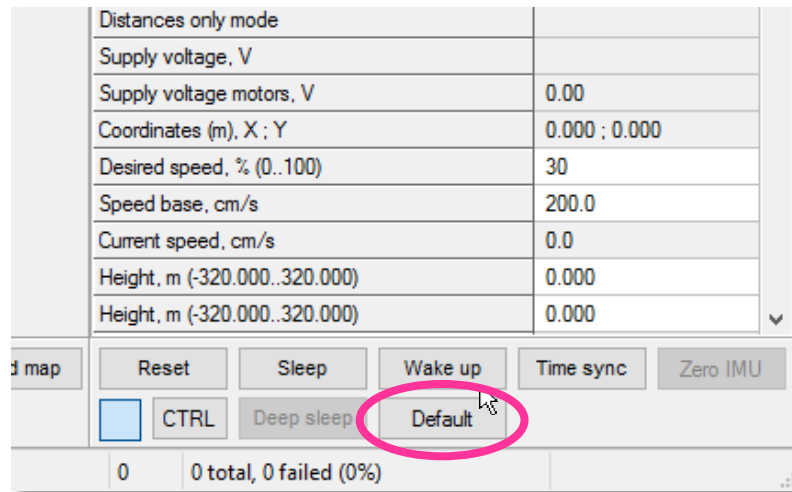

- 4.3.7 Write down the beacon's address for future use or change the address at your convenience as shown here

Meagenog mode	enabled
Inverse system	enabled
Distances only mode	disabled
Supply voltage, V	3.70
Desired speed, % (0..100)	30
Time from reset, h:m:s	00:00:04 R
Measured temperature, °C	23
RSSI, dBm	-74
Radio frequency band	915 MHz
Carrier frequency, MHz	919.000
Device address (0..254)	154
Radio channel	0
Ultrasonic frequency, Hz (100..65000)	n/a
Filter selection	n/a
IMU	(+) expand
Parameters of radio	(+) expand
Ultrasound	(+) expand
Interfaces	(+) expand
Georeferencing	(+) expand
Misc. settings	(+) expand
Hedgehogs pairing	(+) expand
Real-time player	disabled
Real-time player backward (0..127)	3
Real-time player forward (0..127)	5

- 4.3.8 Press the RESET button on your beacons and modem after programming
- 4.3.9 After programming devices with the latest software, the modem and beacons are ready for use
- 4.3.10 Place the stationary beacons high on the walls vertically in a way that will provide optimal ultrasonic coverage. Write down the beacon's height for future change in the settings. The help video on installation can be found here - <https://youtu.be/WY0HkLzmjys>
- 4.3.11 Connect the modem/router via USB to a Windows PC with the Dashboard installed
- 4.3.12 Run the Dashboard. In the left corner of the Dashboard, the modem should be shown as connected
- 4.3.13 Wake up all beacons by selecting them in the Dashboard on the panel
- 4.3.14 It may take up to 7-10 seconds for the beacons to wake up

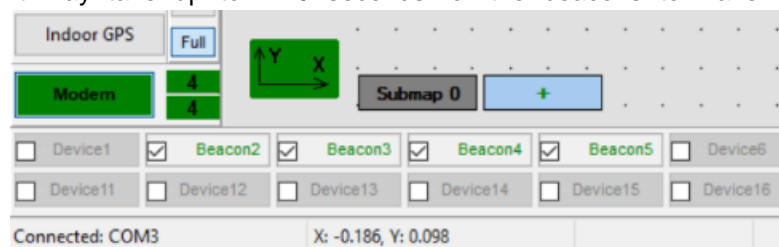

- 4.3.15 Notice, that if the modem is not active and is not powered, the beacons will go into sleep mode automatically after 1 minute

- 4.3.16 The system may run the frequency search, if it is the very first time you are waking up the beacons. If this step does not work, disconnect the modem and connect that beacon again via USB. Press the DEFAULT button in the Dashboard and the Read All button to make sure that the radio settings are the default ones
- 4.3.17 Check that the radio settings on the modem and the radio settings on the beacon are the same
- 4.3.18 Now you can check RSSI, voltage, ultrasonic filter settings, etc. on the panel on the right corner of the Dashboard

Supply voltage, V	3.95
Desired speed, % (0..100)	30
Height, m (-320.000..320.000)	0.000
Time from reset, h:m:s	00:01:26 R
Measured temperature, °C	23
RSSI, dBm	-28
Radio frequency band	915 MHz
Carrier frequency, MHz	919.000
Device address (0..254)	30
Radio channel	0
Ultrasonic frequency, Hz (100..65000)	25000
Filter selection	31 kHz

- 4.3.19 Enter the height of stationary beacons. Choose beacon in the list and enter height value

Read all		Write all	
CPU ID	Copy to clipboard	013326	
Firmware version	V6.192 Super-Beacon		
Power save functions	enabled		
Hedgehog mode	enabled		
Inverse system	disabled		
Distances only mode	disabled		
Supply voltage, V	3.95		
Desired speed, % (0..100)	30		
Height, m (-320.000..320.000)	0.000		
Time from reset, h:m:s	00:01:26 R		
Measured temperature, °C	23		
RSSI, dBm	-28		
Radio frequency band	915 MHz		
Carrier frequency, MHz	919.000		
Device address (0..254)	30		
Radio channel	0		
Ultrasonic frequency, Hz (100..65000)	25000		
Filter selection	31 kHz		



- 4.3.20 Enter the height for mobile beacon if you use 2D mode

- 4.3.21 In the current version one modem supports 250 beacons (mobile + stationary combined). If you do not see some of your connected beacons on the map, you may need to scroll to find their addresses

- 4.3.22 Double click on the device to put it into sleep mode or wake it up



Only 4 stationary beacons may be in 1 submap. If you wake up more beacons, create a new submap for them, otherwise it will not be displayed on the map and in the table of distances.

- 4.3.23 Build the map:

Mini-RX beacons cannot build the map automatically, manual inputting of the coordinates is required

Step 1. Open the Dashboard. You will see the table of distances

Step 2. Use right mouse click on cell you want to enter the distance. Additional menu will open. There you can

control the table of distances. Choose **Enter distance for pair** to enter the value

HIDE	5	22	66	77
5		7.144	12.300	10.101
22	7.144		10.1	
66	12.389	10.122		
77	10.101	12.151	6.8	

Freeze distance for pair

Freeze average for pair

Don't use distance

Freeze all

Unfreeze all

Enter distance for pair

Clear cell

Step 3. Now, enter measured (measure it with laser distance meter or so) value. That values would not change until you unfreeze or clear it. Even if beacons had been moved, distance would stay. Be careful with frozen cells because a small mistake can cause a significant impact on your tracking

Step 4. Repeat for all cells

HIDE	6	22	66	77
6		8.000	4.200	11.400
22	8.000		13.100	6.500
66	4.200	13.100		10.800
77	11.400	6.500	10.800	

4.3.24 Make a service zone, clicking on the map with **Shift+Left Mouse Button**. See [Submaps chapter](#) for more details

4.3.25 Freeze the map by clicking the button. Stationary beacons will stop measuring relative distances and will be ready to measure distance from the mobile beacon(s)

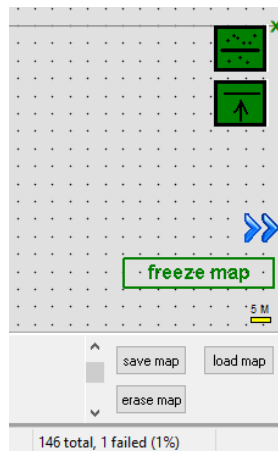

4.3.26 Turn on and wake up the mobile beacon following the same steps as with the stationary beacon: <https://youtu.be/A4aRsjH2-E>

4.3.27 If you see on the devices' panel in the Dashboard that the beacon is colored orange, it means there are some differences in some of the settings between beacons. For example, some sensors may be off



or some ultrasonic or radio settings may be different. You can change the settings for sensors manually by clicking on the panel on the upper right corner of the Dashboard to change the cells from gray to green to turn on sensor. It is recommended that the default settings on all beacons and the modem be used if this is your first time using the system.

4.3.28 After you freeze the map of stationary beacons, wake up the mobile beacon. After it wakes up, it will be traceable in 5-7 seconds.

4.3.29 The system is now fully operational.

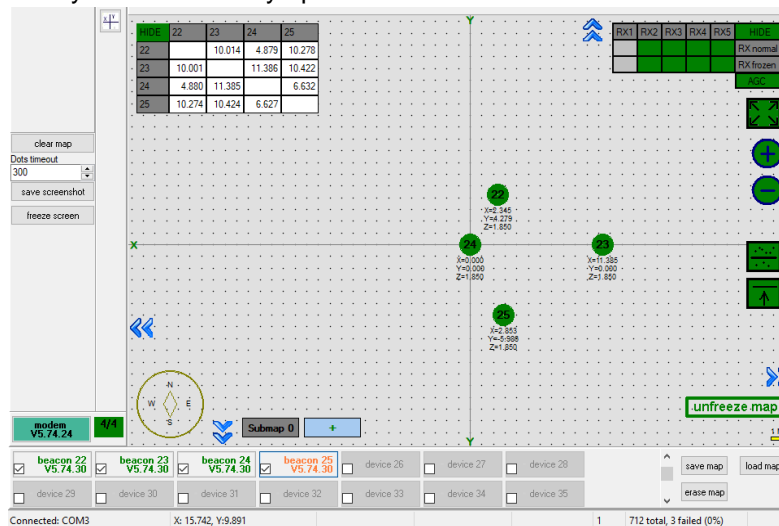

4.4 Starter Set NIA-SmallDrone

The steps below describe the very first time you set up the system. Mini-RX, Mini-TX beacons and modem required.



Mini-RX and Mini-TX have different HW and SW from HW v4.9. Use Mini-RX SW for Mini-RX beacons, Mini-TX SW for Mini-TX beacons, HW v4.9's SW for HW v4.9



- 4.4.1 Unpack the system. Take a look at a similar unpacking video of HW v4.9. The videos have certain differences but the basic are the same: https://youtu.be/sOce7B2_6Sk
- 4.4.2 Charge all the beacons using USB cable. Full charging takes about 1-2 hours
- 4.4.3 Turn the beacons on (To turn Mini-RXs on, carefully disassemble its housing and find DIP switches inside. It is necessary only for the first start. You can also turn it off with switches for long-term storage): Place DIP switches as shown on the picture below

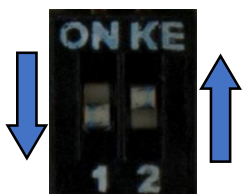

- 4.4.4 Download [SW Pack](#)
- 4.4.5 Update all the beacons:
 - Run the Dashboard and update the SW for all beacons and modem using **Dashboard => Firmware => Choose the file =>**

Program

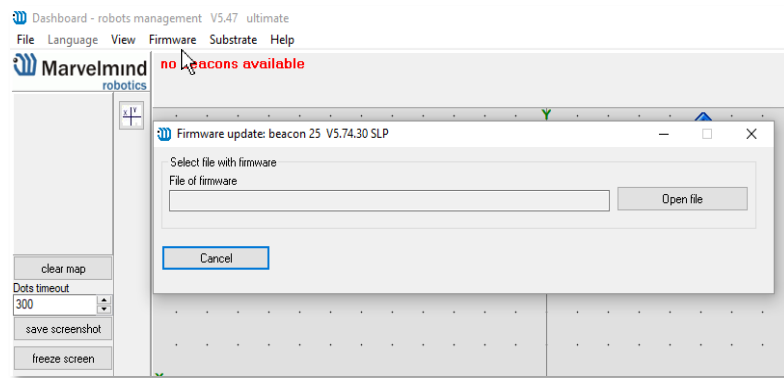

- If you see the message “Not found modem connection to computer through USB” in the Dashboard or your PC does not recognize beacons/modem, it usually means that the STM32 driver is not installed. To install the driver, download it through the link in the top window in the Dashboard and run the installation file, then click on the link under and install the driver

Make sure that that:

c. You are programming the modem's SW to the modem and the beacon's SW to the beacon



d. You are using SW for Mini-TX, if you have Mini-TX; and you have the SW from the same SW pack, i.e., the Dashboard SW, modem SW, and beacon SW must be from the same SW pack. Don't mix SW releases

If SW flashed SUCCESSFULLY, MOVE DIRECTLY TO 4.4.6. If you have some problems with HEX programming, use DFU programming:

DFU programming or SW uploading is used when HEX SW uploading in the Dashboard cannot be used. For example, when you are updating from a very old SW version or when the SW includes major changes to the system and the only possible way to update the SW is via DFU programming

- After the DFU SW upgrade, future SW upgrades can be done in a regular manner via the Dashboard
- To start programming, move the beacon's DIP switch to the DFU programming mode, as described in the paragraph on [DIP switch modes](#) (DIP switch in Mini-RX and Mini-TX situated inside the body. Carefully disassemble the body to access it)
- Download the latest [SW package](#), unzip it, and select the proper version of the SW for your HW and for your frequency variant. Remember that for DFU programming, you should use DFU SW (DfuSe), not Dashboard's .hex file
- Download DfuSe
- Here you will find different versions of DfuSe. v3.0.4 or v3.0.5, whichever works the best for your Windows: [DfuSe v3.0.4](#) or [DfuSe v.3.0.5](#)

DFU Programming:

- Put DIP switch into **Power = ON, DFU = ON** (DIP switch in Mini-RX and Mini-TX situated inside the body. To switch it, carefully disassemble the body)
- Connect the beacon via USB to your PC
- Run DfuSe
- Press the **RESET** button on your beacon
- In the upper left corner of the DfuSe program, you will see a device connected in the DFU mode
- Choose the DFU driver (file) for the beacon

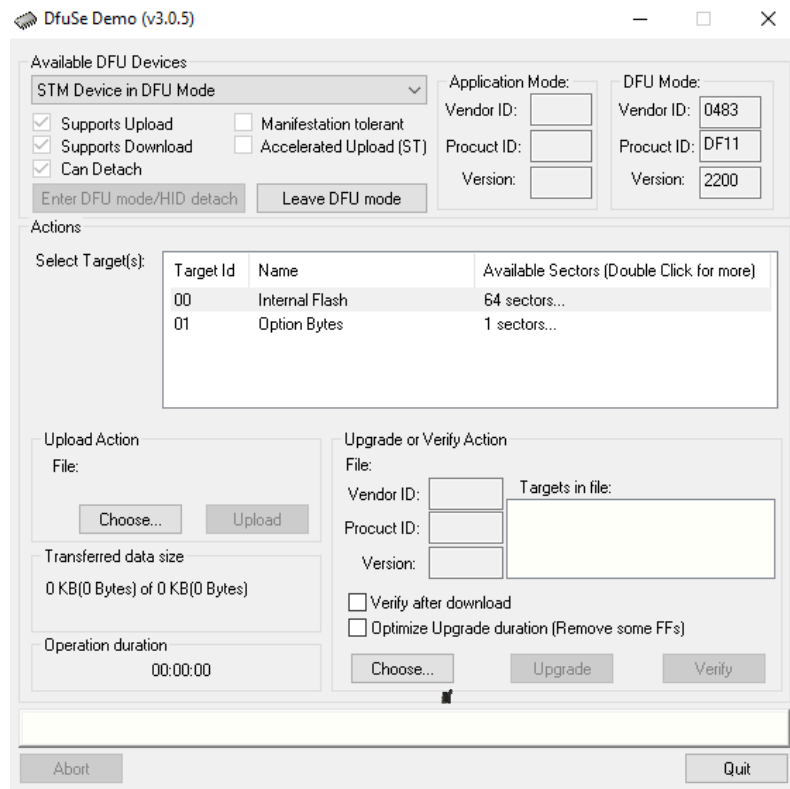

- Click the **UPGRADE** button
- After a couple of seconds, the DFU will be uploaded to the beacon. Make sure it takes 1–3 seconds and does not happen instantly. Otherwise, the SW has not been uploaded correctly. If the DFU appears to upload immediately, check the "Choose" button you used or change the version of DfuSe SW you selected
- Move the DIP switch into **Power = ON, DFU = OFF**
- Start the Dashboard and press the **RESET** button on the beacon
- Check SW on the beacon afterwards
- Everything should be OK with SW now. DFU programming is complete
- Follow the same scenario for the modem:
 - Here is the [link](#) for the modem DFU programming. The steps are similar to those for beacon DFU programming



- After uploading DFU driver by DfuSe short circuit pins as shown on the picture (for v4.9) and press **Reset** button

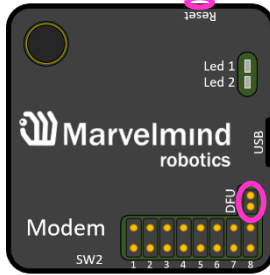

- Modem will go to DFU mode. Press **UPGRADE** button in the DfuSe program
- After a couple of seconds, the DFU will be uploaded to the modem. Make sure it takes 1-3 seconds and does not happen instantly. Otherwise, the SW has not been uploaded correctly. If the DFU appears to upload immediately, check the "Choose" button you used or change the version of DfuSe SW to a different one
- Disconnect the short circuit
- Start the Dashboard and press **RESET** button

If you have uploaded the latest firmware for all of the boards, you can start to activate the system:

- 4.4.6 While the beacon or modem is connected to the Dashboard, click the **DEFAULT** button on the Dashboard to upload the default settings

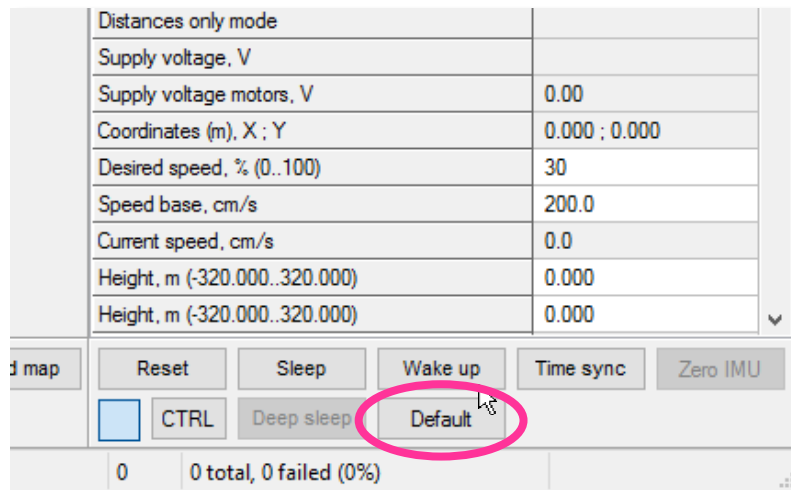

- 4.4.7 Write down the beacon's address for future use or change the address at your convenience as shown here

hedgenog mode	enabled
Inverse system	enabled
Distances only mode	disabled
Supply voltage, V	3.70
Desired speed, % (0..100)	30
Time from reset, h:m:s	00:00:04 R
Measured temperature, °C	23
RSSI, dBm	-74
Radio frequency band	915 MHz
Carrier frequency, MHz	919.000
Device address (0..254)	154
Radio channel	0
Ultrasonic frequency, Hz (100..65000)	n/a
Filter selection	n/a
IMU	(+) expand
Parameters of radio	(+) expand
Ultrasound	(+) expand
Interfaces	(+) expand
Georeferencing	(+) expand
Misc. settings	(+) expand
Hedgehogs pairing	(+) expand
Real-time player	disabled
Real-time player backward (0..127)	3
Real-time player forward (0..127)	5

- 4.4.8 Press the RESET button on your beacons and modem after programming
- 4.4.9 After programming devices with the latest software, the modem and beacons are ready for use
- 4.4.10 Place the stationary beacons high on the walls vertically in a way that will provide optimal ultrasonic coverage. Write down the beacon's height for future change in the settings. The help video on installation can be found here - <https://youtu.be/WYOHkLzmjys>
- 4.4.11 Connect the modem/router via USB to a Windows PC with the Dashboard installed
- 4.4.12 Run the Dashboard. In the left corner of the Dashboard, the modem should be shown as connected
- 4.4.13 Wake up all beacons by selecting them in the Dashboard on the panel
- 4.4.14 It may take up to 7-10 seconds for the beacons to wake up

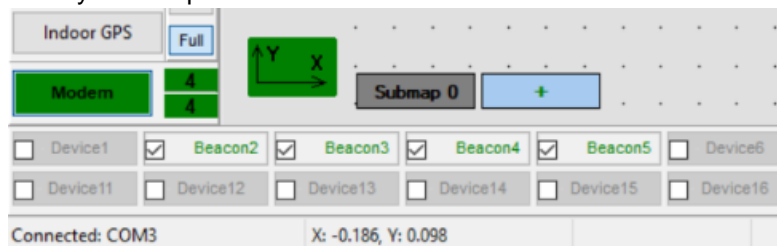

- 4.4.15 Notice, that if the modem is not active and is not powered, the beacons will go into sleep mode automatically after 1 minute
- 4.4.16 The system may run the frequency search, if it is the very first time you are waking up the beacons. If this step does not work, disconnect the modem and connect that beacon again via USB. Press the DEFAULT button in the Dashboard and the Read All button to make sure that the radio settings are the default ones
- 4.4.17 Check that the radio settings on the modem and the radio settings on the beacon are the same
- 4.4.18 Now you can check RSSI, voltage, ultrasonic filter settings, etc. on the panel on the right corner of the Dashboard

Supply voltage, V	3.95
Desired speed, % (0..100)	30
Height, m (-320.000..320.000)	0.000
Time from reset, h:m:s	00:01:26 R
Measured temperature, °C	23
RSSI, dBm	-28
Radio frequency band	915 MHz
Carrier frequency, MHz	919.000
Device address (0..254)	30
Radio channel	0
Ultrasonic frequency, Hz (100..65000)	25000
Filter selection	31 kHz

- 4.4.19 Enter the height of stationary beacons. Choose beacon in the list and enter height value

Read all		Write all
CPU ID	Copy to clipboard	013326
Firmware version		V6.192 Super-Beacon
Power save functions		enabled
Hedgehog mode		enabled
Inverse system		disabled
Distances only mode		disabled
Supply voltage, V		3.95
Desired speed, % (0..100)		30
Height, m (-320.000..320.000)		0.000
Time from reset, h:m:s		00:01:26 R
Measured temperature, °C		23
RSSI, dBm		-28
Radio frequency band		915 MHz
Carrier frequency, MHz		919.000
Device address (0..254)		30
Radio channel		0
Ultrasonic frequency, Hz (100..65000)		25000
Filter selection		31 kHz



- 4.4.20 Enter the height for mobile beacon if you use 2D mode
- 4.4.21 In the current version one modem supports 250 beacons (mobile + stationary combined). If you do not see some of your connected beacons on the map, you may need to scroll to find their addresses
- 4.4.22 Double click on the device to put it into sleep mode or wake it up



Only 4 stationary beacons may be in 1 submap. If you wake up more beacons, create a new submap for them, otherwise it will not be displayed on the map and in the table of distances.

- 4.4.23 Build the map:

Mini-RX beacons cannot build the map automatically, manual inputting of the coordinates is required

Step 5. Open the Dashboard. You will see the table of distances

Step 6. Use right mouse click on cell you want to enter the distance. Additional menu will open. There you can control the table of distances. Choose **Enter distance for pair** to enter the value

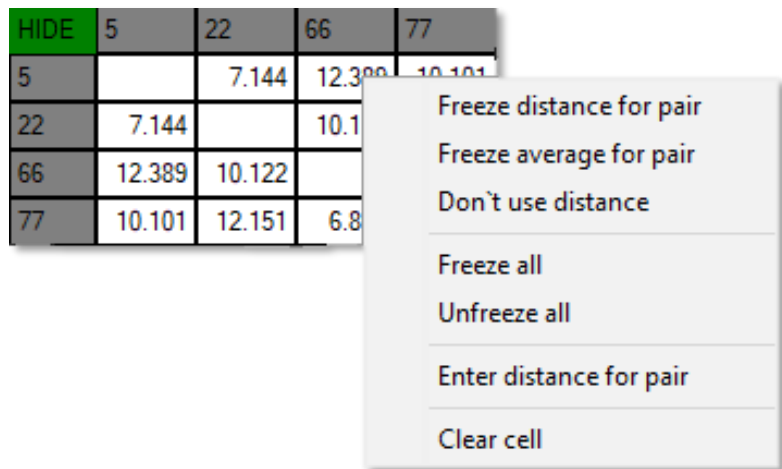

Step 7. Now, enter measured (measure it with laser distance meter or so) value. That values would not change until you unfreeze or clear it. Even if beacons had been moved, distance would stay. Be careful with frozen cells because a small mistake can cause a significant impact on your tracking

Step 8. Repeat for all cells

HIDE	6	22	66	77
6		8.000	4.200	11.400
22	8.000		13.100	6.500
66	4.200	13.100		10.800
77	11.400	6.500	10.800	

4.4.24 Freeze the map by clicking the button. Stationary beacons will stop measuring relative distances and will be ready to measure distance from the mobile beacon(s)

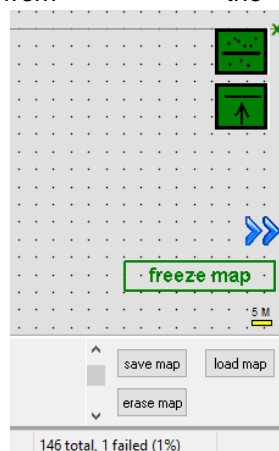

4.4.25 Turn on and wake up the mobile beacon following the same steps as with the stationary beacon: <https://youtu.be/A4aRsjH2-E>

4.4.26 If you see on the devices' panel in the Dashboard that the beacon is colored orange, it means there are some differences in some of the



settings between beacons. For example, some sensors may be off or some ultrasonic or radio settings may be different. You can change the settings for sensors manually by clicking on the panel on the upper right corner of the Dashboard to change the cells from gray to green to turn on sensor. It is recommended that the default settings on all beacons and the modem be used if this is your first time using the system.

4.4.27 After you freeze the map of stationary beacons, wake up the mobile beacon. After it wakes up, it will be traceable in 5-7 seconds.

4.4.28 The system is now fully operational.

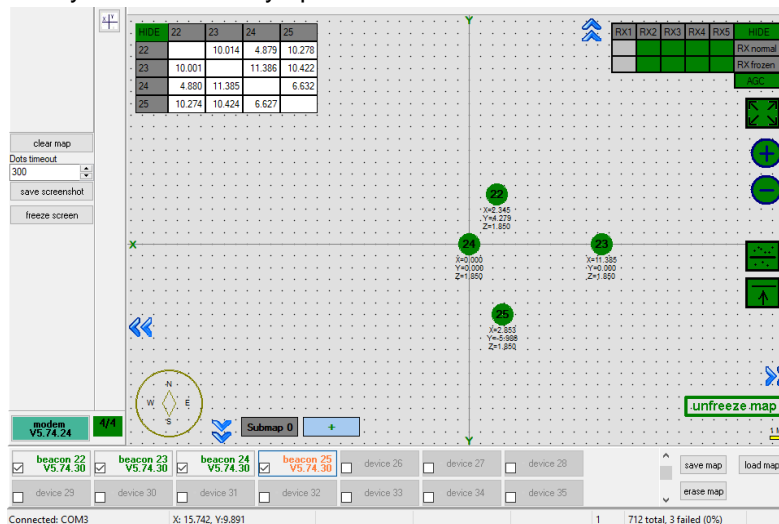

4.5 Starter Set NIA-02-2D

The steps below describe the very first time you set up the system. Mini-RX, Mini-TX beacons and modem required.



Mini-RX and Mini-TX have different HW and SW from HW v4.9. Use Mini-RX SW for Mini-RX beacons, Mini-TX SW for Mini-TX beacons, HW v4.9's SW for HW v4.9



- 4.5.1 Unpack the system. Take a look at a similar unpacking video of HW v4.9. The videos have certain differences but the basic are the same: https://youtu.be/sOce7B2_6Sk
- 4.5.2 Charge all the beacons using USB cable. Full charging takes about 1-2 hours
- 4.5.3 Turn the beacons on (To turn Mini-RXs on, carefully disassemble its housing and find DIP switches inside. It is necessary only for the first start. You can also turn it off with switches for long-term storage): Place DIP switches as shown on the picture below

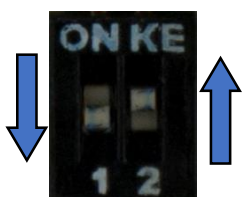

- 4.5.4 Download [SW Pack](#)
- 4.5.5 Update all the beacons:
 - Run the Dashboard and update the SW for all beacons and modem using **Dashboard => Firmware => Choose the file =>**

Program

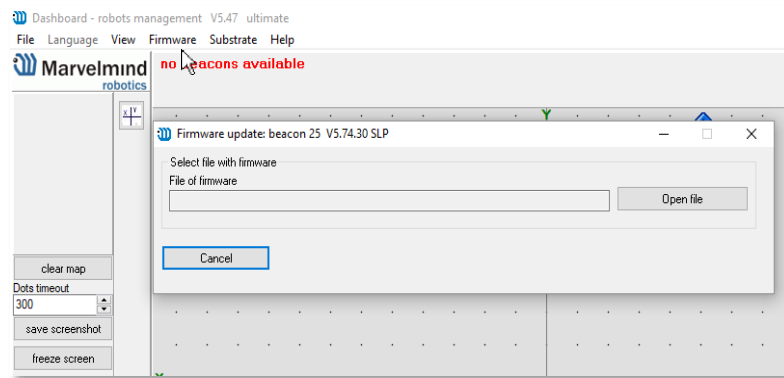

- If you see the message “Not found modem connection to computer through USB” in the Dashboard or your PC does not recognize beacons/modem, it usually means that the STM32 driver is not installed. To install the driver, download it through the link in the top window in the Dashboard and run the installation file, then click on the link under and install the driver

Make sure that that:

e. You are programming the modem's SW to the modem and the beacon's SW to the beacon



f. You are using SW for Mini-TX, if you have Mini-TX; and you have the SW from the same SW pack, i.e., the Dashboard SW, modem SW, and beacon SW must be from the same SW pack. Don't mix SW releases

If SW flashed SUCCESSFULLY, MOVE DIRECTLY TO 4.5.6. If you have some problems with HEX programming, use DFU programming:

DFU programming or SW uploading is used when HEX SW uploading in the Dashboard cannot be used. For example, when you are updating from a very old SW version or when the SW includes major changes to the system and the only possible way to update the SW is via DFU programming

- After the DFU SW upgrade, future SW upgrades can be done in a regular manner via the Dashboard
- To start programming, move the beacon's DIP switch to the DFU programming mode, as described in the paragraph on [DIP switch modes](#) (DIP switch in Mini-RX and Mini-TX situated inside the body. Carefully disassemble the body to access it)
- Download the latest [SW package](#), unzip it, and select the proper version of the SW for your HW and for your frequency variant. Remember that for DFU programming, you should use DFU SW (DfuSe), not Dashboard's .hex file
- Download DfuSe
- Here you will find different versions of DfuSe. v3.0.4 or v3.0.5, whichever works the best for your Windows: [DfuSe v3.0.4](#) or [DfuSe v.3.0.5](#)

DFU Programming:



- Put DIP switch into **Power = ON, DFU = ON** (DIP switch in Mini-RX and Mini-TX situated inside the body. To switch it, carefully disassemble the body)
- Connect the beacon via USB to your PC
- Run DfuSe
- Press the **RESET** button on your beacon
- In the upper left corner of the DfuSe program, you will see a device connected in the DFU mode
- Choose the DFU driver (file) for the beacon

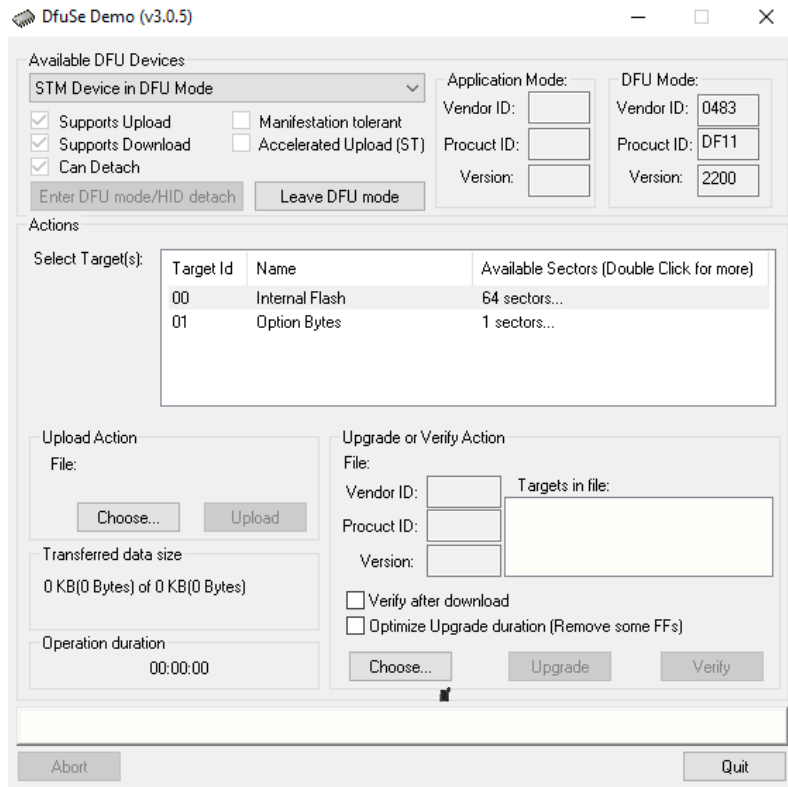

- Click the **UPGRADE** button
- After a couple of seconds, the DFU will be uploaded to the beacon. Make sure it takes 1–3 seconds and does not happen instantly. Otherwise, the SW has not been uploaded correctly. If the DFU appears to upload immediately, check the "Choose" button you used or change the version of DfuSe SW you selected
- Move the DIP switch into **Power = ON, DFU = OFF**
- Start the Dashboard and press the **RESET** button on the beacon
- Check SW on the beacon afterwards
- Everything should be OK with SW now. DFU programming is complete
- Follow the same scenario for the modem:
 - Here is the [link](#) for the modem DFU programming. The steps are similar to those for beacon DFU programming



- After uploading DFU driver by DfuSe short circuit pins as shown on the picture (for v4.9) and press **Reset** button

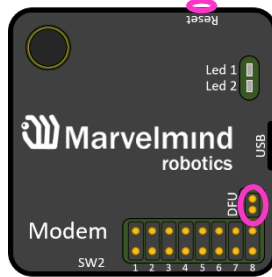

- Modem will go to DFU mode. Press **UPGRADE** button in the DfuSe program
- After a couple of seconds, the DFU will be uploaded to the modem. Make sure it takes 1-3 seconds and does not happen instantly. Otherwise, the SW has not been uploaded correctly. If the DFU appears to upload immediately, check the "Choose" button you used or change the version of DfuSe SW to a different one
- Disconnect the short circuit
- Start the Dashboard and press **RESET** button

If you have uploaded the latest firmware for all of the boards, you can start to activate the system:

- 4.5.6 While the beacon or modem is connected to the Dashboard, click the **DEFAULT** button on the Dashboard to upload the default settings

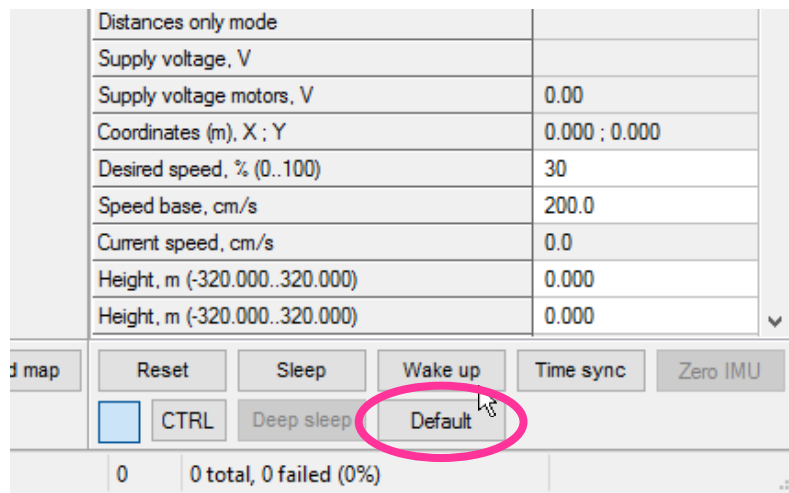

4.5.7 Write down the beacon's address for future use or change the address at your convenience as shown here

Reegenog mode	enabled
Inverse system	enabled
Distances only mode	disabled
Supply voltage, V	3.70
Desired speed, % (0..100)	30
Time from reset, h:m:s	00:00:04 R
Measured temperature, °C	23
RSSI, dBm	-74
Radio frequency band	915 MHz
Carrier frequency, MHz	919.000
Device address (0..254)	154
Radio channel	0
Ultrasonic frequency, Hz (100..65000)	n/a
Filter selection	n/a
IMU	(+) expand
Parameters of radio	(+) expand
Ultrasound	(+) expand
Interfaces	(+) expand
Georeferencing	(+) expand
Misc. settings	(+) expand
Hedgehogs pairing	(+) expand
Real-time player	disabled
Real-time player backward (0..127)	3
Real-time player forward (0..127)	5

4.5.8 Press the RESET button on your beacons and modem after programming

4.5.9 After programming devices with the latest software, the modem and beacons are ready for use

4.5.10 Place the stationary beacons high on the walls vertically in a way that will provide optimal ultrasonic coverage. Write down the beacon's height for future change in the settings. The help video on installation can be found here - <https://youtu.be/WYOHkLzmijs>

4.5.11 Connect the modem/router via USB to a Windows PC with the Dashboard installed

4.5.12 Run the Dashboard. In the left corner of the Dashboard, the modem should be shown as connected

4.5.13 Wake up all beacons by selecting them in the Dashboard on the panel

4.5.14 It may take up to 7-10 seconds for the beacons to wake up

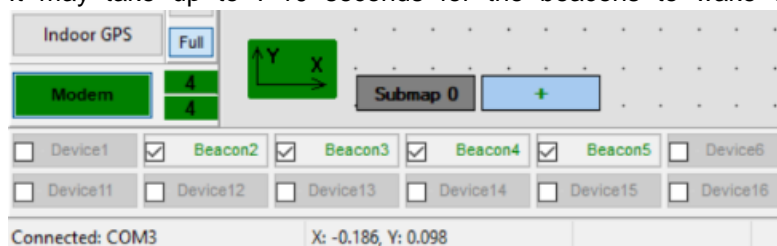

- 4.5.15 Notice, that if the modem is not active and is not powered, the beacons will go into sleep mode automatically after 1 minute
- 4.5.16 The system may run the frequency search, if it is the very first time you are waking up the beacons. If this step does not work, disconnect the modem and connect that beacon again via USB. Press the DEFAULT button in the Dashboard and the Read All button to make sure that the radio settings are the default ones
- 4.5.17 Check that the radio settings on the modem and the radio settings on the beacon are the same
- 4.5.18 Now you can check RSSI, voltage, ultrasonic filter settings, etc. on the panel on the right corner of the Dashboard

Supply voltage, V	3.95
Desired speed, % (0..100)	30
Height, m (-320.000..320.000)	0.000
Time from reset, h:m:s	00:01:26 R
Measured temperature, °C	23
RSSI, dBm	-28
Radio frequency band	915 MHz
Carrier frequency, MHz	919.000
Device address (0..254)	30
Radio channel	0
Ultrasonic frequency, Hz (100..65000)	25000
Filter selection	31 kHz

- 4.5.19 Enter the height of stationary beacons. Choose beacon in the list and enter height value

Read all		Write all
CPU ID	Copy to clipboard	013326
Firmware version		V6.192 Super-Beacon
Power save functions		enabled
Hedgehog mode		enabled
Inverse system		disabled
Distances only mode		disabled
Supply voltage, V		3.95
Desired speed, % (0..100)		30
Height, m (-320.000..320.000)		0.000
Time from reset, h:m:s		00:01:26 R
Measured temperature, °C		23
RSSI, dBm		-28
Radio frequency band		915 MHz
Carrier frequency, MHz		919.000
Device address (0..254)		30
Radio channel		0
Ultrasonic frequency, Hz (100..65000)		25000
Filter selection		31 kHz



- 4.5.20 Enter the height for mobile beacon if you use 2D mode
- 4.5.21 In the current version one modem supports 250 beacons (mobile + stationary combined). If you do not see some of your connected beacons on the map, you may need to scroll to find their addresses
- 4.5.22 Double click on the device to put it into sleep mode or wake it up



Only 4 stationary beacons may be in 1 submap. If you wake up more beacons, create a new submap for them, otherwise it will not be displayed on the map and in the table of distances.

- 4.5.23 Build the map:

Mini-RX beacons cannot build the map automatically, manual inputting of the coordinates is required

Step 9. Open the Dashboard. You will see the table of distances

Step 10. Use right mouse click on cell you want to enter the distance. Additional menu will open. There you can control the table of distances. Choose **Enter distance for pair** to enter the value

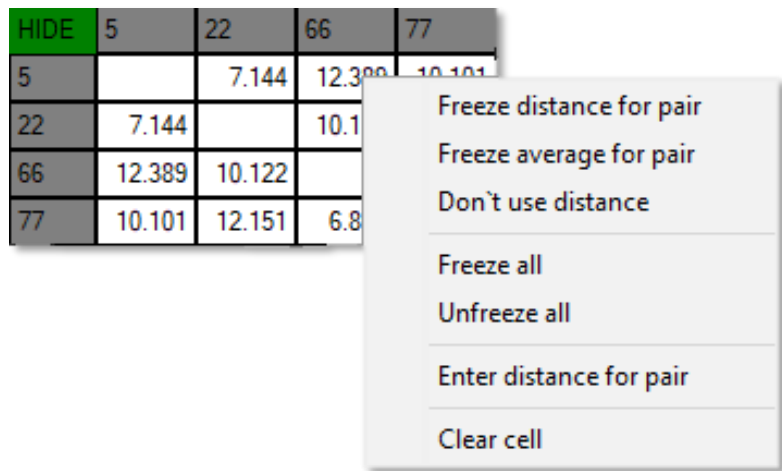

Step 11. Now, enter measured (measure it with laser distance meter or so) value. That values would not change until you unfreeze or clear it. Even if beacons had been moved, distance would stay. Be careful with frozen cells because a small mistake can cause a significant impact on your tracking

Step 12. Repeat for all cells

HIDE	6	22	66	77
6		8.000	4.200	11.400
22	8.000		13.100	6.500
66	4.200	13.100		10.800
77	11.400	6.500	10.800	

4.5.24 Freeze the map by clicking the button. Stationary beacons will stop measuring relative distances and will be ready to measure distance from the mobile beacon(s)

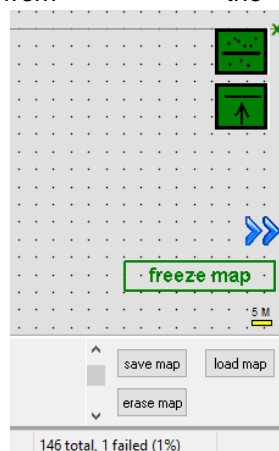

4.5.25 Turn on and wake up the mobile beacon following the same steps as with the stationary beacon: https://youtu.be/A4aRsJH2-_E

4.5.26 If you see on the devices' panel in the Dashboard that the beacon is colored orange, it means there are some differences in some of the

settings between beacons. For example, some sensors may be off or some ultrasonic or radio settings may be different. You can change the settings for sensors manually by clicking on the panel on the upper right corner of the Dashboard to change the cells from gray to green to turn on sensor. It is recommended that the default settings on all beacons and the modem be used if this is your first time using the system.

4.5.27 After you freeze the map of stationary beacons, wake up the mobile beacon. After it wakes up, it will be traceable in 5-7 seconds.

4.5.28 The system is now fully operational.

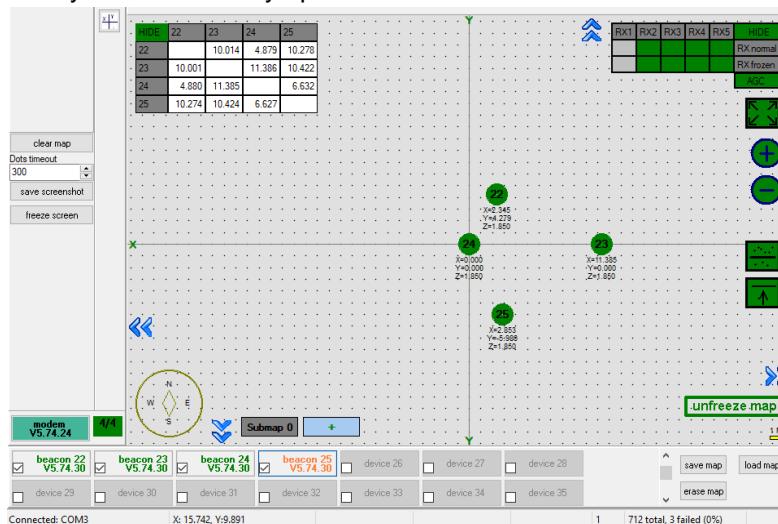

4.6 Starter Set Industrial-NIA-01

The steps below describe the first set up of the system.



This is a Non-Inverse Architecture. You can find the description and comparison of architectures [here](#).



Pay attention: Industrial beacons have different HW and SW from HW v4.9. It has different connectors, reset and DFU activation. Read more on [Industrial beacon page](#).

Industrial beacons have no battery, use power supply cable.

Use Industrial beacon's SW for Industrial beacons, v4.9 for v4.9.



4.6.1 Unpack the system. Take a look at the similar unpacking video of HW v4.9. They are different, but have some similar basics: https://youtu.be/sOce7B2_6Sk

4.6.2 You do not have to charge Industrial beacons; they have no battery

4.6.3 You do not have to turn it on - **Industrial beacons are permanently ON**



4.6.4 Download [SW Pack](#)

4.6.5 Update all the beacons:

- Run the Dashboard and update the SW for all beacons and modem using **Dashboard => Firmware => Choose the file => Program**

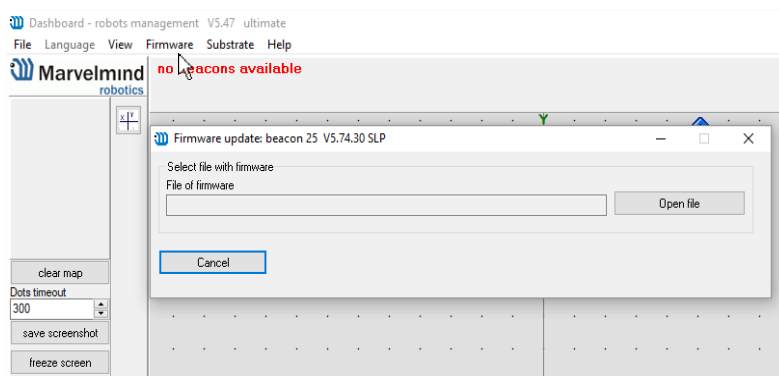

- If you see the message “Not found modem connection to computer through USB” in the Dashboard or your PC does not recognize beacons/modem, it usually means that the STM32 driver is not installed. To install the driver, download it with link

at top window in the Dashboard and run the installation file, then click on the link under and install the driver

Ensure that:

- (e) You are programming the modem's SW to the modem and the beacon's SW to the beacon
- (f) You are using SW for 4.9, if you have HW v4.9; and you have the SW from the same SW pack, i.e., the Dashboard SW, modem SW, and beacon SW must be from the same SW pack. Don't mix SW releases



If SW flashed SUCESFULLY, MOVE DIRECTLY TO 4.6.6. If you have some problems with HEX programming, use DFU programming:

DFU programming or SW uploading is used when HEX SW uploading in the Dashboard cannot be used. For example, when you are updating from a very old SW version or when the SW includes major changes to the system and the only possible way to update the SW is via DFU programming

- After the DFU SW upgrade, futures SW upgrades can be done in a regular manner via the Dashboard
- Industrial beacons have magnetic DFU mode and reset
- Download the latest [SW package](#), unzip it, and select the proper version of the SW for your HW and for your frequency variant. Remember that for DFU programming, you should use DFU SW (DfuSe), not Dashboard's .hex file
- Download DfuSe
- Here you will find different versions of DfuSe. v3.0.4 or v3.0.5, whichever works the best for your Windows: [DfuSe v3.0.4](#) or [DfuSe v.3.0.5](#)

DFU Programming:



Uploading Beacon Industrial's (Not super) DFU software to Industrial Super-Beacon hardware make permanently damage for Industrial Super-Beacon board. Be double attentive with update

- Activate DFU mode and reset the beacon (Industrial beacons have magnetic DFU mode and reset). Place first magnet (**any strong and modern magnet**) to the right side of the beacon (Step 1). After that, place second magnet to the left side of the beacon and remove it in a second, just to reset it (Step 2)

Step 1: DFU mode



Step 2: Reset

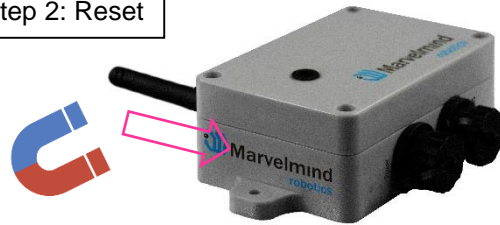

Magnet examples



- Connect the beacon via USB to your PC
- Connect power supply cable to your beacon
- Run DfuSe
- In the upper left corner of the DfuSe program, you will see a device connected in the DFU mode
- Choose the DFU driver (file) for the beacon

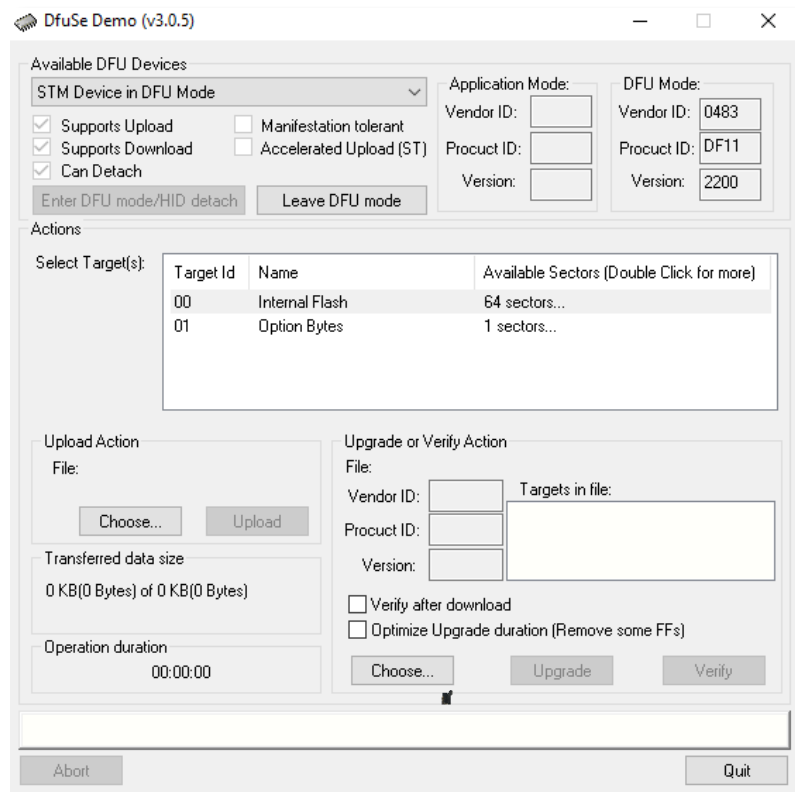

- Click the **UPGRADE** button
- After a couple of seconds, the DFU will be uploaded to the beacon. Make sure it takes 1–3 seconds and does not happen instantly. Otherwise, the SW has not been uploaded correctly. If the DFU appears to upload

immediately, check the "Choose" button you used or change the version of DfuSe SW you selected

- Start the Dashboard
- Reset the beacon again
- Check SW on the beacon afterwards
- Everything should be OK with SW now. DFU programming is complete.

DFU Programming for the modem:

- Here is the [link](#) for the modem DFU programming. The steps are similar to those for beacon DFU programming.
- After uploading DFU driver by DfuSe short circuit pins as shown on the picture (for v4.9) and press **Reset** button

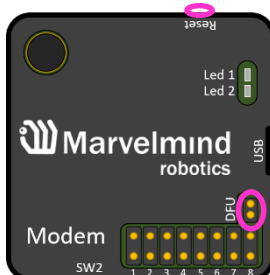

- Modem will go to DFU mode. Press **UPGRADE** button in the DfuSe program
- After a couple of seconds, the DFU will be uploaded to the modem. Make sure it takes 1-3 seconds and does not happen instantly. Otherwise, the SW has not been uploaded correctly. If the DFU appears to upload immediately, check the "Choose" button you used or change the version of DfuSe SW to a different one.
- Disconnect the short circuit.
- Start the Dashboard and press **RESET** button.

If you have uploaded the latest firmware for all the boards, you can start to activate the system:

- 4.6.6 While the beacon or modem is connected to the Dashboard, click the **DEFAULT** button on the Dashboard to upload the default

settings

Distances only mode	
Supply voltage, V	
Supply voltage motors, V	0.00
Coordinates (m), X : Y	0.000 ; 0.000
Desired speed, % (0..100)	30
Speed base, cm/s	200.0
Current speed, cm/s	0.0
Height, m (-320.000..320.000)	0.000
Height, m (-320.000..320.000)	0.000

<input type="button" value="Reset"/> <input type="button" value="Sleep"/> <input type="button" value="Wake up"/> <input type="button" value="Time sync"/> <input type="button" value="Zero IMU"/>
<input type="checkbox"/> CTRL <input type="button" value="Deep sleep"/> <input type="button" value="Default"/>
0 0 total, 0 failed (0%)

- 4.6.7 Write down the beacon's address for future use or change the address at your convenience as shown here

beaconog mode	enabled
Inverse system	enabled
Distances only mode	disabled
Supply voltage, V	3.70
Desired speed, % (0..100)	30
Time from reset, h:m:s	00:00:04 R
Measured temperature, °C	23
RSSI, dBm	-74
Radio frequency band	915 MHz
Carrier frequency, MHz	910.000
Device address (0..254)	154
Radio channel	0
Ultrasonic frequency, Hz (100..65000)	n/a
Filter selection	n/a
IMU	(+) expand
Parameters of radio	(+) expand
Ultrasound	(+) expand
Interfaces	(+) expand
Georeferencing	(+) expand
Misc. settings	(+) expand
Hedgehogs pairing	(+) expand
Real-time player	disabled
Real-time player backward (0..127)	3
Real-time player forward (0..127)	5

- 4.6.8 Press the RESET (Industrial beacons have magnetic re button on your beacons and modem after programming
- 4.6.9 After programming devices with the latest software, the modem and beacons are ready for use
- 4.6.10 Place the stationary beacons high on the walls vertically in a way that will provide optimal ultrasonic coverage. Write down the beacon's height for future change in the settings. The help video on installation can be found here - <https://youtu.be/WYOHkLzmijs>



- 4.6.11 Connect the modem/router via USB to a Windows PC with the Dashboard installed
- 4.6.12 Run the Dashboard. In the left corner of the Dashboard, the modem should be shown as connected
- 4.6.13 Wake up all beacons by clicking on the buttons in the Dashboard on the panel
- 4.6.14 It may take up to 7-10 seconds for the beacons to wake up

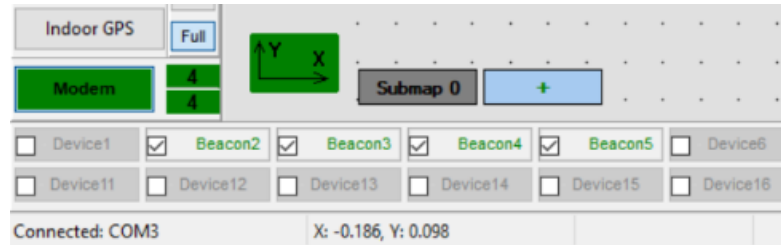

- 4.6.15 Notice, that if the modem is not active and is not powered, the beacons will go into sleep mode automatically after 1 minute
- 4.6.16 The system may run the frequency search, if it is the very first time you are waking up the beacons. If this step does not work, disconnect the modem and connect that beacon again via USB. Press the DEFAULT button in the Dashboard and the Read All button to make sure that the radio settings are the default ones
- 4.6.17 Check that the radio settings on the modem and the radio settings on the beacon are the same
- 4.6.18 Now you can check RSSI, voltage, ultrasonic filter settings, etc. on the panel on the right corner of the Dashboard

Supply voltage, V	3.95
Desired speed, % (0..100)	30
Height, m (-320.000..320.000)	0.000
Time from reset, h:m:s	00:01:26 R
Measured temperature, °C	23
RSSI, dBm	-28
Radio frequency band	915 MHz
Carrier frequency, MHz	919.000
Device address (0..254)	30
Radio channel	0
Ultrasonic frequency, Hz (100..65000)	25000
Filter selection	31 kHz

- 4.6.19 Enter the height of stationary beacons. Choose beacon in the list and enter height value

Read all		Write all	
CPU ID	Copy to clipboard	013326	
Firmware version	V6.192 Super-Beacon		
Power save functions	enabled		
Hedgehog mode	enabled		
Inverse system	disabled		
Distances only mode	disabled		
Supply voltage, V	3.95		
Desired speed, % (0..100)	30		
Height, m (-320.000..320.000)	0.000		
Time from reset, h:m:s	00:01:26 R		
Measured temperature, °C	23		
RSSI, dBm	-28		
Radio frequency band	915 MHz		
Carrier frequency, MHz	919.000		
Device address (0..254)	30		
Radio channel	0		
Ultrasonic frequency, Hz (100..65000)	25000		
Filter selection	31 kHz		



- 4.6.20 Enter the height for mobile beacon if you use 2D mode

4.6.21 In the current version one modem supports 250 beacons (mobile + stationary combined). If you do not see some of your connected beacons on the map, you may need to scroll to find their addresses

4.6.22 Double click on the device to put it into sleep mode or wake it up



Only 4 stationary beacons may be in 1 submap. If you wake up more beacons, create new submap for them. Or it won't be displayed on the map and in the table of distances

4.6.23 Build the map:

Industrial-RX beacons are not possible to build the map automatically, so you have to build it manually

Step 1. Open the Dashboard. You will see the table of distances

Step 2. Use right mouse click on cell you want to enter the distance. Additional menu will open. There you can control the table of distances. Choose **Enter distance for pair** to enter the value

HIDE	5	22	66	77
5		7.144	12.300	10.101
22	7.144		10.1	
66	12.389	10.122		
77	10.101	12.151	6.8	

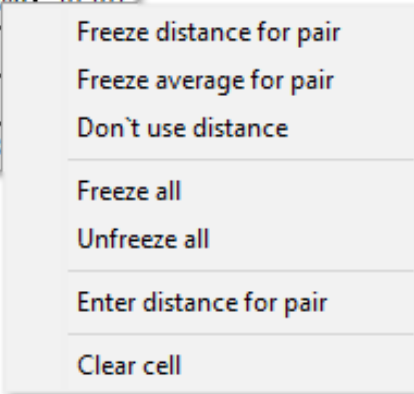

Step 3. Now, enter measured (measure it with laser distance meter or so) value. That values would not change until you unfreeze or clear it. Even if beacons had been moved, distance would stay. Be careful with frozen cells because a small mistake can cause a huge impact on your tracking

Step 4. Repeat for all cells

HIDE	6	22	66	77
6		8.000	4.200	11.400
22	8.000		13.100	6.500
66	4.200	13.100		10.800
77	11.400	6.500	10.800	

4.6.24 Freeze the map by clicking the button. Stationary beacons will stop measuring relative distances and will be ready to measure distance

from the mobile beacon(s)

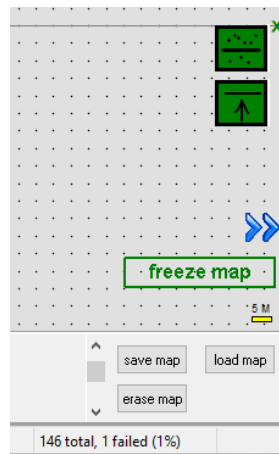

- 4.6.25 Turn on and wake up the mobile beacon following the same steps as with the stationary beacon: <https://youtu.be/A4aRsjH2-E>
- 4.6.26 If you see on the devices' panel in the Dashboard that the beacon is colored orange, it means there are some differences in some of the settings between beacons. For example, some sensors may be off or some ultrasonic or radio settings may be different. You can change the settings for sensors manually by clicking on the panel on the upper right corner of the Dashboard to change the cells from gray to green to turn on sensor. It is recommended that the default settings on all beacons and the modem be used if this is your first time using the system
- 4.6.27 After you freeze the map of stationary beacons, wake up the mobile beacon. After it wakes up, it will be traceable within 5-7 seconds
- 4.6.28 The system is now fully operational

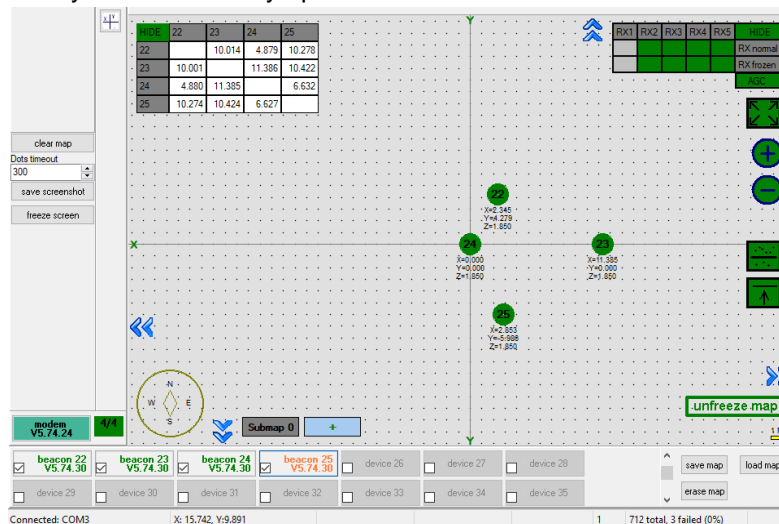

5. Setting up the system (IA)

5.1 Starter Set Super-MP-3D

The steps below describe the very first time you set up of the system. Super-Beacons with different ultrasonic frequencies and modem required.

This is Inverse Architecture. Super-Beacons should have different frequencies. Use IA Software ONLY.



You can't just switch Super-Beacon to another frequency, it is HW depended

Ultrasonic can't be changed to default. You must check the frequency on the white sticker



5.1.1 Unpack the system. Take a look at the similar unpacking video of HW v4.9. They are different, but have some similar basics: https://youtu.be/sOce7B2_6Sk

5.1.2 Charge all the beacons using USB cable. Full charging takes about 2-4 hours

5.1.3 Turn the beacons on: Place DIP switches as shown on the picture below

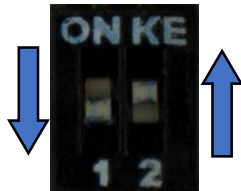

5.1.4 Download [SW Pack](#)

5.1.5 Update all the beacons

- You need Inverse Architecture SW (go to [marvelmind_SW_xxx_xx_xx\Software_ia](#))

- Run the Dashboard and update the SW for all beacons and modem using **Dashboard => Firmware => Choose the file => Program**

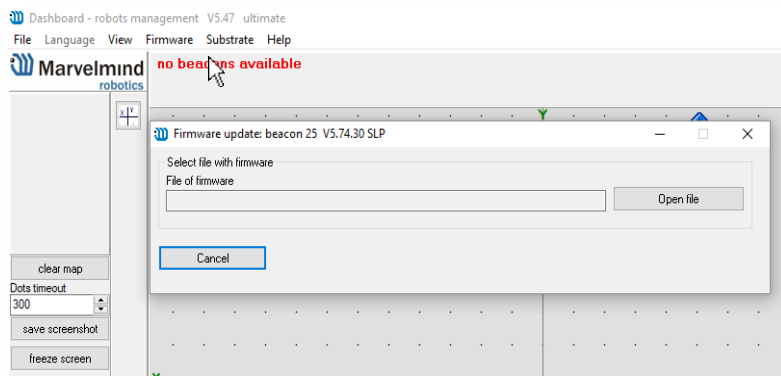

- If you see the message “Not found modem connection to computer through USB” in the Dashboard or your PC does not recognize beacons/modem, it usually means that the STM32 driver is not installed. To install the driver, download it with link at top window in the Dashboard and run the installation file, then click on the link under and install the driver

Ensure that:

- (g) You are programming the modem’s SW to the modem and the beacon’s SW to the beacon
- (h) You are using SW for 4.9, if you have HW v4.9; and you have the SW from the same SW pack, i.e., the Dashboard SW, modem SW, and beacon SW must be from the same SW pack. Don’t mix SW releases



If SW flashed SUCCESSFULLY, MOVE DIRECTLY TO 5.1.6. If you have some problems with HEX programming, use DFU programming:

DFU programming or SW uploading is used when HEX SW uploading in the Dashboard cannot be used. For example, when you are updating from a very old SW version or when the SW includes major changes to the system and the only possible way to update the SW is via DFU programming

- After the DFU SW upgrade, futures SW upgrades can be done in a regular manner via the Dashboard
- To start programming, move the beacon’s DIP switch to the DFU programming mode, as described in the paragraph on [DIP switch modes](#)
- Download the latest [SW package](#), unzip it, and select the proper version of the SW for your HW and for your frequency variant. Remember that for DFU programming, you should use DFU SW (DfuSe), not Dashboard’s .hex file
- Download DfuSe
- Here you will find different versions of DfuSe. v3.0.4 or v3.0.5, whichever works the best for your Windows: [DfuSe v3.0.4](#) or [DfuSe v.3.0.5](#)

DFU Programming:



- Put DIP switch into **Power = ON, DFU = ON**
- Connect the beacon via USB to your PC.
- Run DfuSe.
- Press the **RESET** button on your beacon.
- In the upper left corner of the DfuSe program, you will see a device connected in the DFU mode.
- Choose the DFU driver (file) for the beacon.

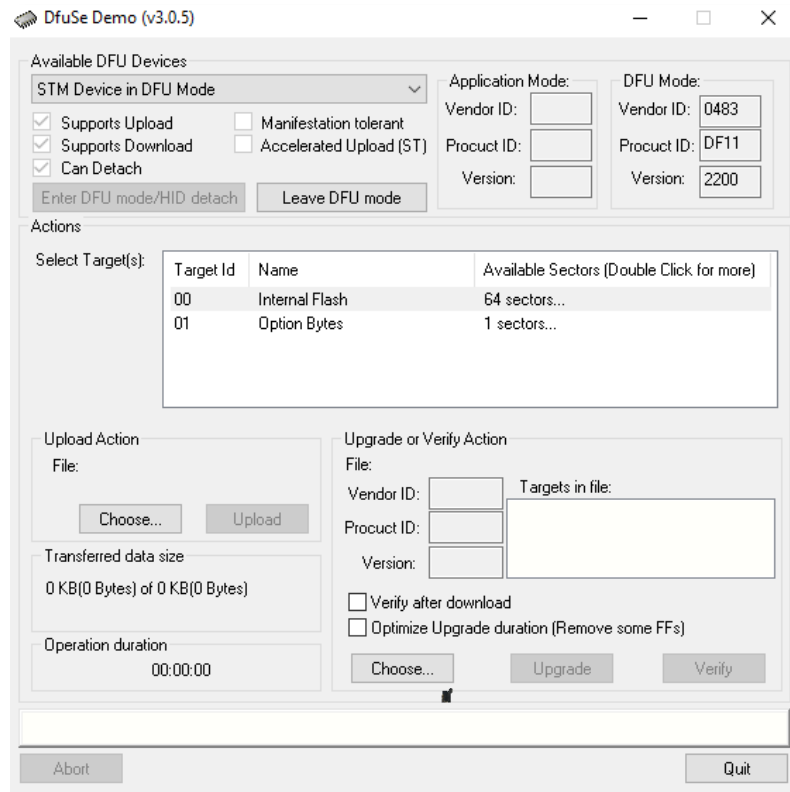

- Click the **UPGRADE** button
- After a couple of seconds, the DFU will be uploaded to the beacon. Make sure it takes 1–3 seconds and does not happen instantly. Otherwise, the SW has not been uploaded correctly. If the DFU appears to upload immediately, check the "Choose" button you used or change the version of DfuSe SW you selected
- Move the DIP switch into **Power = ON, DFU = OFF**
- Start the Dashboard and press the **RESET** button on the beacon
- Check SW on the beacon afterwards
- Everything should be OK with SW now. DFU programming is complete

Follow the same scenario for the modem:

- Here is the [link](#) for the modem DFU programming. The steps are similar to those for beacon DFU programming.



- After uploading DFU driver by DfuSe short circuit pins as shown on the picture (for v4.9) and press **Reset** button

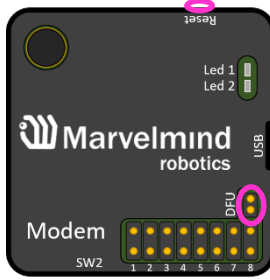

- Modem will go to DFU mode. Press **UPGRADE** button in the DfuSe program
- After a couple of seconds, the DFU will be uploaded to the modem. Make sure it takes 1-3 seconds and does not happen immediately. Otherwise, the SW has not uploaded correctly. If the DFU appears to upload immediately, check the "Choose" button you used or change the version of DfuSe SW to a different one.
- Disconnect the short circuit.
- Start the Dashboard and press **RESET** button

If you have uploaded the latest firmware for all of the boards, you can start to activate the system:

- 5.1.6 While the beacon or modem is connected to the Dashboard, click the **DEFAULT** button on the Dashboard to upload the default settings

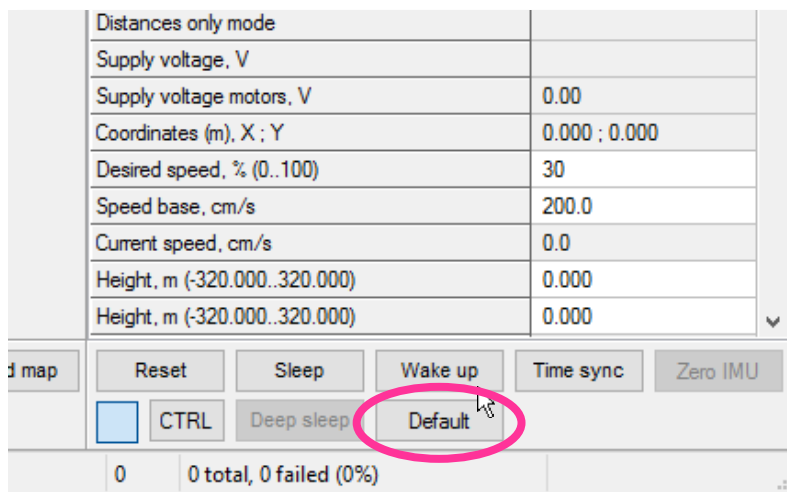

- 5.1.7 Write down the beacon's address for future use or change the address at your convenience as shown here

Hedgehog mode	enabled
Inverse system	enabled
Distances only mode	disabled
Supply voltage, V	3.70
Desired speed, % (0..100)	30
Time from reset, h:m:s	00:00:04 R
Measured temperature, °C	23
RSSI, dBm	-74
Radio frequency band	915 MHz
Carrier frequency, MHz	919.000
Device address (0..254)	154
Radio channel	0
Ultrasonic frequency, Hz (100..65000)	n/a
Filter selection	n/a
IMU	(+) expand
Parameters of radio	(+) expand
Ultrasound	(+) expand
Interfaces	(+) expand
Georeferencing	(+) expand
Misc. settings	(+) expand
Hedgehogs pairing	(+) expand
Real-time player	disabled
Real-time player backward (0..127)	3
Real-time player forward (0..127)	5

- 5.1.8 Press the RESET button on your beacons and modem after programming.
- 5.1.9 After programming devices with the latest software, the modem and beacons are ready for use.
- 5.1.10 Place the stationary beacons high on the walls vertically in a way that will provide optimal ultrasonic coverage. Write down the beacon's height for future change in the settings. The help video on installation can be found here - <https://youtu.be/WYOHkLzmijs>
- 5.1.11 Connect the modem/router via USB to a Windows PC with the Dashboard installed.
- 5.1.12 Run the Dashboard. In the left corner of the Dashboard, the modem should be shown as connected.
- 5.1.13 Wake up all beacons by clicking on the buttons in the Dashboard on the panel.
- 5.1.14 It may take up to 7-10 seconds for the beacons to wake up

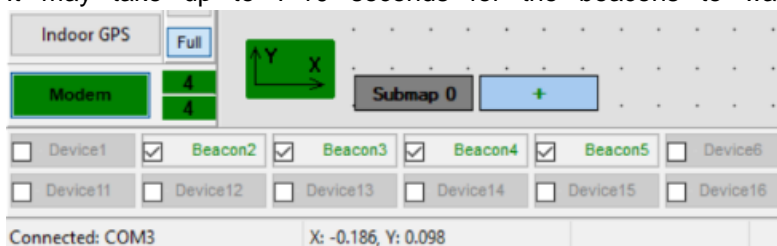

- 5.1.15 Notice, that if the modem is not active and is not powered, the beacons will go into sleep mode automatically after 1 minute
- 5.1.16 The system may run the frequency search, if it is the very first time you are waking up the beacons. If this step does not work, disconnect the modem and connect that beacon again via USB. Press the DEFAULT button in the Dashboard and the Read All button to make sure that the radio settings are the default ones
- 5.1.17 Check that the radio settings on the modem and the radio settings on the beacon are the same
- 5.1.18 Now you can check RSSI, voltage, ultrasonic filter settings, etc. on the panel on the right corner of the Dashboard

Supply voltage, V	3.95
Desired speed, % (0..100)	30
Height, m (-320.000..320.000)	0.000
Time from reset, h.m.s	00:01:26 R
Measured temperature, °C	23
RSSI, dBm	-28
Radio frequency band	915 MHz
Carrier frequency, MHz	919.000
Device address (0..254)	30
Radio channel	0
Ultrasonic frequency, Hz (100..65000)	25000
Filter selection	31 kHz



Only 4 stationary beacons may be in 1 submap. If you wake up more beacons, create new submap for them. Or it won't be displayed on the map and in the table of distances.

- 5.1.19 Enter the height of stationary beacons. Choose beacon in the list and enter height value

Read all		Write all	
CPU ID	Copy to clipboard	013326	
Firmware version	V6.192 Super-Beacon		
Power save functions	enabled		
Hedgehog mode	enabled		
Inverse system	disabled		
Distances only mode	disabled		
Supply voltage, V	3.95		
Desired speed, % (0..100)	30		
Height, m (-320.000..320.000)	0.000		
Time from reset, h.m.s	00:01:26 R		
Measured temperature, °C	23		
RSSI, dBm	-28		
Radio frequency band	915 MHz		
Carrier frequency, MHz	919.000		
Device address (0..254)	30		
Radio channel	0		
Ultrasonic frequency, Hz (100..65000)	25000		
Filter selection	31 kHz		



- 5.1.20 Enter the height for mobile beacon if you use 2D mode
- 5.1.21 In the current version one modem supports 250 beacons (mobile + stationary combined). If you do not see some of your connected beacons on the map, you may need to scroll to find their addresses
- 5.1.22 Double click on the device both to put it into sleep mode and to wake it up
- 5.1.23 The map will form and zoom in automatically

- 5.1.24 If the map does not form well, check the table of distances in the left corner of the Dashboard. The cells must be colored in white; it means the distances between stationary beacons are measured correctly

Dashboard - robots management V5.47 ultimate
File Language View Firmware Substrate Help

Marvelmind robotics

HIDE	22	23	24	25	26
22		10.394	11.365	9.992	
23	10.394		6.621	10.262	
24	11.365	6.621		4.873	
25	9.992	10.262	4.873		
26	10.088	7.094	1.937	3.659	

clear map
Dots timeout: 300
save screenshot
freeze screen

X=0.260
Y=4.514
Z=1.820

- 5.1.25 If you see in the table some empty cells or marked yellow/red, it is an indication that distances between Some beacons are measured inconsistently or not measured at all. Try to re-position them because usually there is an obstruction of some sort in the between the beacons. If you have any problems – check [Table of distances](#) chapter
- 5.1.26 Make a service zone, clicking on the map with **Shift+Left Mouse Button**. See [Submaps chapter](#) for more details
- 5.1.27 Freeze submap and by clicking the button. Stationary beacons will stop measuring relative distances and will be ready to measure distance from the mobile beacon(s).

freeze submap

save map load map
erase map

146 total, 1 failed (1%)



- 5.1.28 Turn on and wake up the mobile beacon following the same steps as with the stationary beacon: <https://youtu.be/A4aRsjH2-E>
- 5.1.29 If you see on the devices' panel in the Dashboard that the beacon is colored orange, it means there are some differences in some of the settings between beacons. For example, some sensors may be off or some ultrasonic or radio settings may be different. You can change the settings for sensors manually by clicking on the panel on the upper right corner of the Dashboard to change the cells from gray to green to turn on sensor. It is recommended that the default settings on all beacons and the modem be used if this is your first time using the system.
- 5.1.30 After you freeze the map of stationary beacons, wake up the mobile beacon. After it wakes up, it will be traceable in 5-7 seconds.

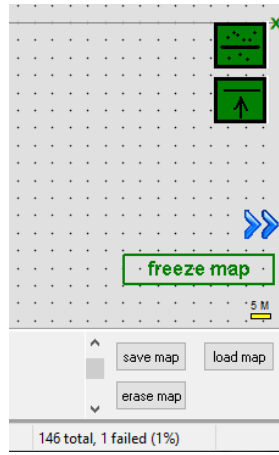

5.1.31 The system is now fully operational.

5.2 Starter Set IA-01-2D

The steps below describe the very first time you set up of the system. Mini-RX-beacon, HW v4.9 beacons and modem required.

This is Inverse Architecture. Beacons HW v4.9 should have different frequencies. Use IA Software ONLY.



You can't just switch HW v4.9 beacon to another frequency, it is HW depended

Ultrasonic can't be changed to default. You must check the frequency on the white sticker



5.2.1 Unpack the system. Take a look at the similar unpacking video of HW v4.9. They are different, but have some similar basics: https://youtu.be/sOce7B2_6Sk

5.2.2 Charge all the beacons using USB cable. Full charging takes about 1-2 hours

5.2.3 Turn the beacons on (To turn Mini-RXs on, carefully disassemble its housing and find DIP switches inside. It is necessary only for the first start. You can also turn it off with switches for long-term storage): Place DIP switches as shown on the picture below

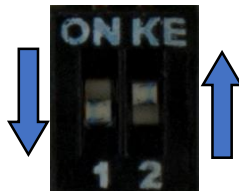

5.2.4 Download [SW Pack](#)

5.2.5 Update all the beacons

- You need Inverse Architecture SW (go to [marvelmind_SW_xxx_xx_xx\Software_ia](#))

- Run the Dashboard and update the SW for all beacons and modem using **Dashboard => Firmware => Choose the file => Program**

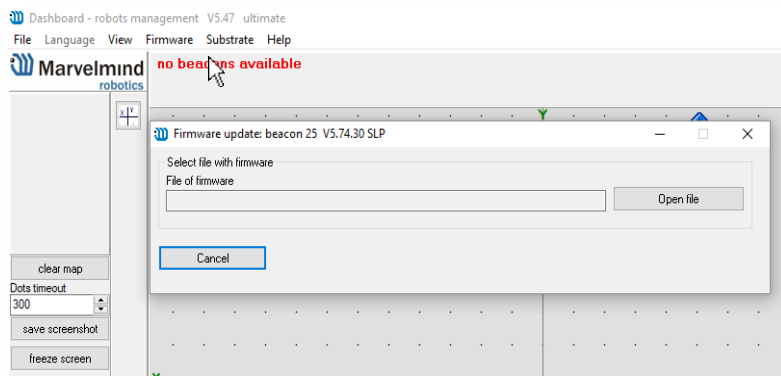

- If you see the message “Not found modem connection to computer through USB” in the Dashboard or your PC does not recognize beacons/modem, it usually means that the STM32 driver is not installed. To install the driver, download it with link at top window in the Dashboard and run the installation file, then click on the link under and install the driver

Ensure that:

- You are programming the modem’s SW to the modem and the beacon’s SW to the beacon
- You are using SW for 4.9, if you have HW v4.9; and you have the SW from the same SW pack, i.e., the Dashboard SW, modem SW, and beacon SW must be from the same SW pack. Don’t mix SW releases



If SW flashed SUCESFULLY, MOVE DIRECTLY TO 6.1.7. If you have some problems with HEX programming, use DFU programming:

DFU programming or SW uploading is used when HEX SW uploading in the Dashboard cannot be used. For example, when you are updating from a very old SW version or when the SW includes major changes to the system and the only possible way to update the SW is via DFU programming

- After the DFU SW upgrade, futures SW upgrades can be done in a regular manner via the Dashboard
- To start programming, move the beacon’s DIP switch to the DFU programming mode, as described in the paragraph on [DIP switch modes](#)
- Download the latest [SW package](#), unzip it, and select the proper version of the SW for your HW and for your frequency variant. Remember that for DFU programming, you should use DFU SW (DfuSe), not Dashboard’s .hex file
- Download DfuSe
- Here you will find different versions of DfuSe. v3.0.4 or v3.0.5, whichever works the best for your Windows: [DfuSe v3.0.4](#) or [DfuSe v.3.0.5](#)

DFU Programming:



- Put DIP switch into **Power = ON, DFU = ON** (DIP switch in Mini-RX and situated inside the body. To switch it, carefully disassemble the body).
- Connect the beacon via USB to your PC.
- Run DfuSe.
- Press the **RESET** button on your beacon.
- In the upper left corner of the DfuSe program, you will see a device connected in the DFU mode.
- Choose the DFU driver (file) for the beacon.

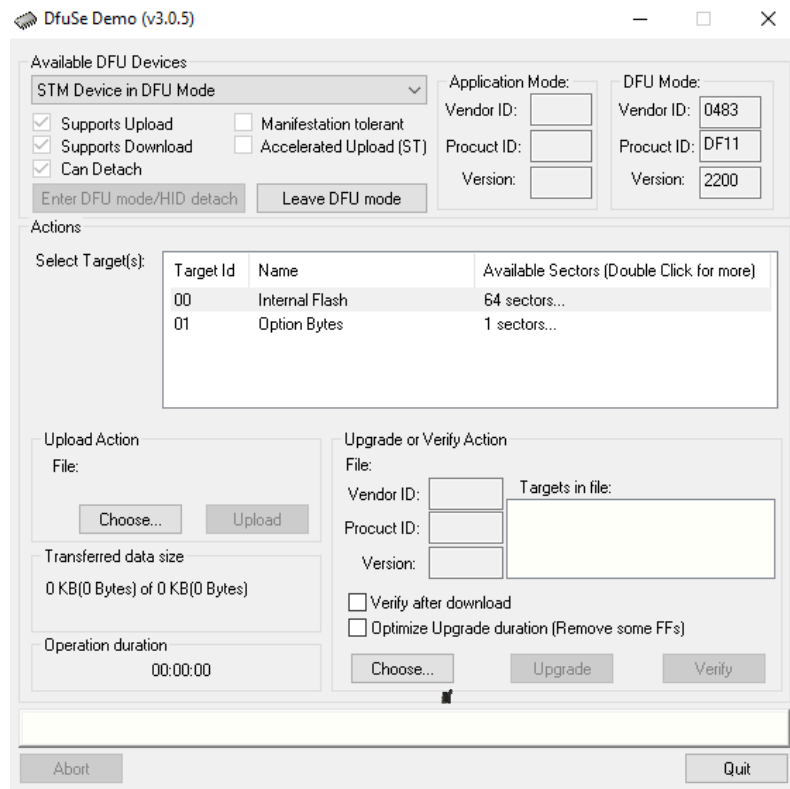

- Click the **UPGRADE** button
- After a couple of seconds, the DFU will be uploaded to the beacon. Make sure it takes 1–3 seconds and does not happen instantly. Otherwise, the SW has not been uploaded correctly. If the DFU appears to upload immediately, check the "Choose" button you used or change the version of DfuSe SW you selected
- Move the DIP switch into **Power = ON, DFU = OFF**
- Start the Dashboard and press the **RESET** button on the beacon
- Check SW on the beacon afterwards
- Everything should be OK with SW now. DFU programming is complete

Follow the same scenario for the modem:

- Here is the [link](#) for the modem DFU programming. The steps are similar to those for beacon DFU programming.



- After uploading DFU driver by DfuSe short circuit pins as shown on the picture (for v4.9) and press **Reset** button

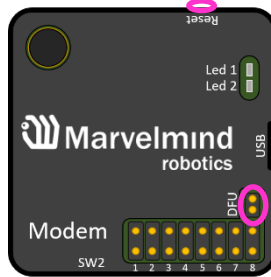

- Modem will go to DFU mode. Press **UPGRADE** button in the DfuSe program
- After a couple of seconds, the DFU will be uploaded to the modem. Make sure it takes 1-3 seconds and does not happen immediately. Otherwise, the SW has not uploaded correctly. If the DFU appears to upload immediately, check the "Choose" button you used or change the version of DfuSe SW to a different one.
- Disconnect the short circuit.
- Start the Dashboard and press **RESET** button

If you have uploaded the latest firmware for all the boards, you can start to activate the system:

- 5.2.6 While the beacon or modem is connected to the Dashboard, click the **DEFAULT** button on the Dashboard to upload the default settings

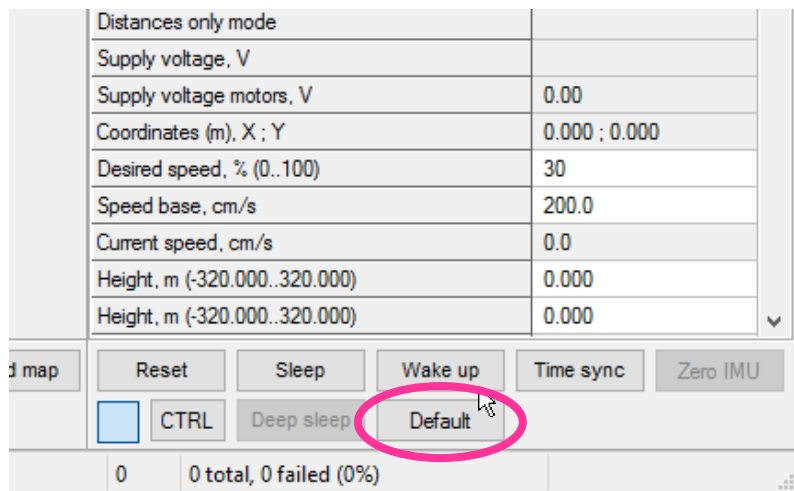

- 5.2.7 Write down the beacon's address for future use or change the address at your convenience as shown here

Hedgehog mode	enabled
Inverse system	enabled
Distances only mode	disabled
Supply voltage, V	3.70
Desired speed, % (0..100)	30
Time from reset, h:m:s	00:00:04 R
Measured temperature, °C	23
RSSI, dBm	-74
Radio frequency band	915 MHz
Carrier frequency, MHz	919.900
Device address (0..254)	154
Radio channel	0
Ultrasonic frequency, Hz (100..65000)	n/a
Filter selection	n/a
IMU	(+) expand
Parameters of radio	(+) expand
Ultrasound	(+) expand
Interfaces	(+) expand
Georeferencing	(+) expand
Misc. settings	(+) expand
Hedgehogs pairing	(+) expand
Real-time player	disabled
Real-time player backward (0..127)	3
Real-time player forward (0..127)	5

- 5.2.8 Press the RESET button on your beacons and modem after programming.
- 5.2.9 After programming devices with the latest software, the modem and beacons are ready for use.
- 5.2.10 Place the stationary beacons high on the walls vertically in a way that will provide optimal ultrasonic coverage. Write down the beacon's height for future change in the settings. The help video on installation can be found here - <https://youtu.be/WYOHkLzmijs>
- 5.2.11 Connect the modem/router via USB to a Windows PC with the Dashboard installed.
- 5.2.12 Run the Dashboard. In the left corner of the Dashboard, the modem should be shown as connected.
- 5.2.13 Wake up all beacons by clicking on the buttons in the Dashboard on the panel.
- 5.2.14 It may take up to 7-10 seconds for the beacons to wake up

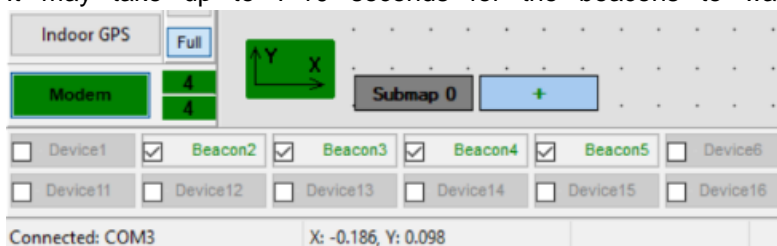

- 5.2.15 Notice, that if the modem is not active and is not powered, the beacons will go into sleep mode automatically after 1 minute
- 5.2.16 The system may run the frequency search, if it is the very first time you are waking up the beacons. If this step does not work, disconnect the modem and connect that beacon again via USB. Press the DEFAULT button in the Dashboard and the Read All button to make sure that the radio settings are the default ones
- 5.2.17 Check that the radio settings on the modem and the radio settings on the beacon are the same
- 5.2.18 Now you can check RSSI, voltage, ultrasonic filter settings, etc. on the panel on the right corner of the Dashboard

Supply voltage, V	3.95
Desired speed, % (0..100)	30
Height, m (-320.000..320.000)	0.000
Time from reset, h:m:s	00:01:26 R
Measured temperature, °C	23
RSSI, dBm	-28
Radio frequency band	915 MHz
Carrier frequency, MHz	919.000
Device address (0..254)	30
Radio channel	0
Ultrasonic frequency, Hz (100..65000)	25000
Filter selection	31 kHz

- 5.2.19 Enter the height of stationary beacons. Choose beacon in the list and enter height value

Read all		Write all
CPU ID	Copy to clipboard	013326
Firmware version		V6.192 Super-Beacon
Power save functions		enabled
Hedgehog mode		enabled
Inverse system		disabled
Distances only mode		disabled
Supply voltage, V		3.95
Desired speed, % (0..100)		30
Height, m (-320.000..320.000)		0.000
Time from reset, h:m:s		00:01:26 R
Measured temperature, °C		23
RSSI, dBm		-28
Radio frequency band		915 MHz
Carrier frequency, MHz		919.000
Device address (0..254)		30
Radio channel		0
Ultrasonic frequency, Hz (100..65000)		25000
Filter selection		31 kHz



- 5.2.20 Enter the height for mobile beacon if you use 2D mode

- 5.2.21 In current version one modem supports 250 beacons (mobile + stationary combined). If you do not see some of your connected beacons on the map, you may need to scroll to find their addresses.



Only 4 stationary beacons may be in 1 submap. If you wake up more beacons, create new submap for them. Or it won't be displayed on the map and in the table of distances.

- 5.2.22 Build the map:

Beacons with different frequencies are not able to build the map automatically, so you have to build it manually

Step 1. Open the Dashboard. You will see the table of distances.

Step 2. Use right mouse click on cell you want to enter the distance. Additional menu will open. There you can control the table of distances. Choose **Enter distance for pair** to enter the value.

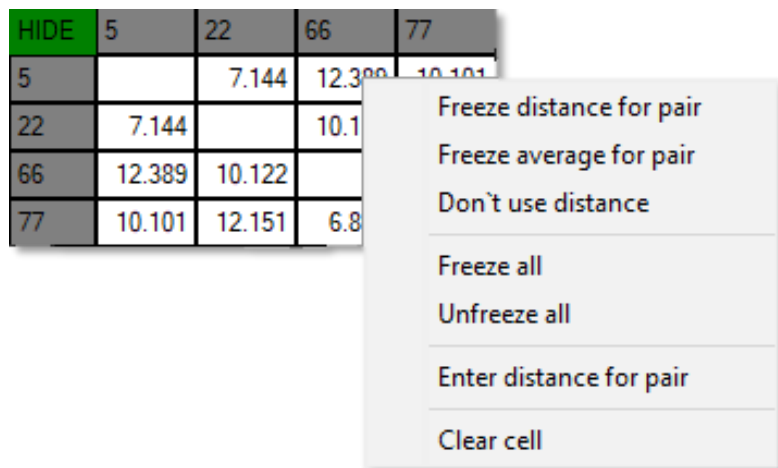

Step 3. Now, enter measured (measure it with laser distance meter or so) value. That values would not change until you unfreeze or clear it. Even if beacons had been moved, distance would stay. Be careful with frozen cells because a small mistake can cause a huge impact on your tracking.

Step 4. Repeat for all cells.

HIDE	6	22	66	77
6		8.000	4.200	11.400
22	8.000		13.100	6.500
66	4.200	13.100		10.800
77	11.400	6.500	10.800	

5.2.23 Freeze submap and by clicking the button. Stationary beacons will stop measuring relative distances and will be ready to measure distance from the mobile beacon(s).

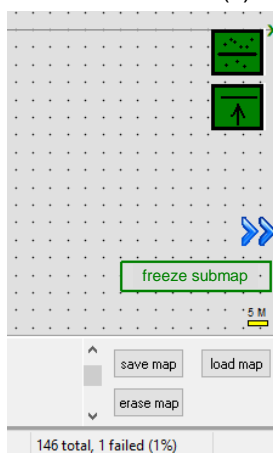

5.2.24 Turn on and wake up the mobile beacon following the same steps as with the stationary beacon: https://youtu.be/A4aRsjH2-_E

5.2.25 If you see on the devices' panel in the Dashboard that the beacon is colored orange, it means there are some differences in some of the settings between beacons. For example, some sensors may be off or

some ultrasonic or radio settings may be different. You can change the settings for sensors manually by clicking on the panel on the upper right corner of the Dashboard to change the cells from gray to green to turn on sensor. It is recommended that the default settings on all beacons and the modem be used if this is your first time using the system.

- 5.2.26 After you freeze the map of stationary beacons, wake up the mobile beacon. After it wakes up, it will be traceable in 5-7 seconds.

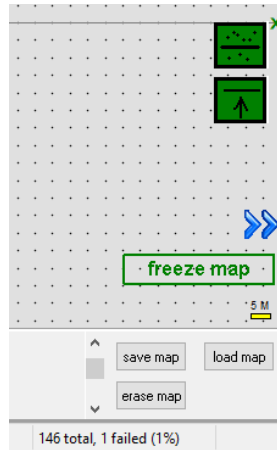

- 5.2.27 The system is now fully operational.

5.3 Starter Set IA-02-3D

The steps below describe the very first time you set up of the system. Mini-RX-beacon, HW v4.9 beacons and modem required.

This is Inverse Architecture. Beacons HW v4.9 should have different frequencies. Use IA Software ONLY.



You can't just switch HW v4.9 beacon to another frequency, it is HW depended

Ultrasonic can't be changed to default. You must check the frequency on the white sticker



5.3.1 Unpack the system. Take a look at the similar unpacking video of HW v4.9. They are different, but have some similar basics: https://youtu.be/sOce7B2_6Sk

5.3.2 Charge all the beacons using USB cable. Full charging takes about 1-2 hours

5.3.3 Turn the beacons on (To turn Mini-RXs on, carefully disassemble its housing and find DIP switches inside. It is necessary only for the first start. You can also turn it off with switches for long-term storage): Place

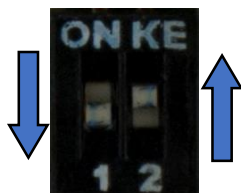

DIP switches as shown on the picture below

5.3.4 Download [SW Pack](#)

5.3.5 Update all the beacons

- You need Inverse Architecture SW (go to [marvelmind_SW_xxx_xx_xx\Software_ia](#))



- Run the Dashboard and update the SW for all beacons and modem using **Dashboard => Firmware => Choose the file => Program**

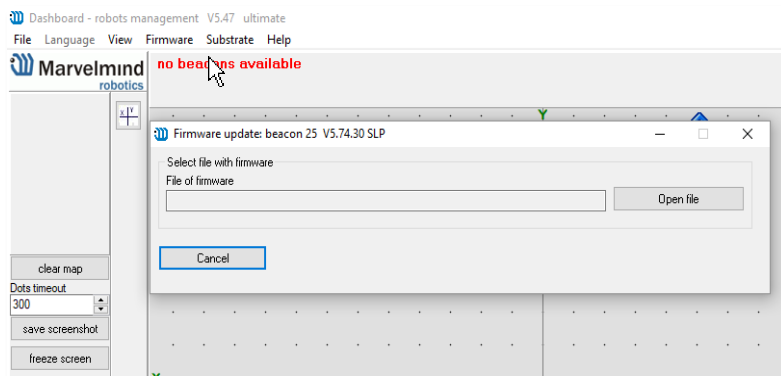

- If you see the message “Not found modem connection to computer through USB” in the Dashboard or your PC does not recognize beacons/modem, it usually means that the STM32 driver is not installed. To install the driver, download it with link at top window in the Dashboard and run the installation file, then click on the link under and install the driver

Ensure that:

- (k) You are programming the modem’s SW to the modem and the beacon’s SW to the beacon
- (l) You are using SW for 4.9, if you have HW v4.9; and you have the SW from the same SW pack, i.e., the Dashboard SW, modem SW, and beacon SW must be from the same SW pack. Don’t mix SW releases



If SW flashed SUCCESSFULLY, MOVE DIRECTLY TO 5.2.6. If you have some problems with HEX programming, use DFU programming:

DFU programming or SW uploading is used when HEX SW uploading in the Dashboard cannot be used. For example, when you are updating from a very old SW version or when the SW includes major changes to the system and the only possible way to update the SW is via DFU programming

- After the DFU SW upgrade, futures SW upgrades can be done in a regular manner via the Dashboard
- To start programming, move the beacon’s DIP switch to the DFU programming mode, as described in the paragraph on [DIP switch modes](#)
- Download the latest [SW package](#), unzip it, and select the proper version of the SW for your HW and for your frequency variant. Remember that for DFU programming, you should use DFU SW (DfuSe), not Dashboard’s .hex file
- Download DfuSe
- Here you will find different versions of DfuSe. v3.0.4 or v3.0.5, whichever works the best for your Windows: [DfuSe v3.0.4](#) or [DfuSe v.3.0.5](#)

DFU Programming:



- Put DIP switch into **Power = ON, DFU = ON** (DIP switch in Mini-RX and situated inside the body. To switch it, carefully disassemble the body).
- Connect the beacon via USB to your PC.
- Run DfuSe.
- Press the **RESET** button on your beacon.
- In the upper left corner of the DfuSe program, you will see a device connected in the DFU mode.
- Choose the DFU driver (file) for the beacon.

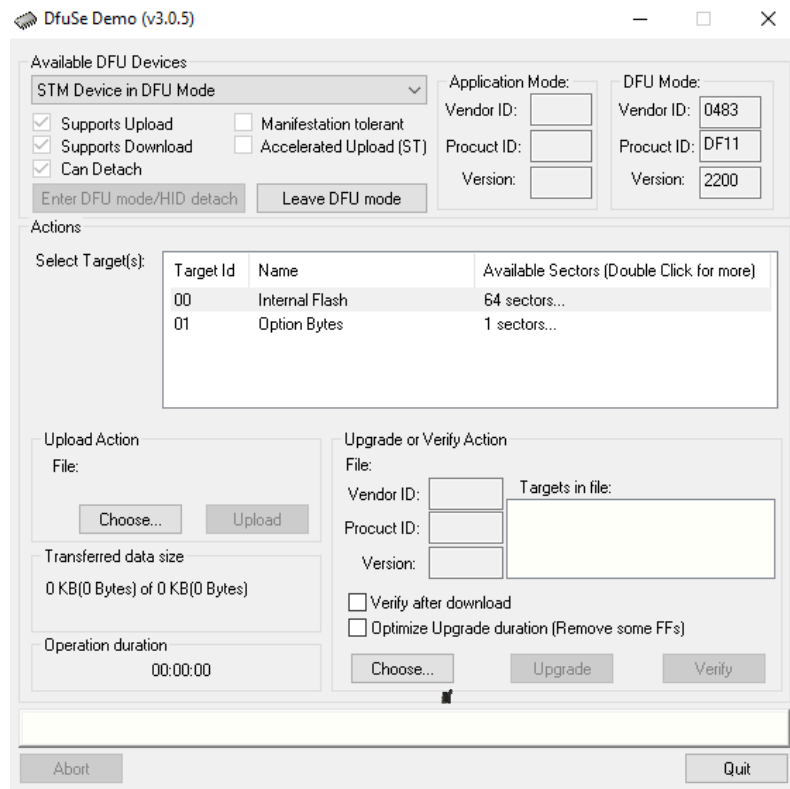

- Click the **UPGRADE** button
- After a couple of seconds, the DFU will be uploaded to the beacon. Make sure it takes 1–3 seconds and does not happen instantly. Otherwise, the SW has not been uploaded correctly. If the DFU appears to upload immediately, check the "Choose" button you used or change the version of DfuSe SW you selected
- Move the DIP switch into **Power = ON, DFU = OFF**
- Start the Dashboard and press the **RESET** button on the beacon
- Check SW on the beacon afterwards
- Everything should be OK with SW now. DFU programming is complete

Follow the same scenario for the modem:

- Here is the [link](#) for the modem DFU programming. The steps are similar to those for beacon DFU programming.



- After uploading DFU driver by DfuSe short circuit pins as shown on the picture (for v4.9) and press **Reset** button

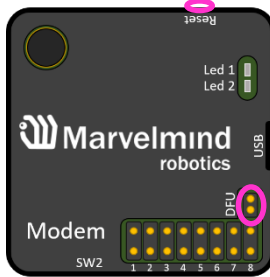

- Modem will go to DFU mode. Press **UPGRADE** button in the DfuSe program
- After a couple of seconds, the DFU will be uploaded to the modem. Make sure it takes 1-3 seconds and does not happen immediately. Otherwise, the SW has not uploaded correctly. If the DFU appears to upload immediately, check the "Choose" button you used or change the version of DfuSe SW to a different one.
- Disconnect the short circuit.
- Start the Dashboard and press **RESET** button

If you have uploaded the latest firmware for all of the boards, you can start to activate the system:

- 5.3.6 While the beacon or modem is connected to the Dashboard, click the **DEFAULT** button on the Dashboard to upload the default settings

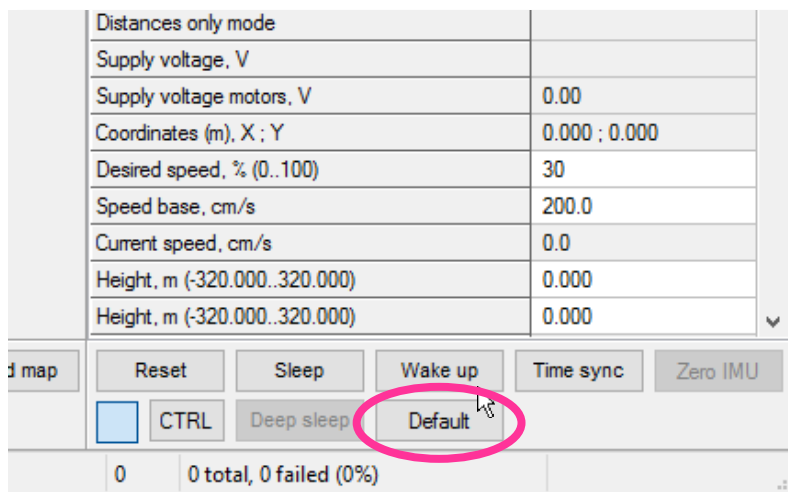

- 5.3.7 Write down the beacon's address for future use or change the address at your convenience as shown here

Hedgehog mode	enabled
Inverse system	enabled
Distances only mode	disabled
Supply voltage, V	3.70
Desired speed, % (0..100)	30
Time from reset, h:m:s	00:00:04 R
Measured temperature, °C	23
RSSI, dBm	-74
Radio frequency band	915 MHz
Carrier frequency, MHz	919.000
Device address (0..254)	154
Radio channel	0
Ultrasonic frequency, Hz (100..65000)	n/a
Filter selection	n/a
IMU	(+) expand
Parameters of radio	(+) expand
Ultrasound	(+) expand
Interfaces	(+) expand
Georeferencing	(+) expand
Misc. settings	(+) expand
Hedgehogs pairing	(+) expand
Real-time player	disabled
Real-time player backward (0..127)	3
Real-time player forward (0..127)	5

- 5.3.8 Press the RESET button on your beacons and modem after programming.
- 5.3.9 After programming devices with the latest software, the modem and beacons are ready for use.
- 5.3.10 Place the stationary beacons high on the walls vertically in a way that will provide optimal ultrasonic coverage. Write down the beacon's height for future change in the settings. The help video on installation can be found here - <https://youtu.be/WYOHkLzmijs>
- 5.3.11 Connect the modem/router via USB to a Windows PC with the Dashboard installed.
- 5.3.12 Run the Dashboard. In the left corner of the Dashboard, the modem should be shown as connected.
- 5.3.13 Wake up all beacons by clicking on the buttons in the Dashboard on the panel.
- 5.3.14 It may take up to 7-10 seconds for the beacons to wake up

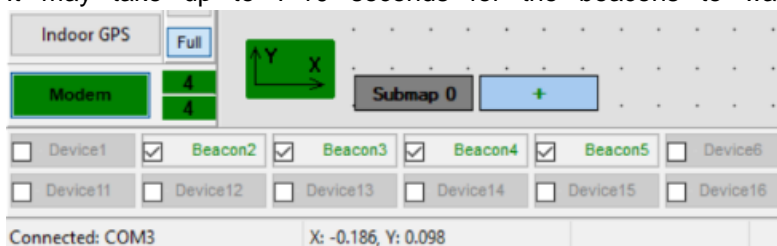

- 5.3.15 Notice, that if the modem is not active and is not powered, the beacons will go into sleep mode automatically after 1 minute
- 5.3.16 The system may run the frequency search, if it is the very first time you are waking up the beacons. If this step does not work, disconnect the modem and connect that beacon again via USB. Press the DEFAULT button in the Dashboard and the Read All button to make sure that the radio settings are the default ones
- 5.3.17 Check that the radio settings on the modem and the radio settings on the beacon are the same
- 5.3.18 Now you can check RSSI, voltage, ultrasonic filter settings, etc. on the panel on the right corner of the Dashboard

Supply voltage, V	3.95
Desired speed, % (0..100)	30
Height, m (-320.000..320.000)	0.000
Time from reset, h:m:s	00:01:26 R
Measured temperature, °C	23
RSSI, dBm	-28
Radio frequency band	915 MHz
Carrier frequency, MHz	919.000
Device address (0..254)	30
Radio channel	0
Ultrasonic frequency, Hz (100..65000)	25000
Filter selection	31 kHz

- 5.3.19 Enter the height of stationary beacons. Choose beacon in the list and enter height value

Read all		Write all
CPU ID	Copy to clipboard	013326
Firmware version		V6.192 Super-Beacon
Power save functions		enabled
Hedgehog mode		enabled
Inverse system		disabled
Distances only mode		disabled
Supply voltage, V		3.95
Desired speed, % (0..100)		30
Height, m (-320.000..320.000)		0.000
Time from reset, h:m:s		00:01:26 R
Measured temperature, °C		23
RSSI, dBm		-28
Radio frequency band		915 MHz
Carrier frequency, MHz		919.000
Device address (0..254)		30
Radio channel		0
Ultrasonic frequency, Hz (100..65000)		25000
Filter selection		31 kHz



- 5.3.20 Enter the height for mobile beacon if you use 2D mode

- 5.3.21 In current version one modem supports 250 beacons (mobile + stationary combined). If you do not see some of your connected beacons on the map, you may need to scroll to find their addresses.



Only 4 stationary beacons may be in 1 submap. If you wake up more beacons, create new submap for them. Or it won't be displayed on the map and in the table of distances.

- 5.3.22 Build the map:

Beacons with different frequencies are not able to build the map automatically, so you have to build it manually

Step 5. Open the Dashboard. You will see the table of distances.

Step 6. Use right mouse click on cell you want to enter the distance. Additional menu will open. There you can control the table of distances. Choose **Enter distance for pair** to enter the value.

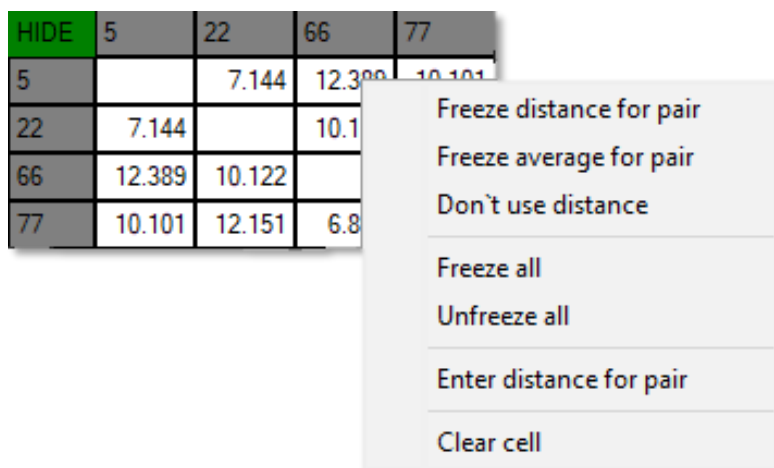

Step 7. Now, enter measured (measure it with laser distance meter or so) value. That values would not change until you unfreeze or clear it. Even if beacons had been moved, distance would stay. Be careful with frozen cells because a small mistake can cause a huge impact on your tracking.

Step 8. Repeat for all cells.

HIDE	6	22	66	77
6		8.000	4.200	11.400
22	8.000		13.100	6.500
66	4.200	13.100		10.800
77	11.400	6.500	10.800	

5.3.23 Freeze submap and by clicking the button. Stationary beacons will stop measuring relative distances and will be ready to measure distance from the mobile beacon(s).

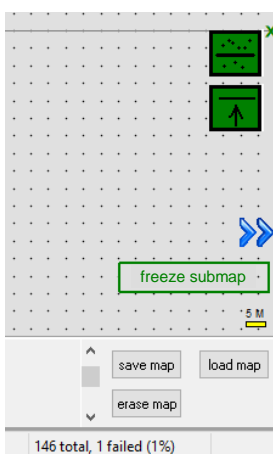

5.3.24 Turn on and wake up the mobile beacon following the same steps as with the stationary beacon: <https://youtu.be/A4aRsjH2-E>

5.3.25 If you see on the devices' panel in the Dashboard that the beacon is colored orange, it means there are some differences in some of the settings between beacons. For example, some sensors may be off or

some ultrasonic or radio settings may be different. You can change the settings for sensors manually by clicking on the panel on the upper right corner of the Dashboard to change the cells from gray to green to turn on sensor. It is recommended that the default settings on all beacons and the modem be used if this is your first time using the system.

- 5.3.26 After you freeze the map of stationary beacons, wake up the mobile beacon. After it wakes up, it will be traceable in 5-7 seconds.

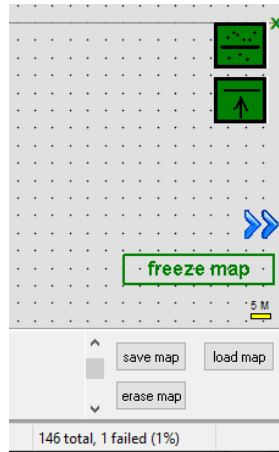

- 5.3.27 The system is now fully operational.

6. Dashboard menu and parameters

6.1 Dashboard general view

- This picture shows the Dashboard's general interface and items' positions

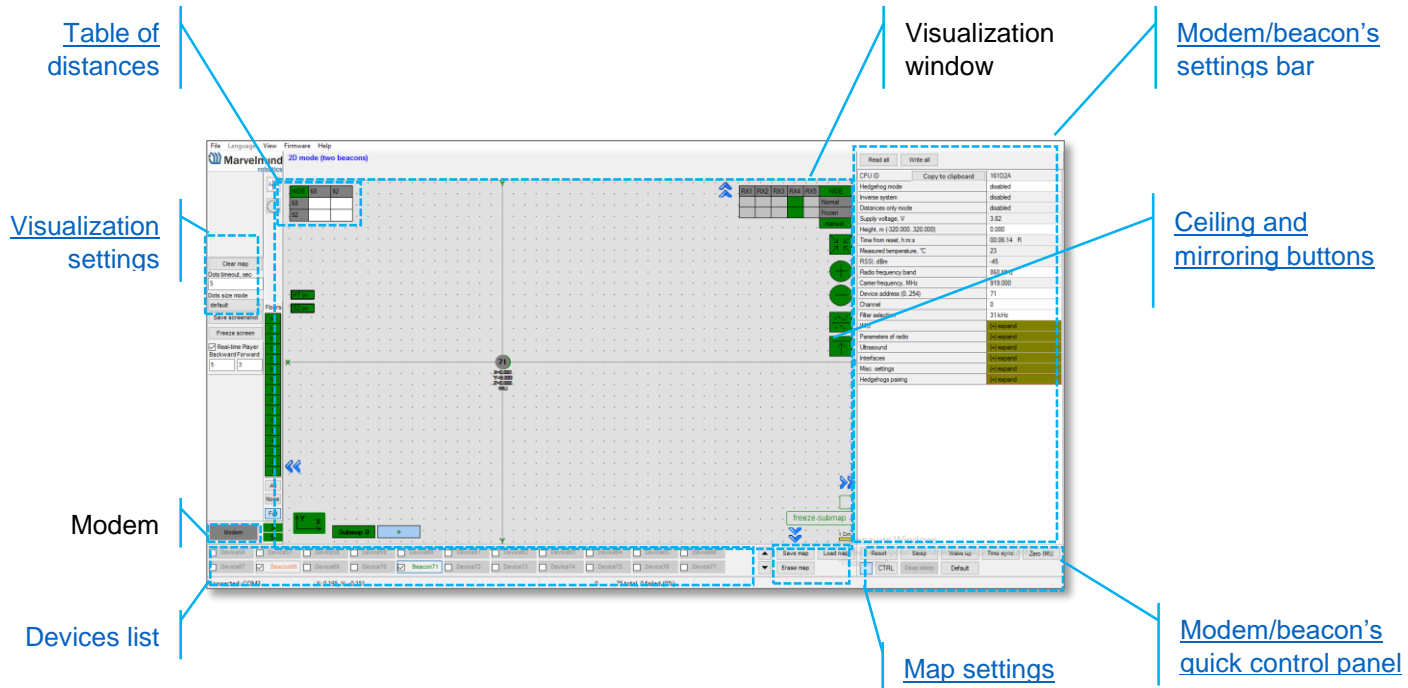

6.2 Table of distances

Table of distances shows the measured distance between all beacons. The map and its graphical visualization depend on distances, which is a very important part of the system.

There are two ways of measuring:

- 1) Measuring by ultrasound (automatic)
- 2) Measuring by user (manual)

***Measuring by ultrasound is impossible for Mini-RX and Industrial-RX beacons**

***In noisy cases and cases with long distances it is better to use manual input**

1) Measuring by ultrasound:

- In most cases, the system builds the table of distances automatically. If everything is good, there would be figures in cells, they would be changing a little; the color of each cell would be white

HIDE	5	22	66	77
5		7.144	12.389	10.101
22	7.144		10.122	12.151
66	12.389	10.122		6.879
77	10.101	12.151	6.879	

- If color differs, check the colors' definitions (next page) and solve the problem
- Freeze the map only if cells are white

2) Measuring by user (**necessary for Mini-RX beacons and noisy cases**):

- Use manual input if table of distances didn't build. It may happen if environment is very noisy, or distances are very huge
- In that case, cells' color would be green
- Be careful with figures because a small mistake in the values will cause mistakes in location

How to freeze/enter distance manually:

Step 1. Open the Dashboard. You will see the table of distances

Step 2. Use right mouse click on cell you want to freeze/enter. Additional menu will open. There you can control the table of distances. Choose **Freeze distance for pair** to freeze it

HIDE	5	22	66	77
5		7.144	12.389	10.101
22	7.144		10.122	12.151
66	12.389	10.122		6.879
77	10.101	12.151	6.879	

- Freeze distance for pair
- Freeze average for pair
- Don't use distance
- Freeze all
- Unfreeze all
- Enter distance for pair
- Clear cell

Step 3. Now, cells are frozen. That values would not change until you unfreeze it. Even if beacons had been moved, distance would stay. Be careful with frozen cells because a small mistake can cause a huge impact on your tracking

HIDE	6	22	66	77
6		8.000	27.378	5.054
22	8.000		28.688	18.739
66	33.772	29.794		18.741
77	17.315	7.585	3.522	

Step 4. Repeat for all cells

HIDE	6	22	66	77
6		8.000	4.200	11.400
22	8.000		13.100	6.500
66	4.200	13.100		10.800
77	11.400	6.500	10.800	



- White means that everything is good, you can freeze the map



- Yellow means that something seems to be wrong, check distances and sensors before freezing



- Red means some critical misses, **DO NOT freeze the map**. Manually measure and enter distances



- Green means frozen distance, you can freeze the map, but be careful with values

6.3 Devices list

Devices list contains information about all the beacons in the system. It also allows to search, add and delete it.

<input type="checkbox"/> Device56	<input type="checkbox"/> Device57	<input type="checkbox"/> Device58	<input type="checkbox"/> Device59	<input type="checkbox"/> Device60	<input type="checkbox"/> Device61	<input type="checkbox"/> Device62	<input type="checkbox"/> Device63	<input type="checkbox"/> Device64	<input type="checkbox"/> Device65	<input type="checkbox"/> Device66	▲
<input type="checkbox"/> Device67	<input checked="" type="checkbox"/> Beacon68	<input type="checkbox"/> Device69	<input type="checkbox"/> Device70	<input checked="" type="checkbox"/> Beacon71	<input type="checkbox"/> Device72	<input type="checkbox"/> Device73	<input type="checkbox"/> Device74	<input type="checkbox"/> Device75	<input type="checkbox"/> Device76	<input type="checkbox"/> Device77	▼
Connected: COM3		X: 0.195, Y: -0.151						0		75 total, 0 failed (0%)	

Devices in this section are divided into two types:

- 1) Stationary beacon (beacon)
 - 2) Mobile beacon (hedge)
 - Devices list allows user to manage devices
 - Use double click to put beacon into sleep mode
- 1) Stationary beacon (beacon)
 - Press right mouse button and additional menu will open
 - There you can:
 - Remove beacon from current submap
 - Remove beacon from the whole network
 - Manually setup coordinates (x, y, z)

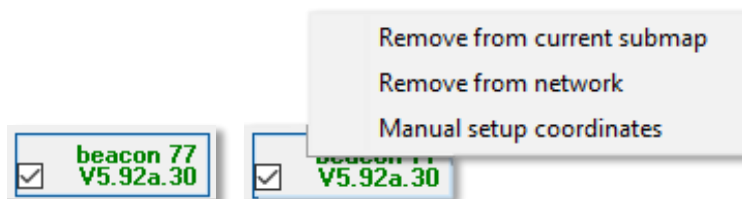

- 2) Mobile beacon (hedge)
 - Press right mouse button and additional menu will open
 - There you can:
 - Remove beacon from the network
 - Setup movement path
 - Upload zones (allowed and denied)
 - Manually setup coordinates (x, y, z)

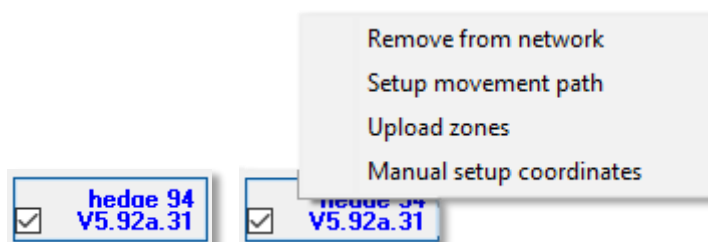

6.4 Visualization settings

Visualization settings window has some functions to control visualization process:



- Clear map – clear all movement path
- Dots timeout – time of path's existence (Video: [Help: Dots timeout](#))
- Dots size mode – size of dots
- Save screenshot – files save to **Dashboard's folder/screenshots**
- Freeze screen – The map freeze, no updates of the path

A screenshot of the visualization settings window. It contains the following elements from top to bottom: a 'Clear map' button; a 'Dots timeout, sec' label followed by a text input field containing the number '5' and a small up/down arrow control; a 'Dots size mode' label followed by a dropdown menu showing 'default' with a downward arrow; a 'Save screenshot' button; and a 'Freeze screen' button.

6.5 Map Settings

Map Settings offer some helpful tools:

- Save map – saves map as *.ini* file into **Dashboard folder/maps**
- Load map – loads map from *.ini* format file
- Erase map – erases map and clears it

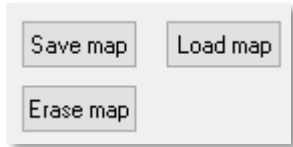

6.6 Modem/beacon's quick control panel

Control panel allows user to interact with devices. It can work with one device, or with all devices in the system.

List of functions:

Reset – Resets device

Sleep – Send device asleep (battery economy mode)

Wake up – Wakes up device (from sleeping mode)

Default – Drops all device's settings to factory default

Time sync – Sends time from your PC to hedgehog (for stream it out via UART)

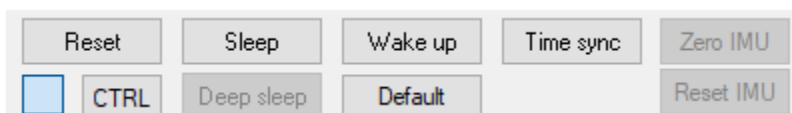

Additional Ctrl feature:

To apply action to all beacons in the system, use **Ctrl + left mouse click** on button. Applicable only for buttons that turn **bold** while Ctrl is pressed.

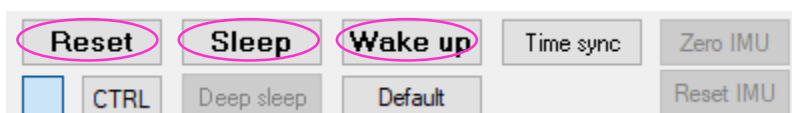

6.7 CEILING and MIRRORING buttons on the Dashboard

- The **MIRRORING** button allows the map to be display as a mirror reflection
- The **CEILING** button shows where the mobile beacon is located with respect to the stationary beacons
- When the arrow points up, it means that the mobile beacon is below the stationary beacons
- When the arrow points down, it means that the mobile beacon is **above the stationary beacons**

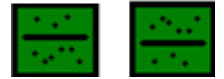



6.8 Detailed settings

This bar allows user to adjust devices very precisely. It contains a lot of parameters for advanced usage

Modem Settings

CPU ID	Copy to clipboard	143B43	Unique processor ID for each device (beacon or modem)
Location update rate		16 Hz	Location update rate settings: 1/20Hz – 16Hz+. Notice that real update rate may be limited by distances between beacons or radio profile
Update rate speedup		none	TBD
Maximum speed, m/s (0.1..60.0)		5.0	Internal filter. More – faster objects can be tracked. Less – better filtering against location jumps
Power save functions		disabled	Set of power saving features. May not work in all settings or all SW releases. Keep disabled, if unsure
Window of averaging (0..16)		4	Averaging between location update measurements. More value – less location jitter, but higher latency
Distance filter (0..16)		0	Filter of distances (as opposed to filter of locations). More – better filtering, but may be too conservative and “kill” good measurements
Advanced settings		(+) expand	Keep Enabled normally. Switch to cm for backward compatibility
High resolution mode (mm)		enabled	If map is frozen, new beacons will be accepted in the map, if enabled
Accept new/woken devices		enabled	TBD
Inverse system		enabled	
Distances only mode		disabled	
Supply voltage, V		5.13	
High voltage, V		n/a	
Time from reset, h:m:s		00:01:09 R	
Temperature of air, °C (-20..60)		23	
RSSI, dBm		-69	
Radio frequency band		915 MHz	
Carrier frequency, MHz		919.000	
Device address (0..99)		1	
Channel		0	
Parameters of radio		(+) expand	
Interfaces		(+) expand	
Georeferencing		(+) expand	
Stationary beacons visible		enabled	
Service zones visible		enabled	
Service zones active		enabled	

CPU ID	Copy to clipboard	143B43
Location update rate		16 Hz
Update rate speedup		none
Maximum speed, m/s (0.1..60.0)		5.0
Power save functions		disabled
Window of averaging (0..16)		4
Distance filter (0..16)		0
Advanced settings		(+) expand
High resolution mode (mm)		enabled
Accept new/woken devices		enabled
Inverse system		enabled
Distances only mode		disabled
Supply voltage, V		5.13
High voltage, V		n/a
Time from reset, h:m:s		00:01:09 R
Temperature of air, °C (-20..60)		23
RSSI, dBm		-69
Radio frequency band		915 MHz
Carrier frequency, MHz		919.000
Device address (0..99)		1
Channel		0
Parameters of radio		(+) expand
Interfaces		(+) expand
Georeferencing		(+) expand
Stationary beacons visible		enabled
Service zones visible		enabled
Service zones active		enabled

TBD

Power supply voltage of the device 5V+-0.2V is OK

N/A

Time from the latest reset

Measured temperature of the processor's crystal

Strength of the radio signal from modem to beacons and vice versa. Maintain in the range of -25dBm to -80..-90dBm. Higher value - may overload. Lower – lost packets

Chosen working band

Exact working frequency

Logical address of the device. Keep 2..255 for beacons. Address

Pre-selected channel – one of the radio channels for communication between modem and beacons

If enabled, beacons will be seen as green dots on the map. If disabled, they won't be seen at all

Enable or disable visibility of Service Areas (Zones)

Make Service Zones active or not active

Advanced settings

Advanced settings	(-) collapse
Movement filtering	disabled
Use pairs of beacons	disabled
Analyze signal quality	enabled
Minimum signal quality (0..100)	10
Track with low signal	blue

TBD

Enabling will allow direction along with location:

TBD

TBD

TBD

Parameters of radio

Parameters of radio	(-) collapse
Base frequency, MHz	919.000
Radio profile	38 Kbps
Device address (0..99)	77
Channel	1
Modulation	GFSK
Power of TX	9 dBm
Channel spacing, KHz (25.391..405.457)	49.190
Intermediate frequency (ID), KHz (0..787)	152
Offset frequency, KHz (-203.13..201.54)	76.16
Deviation frequency, KHz (1.587..380.859)	20.628
Channel bandwidth, KHz (58.036..812.500)	101.553
CCA mode	always
DC blocking filter	enabled
Manchester	disabled
Whitening	enabled
FEC	enabled

Real carrier frequency

Selected radio profile with a set of profile settings. Choose between 38kbps (better range and interference immunity, but slower); 153kbps – balanced; and 500kbps – the fastest, but the lowest radio range and least immune to interference

Logical address of the device. Distinguish of beacon from another

One of a predefined radio frequency channels

Modulation – a part of the radio profile. Only for advanced users

Only for advanced users

Only for advanced users

Only for advanced users

Parameters of radio	(-) collapse
Base frequency, MHz	919.000
Radio profile	38 Kbps
Device address (0..99)	77
Channel	1
Modulation	GFSK
Power of TX	9 dBm
Channel spacing, KHz (25.391..405.457)	49.190
Intermediate frequency (ID), KHz (0..787)	152
Offset frequency, KHz (-203.13..201.54)	76.16
Deviation frequency, KHz (1.587..380.859)	20.628
Channel bandwidth, KHz (58.036..812.500)	101.553
CCA mode	always
DC blocking filter	enabled
Manchester	disabled
Whitening	enabled
FEC	enabled

Radio profile settings. No need to change manually. Only for advanced users

Radio profile settings. No need to change manually. Only for advanced users

Radio profile settings. No need to change manually. Only for advanced users

Radio profile settings. No need to change manually. Only for advanced users

Radio profile settings. No need to change manually. Only for advanced users

Radio profile settings. No need to change manually. Only for advanced users

Radio profile settings. No need to change manually. Only for advanced users

Radio profile settings. No need to change manually. Only for advanced users

Beacon's settings

CPU ID	Copy to clipboard	172E42
Hedgehog mode		
Inverse system		enabled
Distances only mode		disabled
Supply voltage, V		3.96
High voltage, V		n/a
Height, m (-320.000..320.000)		0.000
Time from reset, h:m:s		00:00:13 R
Measured temperature, °C		39
RSSI, dBm		-46
Radio frequency band		
Carrier frequency, MHz		919.000
Device address (0..99)		22
Channel		0
Minimum threshold (-10..-2000)		
IMU		(+) expand
Parameters of radio		(+) expand
Ultrasound		(+) expand
Interfaces		(+) expand
Misc. settings		(+) expand
Hedgehogs pairing		(+) expand

Unique CPU ID

Enable for mobile beacon and disable for stationary beacon

TBD

TBD

Measured voltage of internal battery

NA

Height – must be set for stationary beacons.
Must also be set for mobile beacons in 1D or 2D modes

Time from the latest reset

CPU ID	Copy to clipboard	172E42
Hedgehog mode		
Inverse system		enabled
Distances only mode		disabled
Supply voltage, V		3.96
High voltage, V		n/a
Height, m (-320.000..320.000)		0.000
Time from reset, h:m:s		00:00:13 R
Measured temperature, °C		39
RSSI, dBm		-46
Radio frequency band		
Carrier frequency, MHz		919.000
Device address (0..99)		22
Channel		0
Minimum threshold (-10..-2000)		
IMU		(+) expand
Parameters of radio		(+) expand
Ultrasound		(+) expand
Interfaces		(+) expand
Misc. settings		(+) expand
Hedgehogs pairing		(+) expand

Processor's crystal's temperature

Strength of the radio signal from this beacon to the modem, i.e. how the modem "hears" the beacon over radio. Keep below -25dBm and above -80..90dBm to avoid losses of packets. Lower end depends on radio profile and interference

Select radio frequency band according to your HW: 433MHz or 915MHz

Real carrier frequency

Selected device's address

Selected radio channel

TBD

IMU

IMU	(-) collapse
Ax zero	-10
Ay zero	8
Az zero	-122
Ax K	0.982
Ay K	0.973
Az K	0.982

Calibration settings of embedded IMU: X shift

Calibration settings of embedded IMU: Y shift

Calibration settings of embedded IMU: Z shift

Calibration settings of embedded IMU: X scale

Calibration settings of embedded IMU: Y scale

Calibration settings of embedded IMU: Z scale

Parameters of radio

Parameters of radio	(-) collapse
Base frequency, MHz	919.000
Radio profile	38 Kbps
Device address (0..99)	77
Channel	1
Modulation	GFSK
Power of TX	9 dBm
Channel spacing, KHz (25.391..405.457)	49.190
Intermediate frequency (ID), KHz (0..787)	152
Offset frequency, KHz (-203.13..201.54)	76.16
Deviation frequency, KHz (1.587..380.859)	20.628
Channel bandwidth, KHz (58.036..812.500)	101.553
CCA mode	always
DC blocking filter	enabled
Manchester	disabled
Whitening	enabled
FEC	enabled

Real carrier frequency

Radio profile that is linked with many radio settings below. Helps to set them at once by choosing the profile. See similar in modem for more info

Device address – shall be set for each beacon different under one modem

One of the pre-selected frequency channels

Radio profile settings. No need to change manually. Only for advanced users

Radio profile settings. No need to change manually. Only for advanced users

Radio profile settings. No need to change manually. Only for advanced users

Radio profile settings. No need to change manually. Only for advanced users

Parameters of radio	(-) collapse
Base frequency, MHz	919.000
Radio profile	38 Kbps
Device address (0..99)	77
Channel	1
Modulation	GFSK
Power of TX	9 dBm
Channel spacing, KHz (25.391..405.457)	49.190
Intermediate frequency (ID), KHz (0..787)	152
Offset frequency, KHz (-203.13..201.54)	76.16
Deviation frequency, KHz (1.587..380.859)	20.628
Channel bandwidth, KHz (58.036..812.500)	101.553
CCA mode	always
DC blocking filter	enabled
Manchester	disabled
Whitening	enabled
FEC	enabled

Radio profile settings. No need to change manually. Only for advanced users

Radio profile settings. No need to change manually. Only for advanced users

Radio profile settings. No need to change manually. Only for advanced users

Radio profile settings. No need to change manually. Only for advanced users

Radio profile settings. No need to change manually. Only for advanced users

Radio profile settings. No need to change manually. Only for advanced users

Radio profile settings. No need to change manually. Only for advanced users

Radio profile settings. No need to change manually. Only for advanced users

Ultrasound

Ultrasound	(-) collapse
Mode of work	TX+RX normal
High voltage TX settings	(+) expand
Analog power in sleep	disabled
Power after transmission	not turn off
Transmitter mode	PWM
Frequency, Hz (100..65000)	31000
Duty, % (1..99)	50
Number of periods (1..100)	5
Amplifier limitation (calibrated)	4000
Amplification	AGC
Time gain control	disabled
AGC desired level (-1800..0)	-500
AGC hysteresis (10..2000)	130
AGC step, dB (1..20)	3
Mode of threshold	automatic
Minimum threshold (-10..-2000)	-50
Threshold to noise, dB (3..100)	6
Signal detection	by ADC
Periods for detector (3..50)	5
Min. speed of raise, LSB/cm (0.5..127.0)	5.0
Min. over raise for new front (0..200)	10
Coef. of estimated front quality (0..200)	8
Maximum line gradient down, % (0..200)	0
Maximum triple deviation, % (0..250)	150
Maximum points to skip (0..5)	2

TX-RX – regular mode. Use it. The rest - internal

TBD

Power saving features. If not sure, keep default

Power saving features. If not sure, keep default

TBD

Frequency of ultrasonic pulses – set according to your HW

50% - default. 1% ... 99% lower strength of ultrasonic. Keep default

Number of ultrasonic pulses the TX beacon emits. More – stronger, but longer echo. For small distances – 1-10 periods. 20-30 – for 10-20 meters. For 20+ m – 50 periods

Internal settings

Automatic or manual gain control. Manual can be useful in special conditions: too high external audio noise, for example

Ultrasound	(-) collapse
Mode of work	TX+RX normal
High voltage TX settings	(+) expand
Analog power in sleep	disabled
Power after transmission	not turn off
Transmitter mode	PWM
Frequency, Hz (100..65000)	31000
Duty, % (1..99)	50
Number of periods (1..100)	5
Amplifier limitation (calibrated)	4000
Amplification	AGC
Time gain control	disabled
AGC desired level (-1800..0)	-500
AGC hysteresis (10..2000)	130
AGC step, dB (1..20)	3
Mode of threshold	automatic
Minimum threshold (-10..-2000)	-50
Threshold to noise, dB (3..100)	6
Signal detection	by ADC
Periods for detector (3..50)	5
Min. speed of raise, LSB/cm (0.5..127.0)	5.0
Min. over raise for new front (0..200)	10
Coef. of estimated front quality (0..200)	8
Maximum line gradient down, % (0..200)	0
Maximum triple deviation, % (0..250)	150
Maximum points to skip (0..5)	2

TBD

AGC settings. For advanced users only

AGC settings. For advanced users only

AGC settings. For advanced users only

AGC settings. For advanced users only

Deep ultrasonic trigger settings. For special cases only

Deep ultrasonic trigger settings. For special cases only

Keep ADC

Deep ultrasonic trigger settings. For special cases only

Deep ultrasonic trigger settings. For special cases only

Ultrasound	(-) collapse
Mode of work	TX+RX normal
High voltage TX settings	(+) expand
Analog power in sleep	disabled
Power after transmission	not tum off
Transmitter mode	PWM
Frequency, Hz (100..65000)	31000
Duty, % (1..99)	50
Number of periods (1..100)	5
Amplifier limitation (calibrated)	4000
Amplification	AGC
Time gain control	disabled
AGC desired level (-1800..0)	-500
AGC hysteresis (10..2000)	130
AGC step, dB (1..20)	3
Mode of threshold	automatic
Minimum threshold (-10..-2000)	-50
Threshold to noise, dB (3..100)	6
Signal detection	by ADC
Periods for detector (3..50)	5
Min. speed of raise, LSB/cm (0.5..127.0)	5.0
Min. over raise for new front (0..200)	10
Coef. of estimated front quality (0..200)	8
Maximum line gradient down, % (0..200)	0
Maximum triple deviation, % (0..250)	150
Maximum points to skip (0..5)	2

Deep ultrasonic trigger settings. For special cases only

Deep ultrasonic trigger settings. For special cases only

Deep ultrasonic trigger settings. For special cases only

Deep ultrasonic trigger settings. For special cases only

Deep ultrasonic trigger settings. For special cases only

AGC low threshold, raise speed (1..10)	15	Deep AGC settings. For special cases only
Speed of amplification increase (1..200)	10	Deep AGC settings. For special cases only
AGC high threshold, raise speed (1..100)	100	Deep AGC settings. For special cases only
Speed of amplification decrease (1..200)	5	Deep AGC settings. For special cases only
Receive window low, m (0..255)	0	TBD
Receive window high, m (0..255)	255	TBD
Minimum distance limitation	enabled	TBD
Auto measurements when radio gaps	enabled	TBD
Filter selection	19 kHz	TBD
RX1 normal	disabled	TBD
RX2 normal	disabled	TBD
RX3 normal	disabled	TBD
RX4 normal	disabled	TBD
RX5 normal	disabled	TBD
RX1 frozen	disabled	Enable/disable sensor RX1 in map building mode
RX2 frozen	disabled	Enable/disable sensor RX2 in map building mode
RX3 frozen	disabled	
RX4 frozen	disabled	
RX5 frozen	disabled	
Additional parameters	(-) collapse	
Obstacles probe	disabled	
File of dump for DAC		

AGC low threshold, raise speed (1..10)	15
Speed of amplification increase (1..200)	10
AGC high threshold, raise speed (1..100)	100
Speed of amplification decrease (1..200)	5
Receive window low, m (0..255)	0
Receive window high, m (0..255)	255
Minimum distance limitation	enabled
Auto measurements when radio gaps	enabled
Filter selection	19 kHz
RX1 normal	disabled
RX2 normal	disabled
RX3 normal	disabled
RX4 normal	disabled
RX5 normal	disabled
RX1 frozen	disabled
RX2 frozen	disabled
RX3 frozen	disabled
RX4 frozen	disabled
RX5 frozen	disabled
Additional parameters	(-) collapse
Obstacles probe	disabled
File of dump for DAC	

Enable/disable sensor RX3 in map building mode

Enable/disable sensor RX4 in map building mode

Enable/disable sensor RX5 in map building mode

Enable/disable sensor RX1 in map frozen/regular work mode

Enable/disable sensor RX2 in map frozen/regular work mode

Enable/disable sensor RX3 in map frozen/regular work mode

Enable/disable sensor RX4 in map frozen/regular work mode

Enable/disable sensor RX5 in map frozen/regular work mode

TBD

TBD

TBD

Interfaces

Interfaces	(-) collapse
UART speed, bps	500000
Protocol on UART/USB output	Marvelmind
PA15 pin function	SPI slave CS
Raw inertial sensors data	disabled
Processed IMU data	disabled

Speed of UART in hedgehog mode

Type of protocol

TBD

Enable or disable receiving raw IMU data with IMU update rate (100Hz)

Enable or disable receiving IMU+ultrasonic sensor fusion data with IMU update rate (100Hz)

Georeferencing

Georeferencing	(-) collapse
Latitude	N0.0000000
Longitude	E0.0000000

The same as with modem

The same as with modem

Misc. settings

Misc. settings	(-) collapse
Sleep with external power	60 sec no connection

Timeout sleep settings

Hedgehogs pairing



Hedgehogs pairing	(-) collapse
Pairing mode	no pairing

Enable for Paired Beacons feature:
<https://youtu.be/aBWUALT3WTQ>

6.9 Radio frequency band and Carrier frequency

- For devices with HW 433 MHz allowable Radio bands 315 and 433,
- For devices with HW 915 MHz allowable Radio bands 868 and 915, but when using antennas at 433 MHz it is possible to use both 315 and 433 MHz

*Mini-RX beacons and Super-Beacons are 868/915MHz only.

It is possible to change the frequency of radio, but radio performance can be severely degraded. It may be enough for smaller distances, up to 10-20 meters, but not more.

Radio frequency band	433 MHz
Carrier frequency, MHz	433.400

Radio frequency band	315 MHz
Carrier frequency, MHz	315.000

Radio frequency band	915 MHz
Carrier frequency, MHz	919.000

Radio frequency band	868 MHz
Carrier frequency, MHz	869.504

6.10 Different hedgehog colors in the Dashboard

You can choose any color for your hedge, but it still has some permanent colors, which inform you about some tracking issues:

- **Blue** - normal mode and confident tracking
- **Orange** - system provides the best location data possible, but confidence is lower than blue
- **Transparent Blue** - lost radio packets
- **Transparent Orange** – weak ultrasonic coverage

6.11 Different stationary beacons' colors in the Dashboard

Stationary beacons v4.9 can have different ultrasonic frequency. Because of that, they have different colors to make it easy to distinguish it:

-  - 19KHz beacon
-  - 25KHz beacon
-  - 31KHz beacon
-  - 37KHz beacon
-  - 45KHz beacon

7. SW feature/settings descriptions

7.1 Licenses

We added the licenses system. Now, you can order some additional features. It is not available in the basic Dashboard version, but you can easily purchase it if necessary. You can see the list on Marvelmind.com -> [Products](#)

To order:

- Go to Marvelmind.com -> [Products](#)
- Choose features which you want to get (e.g. [MMSW0001: 100Hz NMEA0183](#))

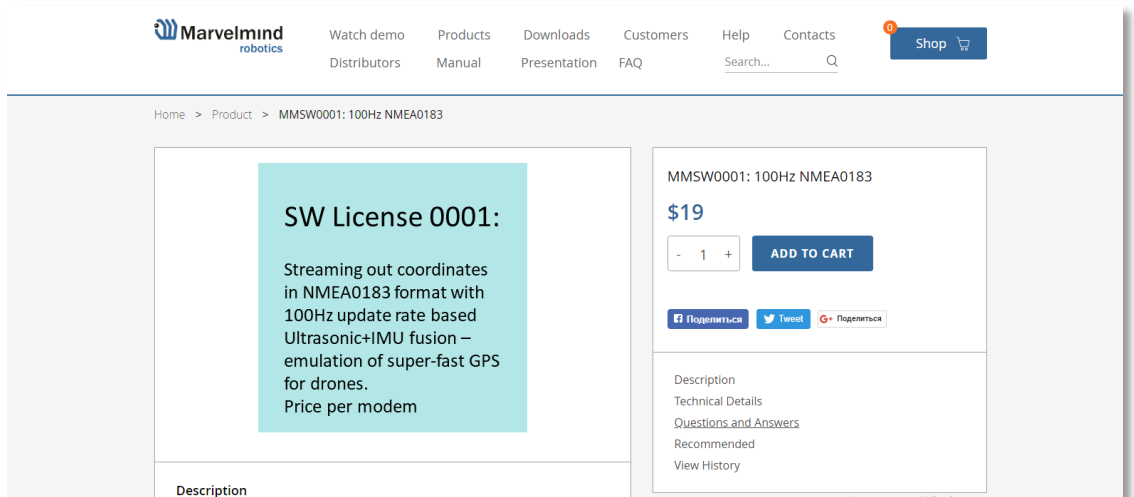

- Make an order.
- Pay for the feature (via PayPal or other methods).
- Order the feature via the Dashboard by providing modem's CPU ID or send us email with the modem's CPU ID:
 - Open Dashboard SW
 - Connect modem to the Dashboard via USB
 - Go to **Licenses** → **View/activate licenses**

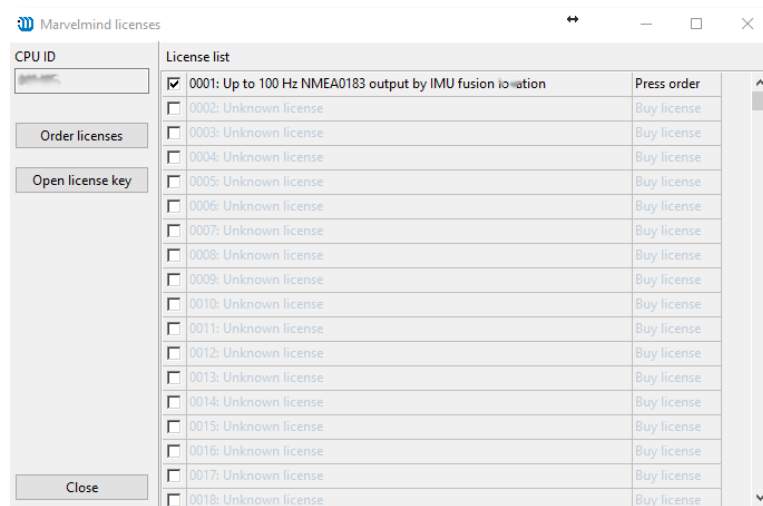

- Choose the licenses which you have purchased.
- Press Order licenses.

- Dashboard will generate a text

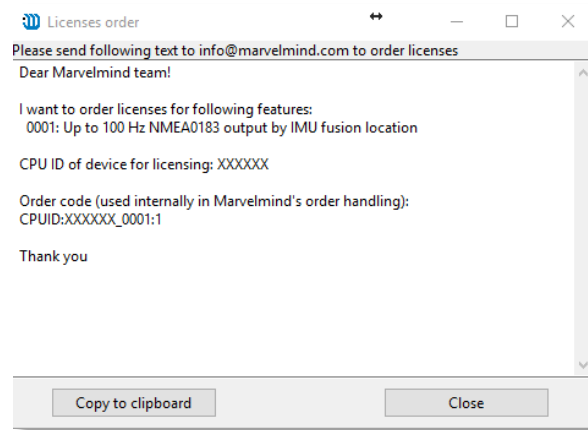

- Send generated text to info@marvelmind.com
- We will generate the license key and send to you via email
- Place the license key into Dashboard/Licenses folder:
 - Connect modem to the Dashboard via USB
 - Go to **Licenses** → **View/activate licenses**
 - Choose "Open license key"
 - Choose the license file (be careful if you have licenses for multiple devices, check CPU ID carefully)
- The features become activated in the Dashboard.

7.2 Dashboard Monitoring Mode

Dashboard Monitoring Mode is a mode which allows you to observe tracking without any ability to control and modify the system.

Now, you can divide permissions between users for avoidance of accidental change of any settings and corrupting the system. That is something like safety button.

This is the first version of Dashboard Monitoring Mode. New functionality and appearance may come with future SW updates

How to enable Dashboard Monitoring Mode:

- Click on the “Stream capture” button (It will be renamed in future updates into “Dashboard Monitoring Mode”)

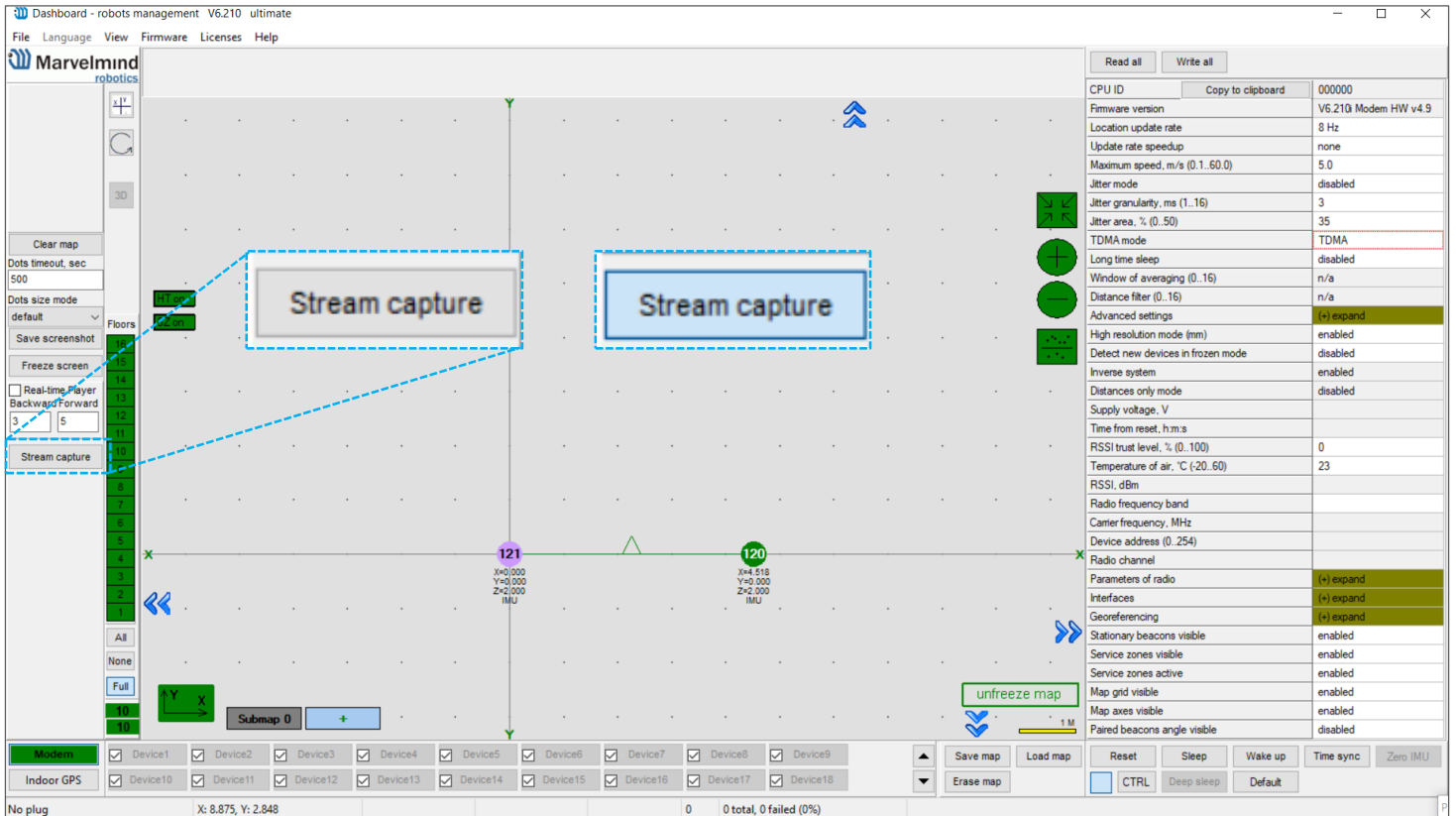

- If you try to change settings while Dashboard Monitoring Mode is on, the notification window will appear

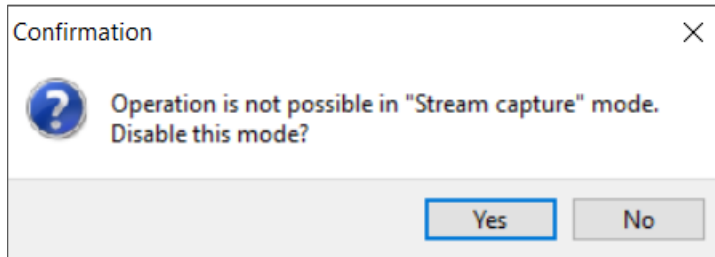

7.3 Geofencing zones

Geofencing zones is a subset of zones which can be created to prevent people crossing dangerous zones. Zones violations leads to alarm and will be written into CSV-file.

How to create geofencing zone:

- Unfreeze map, submap may be frozen

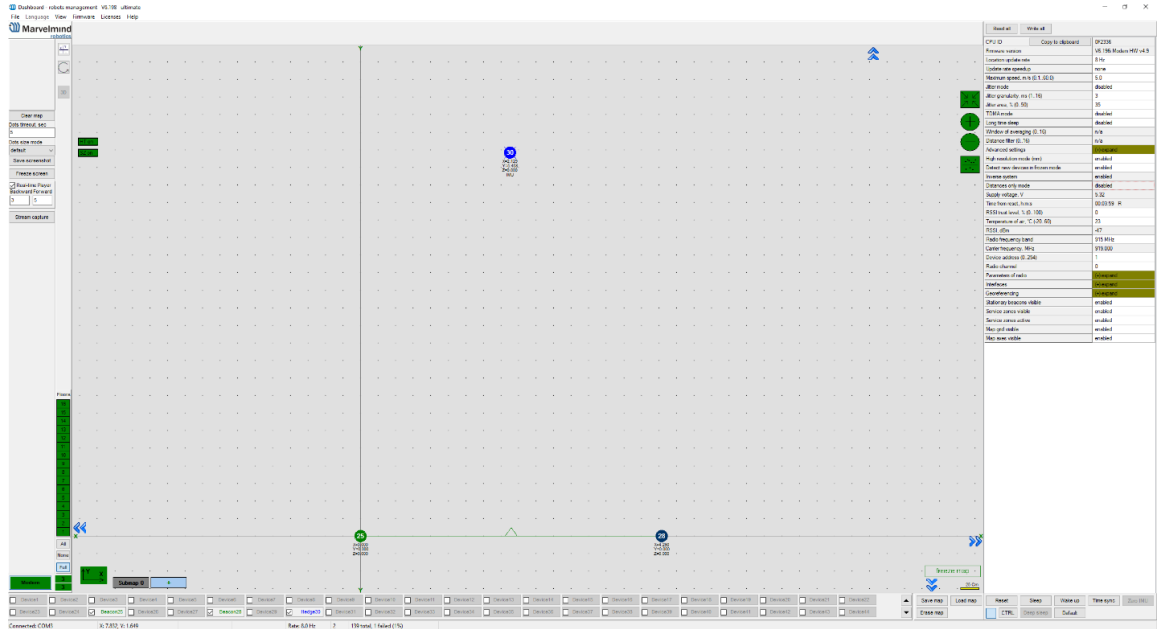

- Choose submap (Left mouse click on its icon) and Right mouse button click on the map -> Zones setup

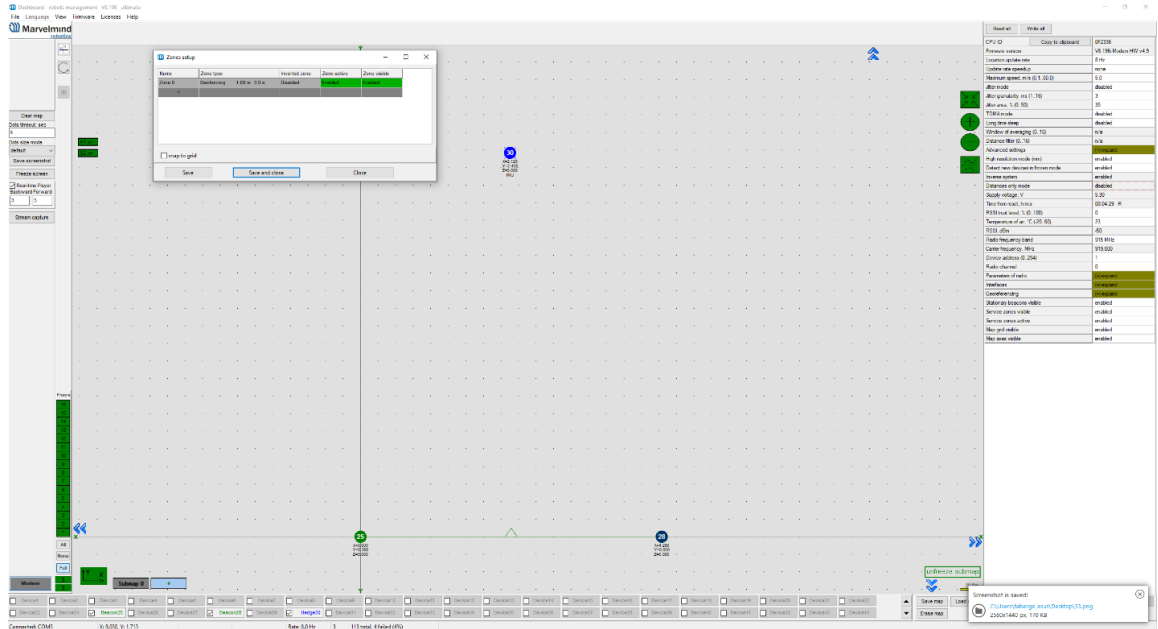

- Create a zone using **Shift+Left mouse click** and clicking on map, click on point removes it

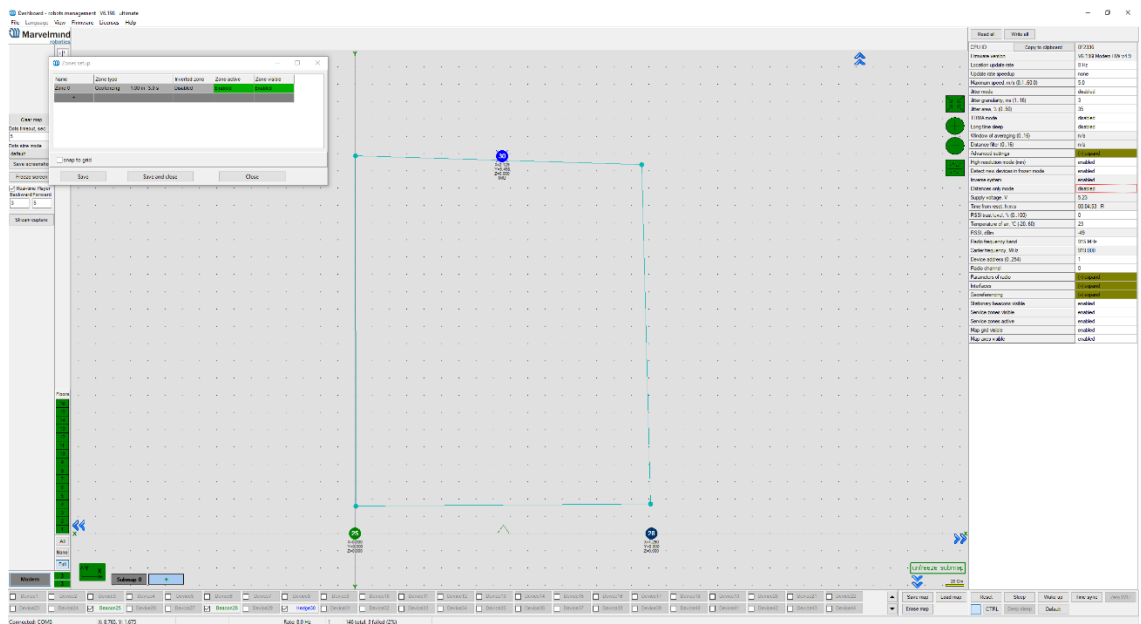

- You can **tune zone with entering distance and entering time**. If zone created, press **Save and close** to save zone

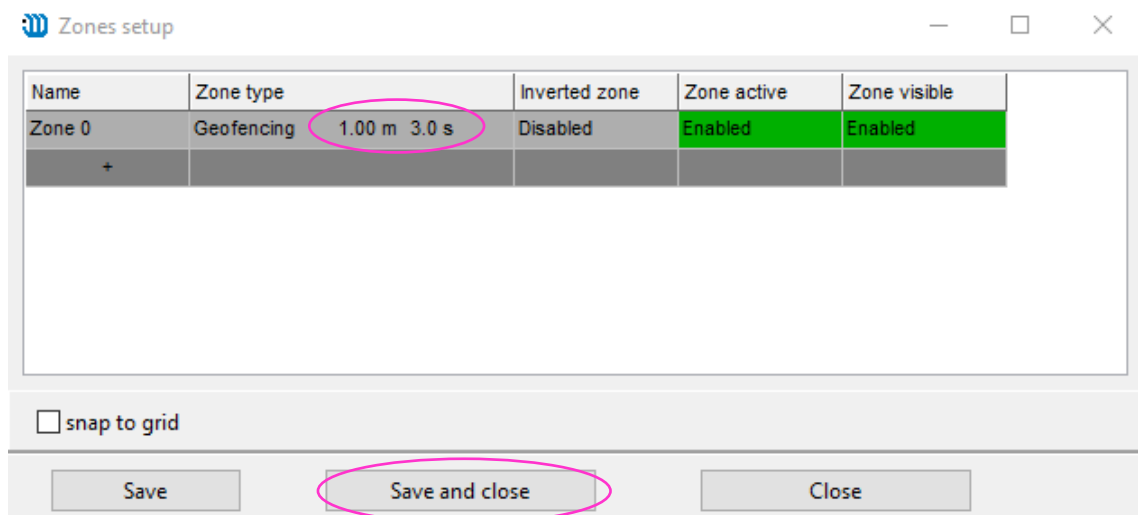

- Freeze map
- Zone created and ready to work. If mobile beacon crosses zone for tuned distance and tuned time, that violation will be recorded to CSV-file, and hedgehog will be colored **red**

7.4 Floors feature (FN0011)

The general view

Floor feature allows to build complicated multi-level maps. Every submap correspond some height, height corresponds to floors.

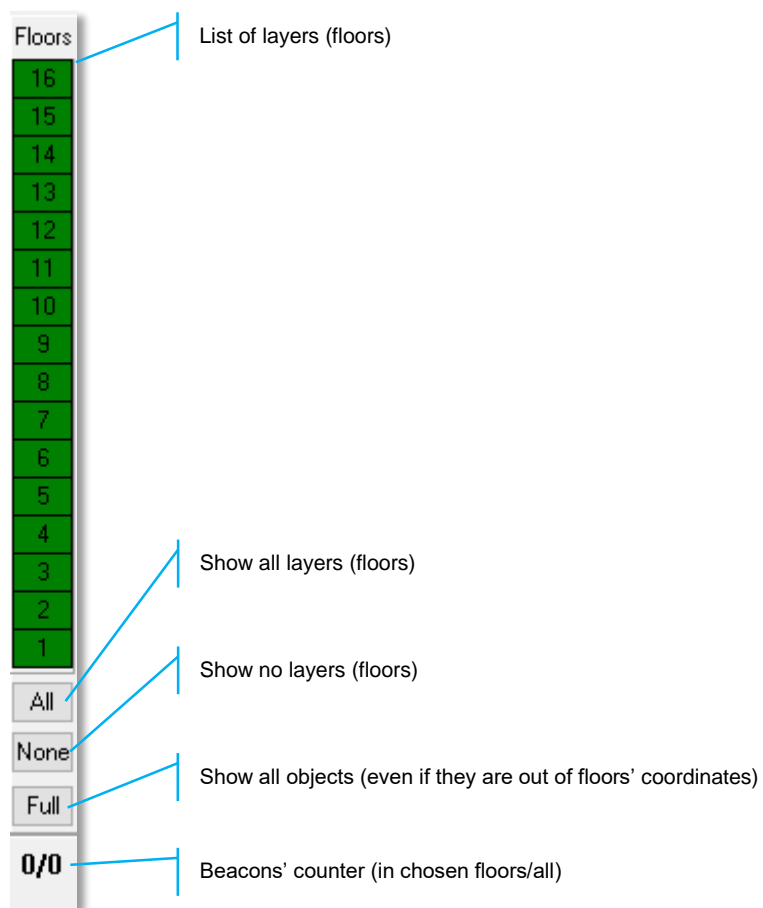

Floor Settings

- Every floor has its own adjustable height and its own floor plan

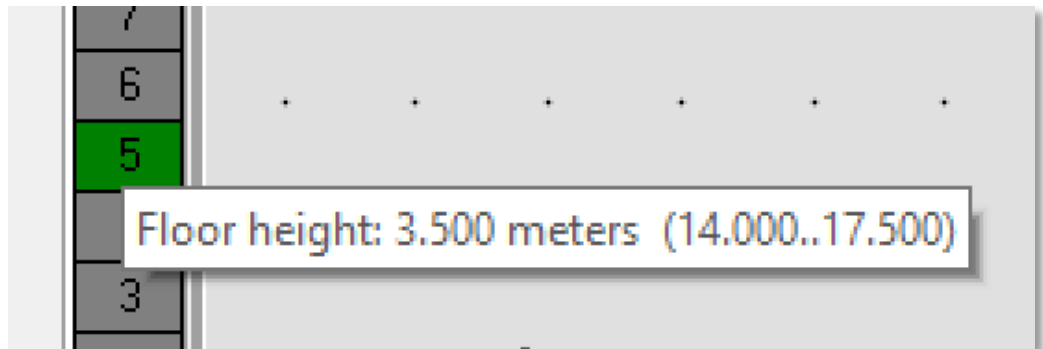

- Use right mouse button on the floor area to see an additional menu. There you can change floor's height. You can also insert your floorplan for that floor (.png, .jpeg, .bmp, .tiff)

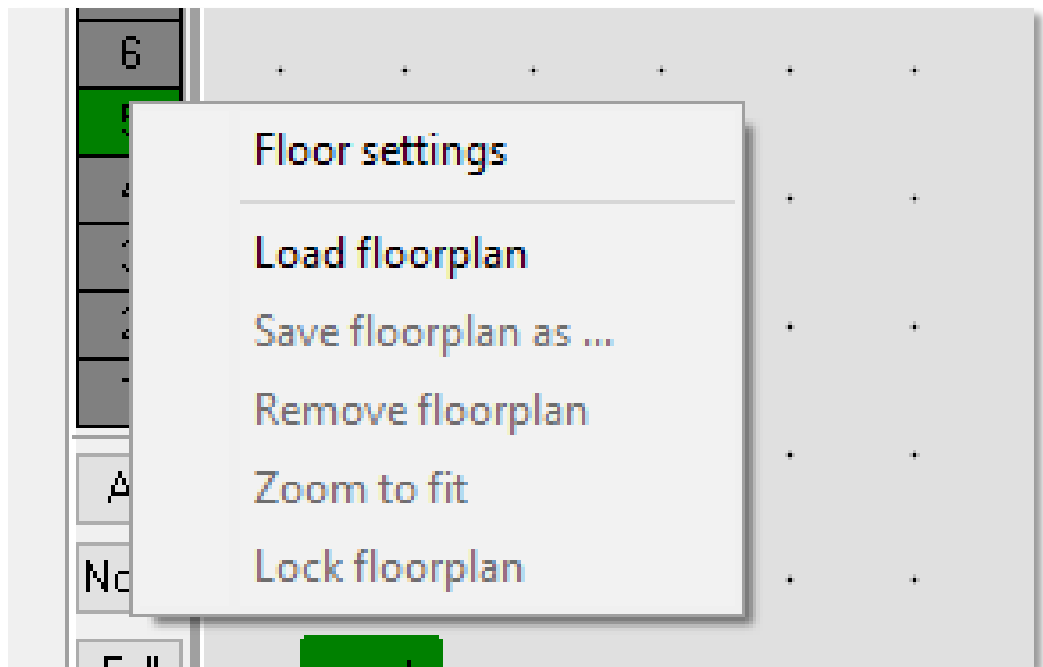

Floor 4 and 5 are enabled:

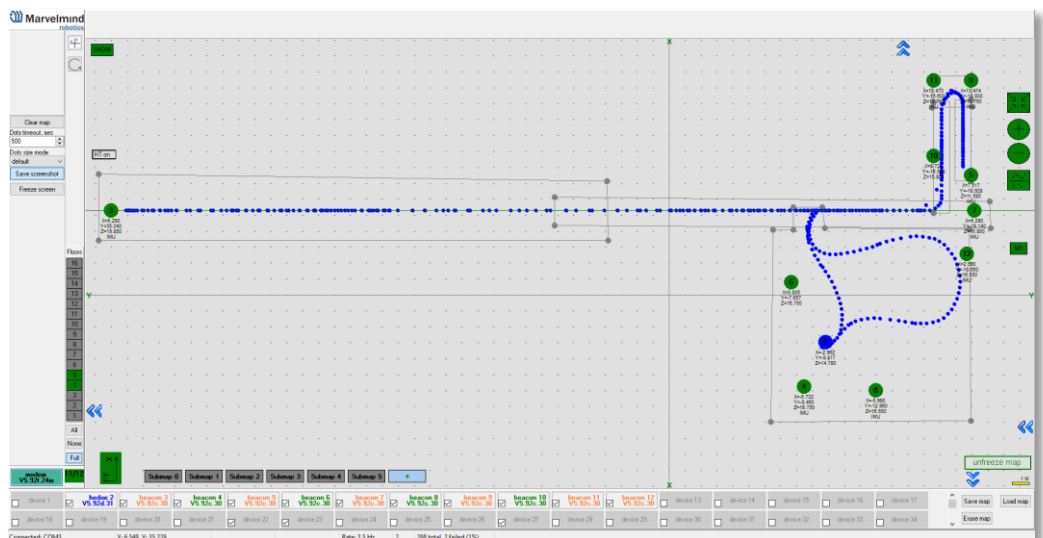

Floor 5 is enabled:



Floor 4 is enabled:

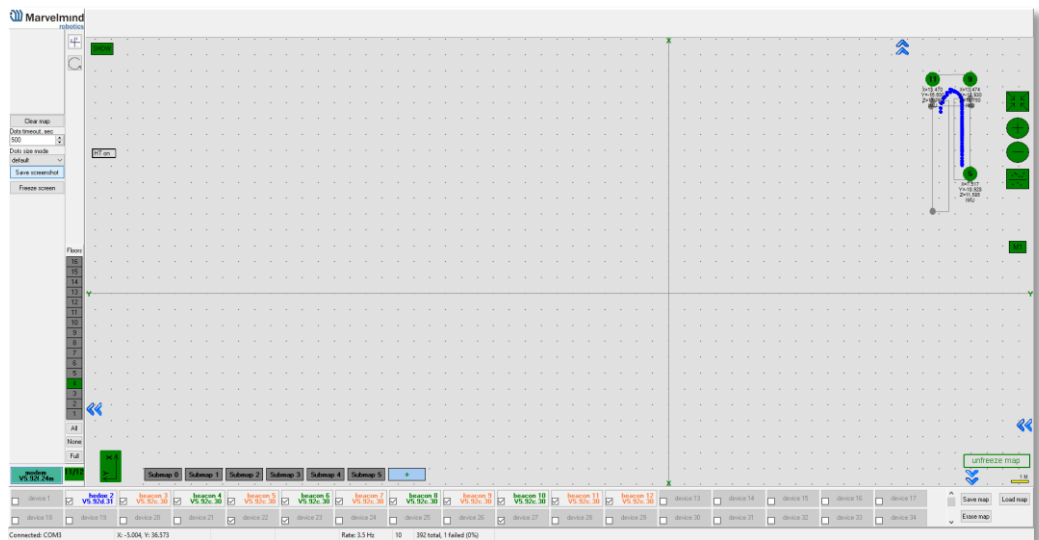

Loading the Floorplan (Substrate)

- Right mouse button click on the floor -> Load floorplan -> Choose file (.png, .jpeg, .bmp, .tiff).

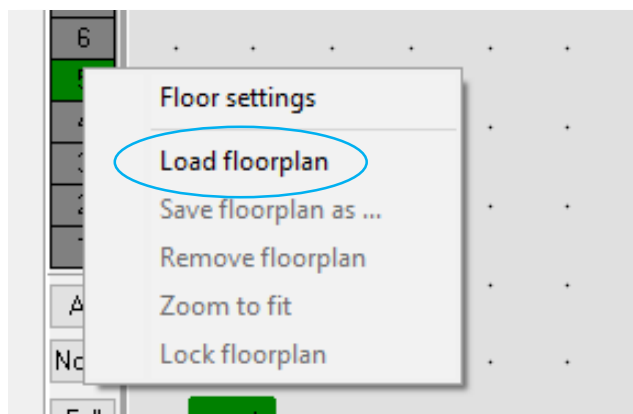

- When the picture is loaded, you can drag the beacons to the points where they are actually located. After dragging two beacons, the picture with beacons will be combined in scale
- Help video: <https://www.youtube.com/watch?v=NHUnCtJIYXc>



7.5 Submap Settings

Every submap has its own settings. To correspond your submap to a certain floor you need to adjust the height:

- To open that settings, use **left mouse button** on the **submap icon** - 
- Change **Submap Z shift** value

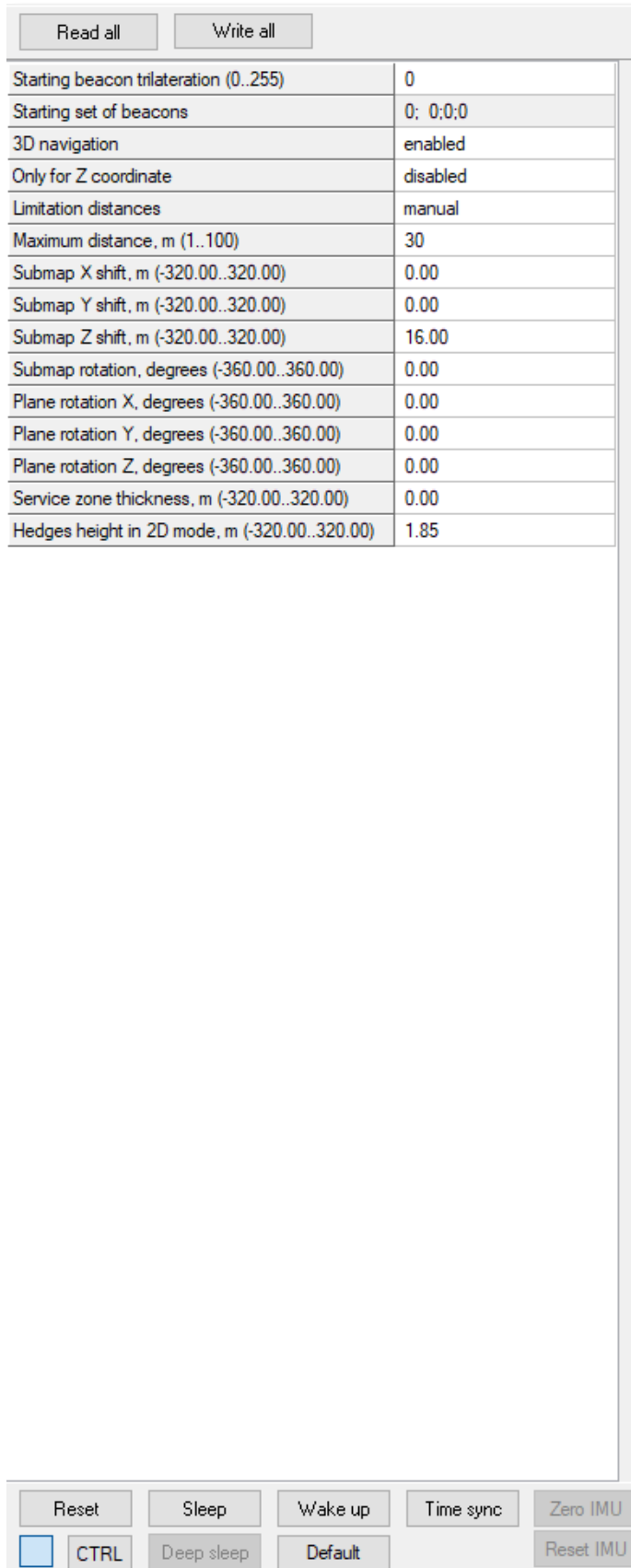

Starting beacon trilateration (0..255)	0
Starting set of beacons	0; 0;0;0
3D navigation	enabled
Only for Z coordinate	disabled
Limitation distances	manual
Maximum distance, m (1..100)	30
Submap X shift, m (-320.00..320.00)	0.00
Submap Y shift, m (-320.00..320.00)	0.00
Submap Z shift, m (-320.00..320.00)	16.00
Submap rotation, degrees (-360.00..360.00)	0.00
Plane rotation X, degrees (-360.00..360.00)	0.00
Plane rotation Y, degrees (-360.00..360.00)	0.00
Plane rotation Z, degrees (-360.00..360.00)	0.00
Service zone thickness, m (-320.00..320.00)	0.00
Hedges height in 2D mode, m (-320.00..320.00)	1.85

7.6 Axis rotation feature (FN0002)

General view

Axis extension allows user to rotate the map. There are 90° gaps between views. It helps in case of multifloor tracking, when it is important to have a side view.

There are 3 directions of view:

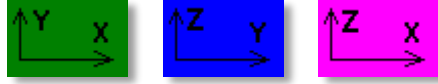

- To change view, click on the icon

Example of views:

Y, X



X, Y

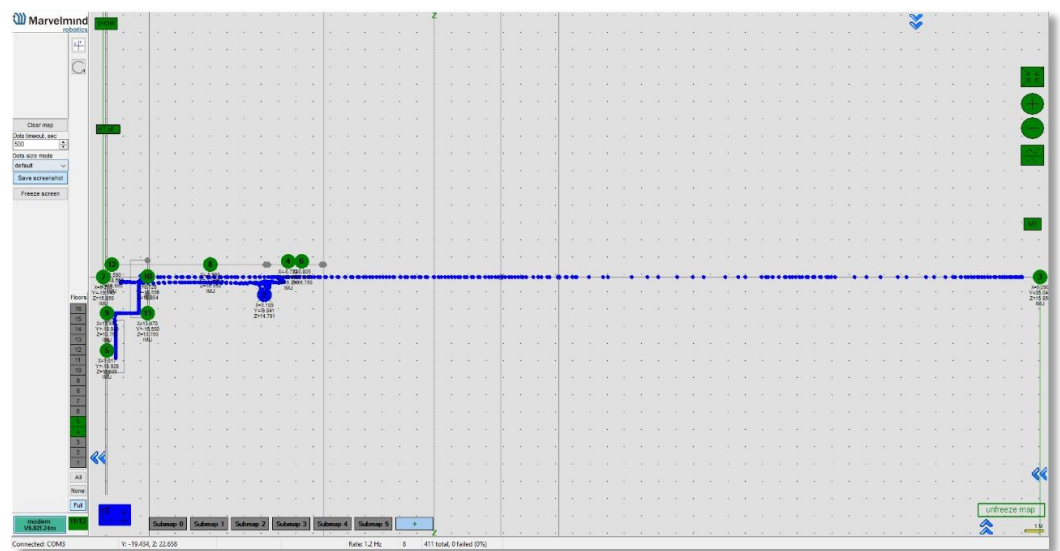

Z, X

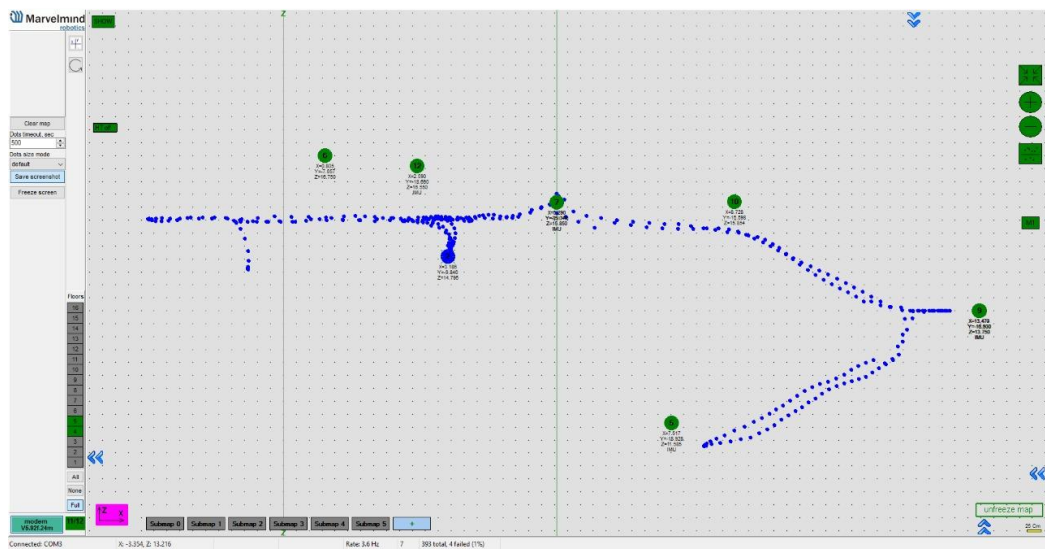

7.7 Vertical submaps feature (FN0003)

Vertical submap is a new feature for drone flights or some other specific cases. It gives the user an opportunity to get solid Z data for vertical movement

Example: The drone flight

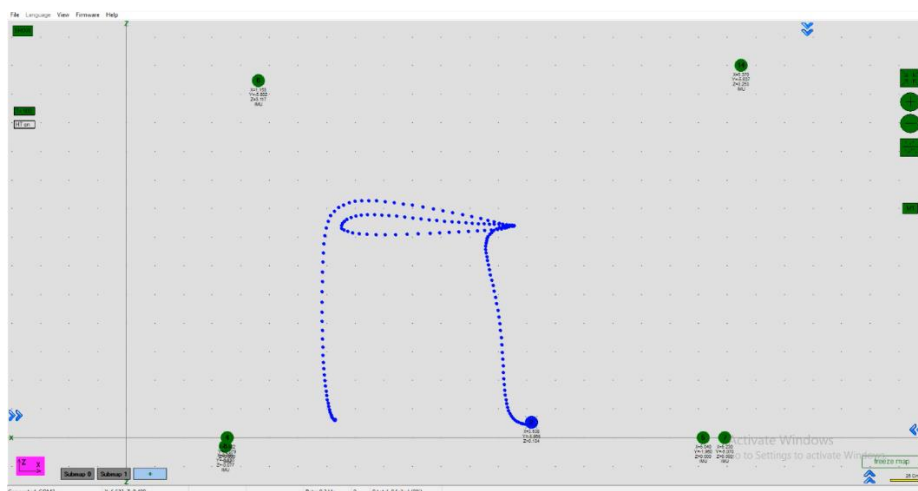
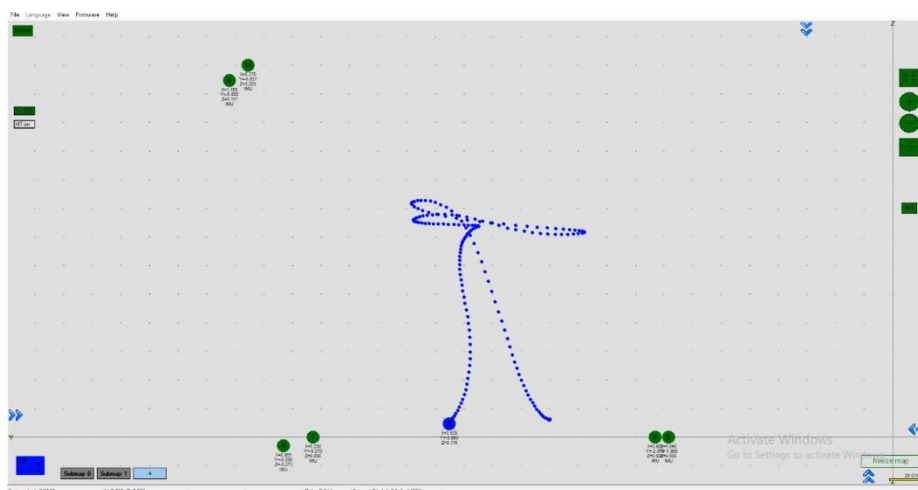
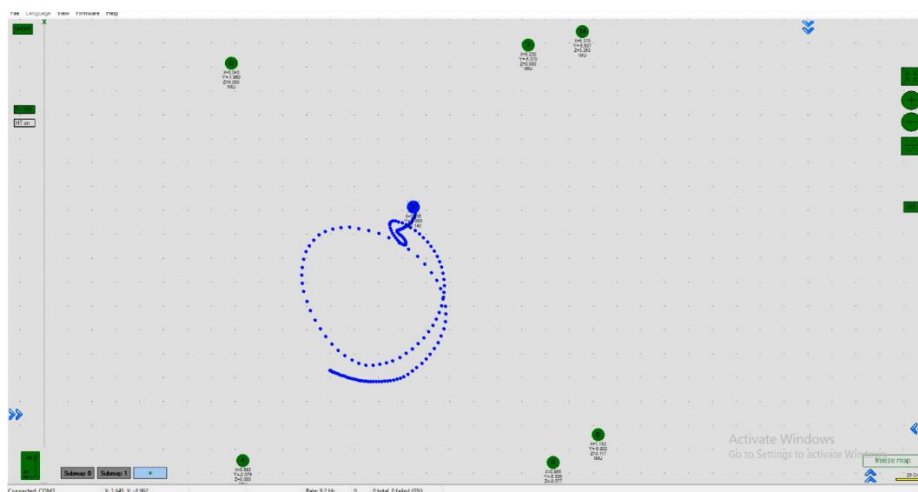

How to build vertical submap for stable Z:

8.5.1 For this configuration you need 6 stationary beacons

- 8.5.2 Place 4 beacons on the ground, facing each other. (make a square, where the edge points are beacons, looking in the center)
- 8.5.3 Place two beacons high on a wall
- 8.5.4 Turn on RX4 only for beacons on the ground and RX4 and RX2 for beacons on the wall
- 8.5.5 Build the first submap (horizontal) consisting of all ground beacons
- 8.5.6 Change **Limitation distance** to **manual** and input the value in the submap's settings

Read all		Write all	
Starting beacon trilateration (0..255)		0	
Starting set of beacons		6; 7;0;0	
3D navigation		enabled	
Only for Z coordinate		disabled	
Limitation distances		manual	
Maximum distance, m (1..100)		12	
Submap X shift, m (-320.00..320.00)		0.00	
Submap Y shift, m (-320.00..320.00)		0.00	
Submap Z shift, m (-320.00..320.00)		0.00	
Submap rotation, degrees (-360.00..360.00)		0.00	
Plane rotation X, degrees (-360.00..360.00)		0.00	
Plane rotation Y, degrees (-360.00..360.00)		0.00	
Plane rotation Z, degrees (-360.00..360.00)		0.00	
Service zone thickness, m (-320.00..320.00)		0.00	
Hedges height in 2D mode, m (-320.00..320.00)		0.00	

- 8.5.7 Freeze and lock it



- 8.5.8 Build the second submap (vertical) horizontally consisting of two wall beacons and two ground beacons (neighboring with wall beacons)

- 8.5.9 Now, freeze it

- 8.5.10 Press axis rotation button 

- 8.5.11 Click on the axis you want to rotate your submap along (when you point the cursor on the axis, it became visible and pink-colored)

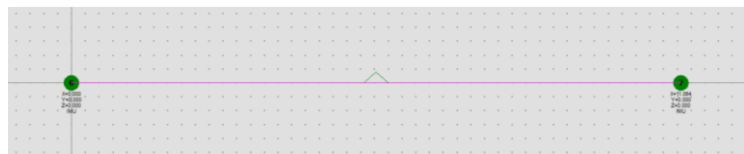

- 8.5.12 Enter the corner value (90° usually)

Enter rotation angle

OK Cancel

8.5.13 Choose submap 2 and enable “Only for Z coordinates” mode

Read all		Write all	
Starting beacon trilateration (0..255)		0	
Starting set of beacons		0; 0;0;0	
3D navigation		enabled	
Only for Z coordinate		enabled	
Limitation distances		manual	
Maximum distance, m (1..100)		25	
Submap X shift, m (-320.00..320.00)		0.00	
Submap Y shift, m (-320.00..320.00)		0.00	
Submap Z shift, m (-320.00..320.00)		0.00	
Submap rotation, degrees (-360.00..360.00)		0.00	
Plane rotation X, degrees (-360.00..360.00)		-88.24	
Plane rotation Y, degrees (-360.00..360.00)		1.15	
Plane rotation Z, degrees (-360.00..360.00)		-0.57	
Service zone thickness, m (-320.00..320.00)		0.00	
Hedges height in 2D mode, m (-320.00..320.00)		0.00	

8.5.14 Change **Limitation distance** value

Read all		Write all	
Starting beacon trilateration (0..255)		0	
Starting set of beacons		6; 7;0;0	
3D navigation		enabled	
Only for Z coordinate		enabled	
Limitation distances		manual	
Maximum distance, m (1..100)		12	
Submap X shift, m (-320.00..320.00)		0.00	
Submap Y shift, m (-320.00..320.00)		0.00	
Submap Z shift, m (-320.00..320.00)		0.00	
Submap rotation, degrees (-360.00..360.00)		0.00	
Plane rotation X, degrees (-360.00..360.00)		0.00	
Plane rotation Y, degrees (-360.00..360.00)		0.00	
Plane rotation Z, degrees (-360.00..360.00)		0.00	
Service zone thickness, m (-320.00..320.00)		0.00	
Hedges height in 2D mode, m (-320.00..320.00)		0.00	

8.5.15 Change views and check the map

8.5.16 Wake up mobile beacon

8.5.17 Track

7.8 Handover Zones Setting

User must setup handover zones between submaps to guarantee handover quality for complex maps with multi-floor and similar.

How to setup handover zones:

- Choose any submap

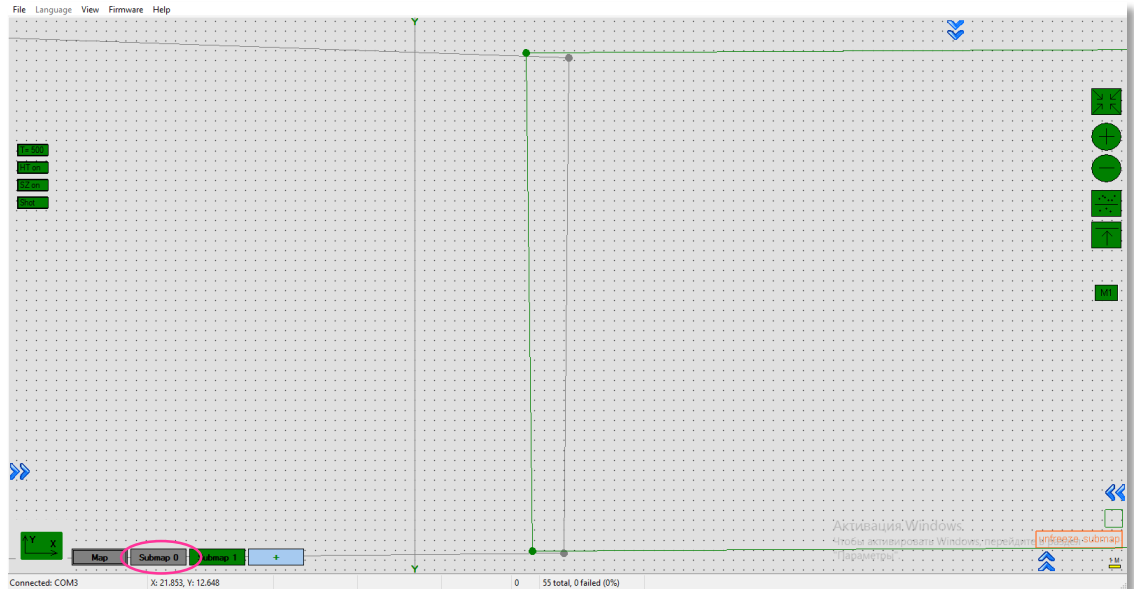

- Use **Alt + Left mouse click** on the other submap's service zone border (neighboring)
- Now, neighboring service zones are colored with green (dark green for chosen submap and light green for neighboring submaps)

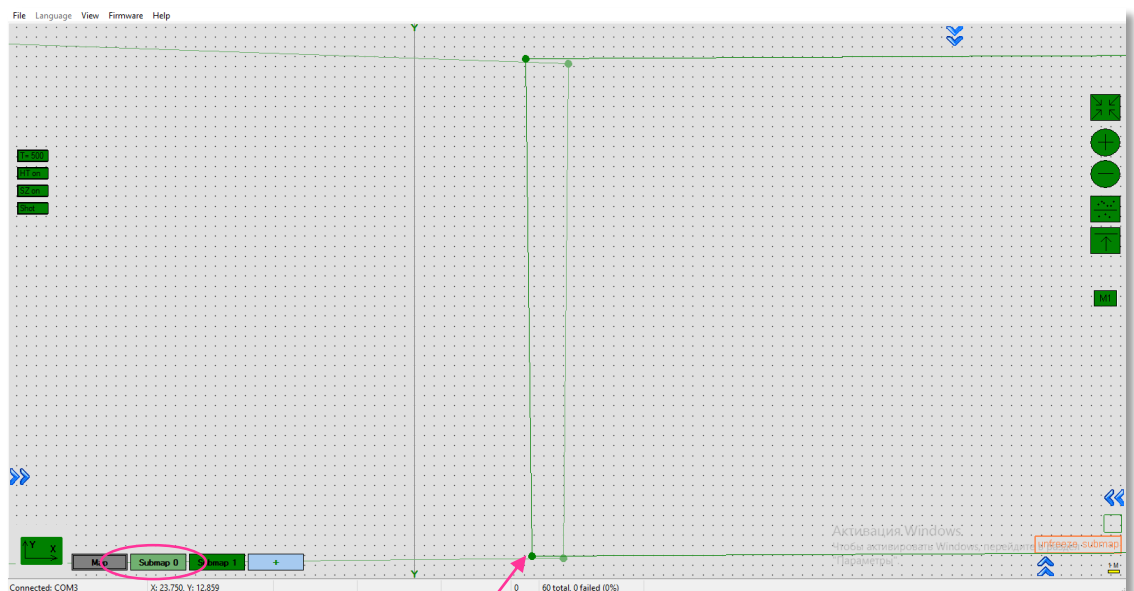

Alt + Left mouse click

7.9 Submaps feature (FN0004)

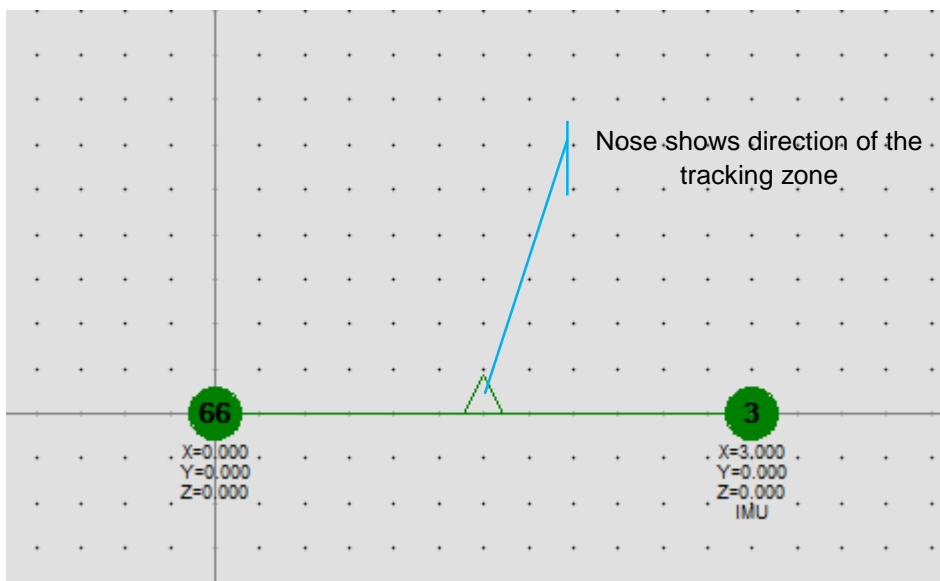

2D submap example

Submaps is a very powerful feature that allows building large maps (full business center, factory, warehouse with total area of 10,000..300,000 or more) based on smaller submaps (30..1000m²).

A submap is a part of the map. It includes a subset of used beacons covering part of the navigation area. Current version of Marvelmind system can include up to 10 submaps. Please also check our [help video](#).



Follow these steps:

- Step 1. Choose the beacons which will be added to certain submap0...submapN
- Step 2. Connect the modem and put all the beacons into sleeping mode
- Step 3. Click "erase map" button for removing some current settings of beacons and submaps
- Step 4. Wake up all the beacons which should be served by submap0
- Step 5. Wait a little for map will automatically build. If needed use mirroring function
- Step 6. Freeze the submap
- Step 7. Add the new submap by clicking "+" button. New submap is automatically chosen as active
- Step 8. Wake up the beacons which should be served by submap1. By default, all the beacons are served by the last unfrozen submap
- Step 9. If the new submap should include beacons which are at the moment served by previous submaps (intersected submaps) click on each beacon, then right-mouse-click=>Add to current submap
- Step 10. If the new submap has 1 or 2 common beacons with previous submaps, it will settle as a part of the already built map. Two common beacons give a tight binding. If there is only one common beacon it's possible to drag and drop the submap. If submaps do not have common beacons it is needed to drag and drop the selected submap using the mouse and holding down the CTRL button. Rotation of submap can be executed by using the mouse wheel
- Step 11. Align submaps using M1/M2 parameter
- Step 12. Set Service Zones for each submap

Starting submaps

- Hedgehogs do not belong to any submap and can move between sub-map areas. Hedgehogs can be served by multiple submaps at the same time. By default, the map consists of a single submap (Submap0)
- After adding new beacons to the system (waking them up), they appear in the first not frozen submap or in Submap0 if all beacons are frozen
- Pressing the “+” button will add a new empty submap to the system

The screenshot displays the Marvelmind robotics software interface. On the left, there is a control panel with buttons for 'clear map', 'Dots timeout' (set to 300), 'save screenshot', and 'freeze screen'. Below these is a 'modem' status indicator showing 'V5.74.24' and '5/5'. The main area is a grid map with several beacons (22, 23, 24, 25, 26) and a hedgehog (26). A table in the top left of the map area shows the following data:

HIDE	22	23	24	25	26
22		10.291	6.598	10.530	
23	10.291		4.890	10.001	
24	6.598	4.890		11.396	
25	10.530	10.001	11.396		
26	11.947	8.250	10.911	3.416	

Below the map is a 'Submap 0' selection panel with a '+' button. At the bottom, there is a status bar showing 'Connected: COM3', 'X: 16.205, Y:-3.870', 'Rate: 6 Hz', and '3'. A list of devices is shown below the status bar, with checkboxes for 'beacon 22 V5.74.30', 'beacon 23 V5.74.30', 'beacon 24 V5.74.30', 'beacon 25 V5.74.30', 'hedge 26 V5.74.31', and devices 27 through 35.

- Press the button with the submap number (Submap0, Submap1 etc.) - select the corresponding submap
- In this state, if the modem button is pushed, the list of parameters on the right side represents some of the parameters of the selected submap, for example, “Starting beacon trilateration,” “Starting set of beacons,” etc.

- The system after adding beacons to the Submap0, adding new submap and the selection of Submap0

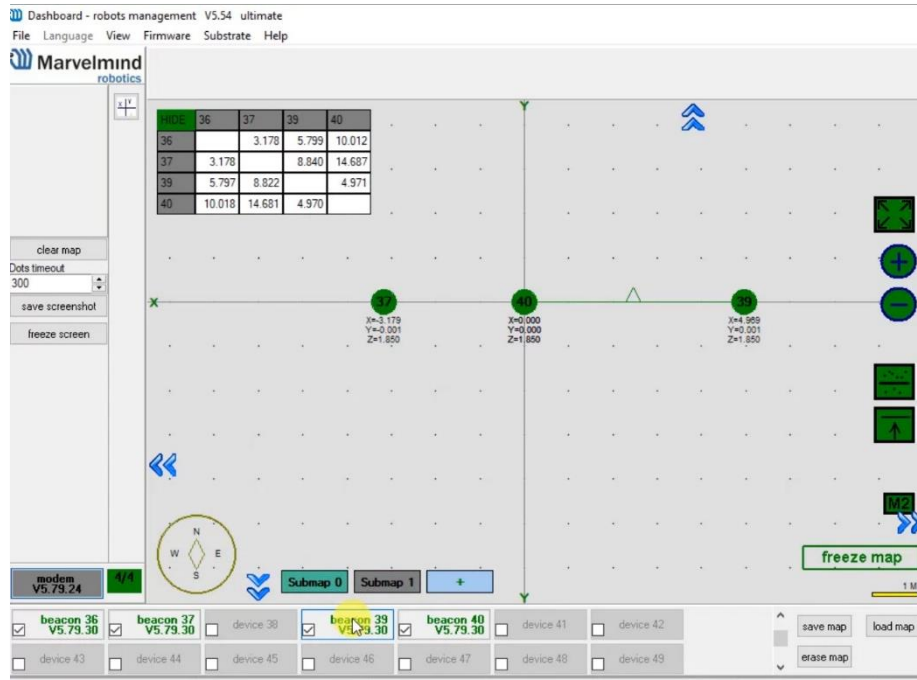

- Now we have 4 beacons, all in Submap0 (it can be seen near the table of distances)
- When the submap selected, the context menu of beacons buttons (available by right clicking the mouse) have the functions of adding and removing the beacons from the submap. In the picture above, we are removing beacon 3 from Submap0." Then we switch to Submap1 and add this beacon to the submap

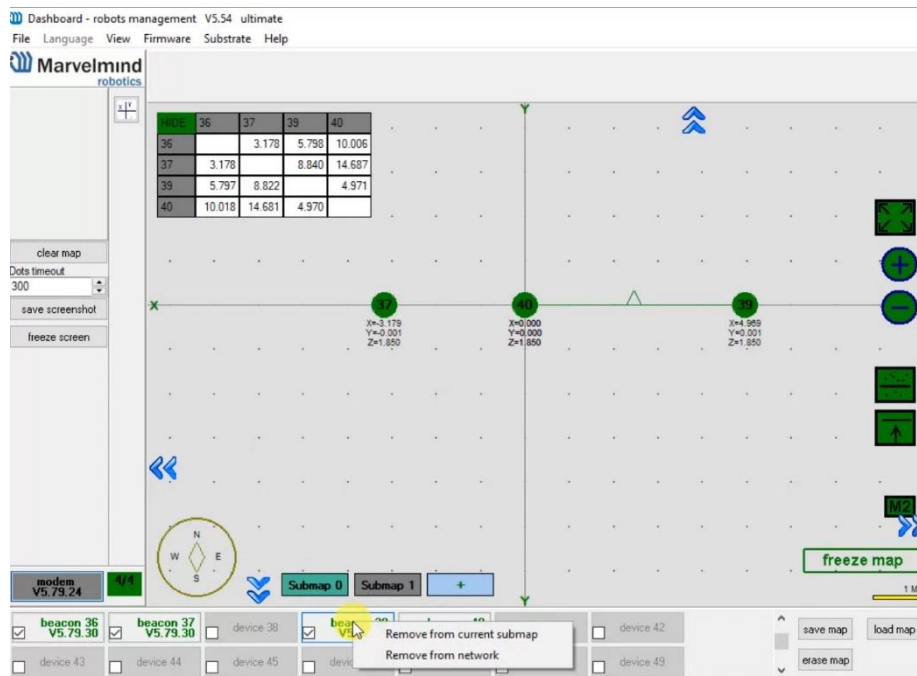

- When the submap is selected, the beacons that do not belong to the submap are colored **gray**. In the same way, continue with removing beacon 10 from Submap0 and adding it to Submap1
- Now there are two beacons in Submap1, so this submap is built. "Submap 0" is built as well. Now we can freeze both submaps

- Pressing the “freeze map” button when the submap is selected will only freeze the selected submap. Pressing the “freeze map” button when the modem button is selected will freeze all submaps.
- Now we have two good submaps, but they are not correctly located relative to each other. On the right side exist the parameters of shift and rotation for the selected submap; they can be filled in by hands. But a more user friendly way is to drag and drop the selected submap using the mouse and holding down the CTRL button.
- Rotation of submap can be executed by using the mouse wheel. The mirroring button can also be used; it affects only submaps that are selected

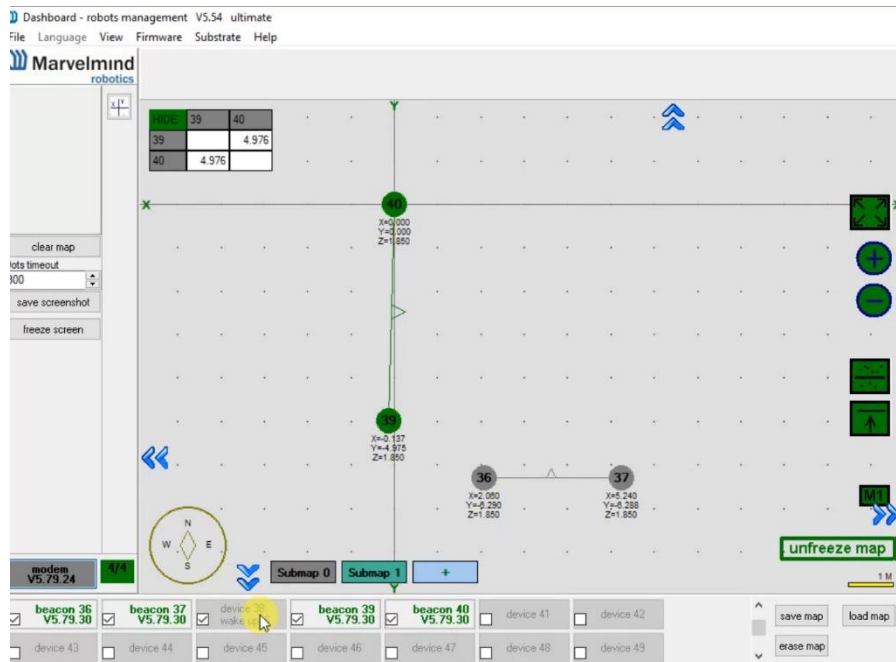

- After some movement, rotation, and mirroring of submaps, we can locate the submaps close to their real relative location
- Now the system is ready to use; we can wake up and track the mobile hedgehog
- In some cases, the hedgehog can be lost between the submaps if this area is not covered by any of the submaps.

- Submaps can be removed from the system by using the context menu of the submap selection button (available with a right mouse click) M1/M2 parameter used for precise superposing submaps which do not have common beacons. This means that submaps cannot be aligned automatically

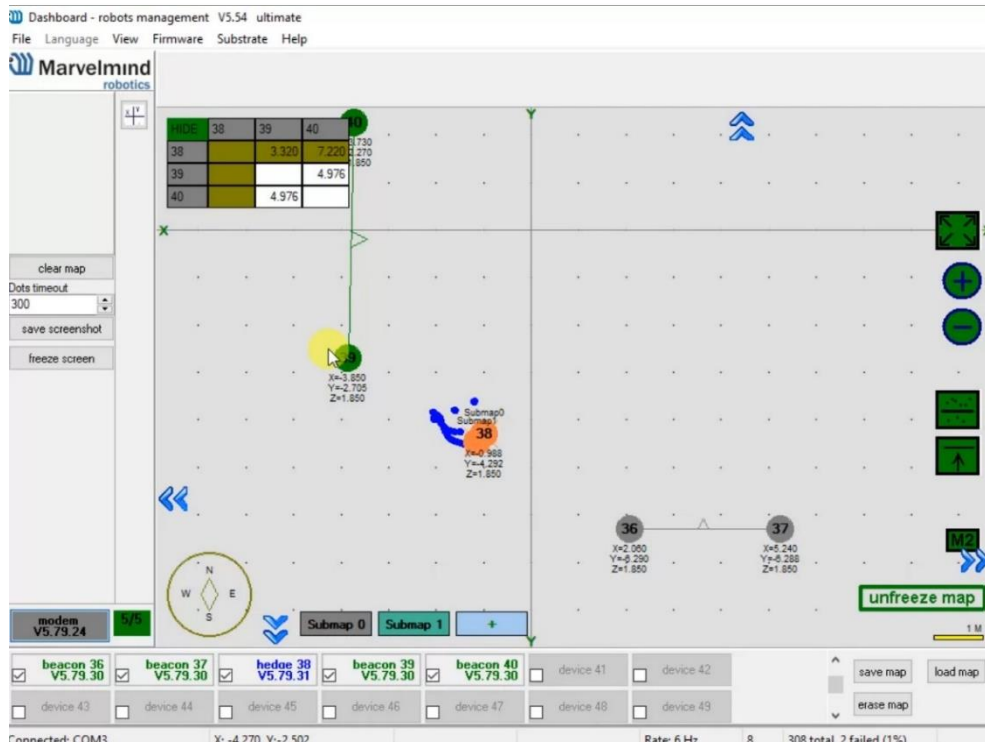

To align submaps:

1. Build the system like in previous instruction
2. Put M2 in mode on by clicking the icon. Place the hedgehog near the boundary between two submaps. You will see 2 orange hedgehogs blinking, this is how the hedge is seen in two submaps
3. To align submaps correctly (CTRL + scroll/drag) against each other, until the orange mobile beacons are fully overlapped
4. Replace hedgehog to 1 or 2 points and repeat replacing submap for better superposing

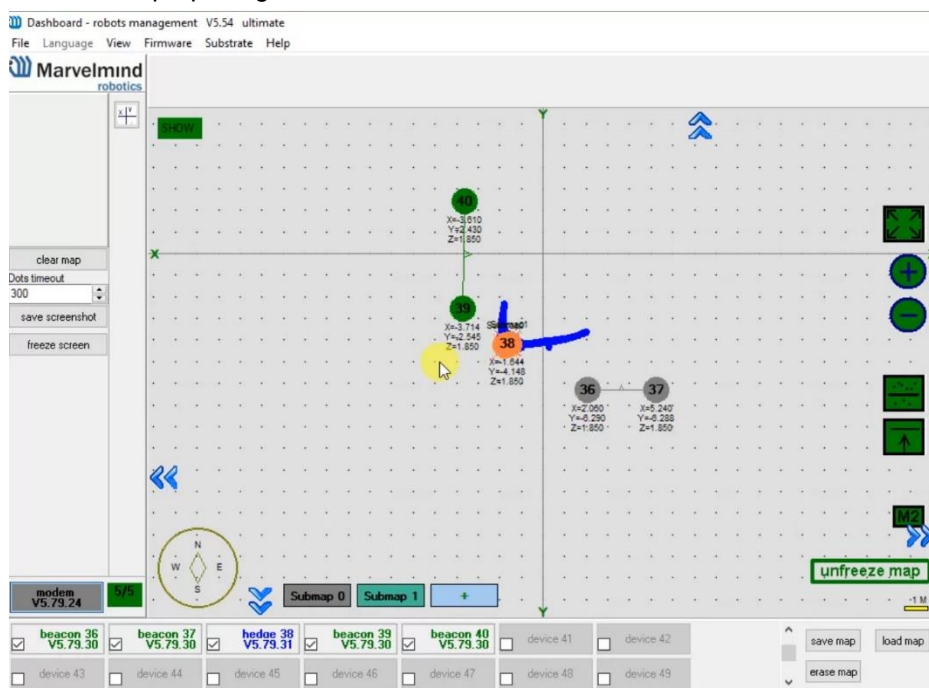

- The next step is to set Service zones, which are zones where tracking is possible. If a mobile beacon is out of a service zone it cannot be tracked. If you built a complicated map, you have to make service zones correctly. Service zones must be crossing in order to provide correct and glide tracking.

How to create a service zone:

- Choose submap (click on the submap icon)
- Use **SHIFT + Left mouse button** on the map to create point.

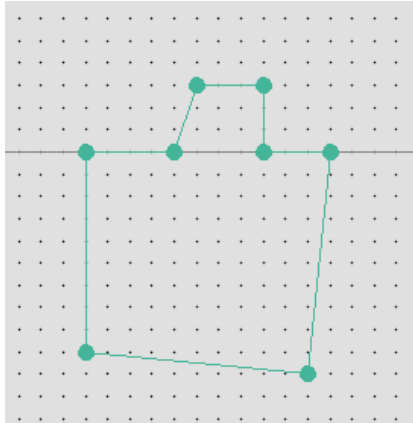

- Use **SHIFT + Left mouse button** on the point to delete it.

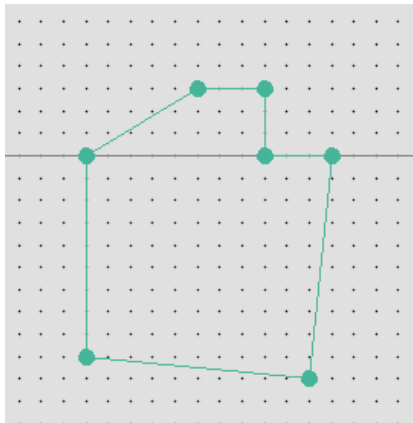

- Put points around submap, move them to provide service area for current submap. Service areas will cross each other. If hedgehogs get lost between two submaps expand the service area.

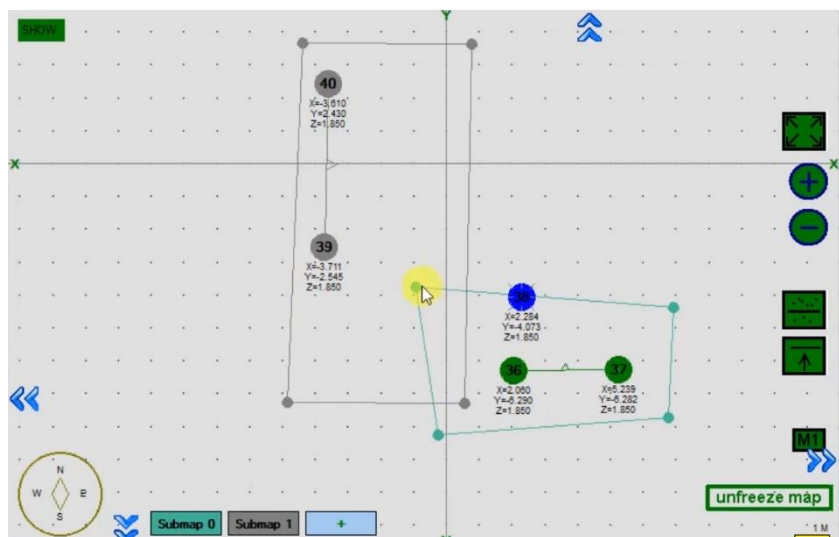

7.10 Paired beacons (FN0005)



- Two hedgehogs can be paired and work together as a single beacon without update rate reduction.
- Moreover, each beacon streams out in this mode not only its own location, but direction where the pair is facing. This feature hugely simplifies autonomous driving and flight. Here is an updated [protocol](#) with the changes.
- Please, also check our [help video](#).

Follow these steps:

1. Wake up stationary beacons and freeze the map
2. Wake up two hedgehogs which were pre-installed on robot/copter/drone
3. Choose one beacon and go to “Pairing mode” parameter and activate
4. Write the “Address of paired beacon”, means number of the beacon, current selected hedgehog is paired with
5. Now choose location against center in parameters relatively the second beacon
6. Go to “Base of the pair” parameter and write actual distance between paired hedgehogs. Do the same for 2nd hedgehog.

hedge	10	15	60	64	70
10			4.532	8.856	
15			4.532	7.042	
60			8.856	7.042	
64			2.123	3.450	7.462
70			2.077	3.380	7.646

7.11 Map settings

Map Settings offer some helpful tools:

- Save map – saves map as *.ini* file into **Dashboard folder/maps**
- Load map – loads map from *.ini* format file
- Erase map – erases map and clears it

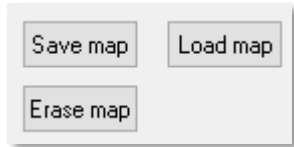

7.12 Background color

Starting from v6.200 Dashboard supports background color change.

This is a small feature that helps make tracking look better. If you uploaded a floorplan and it is white, you can tune Dashboard's background color to make it suit.

How to choose background color:

- Load floorplan

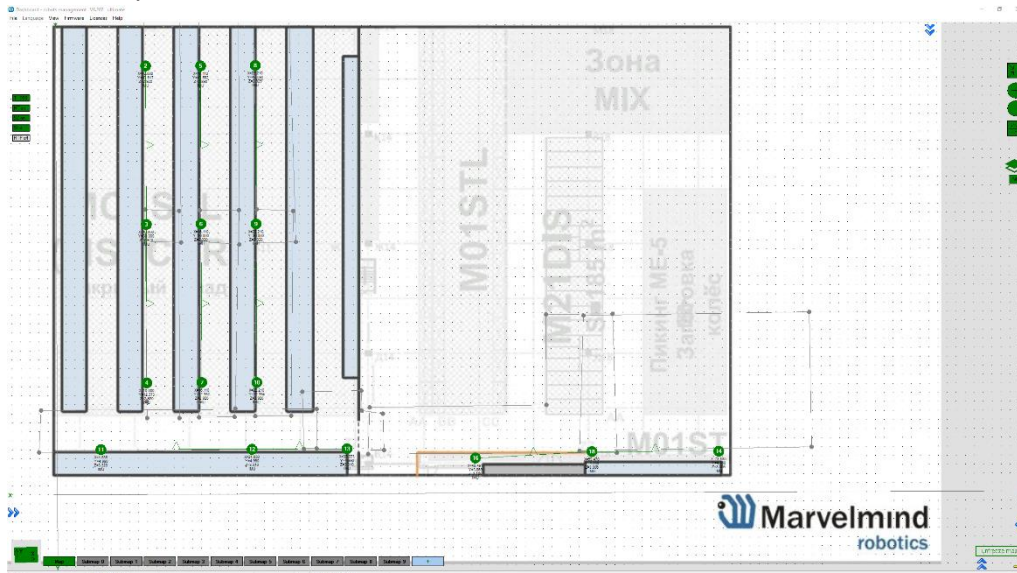

- Right mouse button click on the background

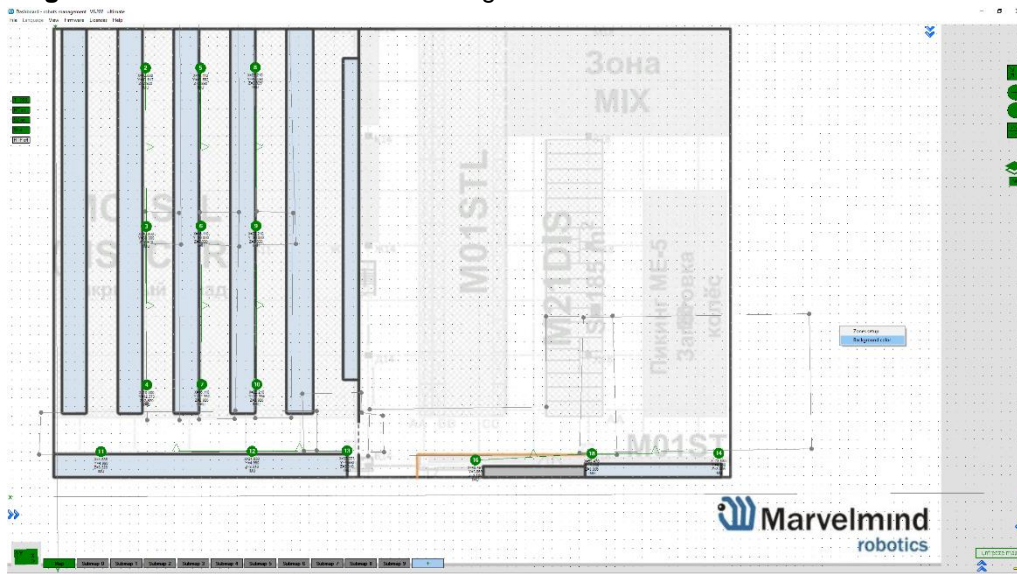

- Choose color and press "OK"

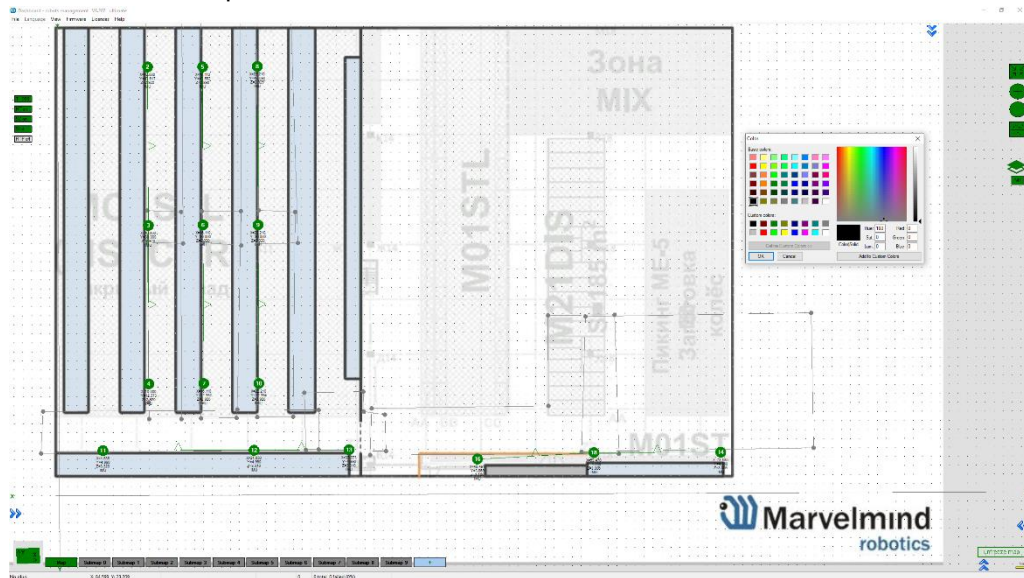

- Color applied. Now, background matches floorplan

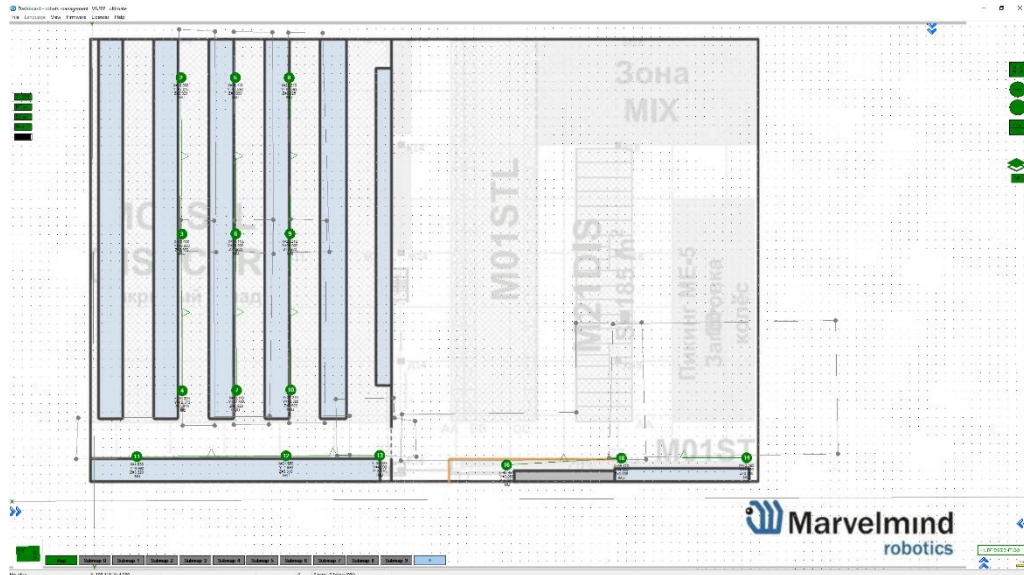

7.13 Hedge color change (FN0006)

If you have multiple mobile beacons you can give each one its own color to make them recognizable on the map

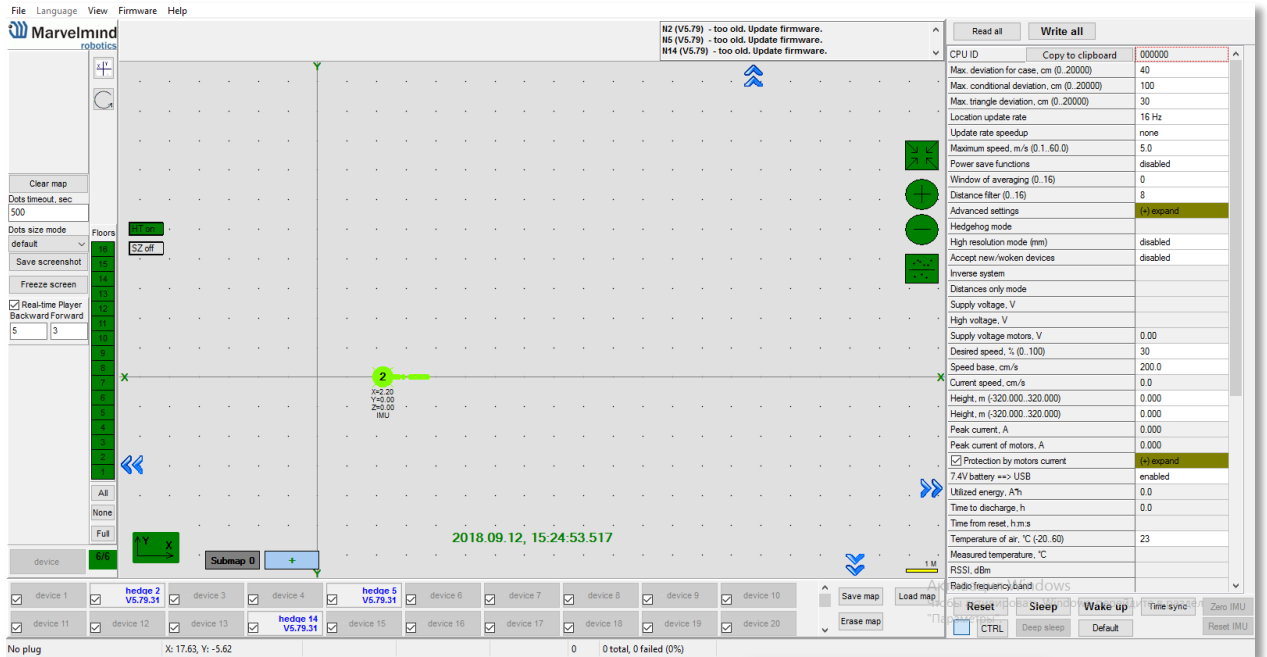

How to change hedgehog color:

- Right mouse button click on the hedge in the list of devices -> **Setup color**

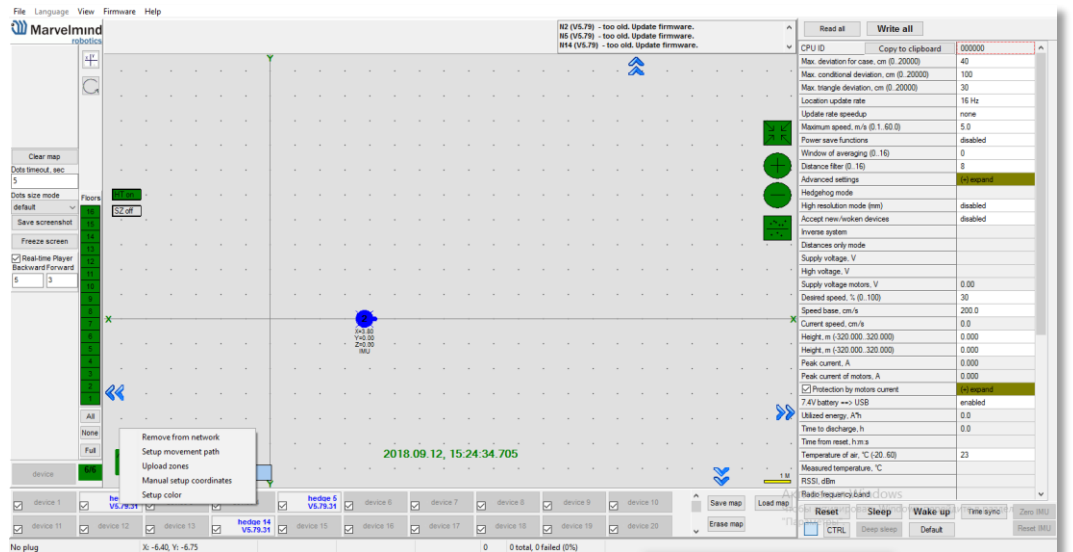

- Choose any color which suits you and press **OK**

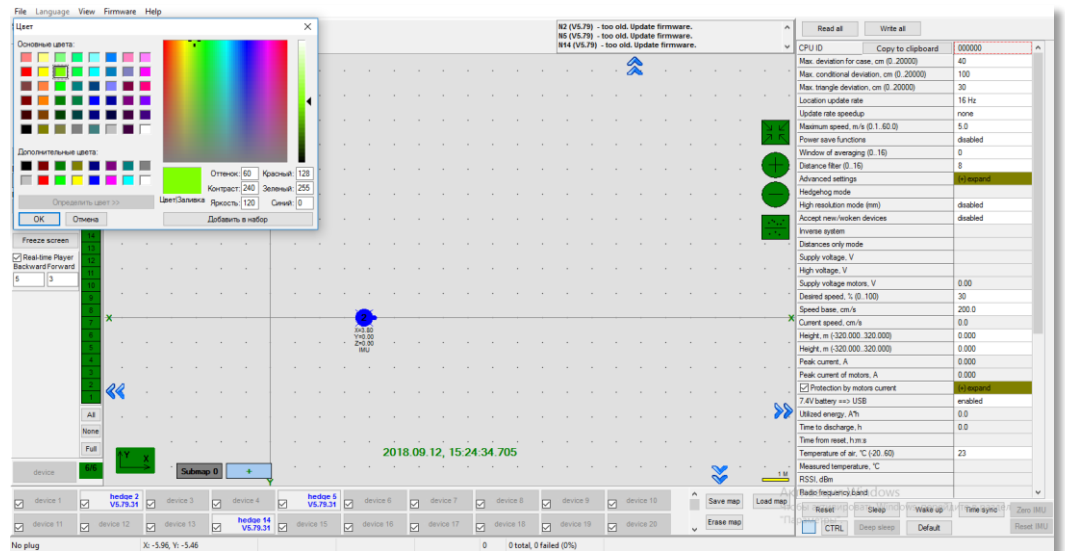

- Now, the hedgehog and its tracking path will be colored

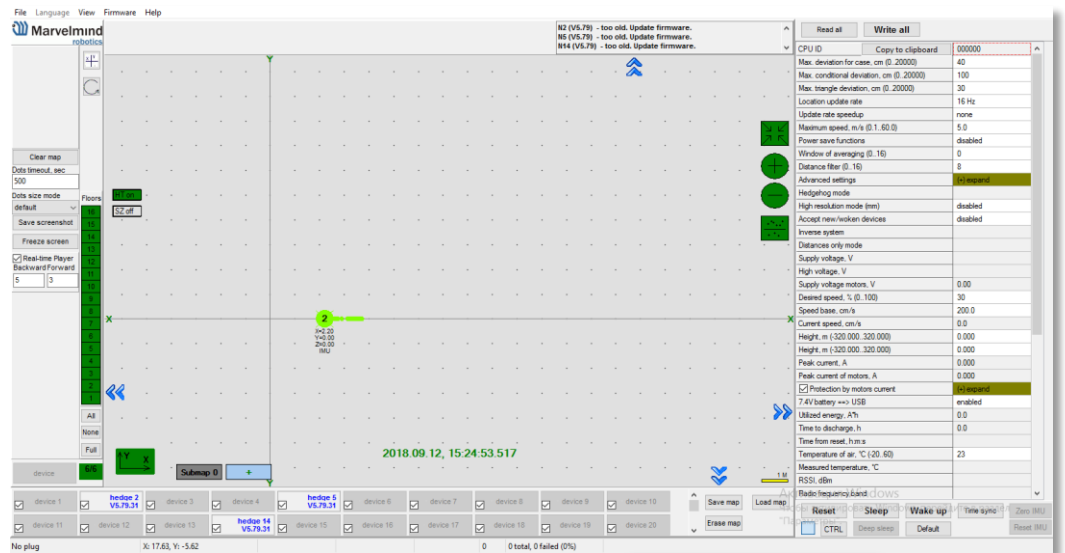

7.14 Payload streaming (FN0007)

- Mobile beacon streaming user payload to modem. See the table with speed vs. payload

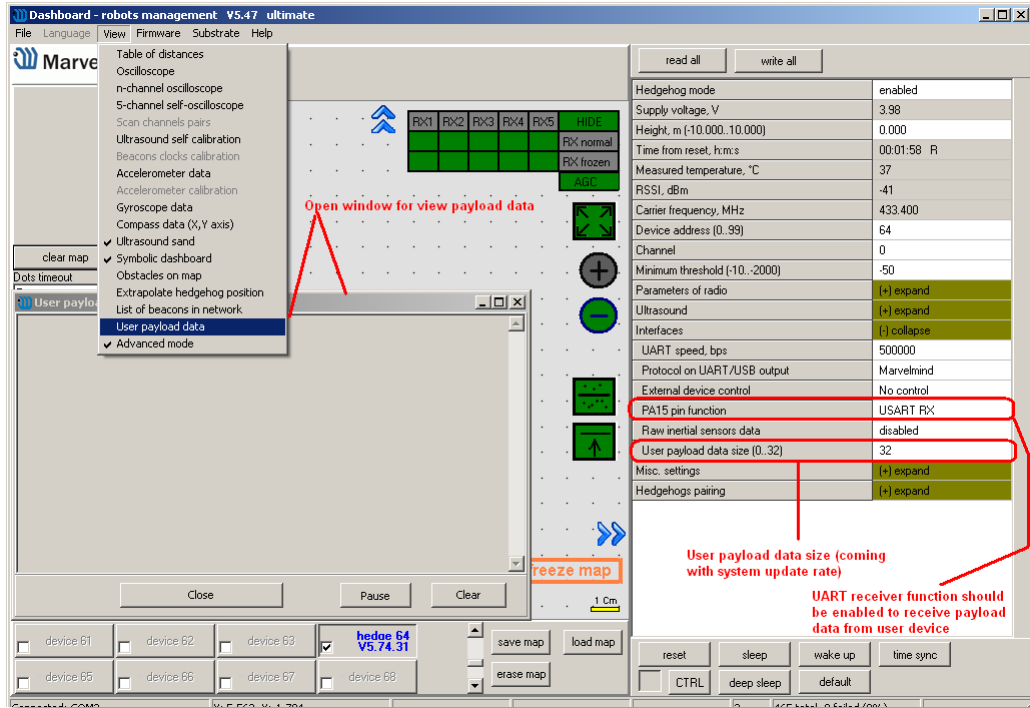

- All measurements were made with update rate setting 16 Hz. Real update rate is limited by distance, position, radio profile and payload data size.

System configuration	Radio profile, kbps	User payload data per cycle, bytes	Real update rate, Hz	User payload maximum data rate (bytes per second)
2 stationary beacons, 3 meters maximum distance	500 (FEC)	0	16	0
		32	16	512
	153 (FEC)	0	16	0
		32	16	512
	38.4 (FEC)	0	9	0
		32	8	256
	38.4 (no FEC)	0	14	0
		32	13	416
4 stationary beacons, 11 meters distance	500 (FEC)	0	14	0
		32	14	448
	153 (FEC)	0	12	0
		32	12	384
	38.4 (FEC)	0	6	0
		32	6	192
	38.4 (no FEC)	0	9	0
		32	9	288

7.15 IMU feature (FN0008)

This function allows to increase data update rate received from ultrasound beacon with IMU due to sensor fusion up to 100 Hz, using inertial sensors (accelerometer, gyroscope).

Required:

- Starter set
- Hedgehog with IMU
- SW and firmware version 5.85 or newer
- Ultrasound Update rate 4Hz or higher

Setup IMU feature:

Accelerometer calibration

- Before you start use the feature check whether accelerometer has been calibrated
- Check if hedge was not calibrated before. Was damaged or fall down
- Put hedgehog on a flat surface (antenna directs up) and connect to your PC. Run the Dashboard

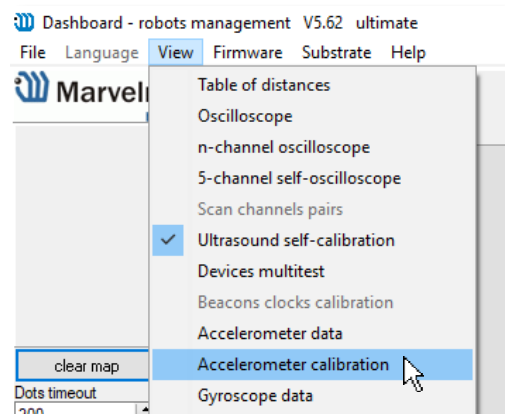

Go to **view => Accelerometer calibration** in open window click **autofill** and **clear table**.

After all values will refresh. Next, click **Pause (shift + space)**

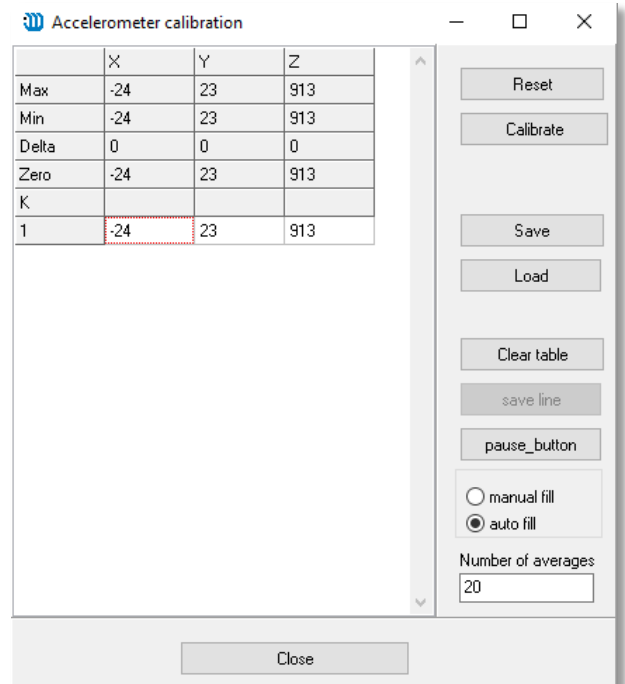

Then take the beacon (hedgehog) and tilt it to each side towards the ground (about 6 times). Rotate a little. You need to achieve x y z values:

- When antenna directs down $z \approx -1000$
=> antenna directs up $z \approx 1000$
- So, one of the axis values always will be $- + 1000$. Others ≤ 10 (preferably less 10, but 25 is also permissible)
- Every time before calibrating the hedgehog click **Pause**
- Accelerometer calibrator will choose the best value for each axe. At the end click **Calibrate** and close the window
- Calibration is needed to determine **g** value for each accelerometer axe

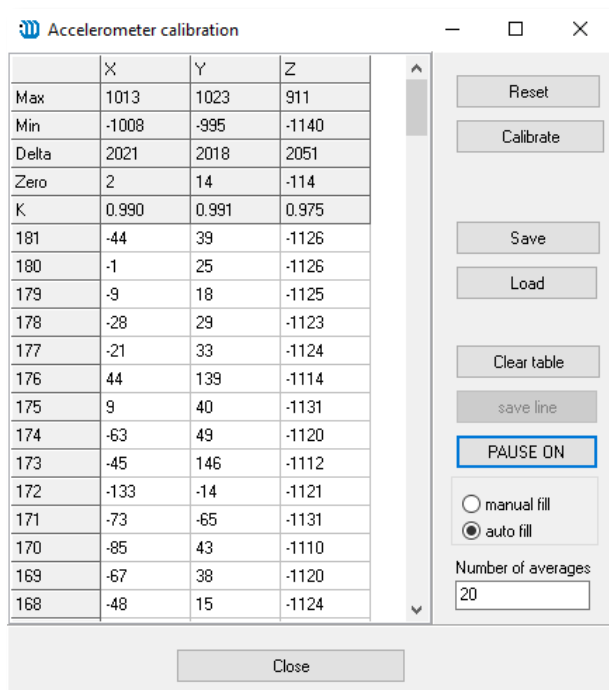

Start the system:

Setup the system as usual. It is described in paragraph [Setting up the system](#).

After the ultrasound tracking has started, select the hedgehog in the Dashboard, go to menu **Interfaces** (on the right) and enable **Processed IMU data**. After that, it is recommended to bring the hedgehog to real estate and press the ZERO IMU button (right-bottom) for additional sub-calibration of the gyro. After 5 seconds the hedgehog will begin streaming the processed IMU data.

Using Data in the Python Library Example:

Description of the protocol for streaming data: (link)

To work with data, you need to use some ready-made library, or develop your own software tools that can work with the described protocol.

Our company provides ready-made libraries for working with IMU in the following languages:

- python (link)
- c ++ (link)
- java (link)

An example with 3D imaging of a path on IMU with a frequency of 100Hz in real time, here: <https://marvelmind.com/pics/marvelmind-imu-tracker.zip>.

7.16 IMU axis positioning

Super-Beacon IMU axis positions

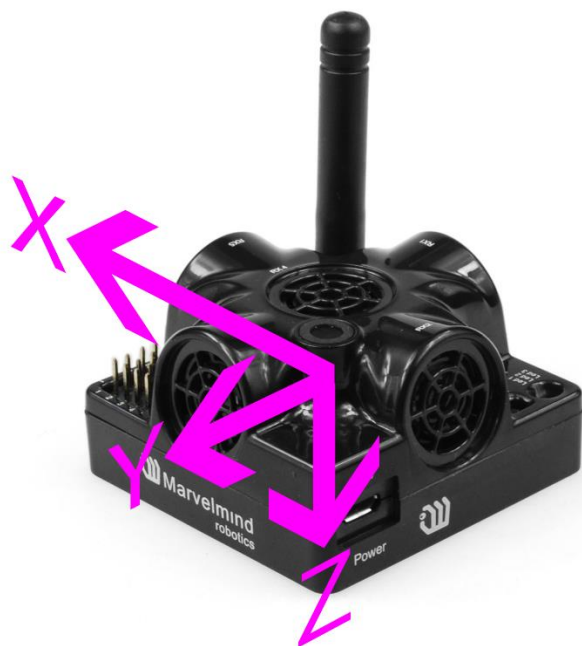

HW v4.9 IMU axis positions



Mini-TX IMU axis positions



Mini-RX beacon IMU axis positions

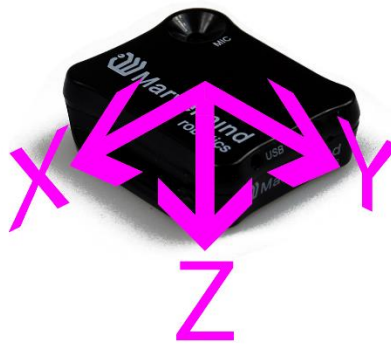

7.17 Player feature (FN0009)

This function is used to view the distance passed, the flight of the copter, etc. The player displays statistics on the maximum and average speed, the path traveled

1. Go to **File=>player**

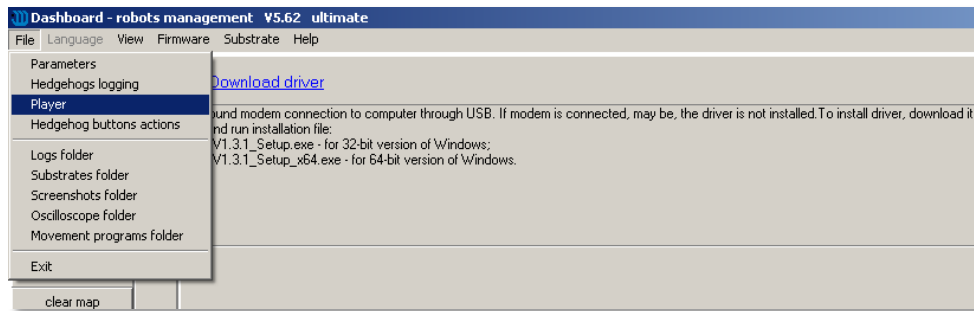

2. This is how the starting player menu looks like

Select log – opens save log file

Play – launch the player

RAW – if clicked, player shows raw data

Smooth – if clicked, player shows smooth data

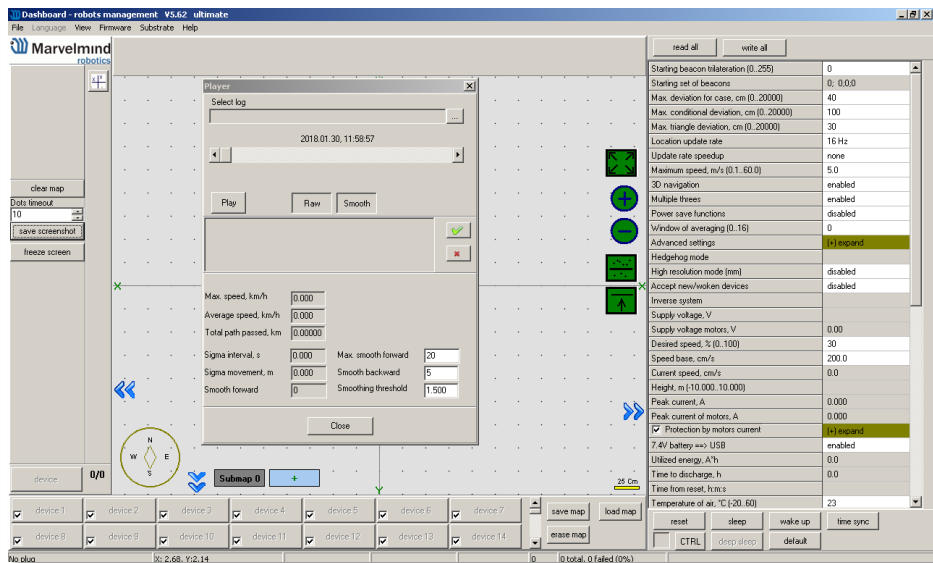

- Now log is loaded. **Important:** for recording log file click **Save map** for saving all the beacons locations and attaching all the beacons to the log

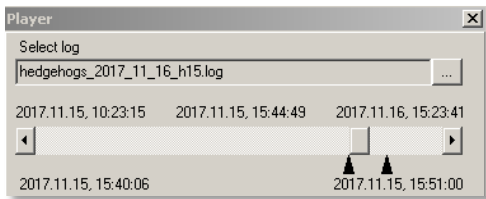

At the top of the player you can see 5 outputs:

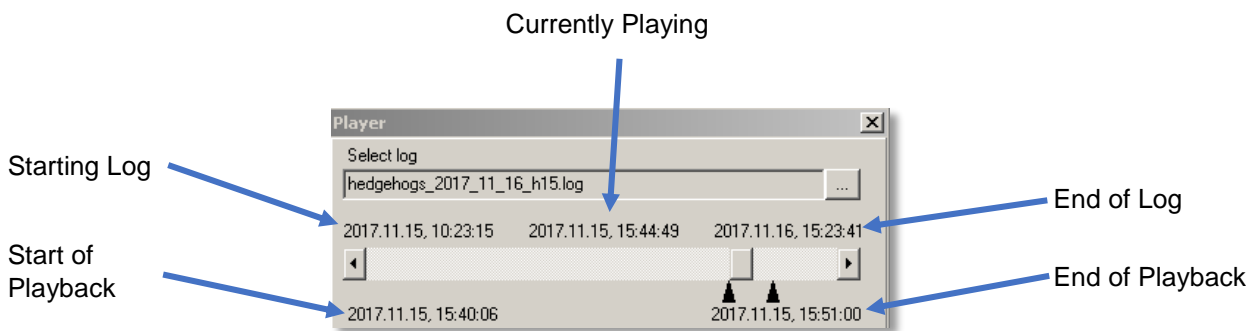

Limited area distance between black triangles under slider. You can move triangles and zoom, place cursor on the slider + mouse wheel. Triangles limit the area in which player works and the statistics is calculated

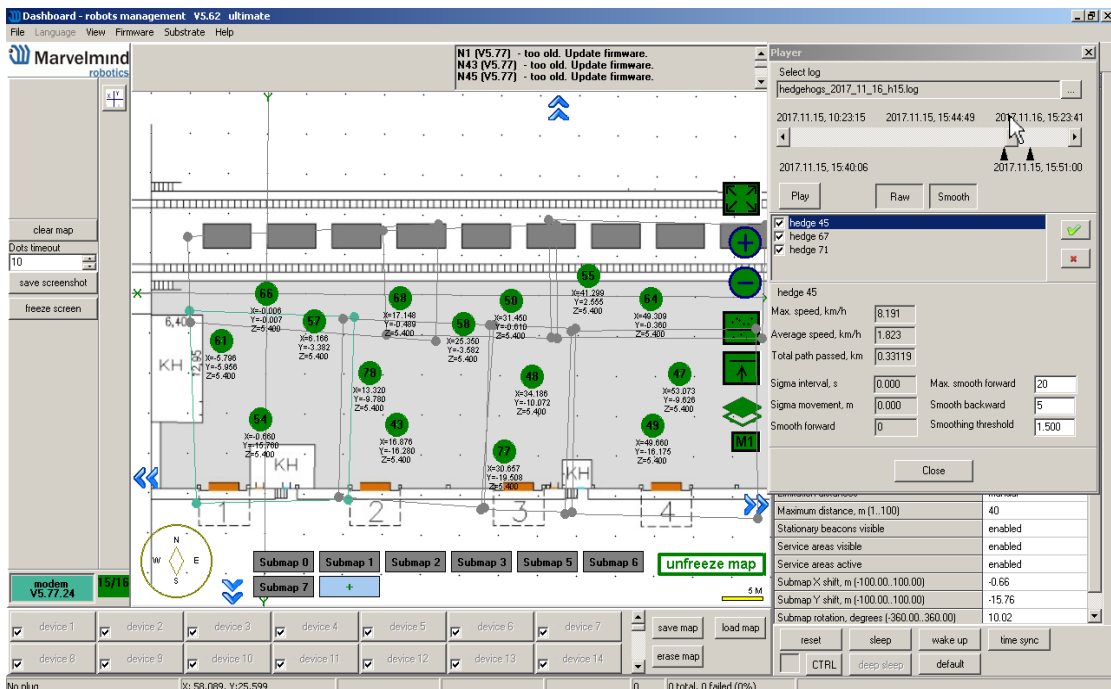

4. In play mode: **grey** points – RAW data, **blue** – Smooth

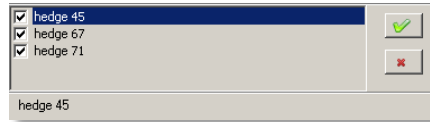

Choose the hedgehog will be displayed

In the main Dashboard window, you can turn off displaying service areas and stationary beacons by clicking **Service areas visible**, **Stationary beacons visible**.

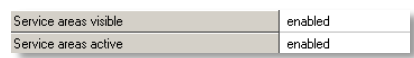

Statistics displayed depends on the chosen hedgehog in the list

Max smooth forward, smooth backward – depth smoothing

Smooth threshold - smoothing ratio.

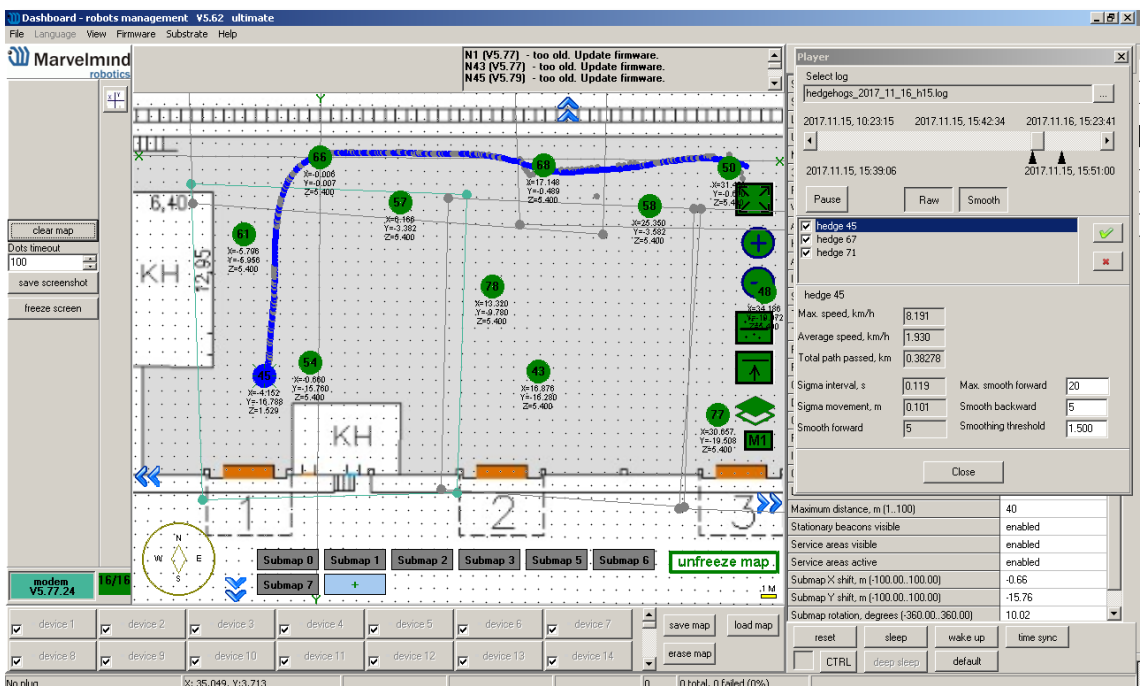
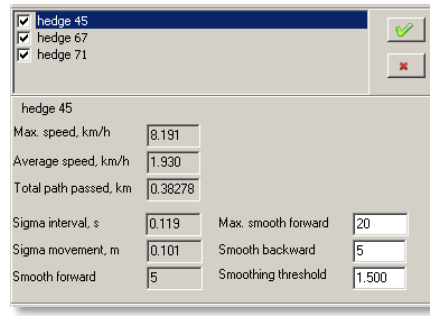

7.18 Real-time player feature (FN0010)

Real-time player is a feature, which makes the tracking path smoother. As far as it looks backward and forward it certain latency based on the selected parameters.

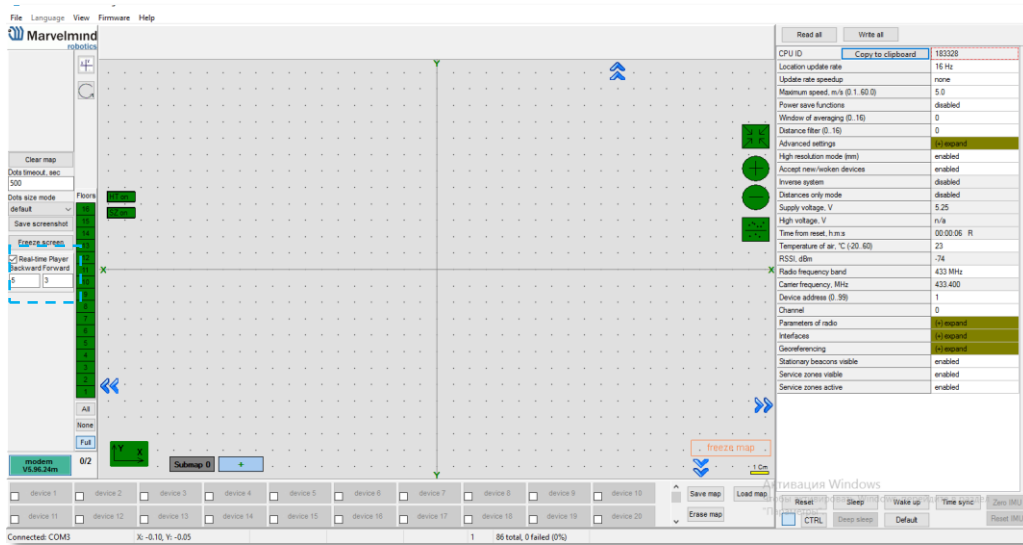

- Real-time player turned on by default

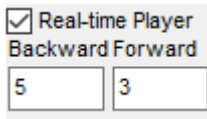

- You can turn it off if you need less delay

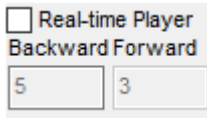

- You can tune it whether you need:

- **Backward** – amount of dots which player 'looks' backward to provide smooth tracking
- **Forward** – amount of dots which player 'looks' forward to provide smooth tracking

Tracking example:

Real-time player turned off



Real-time player turned on

The screenshot displays the Marvelmind Robotics software interface. At the top, there is a menu bar with 'File', 'Language', 'View', 'Firmware', and 'Help'. The main window is divided into several sections:

- Top Left:** A table showing data for four devices (25, 45, 55, 99). The table has columns for device ID and four numerical values.
- Center:** A 2D map with a grid. A blue path of dots starts from the bottom center and moves upwards and then rightwards. Several green circles represent robot positions. One robot is highlighted with a blue circle and labeled 'x112 377'. Other robots are labeled 'x112 382', 'x112 371', 'x112 380', 'x112 381', 'x112 379', 'x112 383', and 'x112 378'. A 'Submap 01' button is visible at the bottom of the map area.
- Left Sidebar:** Contains map control buttons: 'Clear map', 'Data timeout, sec' (set to 50), 'Data size mode' (set to 'default'), 'Save screenshot', 'Freeze screen', 'Real-time Player' (checked), 'Backward/Forward' (set to 5/3), 'All', 'None', 'Full', and 'modern VLS-Wire'.
- Top Right:** A table with 'Read all' and 'Write all' buttons. The table lists system parameters and their values.
- Right Sidebar:** A list of system parameters with checkboxes and values.
- Bottom:** A status bar showing 'Connected: COM3', 'X: 14.582, Y: -1.442', 'Rate: 6.0 Hz', and '708 total, 2 failed (0%)'. There are also buttons for 'Save map', 'Load map', and 'Erase map'.

Device ID	Value 1	Value 2	Value 3	Value 4
25	1.967	4.447	4.080	
45	1.967	3.864	4.951	
55	0.927	1.080	3.391	4.231
99	4.080	4.951	3.236	

Parameter	Value
CPU ID	183328
Location update rate	16 Hz
Update rate speedup	none
Maximum speed, m/s (0.1, 60.0)	5.0
Power save function	disabled
Window of averaging (0, 16)	0
Distance filter (0, 16)	0
Advanced settings	13 expand
High resolution mode (mm)	enabled
Accept new/wakeon devices	enabled
Inverse system	disabled
Distances only mode	disabled
Supply voltage, V	4.97
High voltage, V	n/a
Time from reset, h:m:s	00:07:06 R
Temperature of air, °C (20, 60)	23
RSSI, dbm	-25
Radio frequency band	433 MHz
Camera frequency, MHz	433.400
Device address (0, 99)	1
Channel	0
Parameters of radio	13 expand
Interface	13 expand
Scanfrequency	13 expand
Stationary beacons visible	enabled
Service zones visible	enabled
Service zones active	enabled

7.19 CSV format

Current Dashboard version supports additional timestamp. See the attached screenshot, the UNIX time in milliseconds is the first value.

In each line comma separated values, CSV:

- UNIX time in milliseconds (time since 1970.01.01)
- time from previous record in milliseconds
- time from running dashboard in milliseconds
- address of hedgehog
- X coordinate of hedgehog, meters
- Y coordinate of hedgehog, meters
- Z coordinate of hedgehog, meters
- address of stationary beacon
- raw distance from hedgehog to stationary beacon, meters

The last pair (beacon address, distance) is repeated n times equal stationary beacons quantity in the system.

```

1494780417562,16,12287484,10,5.643,-0.553,0.453,12,6.343,13,3.169,14,9.814,15,5.841,
1494780417609,47,12287531,10,5.643,-0.553,0.453,12,6.343,13,3.169,14,9.814,15,5.841,
1494780417625,16,12287547,10,5.643,-0.552,0.466,12,6.343,13,3.169,14,9.814,15,5.841,
1494780417687,62,12287609,10,5.643,-0.552,0.466,12,6.343,13,3.169,14,9.814,15,5.841,
1494780417703,16,12287625,10,5.643,-0.552,0.466,12,6.343,13,3.169,14,9.814,15,5.841,
1494780417703,0,12287625,10,5.643,-0.552,0.466,12,6.343,13,3.169,14,9.814,15,5.841,
1494780417750,47,12287672,10,5.646,-0.550,0.466,12,6.343,13,3.169,14,9.814,15,5.841,
1494780417812,62,12287734,10,5.646,-0.550,0.466,12,6.343,13,3.171,14,9.811,15,5.840,
1494780417812,0,12287734,10,5.646,-0.550,0.466,12,6.343,13,3.171,14,9.811,15,5.840,
1494780417843,31,12287765,10,5.646,-0.550,0.466,12,6.343,13,3.171,14,9.811,15,5.840,
1494780417843,0,12287765,10,5.646,-0.550,0.466,12,6.343,13,3.171,14,9.811,15,5.840,
1494780417875,32,12287797,10,5.642,-0.553,0.466,12,6.343,13,3.171,14,9.811,15,5.840,
1494780417875,0,12287797,10,5.642,-0.553,0.466,12,6.343,13,3.171,14,9.811,15,5.840,
1494780417937,62,12287859,10,5.642,-0.553,0.466,12,6.347,13,3.172,14,9.813,15,5.837,
1494780417968,31,12287890,10,5.642,-0.553,0.466,12,6.347,13,3.172,14,9.813,15,5.837,
1494780418031,63,12287953,10,5.649,-0.551,0.466,12,6.338,13,3.171,14,9.813,15,5.843,
1494780418078,47,12288000,10,5.649,-0.551,0.466,12,6.338,13,3.171,14,9.813,15,5.843,
1494780418140,62,12288062,10,5.642,-0.553,0.466,12,6.338,13,3.171,14,9.813,15,5.843,
1494780418140,0,12288062,10,5.642,-0.553,0.466,12,6.338,13,3.171,14,9.813,15,5.843,
1494780418171,31,12288093,10,5.642,-0.553,0.466,12,6.463,13,3.169,14,9.813,15,5.837,
1494780418203,32,12288125,10,5.642,-0.553,0.466,12,6.463,13,3.169,14,9.813,15,5.837,
1494780418265,62,12288187,10,5.648,-0.551,0.459,12,6.463,13,3.169,14,9.813,15,5.837,
1494780418312,47,12288234,10,5.648,-0.551,0.459,12,6.345,13,3.172,14,9.813,15,5.844,
1494780418375,63,12288297,10,5.651,-0.549,0.459,12,6.345,13,3.172,14,9.813,15,5.844,
1494780418375,0,12288297,10,5.651,-0.549,0.459,12,6.345,13,3.172,14,9.813,15,5.844,
1494780418390,15,12288312,10,5.651,-0.549,0.459,12,6.346,13,3.171,14,9.812,15,5.846,
1494780418421,31,12288343,10,5.651,-0.549,0.459,12,6.346,13,3.171,14,9.812,15,5.846,
1494780418468,47,12288390,10,5.651,-0.549,0.459,12,6.346,13,3.171,14,9.812,15,5.846,
1494780418468,0,12288390,10,5.651,-0.549,0.459,12,6.346,13,3.171,14,9.812,15,5.846,
1494780418546,78,12288468,10,5.651,-0.552,0.459,12,6.346,13,3.175,14,9.812,15,5.846,
1494780418546,0,12288468,10,5.651,-0.552,0.459,12,6.346,13,3.175,14,9.812,15,5.846,
1494780418593,47,12288515,10,5.651,-0.552,0.459,12,6.346,13,3.175,14,9.812,15,5.846,

```

Unix time (time since 1970.01.01 in milliseconds)	Time from running dashboard (milliseconds)	Hedgehog N10 X= 5.651 m Y= -0.552 m Z= 0.459 m	Raw distances to stationary beacons: N12: 6.346 m N13: 3.175 m N14: 9.812 m N15: 5.846 m
1494780418593	47		

8. Interfaces

Indoor “GPS” system supports many external interfaces that can feed measured location data to an external system (robot, copter, VR, etc.).

There are two different ways to obtain the mobile beacons’ location data from the system:

1. From the mobile beacons
 - Each mobile beacon knows its own position and does not know the positions of the other mobile beacons
2. From modem/router
 - Knows position of every mobile beacon in the system

Data from the mobile beacons and from the modem can be obtained at the same time, if necessary

A list of the supported interfaces is shown below.



More information on the interfaces can be found here:

[http://marvelmind.com/#Interfaces.](http://marvelmind.com/#Interfaces)

Supported interfaces

- **Mobile beacon:**
 - UART
 - SPI
 - Virtual UART via USB
 - NMEA
- **Modem:**
 - UART
 - SPI
 - Virtual UART via USB
- **Integrated with:**
 - Windows (PC & tablets)
 - Linux
 - Mac OS
 - Android (beacon)
 - ROS (beacon)
 - Raspberry (beacon)
 - Arduino (beacon)
 - PixHawk (beacon)
- **Sample code:**
 - C
 - Python

8.1 Super-beacon external interface pinout top view

Super-beacon external interface 4x4 pinout

- - External pins
- - Internal solderable contacts

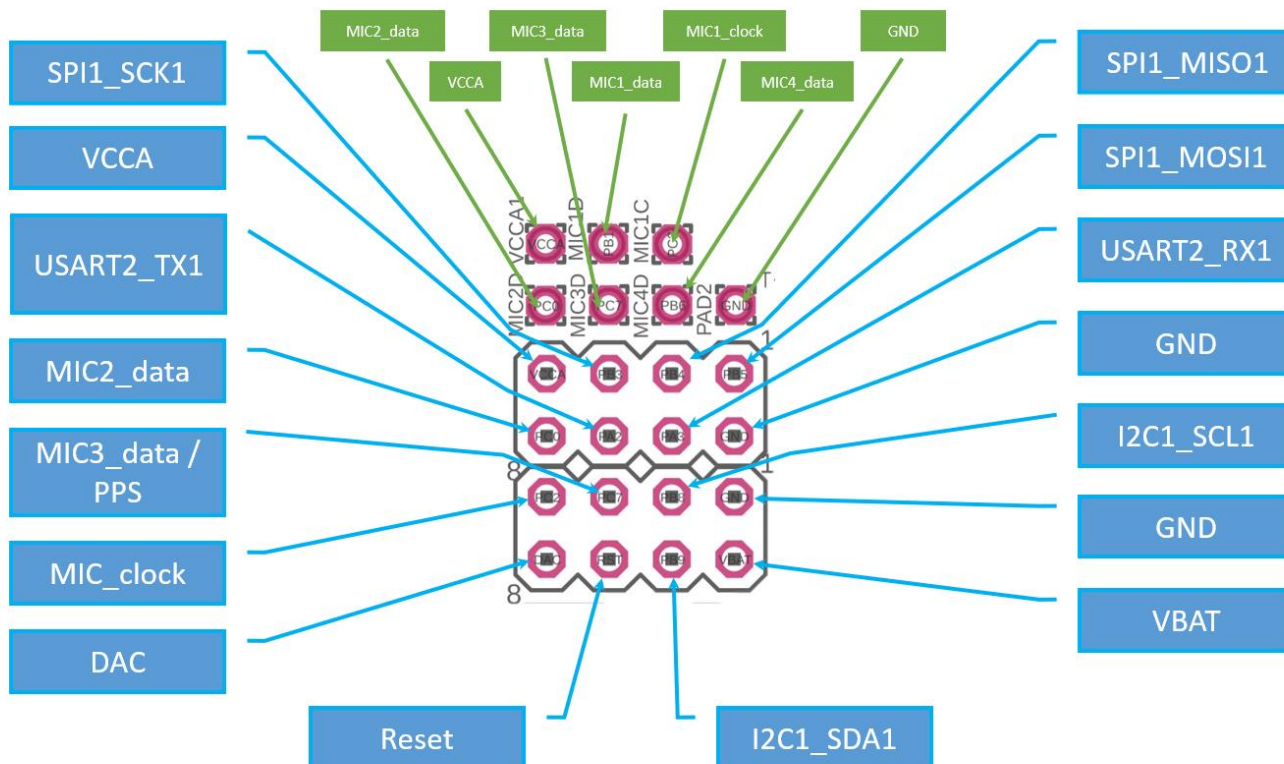

8.2 Beacon HW v4.9 external interface 4x4 pinout top view

Beacon HW v4.9 external interface 4x4 pinout

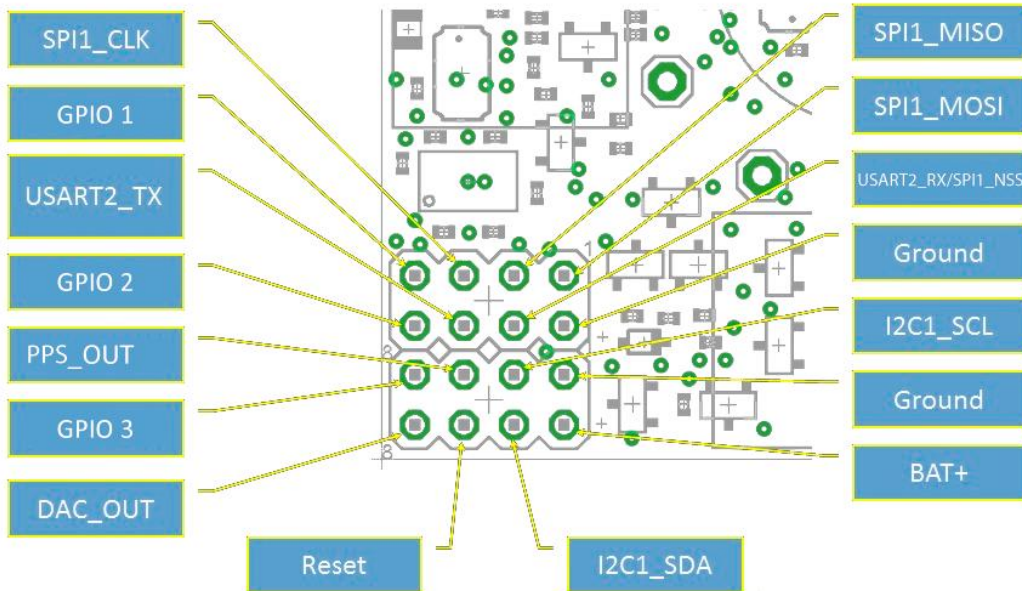

8.3 Modem HW v4.9 external interface pinout top view

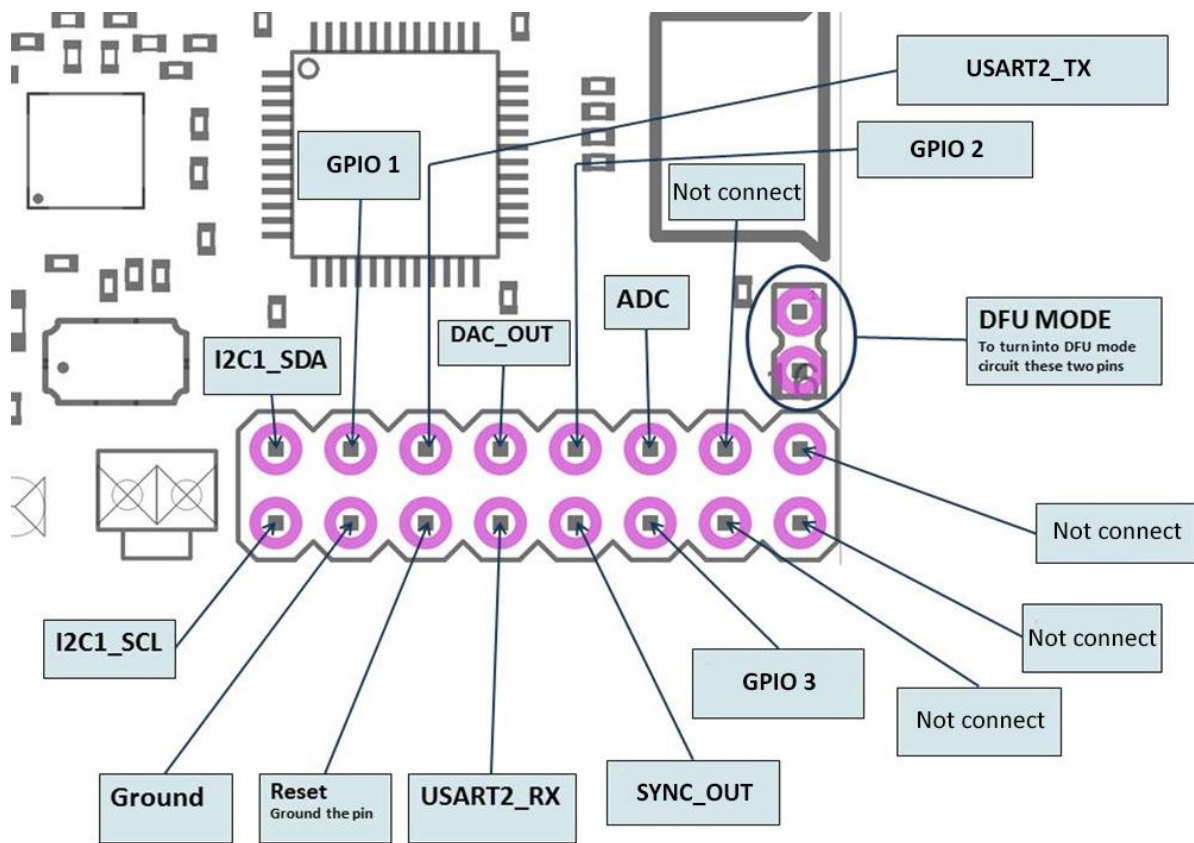



8.4 Mini-RX internal solderable pinouts (for experienced users only)



Use it only if you are sure that you can solder it correctly
Do not forget to turn off the beacon with DIP-switches
If you solder bad and kill the beacon, Marvelmind team won't be responsible for it

To get UART data streaming from beacon Mini-RX, you must solder to the pins on the board.

Mini-RX internal solderable pinouts

● - Internal solderable contacts

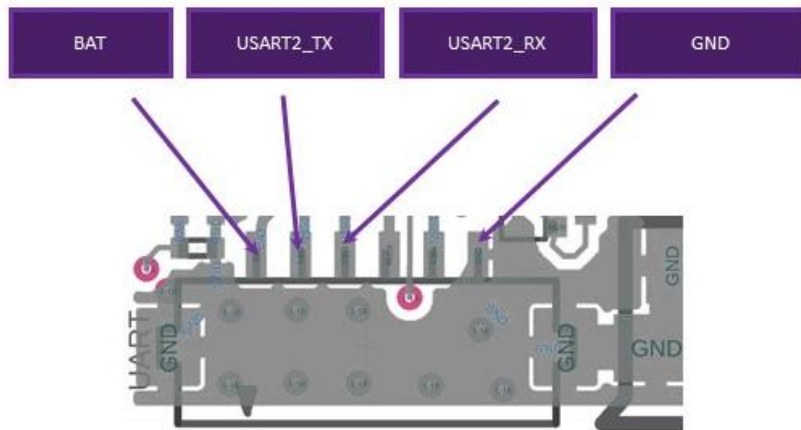

*BAT - you can disconnect internal battery and supply here an external power source of 3.5V-5.2V to the point with current up to 50mA



9. Advanced system settings and optimization

Start using advanced settings only when you are confident with the system.

If you run into trouble, connect the beacon or modem to the PC via USB and use the **DEFAULT** button. It will upload “factory settings” to the board while keeping the device address untracked.

Carrier frequency, MHz	433.400
Device address (0..99)	1
Channel	0
Parameters of radio	(+) expand
Interfaces	(+) expand
Georeferencing	(+) expand
Limitation distances	auto
Service areas visible	enabled
Service areas active	enabled
Submap X shift, m (-100.00..100.00)	0.00
Submap Y shift, m (-100.00..100.00)	0.00
Submap rotation, degrees (-360.00..360.00)	0.00

reset	sleep	wake up	time sync
<input type="checkbox"/> CTRL	deep sleep	default	



9.1 Building big maps in Inverse Architecture (IA)

! This chapter is applicable only for Inverse Architecture

9.1.1. Introduction

In this chapter we described building big maps in **IA**. It has differences from classic NIA map building because we have more than 1 ultrasonic frequency, and we need to make sure that they do not interfere with each other. Please, read carefully.

A **map** is a system unit that includes **submaps**, **stationary beacons** and **service zones** within which positioning of **mobile beacons** is ensured by ultrasonic signals from the stationary beacons of this submap.

Handover zone (marked blue)

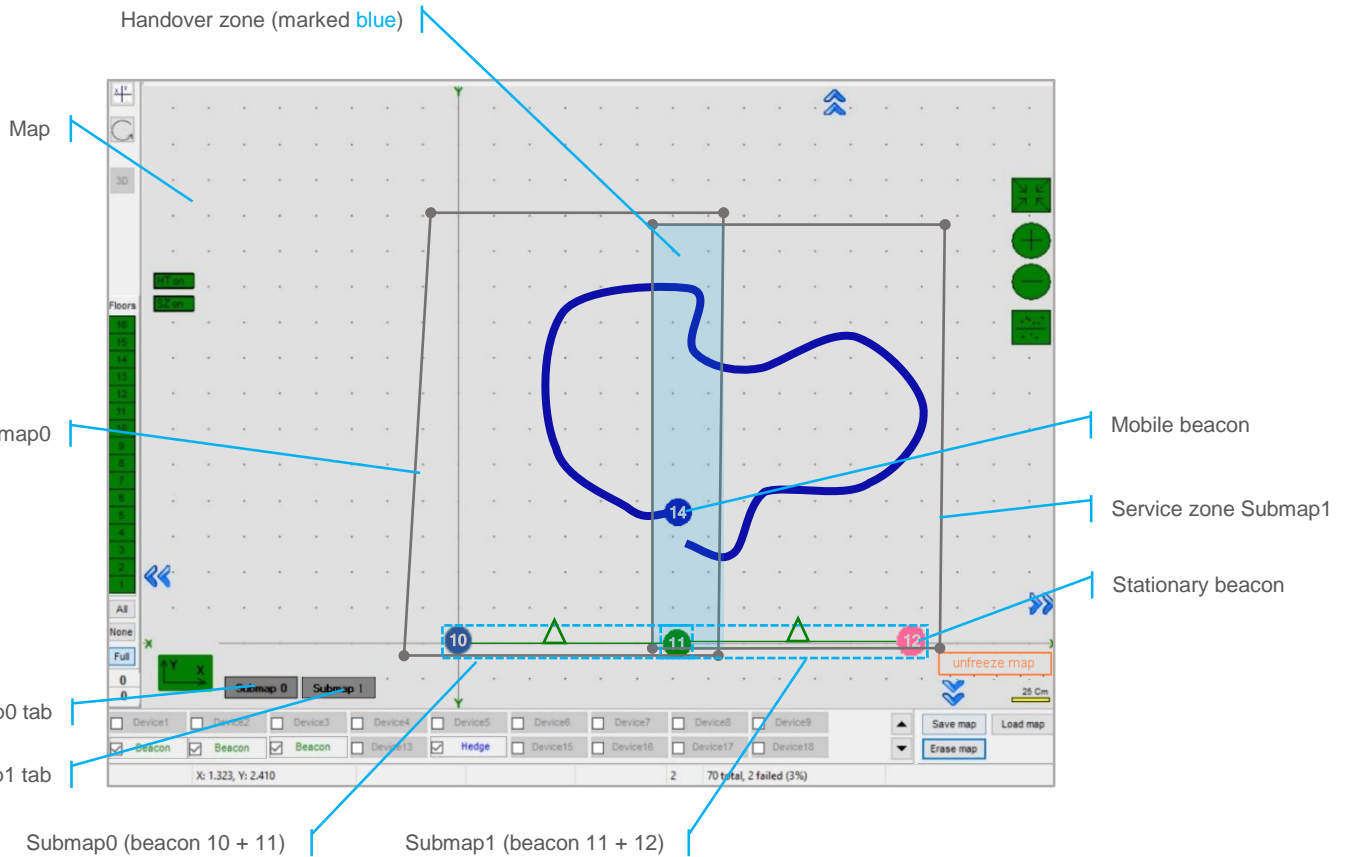

The main parameters of a submap are its **size**, **frequencies**, **jitter codes** and **TDMA position** of stationary beacons, by which mobile beacons can not only be positioned, but also determine in which submap the mobile beacon is located.

9.1.2. Map

Map – the biggest unit in Marvelmind Indoor GPS. It consists of submaps and form full map of all stationary devices you have. After you build and tune all the submaps, waked up mobile beacon, you have to click on Modem icon and Freeze the map. It is the final stage of building the system. After you freeze map, tracking will appear.

You can **Save, Load, Erase** map:

Map Settings offer some helpful tools, it is situated in the right bottom corner of the Dashboard:

- Save map – saves map as *.ini* file into **Dashboard folder/maps**
- Load map – loads map from *.ini* format file
- Erase map – erases map and clears it

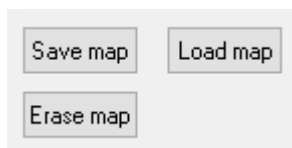

9.1.3. Submaps

Submap is a logical unit. A part of the map. It unites beacons to work together in the system. Submap can contain from 1 to 4 beacons. It can be 1D, 2D, and 3D.

Different types of submaps can be used together. Mix 1D, 2D, 3D as you wish. Map of the office floor, for example, may contain 1D submap for corridor, 2D/3D submaps for office rooms. All that submaps will form a big map with coverage you need.

Submaps can contain the same beacons. It makes possible to use 3 beacons instead 4. It is very helpful in the IA because we are limited with 5 ultrasonic frequencies.

Example 1. Used 3 beacons for 2 2D submaps. Beacon 11 – neighboring. It belongs to Submap 0 and Submap 1 at the same time. 2 vacant frequencies left:

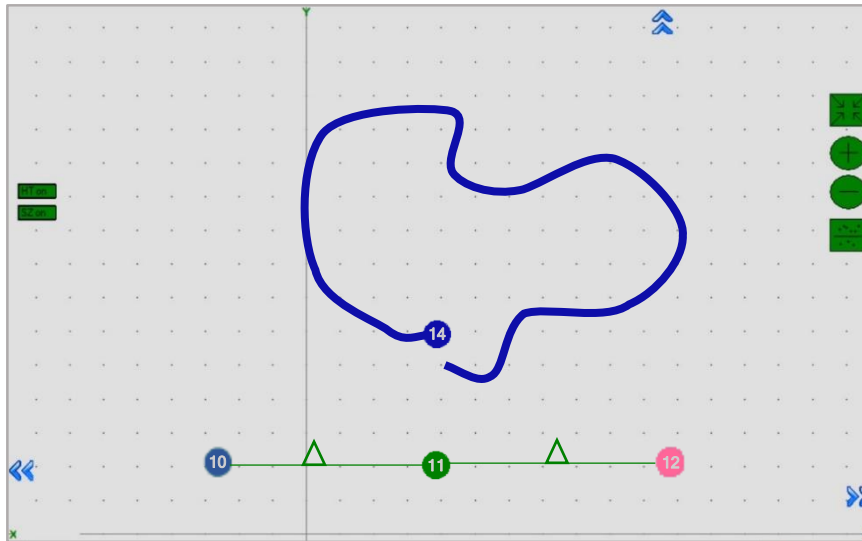

Example 2. Used 4 beacons for 2 2D submaps. Submap 0 and Submap 1 are independent. 1 vacant frequency left:

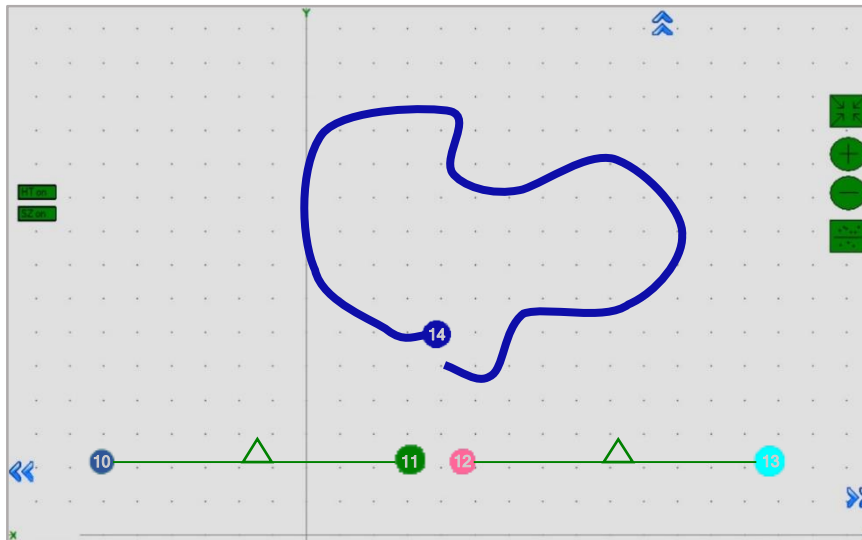

Different configurations suit different cases. You can also have submaps with neighboring beacons and submaps without it on the one map.

9.1.4. Submaps' service zones

Service zone (or service area) is an area which serve submap. Service zone must be drawn for any submap you build. It helps to divide tracking between different submaps and outline the area of responsibility of every submap.

How to create a service zone:

- **Choose submap (click on the submap icon)**
- Use **SHIFT + Left mouse button** on the map to create point.

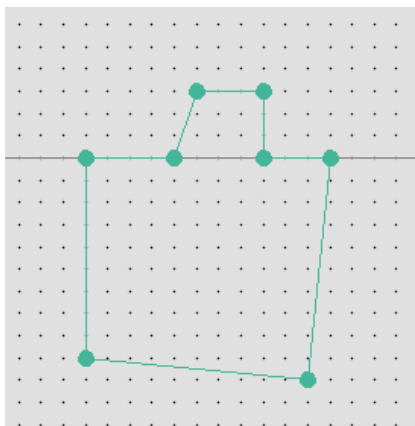

- Use **SHIFT + Left mouse button** on the point to delete it.

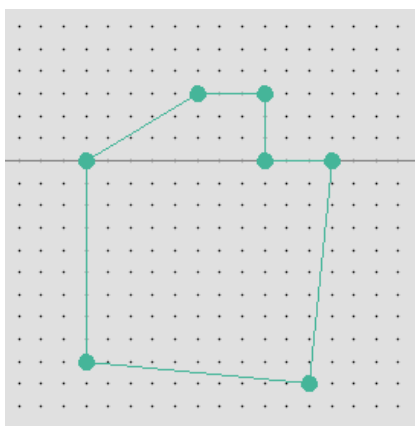

- Put points around submap, move them to provide service area for current submap. Service areas will cross each other. If hedgehogs get lost between two submaps expand the service area

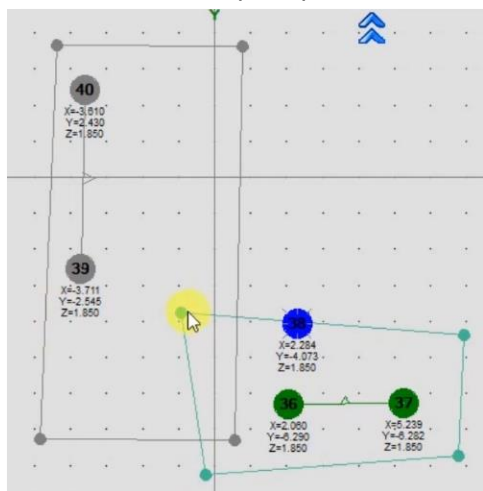

9.1.5. Handover zones

Handover zone is an area which creates when service zones cross. It serves to make a smooth transfer of mobile beacon from service zone of one submap to another

Handover zone (marked blue)

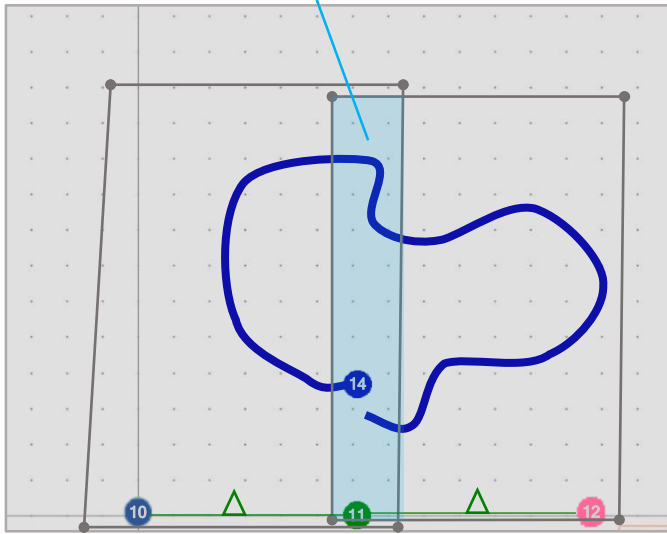

How to create Handover zone correctly

Size of a Handover zone may be different and depends on the mobile beacon's speed and system's update rate. We recommend testing it with the speed of your mobile beacon mounted on a person/robot/copter. General recommendation is – to make handover smooth and correct, make sure that your mobile beacon makes at least 4 refreshes in a handover zone.

Look at the following examples:

Example 1: Normal handover zone:

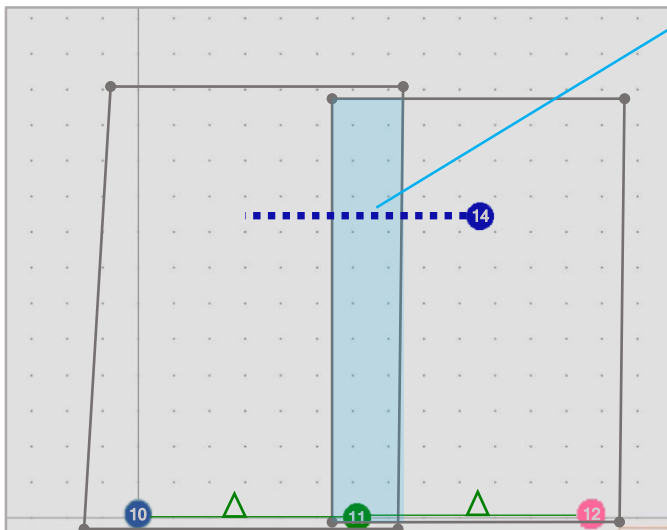

Hedge made 4-5 updates - CORRECT

Example 2: Small handover zone:

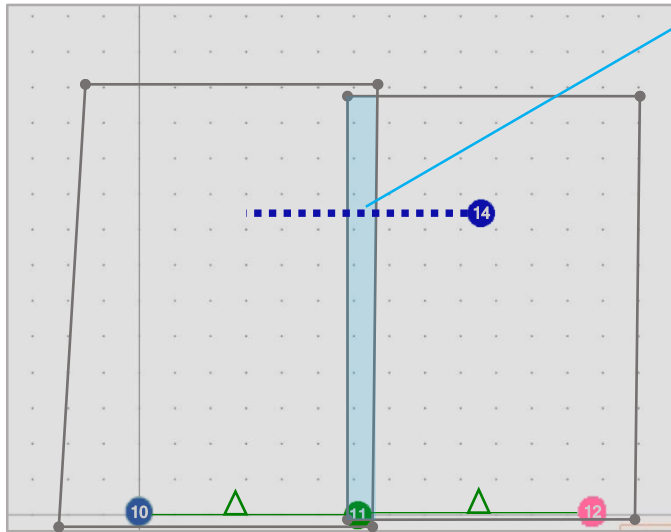

Hedge made 2-3 updates – **MAY BE NOT ENOUGH**

Example 3: Very small handover zone:

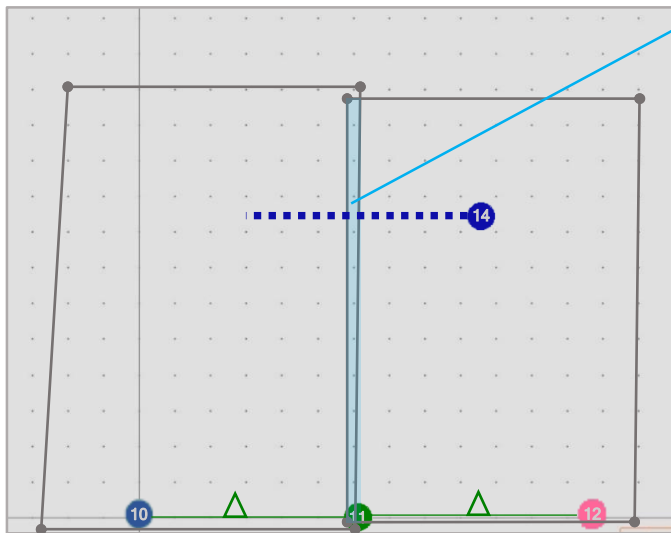

Hedge made 1-2 updates – **NOT ENOUGH**

Example 4: No handover zone:

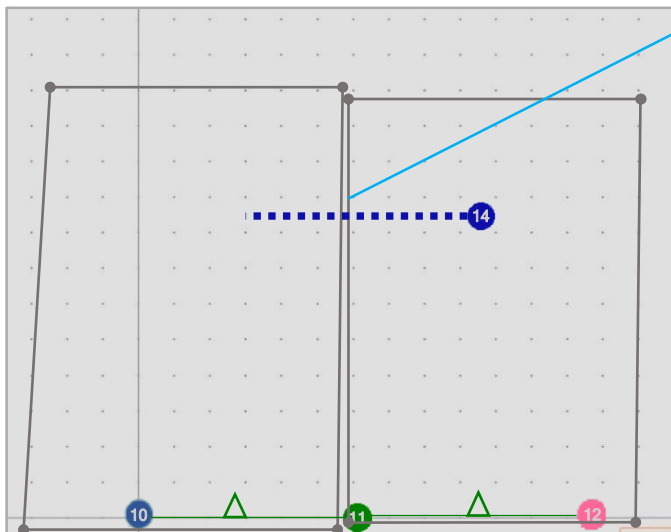

Service zones not cross – **NO HANDOVER ZONE CREATED, NO HANDOVER BETWEEN SUBMAPS**

9.1.6. Beacons' ultrasonic frequencies

Beacons must have different ultrasonic frequencies in IA. It can be used for different aims and different cases.



Please notice that is hardware defined and cannot be just changed via settings in the Dashboard

Different frequencies can be used:

- In IA as a basic rule of Inverse Architecture's functionality
- In NIA (Multi-frequency NIA) to increase update rate for multiple mobile beacons

To make it easy to distinguish, stationary beacons with different frequencies in the Dashboard colored in different colors:

-  - 19KHz beacon
-  - 25KHz beacon
-  - 31KHz beacon
-  - 37KHz beacon
-  - 45KHz beacon

9.1.7. Beacons' jitter codes

In order for the beacon to be able to move between submaps, the **service zones** of these submaps **must intersect**, the intersection area of the service zones of neighboring submaps forms a **handover zone**, when the beacon enters the handover, it becomes possible for it to go to the neighboring submap. This ensures the positioning of the beacon on the entire area of the map.

Jitter is a code corresponding to a stationary beacon, depending on the code, a stationary beacon introduces a delay before emission and, accordingly, the received signal will be delayed by this value, the mobile beacon knows this delay by the emission cycle number and makes the appropriate distance adjustment.

Jitter codes, sets of ultrasonic frequencies and **TDMA** makes every submap unique and let mobile beacon displays in correct submap.

9.1.8. Examples of map building and beacons' placement

To make it possible for beacon to switch from the current submap to the neighboring one, the uniqueness condition for the frequencies of neighboring submaps is required, i.e. for any submap, **all adjacent submaps must not have repeating sets of frequencies + jitter codes + TDMA sequence, it should be unique set for every submap.**

How to decipher the notation below:

$$19\text{kHz}(j_0, T_1) = 19\text{kHz beacon, jitter}=0, \text{TDMA } 1$$

Sets of frequencies:

Example 1:

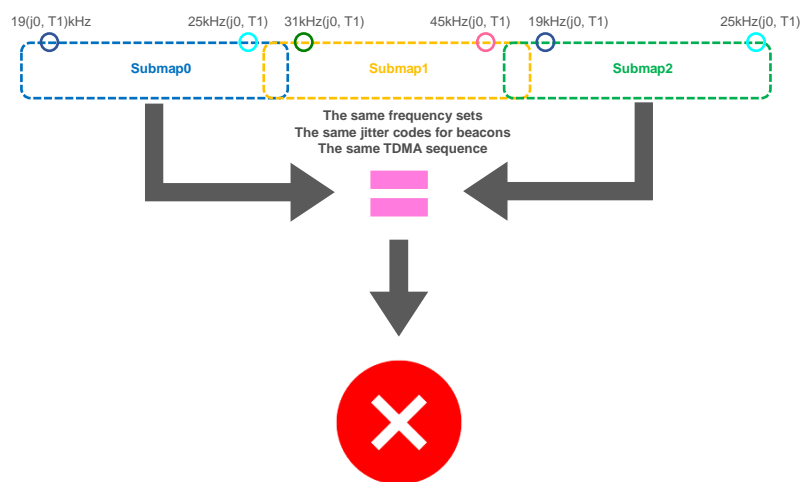

Submaps the same - INCORRECT

In this example, **submap1** has two adjacent submaps with the same frequencies (19-25kHz) – It is **INCORRECT**.

Example 2:

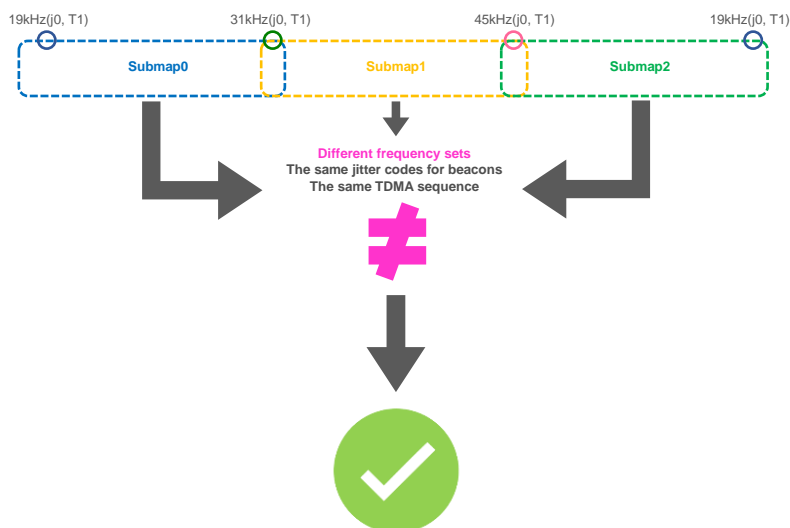

Submaps differ - CORRECT

In this example, sets of frequencies are: 19-31kHz, 31-45kHz and 45-19kHz, while there are no repetitions in adjacent submaps, while further construction of submaps using the same frequencies is allowed, i.e. 19-31kHz, 31-45kHz, 45-19kHz, 19-31kHz, 31-45kHz, 45-19kHz, because in this case, repetition does not occur – It is **CORRECT**.

Jitter codes:

To make it possible for beacon to determine which submap it is located, it is necessary to fulfill the uniqueness condition for the set of frequencies and jitter in the submap with respect to the entire map. It allows to use the same sets of frequencies.

For instance:

Example 1:

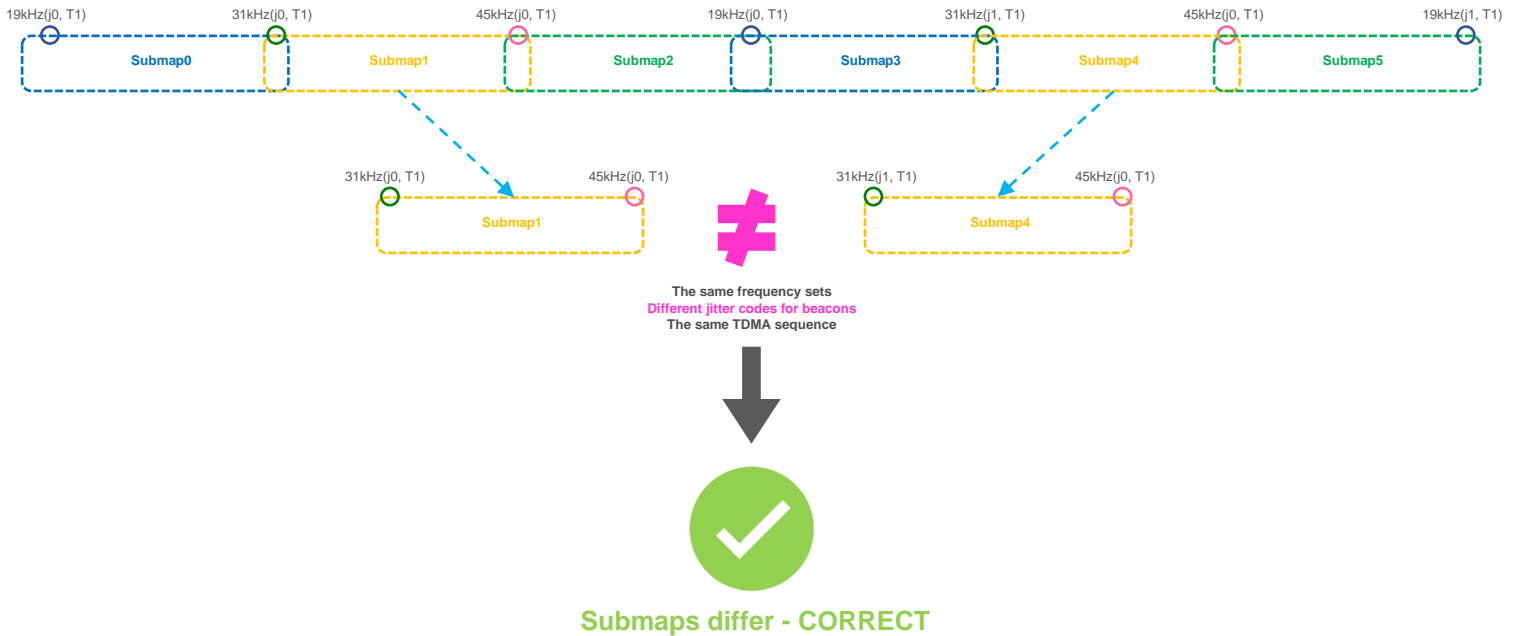

In this example, frequency sets are: 19kHz(j0, T1)-31kHz(j0, T1), 31kHz(j0, T1)-45kHz(j0, T1), 45kHz(j0, T1)-19kHz(j0, T1), 19kHz(j0, T1)-31kHz(j1, T1), 31kHz(j1, T1)-45kHz(j0, T1), 45kHz(j0, T1)-19kHz(j1, T1), while there are no repetitions within the entire map – It is **CORRECT** map building

The following particular qualities must apply to handovers, within one submaps, the handover zones of other submaps cannot overlap, switching to a neighboring submap is possible only from a handover between these submaps.

TDMA sequence:

As far as we have only 5 ultrasonic frequencies, when we build big maps and when ultrasonic signals may interrupt each other, we must use TDMA. In this case submaps that cannot be used together will work alternately. Please notice that update rate falls by a multiple of TDMA sequence. If you have 8Hz basic update rate without using TDMA, 3 TDMA sequences will make it 8/3Hz.

TDMA is the mode of sequential radiation, when for each stationary beacon the number of the cycle in which it should emit and the number of cycles of radiation after which these numbers are repeated is set

We have 3 TDMA types:

- **Type 1** - TDMA as NIA multiple beacons' working algorithm
- [Type 2 - Full-overlapping TDMA \(For better coverage in 2D\). See more on TDMA chapter](#)
- **Type 3** - TDMA for huge IA maps building (described below)

For building huge maps in IA, we need **TDMA Type 3**.

Example 1:

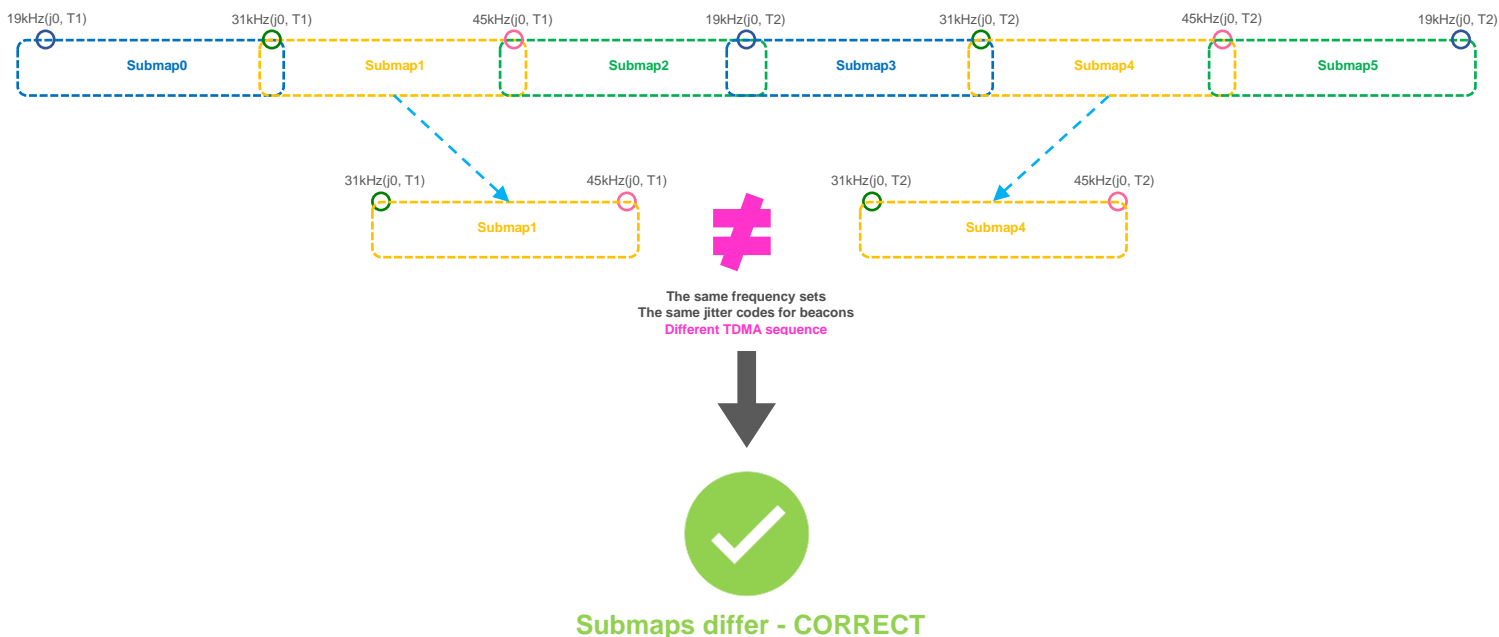

Example 2:

For example, a **100x100 meter map in open-spaced area** consists of 55 submaps, the vertical rows of submaps are the same, but operate in different TDMA loops using **TDMA type 3**. In this example we used different colors for every TDMA position in sequence. TDMA 1(red) submaps emit first, TDMA 2(green) submaps emit second, TDMA 3(blue) submaps emit third:



Moreover, the map consists of $6 \times 11 = 66$ stationary beacons, i.e. 11 beacons of each of the frequencies combined into submaps: 19-31kHz, 31-45kHz, 45-19kHz, 19-37kHz, 37-25kHz.

9.1.9. Map building

Before building a map, you need to determine the need to use jitter and if it is necessary to select a mode, the modes differ in information capacity and transmission speed, i.e. for how many cycles the jitter code is transmitted:

- **Jitter Mode1** - information capacity = 6 bits, and transmitted in 2 cycles.
- **Jitter Mode2** - 8 bits, 4 cycles.
- **Jitter Mode3** - 4 bits, 8 cycles.

The beacon movement introduces distortions in the definition of jitter code, therefore for objects moving fast, the most suitable mode is 1. So using 5 frequencies you can build 10 unique sub-maps in a set of frequencies, without using jitter, if this number is insufficient or not in the presence of a complete set of frequencies or you cannot use them because of the requirement of uniqueness of neighboring sub-maps, use jitter.

For example, when using **Jitter Mode1** and only two codes 0 and 1 for each stationary beacon, from 10 initial combinations, you can get 40 submaps, because each submap contains two beacons and, accordingly, 4 combinations, however this number may turn out to be slightly less when one stationary beacon enters into more than one submap, because the number of combinations is reduced. You can select a mode in the Dashboard menu.

You also need to select **Jitter granularity**, each ms is 0.343m i.e. 3ms corresponds to 1.03m, which is enough for most cases.

You also need to select the **Jitter area**, this parameter indicates the neighborhood around the jitter value, which is considered a valid deviation of the jitter value, if this deviation is exceeded, the accepted jitter value is considered incorrect and does not take part in determining the submap.

Read all		Write all	
CPU ID	Copy to clipboard	0F2336	
Firmware version	Modem HW v4.9		
Location update rate	8 Hz		
Update rate speedup	none		
Maximum speed, m/s (0.1..60.0)	5.0		
Jitter mode	mode 1		
Jitter granularity, ms (1..16)	3		
Jitter area, % (0..50)	35		
TDMA mode	disabled		
Long time sleep	disabled		

Select and set the **Code of jitter** in the menu of the emitting beacon

Number of periods (1..100)	10
Code for jitter TX (0..63)	1
TDMA mode	TDMA mode 1

Next, you need to choose submap 0, add the beacons included in submap 0, and set the jitter code for them.

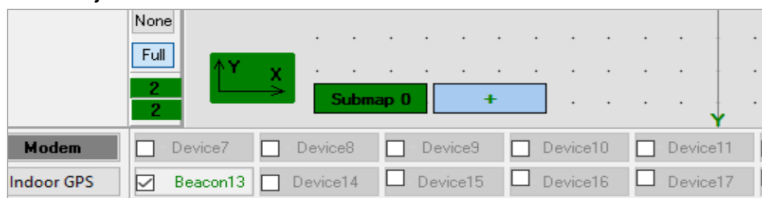

If the distance is determined correctly in the automatic measurement mode, you can leave it in the distance table unchanged.

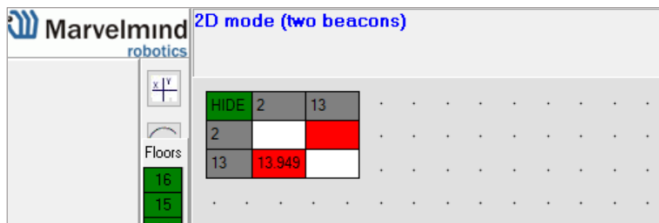

If you need to change it, you can do this through the context menu. See detailed description of manual map building in the [Operating Manual – Table of Distances](#) chapter

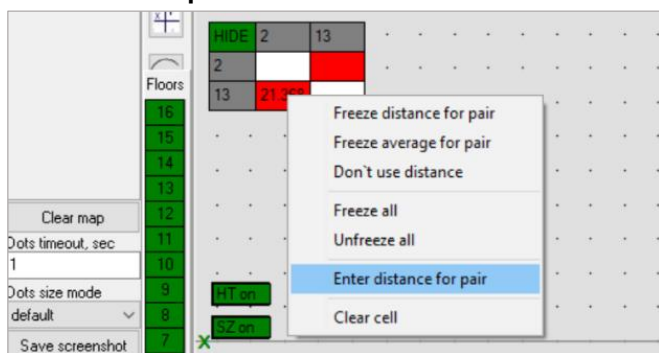

And set the required distance manually.

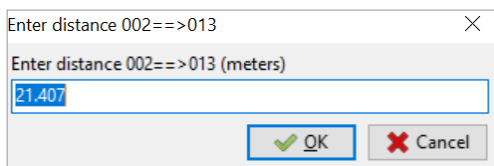

Then you need to move the submap to the desired coordinates, using the settings of the submap (click on the submap's tab icon and settings tab will appear in the right side of the Dashboard), to specify its displacement and rotation

Submap X shift, m (-320.00..320.00)	0.00
Submap Y shift, m (-320.00..320.00)	0.00
Submap Z shift, m (-320.00..320.00)	0.00
Submap rotation, degrees (-360.00..360.00)	0.00
Plane rotation X, degrees (-360.00..360.00)	0.00
Plane rotation Y, degrees (-360.00..360.00)	0.00
Plane rotation Z, degrees (-360.00..360.00)	0.00
Service zone thickness, m (-320.00..320.00)	0.00
Hedges height in 2D mode, m (-320.00..320.00)	0.00

After that, you need to freeze the selected submap, create the next one by pressing the “+” button, make it active and repeat the operations starting from adding beacons to the new submap.



When all the submaps are installed and frozen, you need to turn on all mobile beacons, add them to the card and freeze the map.



After freezing, the parameters of stationary beacons and submaps are transferred to the beacons and stored in flash. Further, to change the parameters of the map, you will need to unfreeze it and freeze it again in order to repeat the transfer of parameters to the beacons.

9.1.10. Testing

The ability of a beacon to correctly position itself and determine the submap in which it is located completely depends on the correct measurement of the distance to each stationary beacon

Stationary beacons in a submap emit at different frequencies. It is important to ensure the same reception conditions from different stationary beacons and frequencies, respectively, because the emission spectrum at one frequency has limited suppression at a neighboring frequency.

The signals can flow into adjacent frequency channels, this is reflected in the appearance of false triggers and incorrect determination of the distance, as a result of incorrect positioning, incorrect jitter detection and, accordingly, incorrect determination of the submap.

To find the causes of such problems, the dashboard has a digital oscilloscope mode, it displays the envelope of the received signal and trigger triggers. It is necessary to verify that the main candidate corresponds to the actual distance and that there are no other candidates that could interfere with the correct measurement.

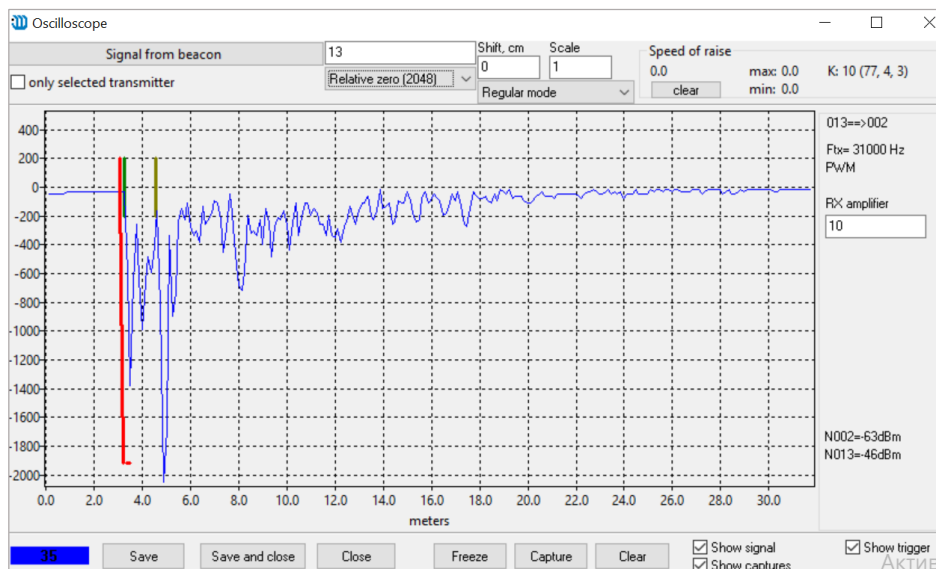

As a rule, false candidates preceding the correct one are a consequence of the penetration of a different frequency, you can check this by turning on the “only selected transmitter” option, and only the selected beacon on one frequency will emit, if the false candidate disappears, then this is penetration of a different frequency and you need to check whether the restrictions are met described above.

Another case is re-reflection, when the signal reflected from neighboring objects and turns out to be higher than the main candidate. As a rule, in this case the false candidate is further than the main candidate, but it cannot be much further due to attenuation. In this case, you can use the “**Min. over raise for new front**” beacon’s setting.

Min. over raise for new front (0..200)	30
--	----

This parameter prefers the candidate who is closer.

When positioning is done correctly, you need to make sure that the given jitter is correctly estimated, the stationary beacon emits a signal without delay and with a delay equal to the jitter code multiplied by granularity, in an oscilloscope this looks like a shift of the main candidate by jitter.

Map built, tested and ready to use.

9.2 TDMA Type 2 - Full-overlapping TDMA

The steps below describe how to run IA with TDMA feature, which helps to improve the tracking quality in complex situations.

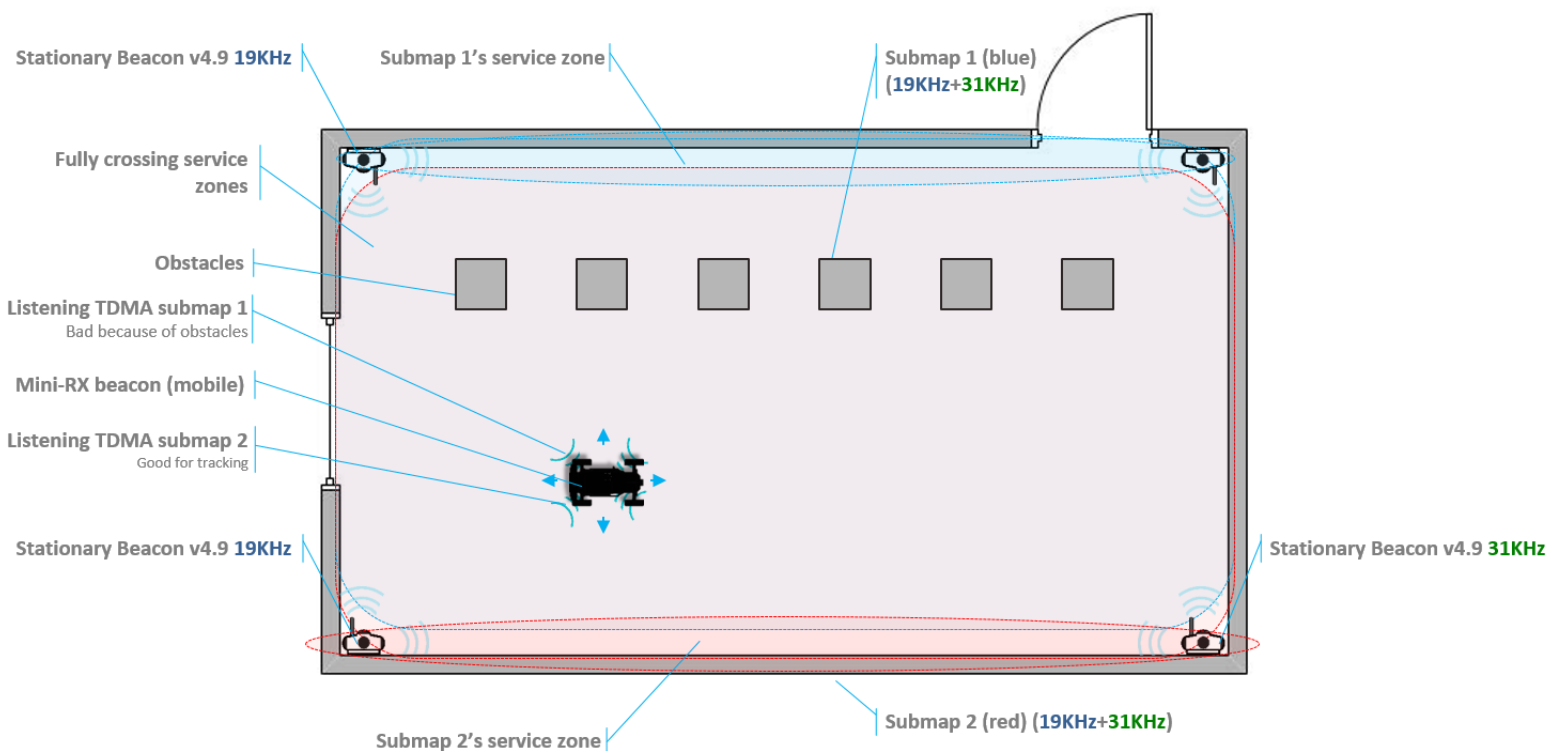

Suitable for IA only. Use IA Software

Beacons HW v4.9 should have different frequencies

When you work with two TDMA submaps, update rate reduces twice.



10.1.1. Mount stationary beacons in according to the TDMA chapters in [Placement manual](#).



10.1.2. Wake up beacons included in Submap0. Enter the values in the table “distance between beacons”, Freeze it. If necessary, set the shift, rotation, height, etc. **Draw a service zone** (More info: [Submaps feature](#) description).

10.1.3. Wake up beacons included in Submap1. If the submap uses beacons from other submaps, you must add them to the current one. **Draw a service zone, fully crossing with Submap0's service zone.**

10.1.4. If submaps with the same set of frequencies intersect, it is necessary to use TDMA. *(This is the mode of sequential radiation, when for each stationary beacon the number of the cycle in which it should emit and the number of cycles of radiation after which these numbers are repeated is set)*

For example, in the room there are beacons 19kHz, 45kHz and two 31kHz and submaps respectively 19kHz+31kHz and 31kHz+45kHz both include beacon 31kHz, therefore for all beacons the length of the TDMA sequence is set to 2, while the position in the TDMA sequence for beacons in 19kHz+31kHz submap is set to 0, and for beacons in 31kHz+45kHz submap is set to 1. As a result, the radiation of beacons in submaps occurs sequentially, first 19kHz+31kHz submap, then 31kHz+45kHz submap. You can also use absolutely the same set of frequencies in submaps (Submap0 = 19kHz+31kHz, Submap1 =

19KHz+31KHz)

Duty, % (1..99)	50
Number of periods (1..100)	24
TDMA sequence length (1..8)	1
TDMA position in sequence (0..7)	0
Amplifier limitation (calibrated)	4000
Amplification	AGC

10.1.5. Activate mobile beacons.

10.1.6. Freeze the entire map. Now, you can work with it.

10.1.7. If you have any jumps, that can mean that you have wrong submaps' positions. Unfreeze all and try to move it until you get their correct positions.

TDMA modes:

System supports two modes of TDMA:

- **Mode 1 (Adaptive):** Hedge determines which submap sees it better at the moment, and tracks in it. It can give better tracking, but in bad conditions, it may cause mistracking
- **Mode 2 (Classic):** Hedge tracks in two submaps one by one. It can give solid 50/50 tracking in conditions where one submap can't see the hedge at all. After measurements, Real-Time Player makes tracking smooth, filtering out mistracking

Each mode has its pros and cons. Try them both and choose the best suiting for your case.

How to change modes:

- Choose hedge
- Go to **Ultrasound -> TDMA mode**
- **Left mouse button click** to change

Ultrasound	(-) collapse
Mode of work	Normal
Analog power in sleep	enabled
Power after transmission	turn off
Transmitter mode	PWM
Frequency, Hz (100..65000)	31000
Duty, % (1..99)	55
Number of periods (1..100)	33
TDMA mode	TDMA mode 1
Amplification	manual
Receiver amplifier (0..4095)	200
Time gain control	disabled
Mode of threshold	automatic

9.3 Increasing update rate

The update frequency is affected by 2 main parameters:

- 1) Radio profiles
- 2) Room dimensions (tracking areas)

If you need to tune the update rate of tracking, do the following:

- 1) Radio profiles:

There are 3 radio profiles available: 38kbps, 153kbps, 500kbps:

- **38kbps** is the slowest, but is able to cover a greater distance
- **153kbps** - average speed, overcomes the average distance (**default**)
- **500kbps** is the fastest, but works at a shorter distance

Accordingly, to **raise the update rate**, we recommend **switching to 500kbps**.

How to:

In the settings bar of each device in the system (including modem), change the Radio profile parameter to **500kbps** (or any you need). It is situated in the Dashboard, on the right side of the Dashboard screen.

Tip: Change the beacons' profile before modem's, in order not to lose your beacons. It allows you to do it remotely

- 2) Room dimensions (tracking areas)

Update rate is also having linear dependence with tracking distance (distance between stationary and mobile beacon):

- Longer** distance – **lower** update rate
- Smaller** distance – **higher** update rate

If you have room 10x10m, change maximum distance setting. This will limit the system to the maximum measurement distance.

How to:

- Go to the submap settings (click on the submap icon)
- Change maximum distance value in meters (20 is a default)

Tip: Do not enter very small value, use 1-2 meter's margin. Also, do not use 20 meters if you have small tracking area. Tune carefully

9.4 Reducing location update latency

Exact latency depends on many factors:

- IA or NIA
- From modem or from the beacon
- IMU sensor fusion or regular ultrasonic only
- Radio profile
- Realized update rate
- Any sort averaging or Real-time player enabled or not

The range is:

- ~ 12ms for data from a mobile beacon via USB with IMU fusion enabled and not averaging at all
- ~ 150ms with 30m-submap and update rate in ultrasonic of 7Hz and not averaging
- ~ 2 seconds with the same settings as in (b), but Real-Time Player with settings 16, i.e. it takes into account up to 16 previous readings before giving out the new one

9.4.1. What affects delay:

9.4.1.1. [Real Time Player](#) in the Dashboard (For **NIA**)

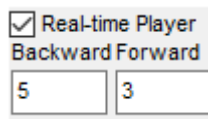

<input checked="" type="checkbox"/> Real-time Player
Backward Forward
5 3

9.4.1.2. [Real Time Player in hedge](#) (For **IA**)

Real-time player	disabled
Real-time player backward (0..127)	3
Real-time player forward (0..127)	5

9.4.1.3. [Window of averaging and Distance filter settings in modem](#) (For **NIA**)

Window of averaging (0..16)	4
Distance filter (0..16)	3

9.4.1.4. [Prefiltration coefficient and Ultrasonic filtering settings in hedge](#) (For **IA**)

Prefiltration coefficient (0..127)	0
Ultrasonic filtering (0..255)	40

9.4.2. How to decrease latency:

9.4.2.1. Turn off the [Real-Time Player](#) (works for **IA** and **NIA**)

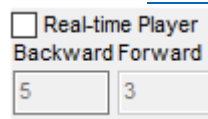

<input type="checkbox"/> Real-time Player
Backward Forward
5 3

9.4.2.2. Change the [Window of averaging and Distance filter](#) settings value to 0 (For **NIA**):

- Choose **Modem** -> **Window of averaging** (in the right tab) -> **Enter 0 value**
- Choose **Modem** -> **Distance filter** (in the right tab) -> **Enter 0 value**

9.4.2.3. Change the *Prefiltration coefficient* and *Ultrasonic filtering* settings value to 0 (**For IA**):

- Choose your mobile beacon. Go to **Ultrasound** -> **Prefiltration coefficient** -> **Enter 0 value**
- Choose your mobile beacon. Go to **Ultrasound** -> **Ultrasonic filtering** -> **Enter 0 value**

9.4.2.4. Complete. Latency reduced

9.5 How to Place Beacons

Avoid placing beacons on long sound-conducting objects

This is very rare but may happen under some special circumstances.

The best practice is to place beacons (stationary and mobile) in places that would not result in the transfer of ultrasound energy from the beacon's board/case directly to the place it is attached via a medium other than air. For example, solid attachment of a beacon to a long horizontal metal tube may result in the following:

- Sound emitted from the beacon propagates directly to the metal tube.
- Propagation losses inside metal are much smaller than in the air. Moreover, the tube may act as a low-loss waveguide.
- If the tube is solid enough and long enough, there may be an unusual effect where the receiving beacon receives the signal sooner than expected, i.e., sooner than the distance divided by the speed of sound in air. That happens because the speed of sound in metal is much higher than the speed of sound in the air. The ultrasound signal may even look stronger than the real signal propagated through the air due to the lower amount of losses of ultrasonic in metal than in the air.
- It is good practice to place beacons on something relatively soft or something that does not conduct sound.

Place beacons in a way that provides the proper ultrasonic coverage. It must be one beacon in the line of sight of minimum 2 beacons. Try to locate them under ceilings to avoid shadows, walls etc.

- Optimal settings for stationary beacons in small and big rooms.
- Use 30–50 ultrasonic pulses for larger places and the default 5 pulses for smaller places.
- Optimal settings for noisy environment.

There are several ways to reduce impact:

- Mobile beacons can be placed very close to the source of noise without harm, but stationary beacons should be placed further from the noise because they are receiving the ultrasound, whereas the mobile beacon is emitting the ultrasound.

9.6 Using the Oscilloscope

- Monitor the ultrasonic signal from one beacon to another
- Use **Dashboard => View => Oscilloscope** to monitor ultrasonic signals from one beacon to another
- It is a very powerful tool, because it also gives information on the background noise, level of the signal, echo, etc. With this tool, it is easy to set up the proper ultrasonic threshold on the Dashboard.

Echo

External noises look similarly. Thus, choose the ultrasonic threshold below this value, for example, -500 to -2000

Type the reference beacon number and press Enter

Ultrasonic signal front

Trigger (red line)

Emission counter

Choose the beacon to test

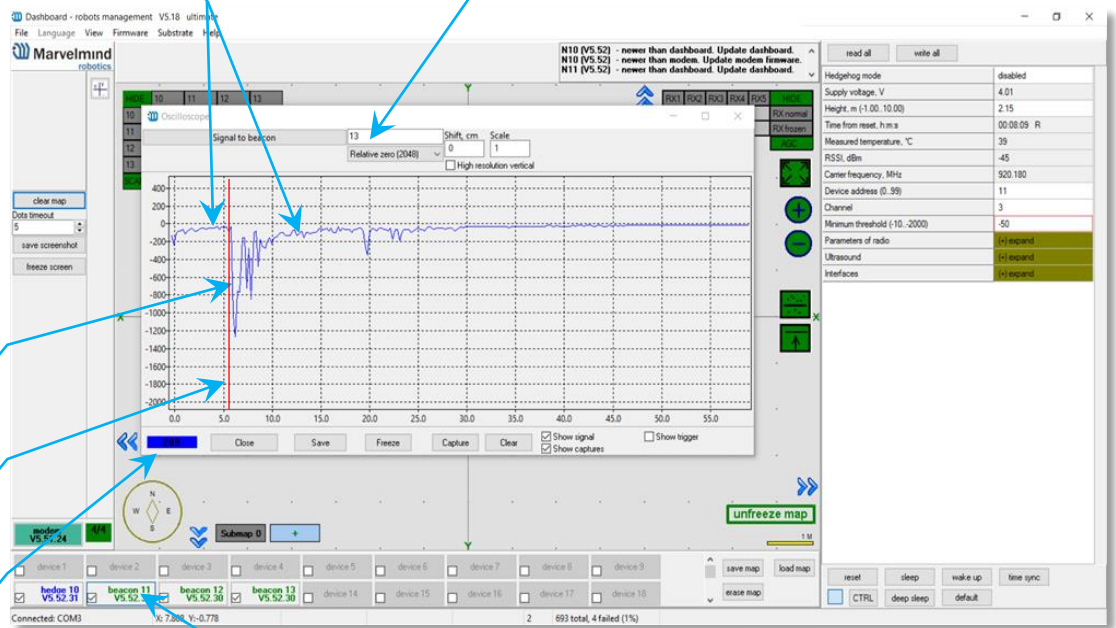

9.7 Proper Ultrasonic Signal Detection



This chapter mostly related to HW v4.9 beacons. Super-Beacons, Industrial Super-Beacons have high-power digital microphones for noise filtering and proper signal detection. Anyway, if you have problems with signal detection, read this chapter no matter which beacons do you use

These recommendations suitable only for NIA

Marvelmind Indoor Navigation System uses proprietary multi-frequency for ultrasonic signal and employs additional filtering to combat external noise. This also makes the system rather immune against the “usual suspects.” However, if the external noise is too strong, its source is too close, or it’s emitting a strong signal on frequencies close to 19, 25, 31, 37, 45kHz or white noise, the system functionality can be affected.

When external noise is high, identify the source. Usual sources include:

- Ultrasonic-based volume or movement detection alarm systems
- Other robots using ultrasonic
- Parktronics
- Sources of very strong white or impulse noise (air guns, air press, cutters, vacuum cleaner, etc.)
- Rotors of drones/copters

The best things to do in this case:

- Identify the beacons that are affected. Usually, they are those that are the closest to the source of noise. Try to reposition them
- Manually reduce the gain of the affected stationary beacons so that the signal from the mobile beacon would have a 1000–1800 amplitude. That would give the best signal-to-noise ratio. Don’t make the gain too high. The noise will be amplified, but the desired signal will be saturated and signal-to-noise ratio will be poor
- Input distances between beacons manually. More information – [Table of distances](#)

The gain settings may be very non-linear. There is almost no change at 4000 to 3000. But around 2500, the gain starts reducing very quickly (1200 – for some HW versions). By setting the gain manually, it is possible to find the optimal gain to obtain the highest signal to noise ratio so the system can work even in very challenging external conditions.

When the map is formed, only the mobile beacon is emitting, whereas stationary beacons are not. Thus, it does not matter how close the mobile beacon is to the source of the noise. However, it matters how close the stationary beacons are to those sources. Select the positions of the stationary beacons accordingly - place them further away from the noise sources.

9.8 Using hedgehog.log file

- The system automatically records all measured positions in the hedgehog.log file that is stored in the same folder as the Dashboard.exe file
- The data is written in csv format; each line describes the position of one of the hedgehogs at a certain moment
- The line format is described [here](#).



9.9 System Accuracy Evaluation

Accuracy of distance measurement.

- Marvelmind navigation system can measure distances between beacons with accuracy of +/- 2cm if correct ultrasound speed is used.
- The ultrasound speed depends on several factors: temperature, pressure, and humidity. Other factors have an insignificant effect.
- The main factor is temperature. In temperature range of -20...+50 °C the speed of ultrasound changes on about 0.6 m/ (s* °C). It gives distance error about $(0.6 / 340) * 100\% \sim 0.17\% / \text{°C}$. So caused by incorrect temperature setting absolute error of distance measurement is 0.17% of real distance between beacons. For example, with distance 30 meters and 5 °C error, this gives $0.85\% * 30 \sim 0.25$ meters' error. Marvelmind system allows to setup temperature of air in the system settings.

Accuracy of position measurement.

- Marvelmind system uses trilateration algorithm to calculate position by distances. The inaccuracy of position calculation is related to inaccuracy of distances measurement and to geometry of relative location of stationary and mobile beacons
- Basic trilateration formulas are given in this article: <https://en.wikipedia.org/wiki/Trilateration>
- As you see, the position of mobile beacons **X**, **Y**, **Z** is calculated from positions of 3 stationary beacons which are set by values of **d**, **i**, **j**. One of the beacons was shifted to (0,0) position to simplify formulas in the article. In formulas for **X**, **Y** we see **d** and **j** in denominators. This means that with low values of **d** and **j** small error of this value can cause significant position error
- Please see the picture of the beacons in the article - in more simple words, in means that if one of three beacons is close to line connecting other two beacons, it gives increased inaccuracy of locating mobile beacon
- For example:
 - assume $d= 10, i= 5, j= 0.1, r1= 7, r2= 7, r3= 4.8$
 - We get $x= 5, y= 2.4375, z = 4.25$
 - If we suppose that $j=0.101$ (0.1 cm error), we receive $x= 5, y= -0.06, z= 4.89$
 - You see very large Y error
- Another example for Z. Assume mobile beacon is relative close to plane of stationary beacons:
 - $d= 8, i= 4, j= 6, r1= 5.02, r2= 5.02, r3= 3.01$
 - This gives $X=4, Y= 3.01169, Z= 0.36$
 - If we suppose $r3= 3.0$ (1 cm error), we receive $X=4, Y= 3.016, Z= 0.44$. Error on Z is about 8 cm
- Also, with $r1= 5, r2= 5, r3= 3, Z$ will be 0. As you see, low change of distances causes large change of Z value near the plane.



9.10 Calibration of the accelerometer

To calibrate an accelerometer on your beacon with IMU, you can do the following steps:

- Connect the mobile beacon via USB to the Dashboard
- Make sure that the beacon has IMU on board: open **View / Accelerometer menu** and **view / gyro data**. In the presence of IMU graphics in these windows should display the angular velocity and acceleration when moving the mobile beacon (turn it in hands).
Close the window of the accelerometer and gyro data
- Open the calibration window: **View / calibrate the accelerometer**
- When calibrating, it measures the data of the free fall (gravity of the Earth) corresponding to each of the three axes X, Y, Z. The initial ones from these calculations remember the correction shifts indicated in the table as "Zero" and the correction factors indicated as "K"
- The switch at the right bottom of the window should be in the **AutoFill** position
- Before starting the calibration, click the **Reset** button at the top of the window - zeroing the current calibration results
- To calibrate: slowly, without jerking, manually turn the beacon in each of the 6 positions and keep it still for 1-2 seconds:
 - The starting position - the beacon lies on the table; the antenna is pointing upwards (calibration Z +)
 - The beacon is turned upside down, the antenna pointing down (calibration Z-)
 - The beacon is on the end, the sensor RX1 is pointing towards the table (calibration Y +)
 - The beacon rests on the end, the RX3 sensor points toward the table (calibration Y-)
 - The beacon rests on the end, the RX2 sensor is directed towards the table (calibration X +). In order not to interfere with the USB connector, the beacon can be placed on the edge of the table, so that the cable hangs down
 - The beacon rests on the end, the RX5 sensor points toward the table (calibration X-)
- In each measurement, the readings of the accelerometer are corrected by Zero and K.
At the end of the measurement of 6 points 7.1 ... 7.6, in the serviceable accelerometer Zero should be close to zero, and K close to 1, see the screenshot. If not - check if you forgot any of the points 7.1 ... 7.6.
- To save the results, click **Calibrate**.

Dashboard - robots management v5.69f ultimate

File Language View Firmware Help

Marvelmind

Accelerometer data

scale: auto 20 mg 100 mg 1000 mg 10000 mg

X
 Y
 Z
 Xav
 Yav
 Zav

Clear map
Data timeout: 500
Data size mode: default
Save screenshots
Freeze screen

Clear Save Close Averaging, samples: 1

Gyroscope data

scale: auto 100 1000 10000

X
 Y
 Z

AI
None
Full

Clear Close Turbo

device 1 device 2 device 3 device 4 device 5 device 6 device 7

Save map Load map

Reset Sleep Wake up Time sync Zero IMU

Dashboard: Update dashboard

Read all Write all

CPU ID	Copy to clipboard	12423D
Hedgehog mode	enabled	enabled
Inverse system	disabled	disabled
Distances only mode	disabled	disabled
Supply voltage, V	4.12	n/a
High voltage, V	n/a	n/a
Time from reset, h:ms	00:06:03	R
Measured temperature, °C	43	
RSSI, dBm	-74	
Radio frequency band	915 MHz	
Carrier frequency, MHz	921.066	
Device address (0..99)	23	
Channel	2	
Minimum threshold (-10..-2000)	50	
IMU	(+) expand	
Parameters of radio	(+) expand	
Ultrasonic	(+) expand	
Interfaces	(+) expand	
Georeferencing	(+) expand	
Misc. settings	(+) expand	
Hedgehogs pairing	(+) expand	

Accelerometer calibration

	X	Y	Z
Max	1010	1018	988
Min	-1019	-988	-1089
Delta	2029	2006	2077
Zero	-4	15	-50
K	0.986	0.997	0.963
15	1008	11	-63
14	1009	11	-75
13	1003	21	17
12	-16	-987	-25
11	-16	-988	-16
10	-15	-987	-32
9	-8	1013	-64
8	-11	1018	-63
7	5	45	985
6	0	41	986
5	0	42	988
4	-2	44	979
3	0	57	977
2	0	39	986

Reset

Calibrate

Save

Load

Clear table

save line

pause

manual fill
 auto fill

Number of averages: 20

Close

9.11 Settings to obtain correct north direction

- In some cases, it is necessary to obtain a correct north orientation of the map for NMEA output from Marvelmind system. For example, when using a Marvelmind mobile beacon as the navigation data source for Pixhawk installed on a copter, correct north is required for correct yaw control of the copter. The Marvelmind system cannot determine north automatically, so the user should make corrections after building and freezing the map. It can be done in one of two ways:

1. Rotate the Marvelmind map using the dashboard, as shown on the attached screenshot



2. You can also view the video:

<https://www.youtube.com/watch?v=AsYXrtg7aVU&feature=youtu.be>

- Enter the angle correction (the angle shown on screenshot) on the Pixhawk side from the Mission Planner of APM Planner



- Refer to the parameter "BCN_ORIENT_YAW":

http://ardupilot.org/copter/docs/parameters.html?highlight=bcn_orient_yaw

The screenshot shows the Marvelmind dashboard interface. On the left, there is a table with columns labeled 'X', 'Y', and 'Z' for various beacons. The main area is a map with several beacons plotted. A red arrow points to the 'Submap rotation, degrees' field in the settings panel on the right, which is currently set to 0.00. A red text box explains that the angle 'A' should be entered in this field to align north directions, and it should be negative to achieve clockwise rotation. A green arrow points to the 'Real North' direction on the map, and a blue arrow points to the 'Marvelmind North' direction, which is aligned with the Y-axis.

- Beacons may issue raw sensor data. To learn how to obtain this data, please check this protocol:

https://marvelmind.com/pics/marvelmind_beacon_interfaces.pdf

- You can receive the data byte-by-byte and check for the required packet header

- See an example here:

http://www.marvelmind.com/downloads/2017_02_08_C_example.zip

9.12 Communication of Pixhawk with Marvelmind mobile beacon

The Marvelmind mobile beacon can be connected to Pixhawk (and to any other hardware or software that inputs GPS according to the NMEA0183 protocol). The mobile beacon can send GPS data via UART and USB (virtual UART) interfaces. For further explanation, please check out this [document](#).



9.13 Sending path to robot

1. The dashboard sends request to modem via USB.
Procedure of sending these requests in dashboard is shown on second screenshot.
This format of request is described in section 8 of modem protocol:
https://marvelmind.com/pics/modem_usb_protocol.pdf

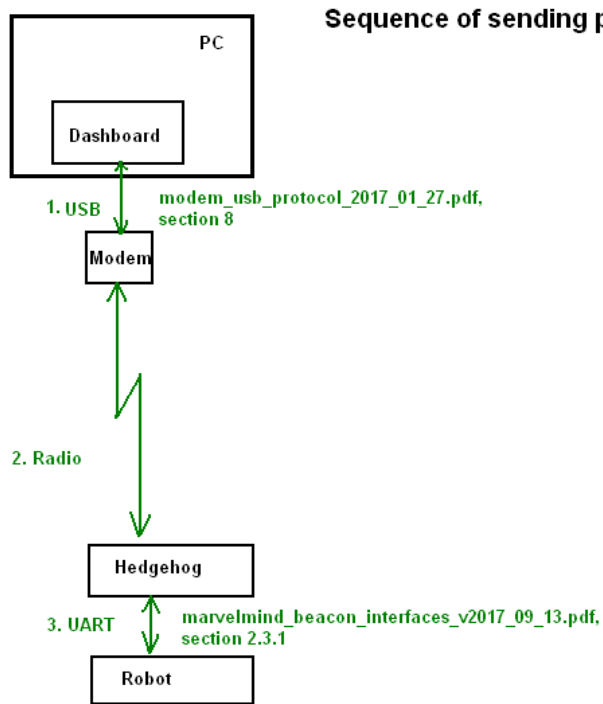

Modem transmits data to the hedgehog via radio, using our proprietary protocol

- the hedgehog communicates with robot via UART. Hedgehog sends data according to section 2.3.1 of this protocol:

https://marvelmind.com/pics/marvelmind_beacon_interfaces.pdf

The robot should confirm receiving data by response packet shown in section 2.3

This communication on the robot side is implemented in the Arduino example on our site. As you can see in the protocol, robot should not request the waypoints, the hedgehog will send the waypoints when they will be transmitted from dashboard. But robot should confirm receiving each waypoint by this packet:

[0x03,0x47,0x01,0x02,0x00, <2 bytes of checksum>]

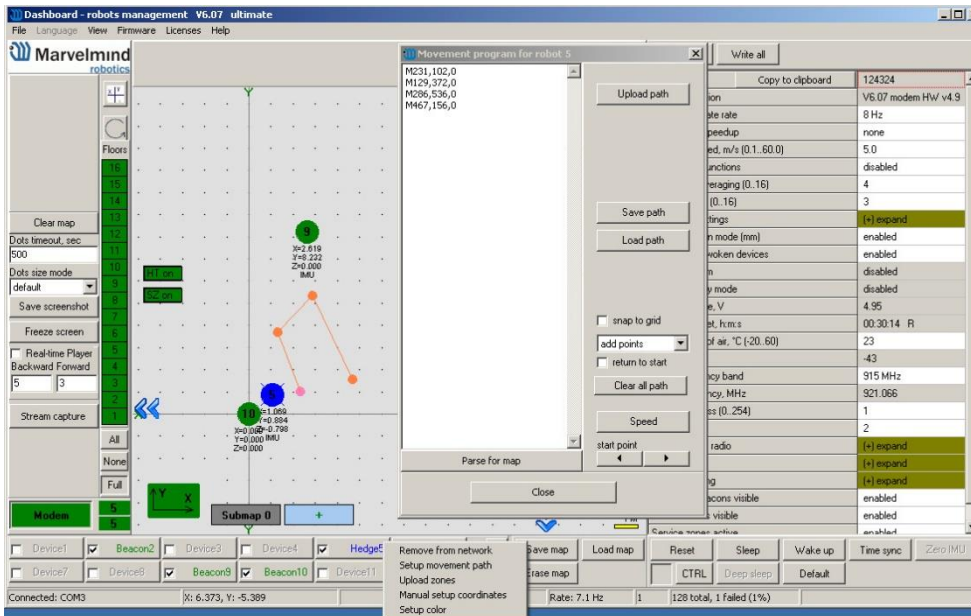

How to send a path:

- Choose mobile beacon in the dashboard

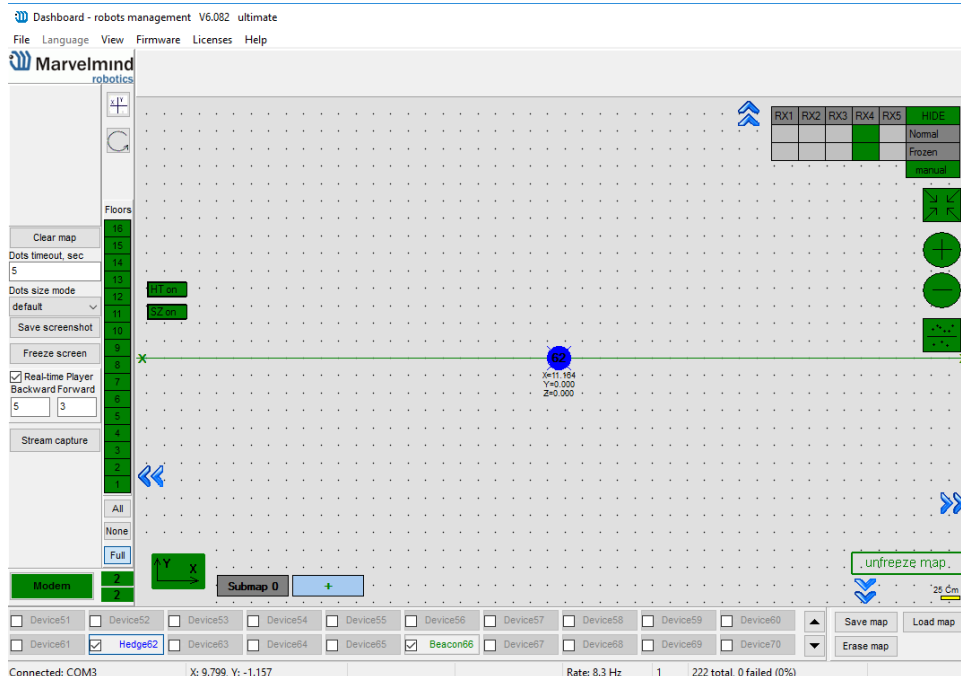

– Right mouse button on it -> Set movement path

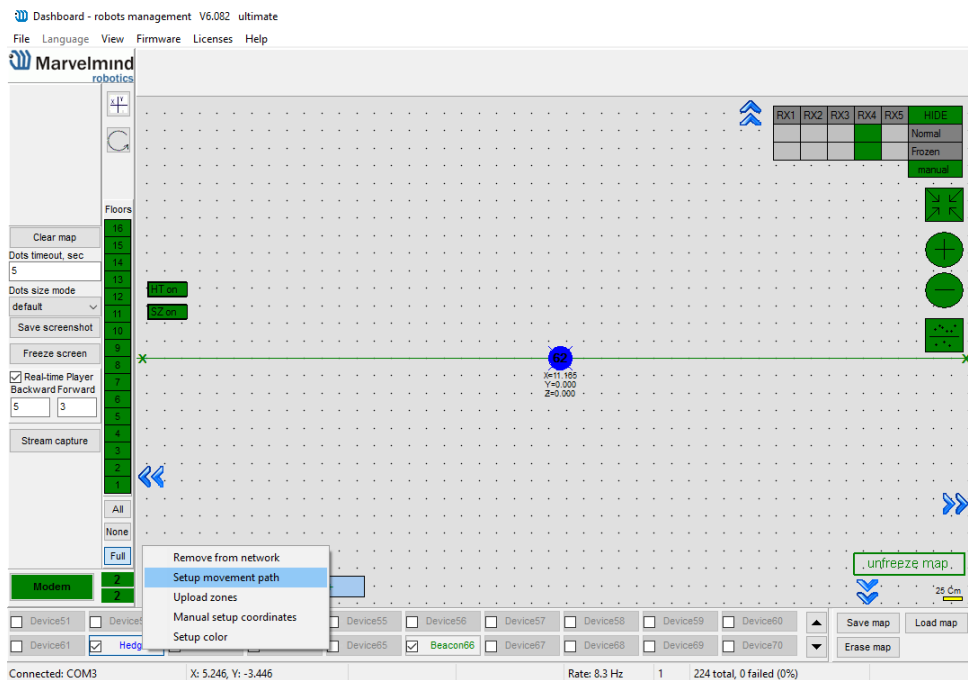

– Shift+Left mouse click to add point

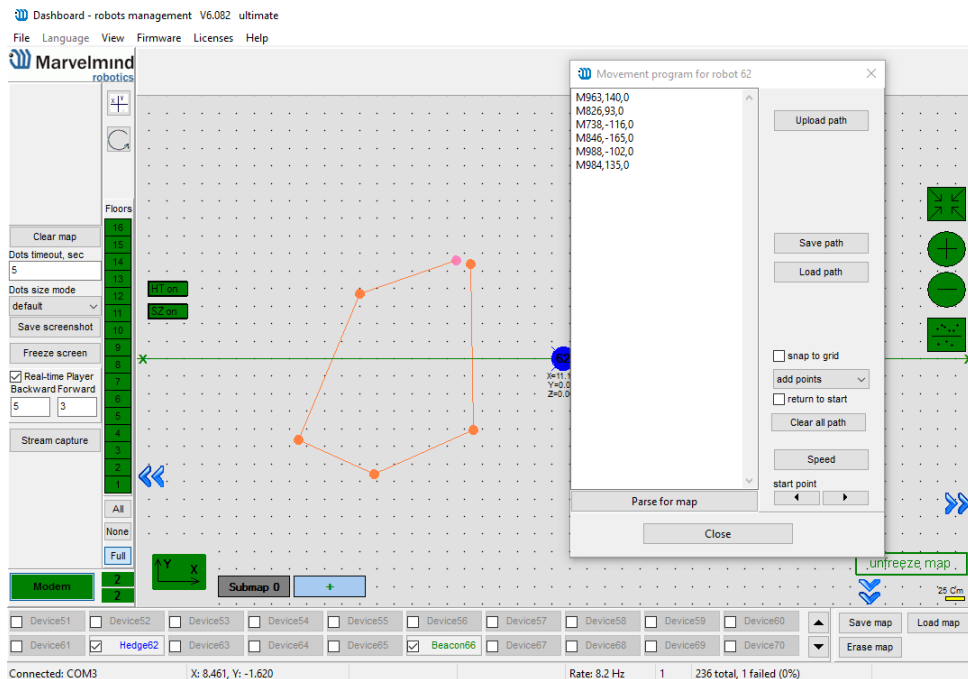

- **Shift+Left mouse click on point, to remove that point**

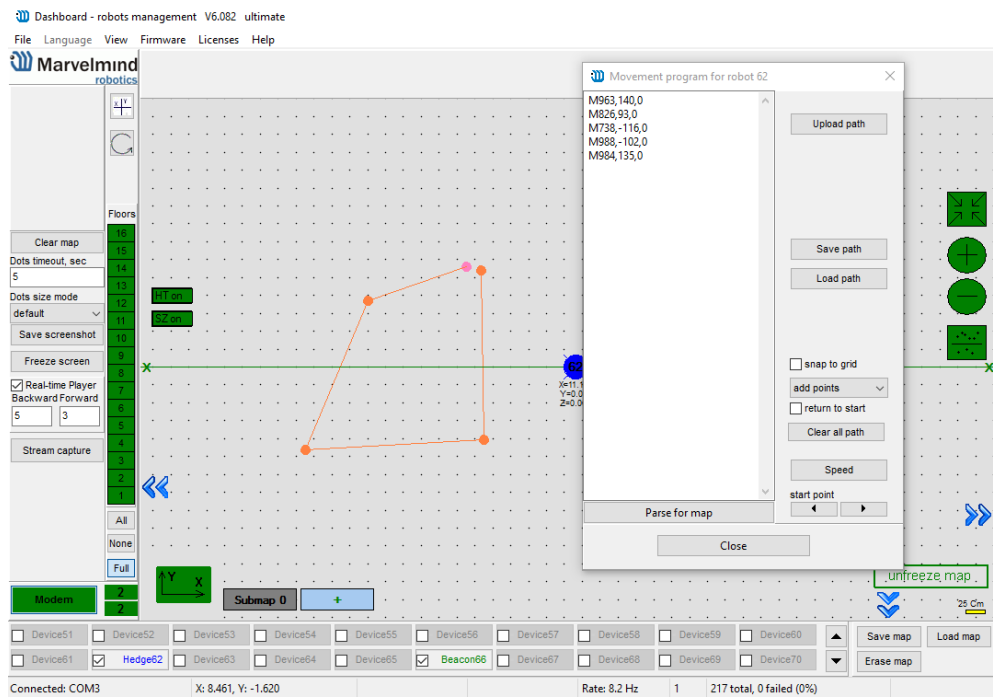

- **Click on Upload path to send it to robot**

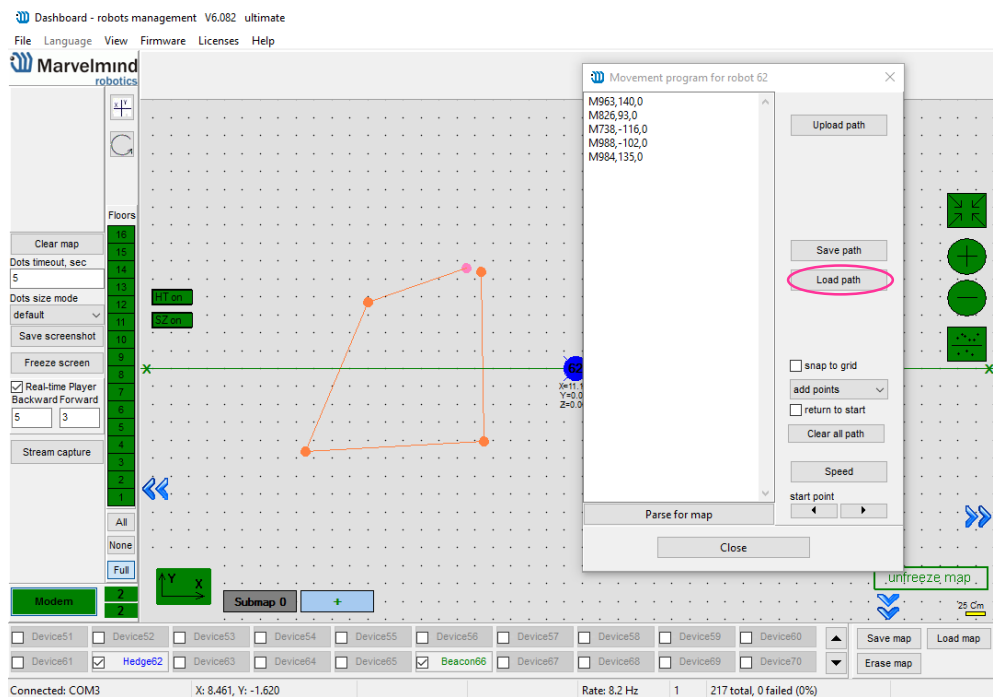

- **Path loaded**

9.14 Proper ultrasonic coverage



The single most important requirement for the system to work well is to have proper ultrasonic coverage

Each sensor has an ultrasonic beam of ~90 degrees. Outside of that range, the emitting power and sensitivity drops quite rapidly. From the left, right, or back of the ultrasonic sensor, the signal is highly attenuated. Thus, it is crucial to provide proper ultrasonic coverage for the area where the robot will be moving.

- It is also very important to provide proper ultrasonic coverage to the stationary beacons when the map is being formed
- **Mobile beacon (“hedgehog” or “hedge”)** is designed to be placed horizontally
- The mobile beacon has four horizontal and one vertical sensor, each covering its own sector. Together, they cover 360 degrees horizontally and 180 degrees in the upper hemisphere. The lower hemisphere is highly attenuated, so don't expect ultrasonic coverage in that area
- It is advised that the mobile beacon be placed as high as possible on the robot if the stationary beacons are above the mobile beacon. This minimizes shadows from other objects, people, etc.

The screenshot displays the Marvelmind robotics management interface. The main window shows a 2D map with several beacons and a mobile beacon (hedgehog). A table in the top-left corner provides coordinates for beacons 22 through 26. The configuration panel on the right shows various radio and system settings.

beacon	22	23	24	25	26
22		10.262	10.398	6.618	
23	10.262		9.993	4.853	
24	10.398	9.993		11.345	
25	6.618	4.853	11.345		
26	6.991	3.699	9.947	2.003	

Configuration Panel (Right):

- Hedgehog mode: disabled
- Supply voltage, V: 3.70
- Height, m (-10.000..10.000): 1.850
- Time from reset, h.m.s: 00.05.08 R
- Measured temperature, °C: 39
- RSSI, dBm: -50
- Carrier frequency, MHz: 433.400
- Device address (0..99): 25
- Channel: 0
- Minimum threshold (-10..-2000): -50
- Parameters of radio: (collapse)
- Base frequency, MHz: 433.400
- Radio profile: 38 Kbps
- Device address (0..99): 25
- Channel: 0
- Modulation: GFSK
- Power of TX (0..255): 192
- Channel spacing, KHz (25.391..405.457): 49.194
- Intermediate frequency (ID), KHz (0..787): 152
- Offset frequency, KHz (-203.13..201.54): 0.00
- Deviation frequency, KHz (1.587..380.859): 14.282
- Channel bandwidth, KHz (58.036..812.500): 101.563
- CCA mode: always
- DC blocking filter: enabled
- Manchester: disabled
- Whitening: enabled



- Example of proper positioning of the mobile beacon can be found here: <https://youtu.be/PFgNPkLGCDk>
- The beacon is placed horizontally and above other objects that can cast a shadow on the stationary beacons
- **Keep the radio signal's strength under control**
- The RSSI (Dashboard => right menu) of any beacon/modem must not be higher than -25dBm. Otherwise, the system may malfunction

It is recommended the distance between the modem and beacons be no less than 0.5–1m. Beacons can be placed as close to each other as needed. If a beacon is extremely close to the modem, disconnect the antenna from the beacon. Monitor the Received Signal Strength Indicator (RSSI). It must be in the range of -25 to -70dBm. An RSSI of less than -70dBm will work too, but packet losses may start occurring. The quality of the radio connection very much depends on external interference as well because the used band is ISM (either 915MHz or 433MHz) and there are numerous co-existing systems.

Use 30 - 50 periods (pulses) in settings instead of the default 5.
Select:

Ultrasound settings => Number of periods

Ultrasound	(-) collapse
Mode of work	TX+RX normal
Analog power in sleep	enabled
Power after transmission	not turn off
Frequency, Hz (100..65000)	31000
Duty, % (1..99)	50
Number of periods (1..100)	5
Amplifier limitation (calibrated)	4000
Amplification	AGC
AGC desired level (-1800..0)	-500
AGC hysteresis (10..2000)	130
AGC step, dB (1..20)	3
Mode of threshold	automatic
Minimum threshold (-10..-2000)	-50

When you have large errors in position estimation (more than a 1m inaccuracy), use the embedded Oscilloscope on **Dashboard => View** to determine which stationary beacon is jammed

Reduce the gain of the ultrasonic manually depending on your system

9.15 Sensors settings: example for 2D and mobile beacon

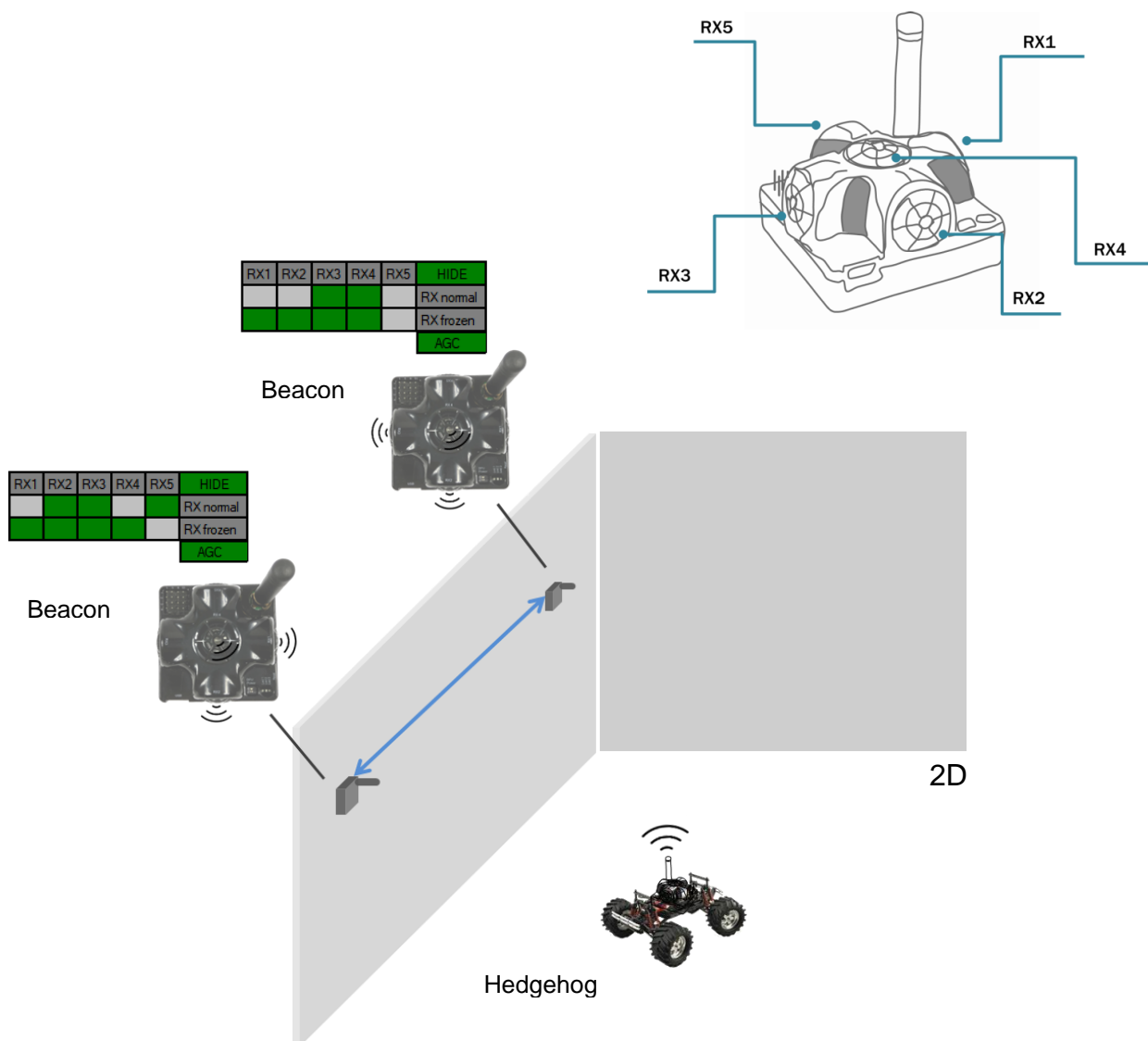

Beacon 2

RX1 and RX4 emit ultrasound in normal mode for better ultrasonic signal exchange with Beacon 3. In frozen mode RX2 added as working sensor. The rest sensors are turned off

Changing sensors' settings could be found in the panel in the upper right corner of the Dashboard during your beacon is connected to the computer

Beacon 3

RX3 and RX4 emit ultrasound in normal mode for better ultrasonic signal exchange with Beacon 2. In frozen mode RX2 added as working sensor. The rest sensors are turned off

9.16 Powering beacons



Depending on the type of beacon, may be internal battery, or external USB power supply, for more details check [comparison table](#)

Battery lifetime totally depends on the mode of operation and can be varied between several days to several months (or more for special applications)

10. Frequently Asked Questions



Please check this [forum](#) for more information. Here we will answer the most common questions

1 What is the proper way to place the beacons?

- The actual distance between beacons must be $\leq 30\text{m}$. Provide the line of sight from one beacon to minimum two others

2 How far can beacons be located from modem?

- In the open space the distance from the modem to the beacon can reach several hundred meters

3 What if hedgehog shown as **orange** circle or **transparent** inside in the Dashboard?

- **Blue** - normal mode and confident tracking
- **Orange** - system provides the best location data possible, but confidence is lower, than blue
- **transparent** - lost radio packets or no ultrasound coverage

4 What is the obstacle for ultrasound?

- The real obstacles for ultrasound are walls (concrete), glass, metal. If you need to cover a multiple-floor territory you can use our Submap feature in which case the tracking will not be interrupted

5 How the system works in very low and very high temperatures?

- System is designed for normal office-like conditions and temperatures $0\text{ }^{\circ}\text{C}$ - $40\text{ }^{\circ}\text{C}$
- You can see some other types of beacon (outdoor, explosion safe, etc.) in the [comparison table](#)
- We also possible to produce some special versions, which will suit your case. Please write to info@marvelmind.com



6 Are beacons resistant to explosions, dust, dirt, water, noise?

- Low-frequency noise (motor noise, industrial equipment) does not interfere with the normal operation of the system
- You can see some other types of beacon (outdoor, explosion safe, etc.) in the [comparison table](#)



7 What is the time of delay between positioning the object and respond?

- The delay is directly proportional to the update rate. For example, if update rate is 16 Hz delay is $1.2:1.5 \times 60\text{ms}$
- The limit is $1.5x$ times the maximum distance between the stationary beacons. To expand the service area, please follow the instructions shown in the attached screenshot. Notice that positioning the mobile

beacon far from stationary beacons and close to their plane may result in increased positioning error because of bad geometry of measurement

8 How to define IMU or not IMU beacon?

- Check white sticker on the box and on the beacon's bottom /IMU - with IMU
- Connect beacon via USB: Dashboard => View => Accelerometer data

9 Can we use none-IMU beacon as mobile beacon or not?

- Yes, you can (<https://www.youtube.com/watch?v=A4aRsjH2-E>)

10 What is the reason to choose 915Mhz vs 433Mhz?

- The 915MHz version is designed for the US, Canada and Americas in general. The ISM band (license-free band for industrial, science and medical applications) in those countries is 915MHz
- In Europe, it is 433MHz

11 Device do not connect via USB?

- Use USB cable with long metal part. If you have any problems with USB connection, change the cable first. One cable can work for one device and do not work for other

12 Does the orientation of the beacon matter?

- Yes, it is. Place and orientate it in positions, where sensors can "hear" each other. v4.9 beacon has $\approx 90^\circ$ per sensor coverage([illustration](#)), Mini-RX and Industrial-RX have $\approx 180^\circ$ coverage([illustration](#))

13 Why Dashboard do not see more than 4 beacons

- System has a limitation of 4 beacons per submap. If you have more than 4 beacons, just create another submap, and beacons will appear

11. Troubleshooting checklist

If you have any problems with the system, follow these simple steps:

- **Update SW** on modem and beacons

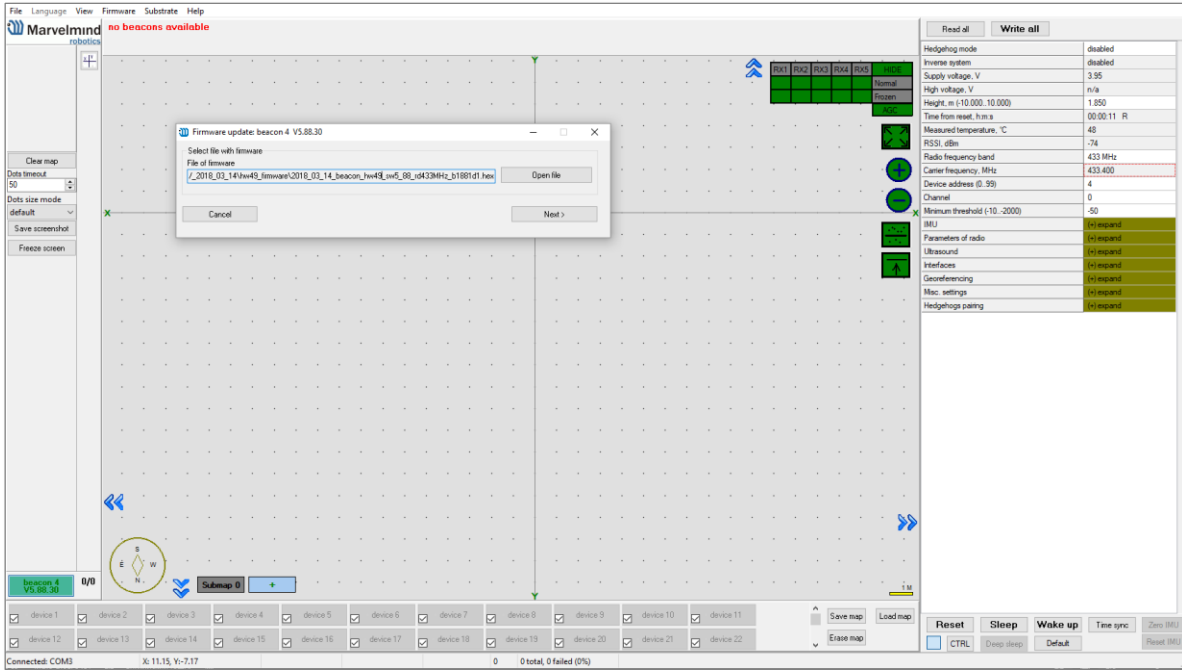

- Now, connect all beacons and modem one by one and press **Default** button in the Dashboard (When updating the SW, please, press **Default** button to make sure that beacons really have default settings. Otherwise, modem may be calling on a wrong channel or something)
- Press **Erase map**

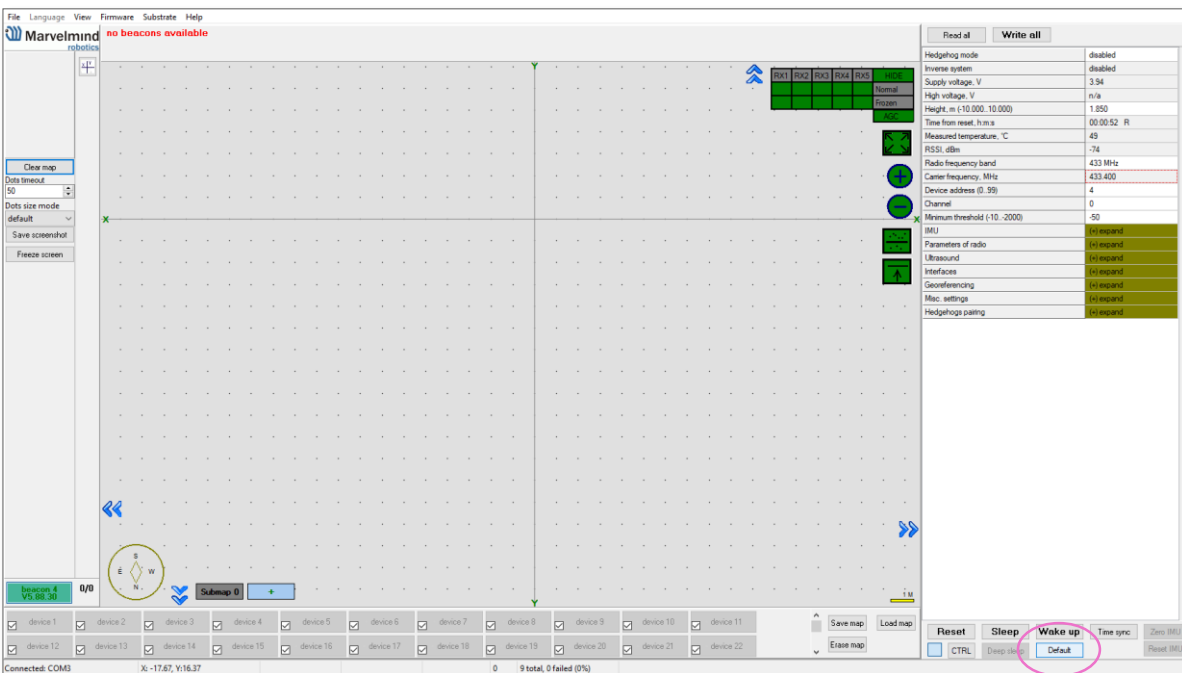

Checklist before starting the system:



IA and NIA SW differs

For IA you should use stationary beacons with **different frequencies**

- Make sure that you use correct SW. Inverse Architecture(IA) SW for Inverse system, Non-Inverse Architecture(NIA) SW for Non-Inverse system ([Architectures comparison](#))
- Make sure that your beacons are 3.5V and higher before using. If not, charge it for 2-3 hours.
- Keep modem 1-2m away from beacons. if closer, the beacons radio may be overloaded
- Antenna's recommendations:
 - The antenna must be kept as straight as possible. Otherwise it will reduce the effective range
 - The antennas must be kept away from conductive materials, such as metal and carbon by at least a half inch
 - Keep the antennas away from the motors and other noise sources as much as possible
- Use USB cable with long metal part. If you have any problems with USB connection, change the cable first. One cable can work for one beacon and do not work for other
- Be sure that you use SW from the same pack
- When updating the SW, please, press Default button to make sure that beacons really have default settings. Otherwise, modem may be calling on a wrong channel or something
- Start with simple configuration (10x10m square, 4 stationary beacons)
- Do not obstruct line of sight between beacons
- Build the map first, freeze it, then wake up the "hedge"
- Number of periods. By default – 5; For longer distances, you shall put it 10-50

Mini-RX beacon may be over discharged. In that case do the following:

- Turn off the beacon with DIP switches
- Charge it for 1 hour
- Turn the beacon on, flash the latest SW via DFU Programming and charge it for 1 hour again

12. Contacts

For additional support, please send your questions to info@marvelmind.com