

TABLE 1				
PART NUMBER	CABLE PART NUMBER	"A" REF (SEE NOTE 16)	"B" ± 50[2.0] (SEE NOTE 17)	Ø "C" REF
SCPU-17-G-2.00, -AMS, -AM, -BMS, -BM	UCA-02-01	2.00M [78.74]	2.04M [80.18]	4.8[.189]
SCPU-17-G-3.00, -AMS, -AM, -BMS, -BM	UCA-03-01	3.00M [118.11]	3.04M [119.55]	5.0[.197]
SCPU-17-G-5.00, -AMS, -AM, -BMS, -BM	UCA-03-01	5.00M [196.85]	5.04M [198.29]	5.2[.205]
SCPU-17-G-2.00, -BC	UCA-02-01	2.00M [78.74]	2.02M [79.53]	4.8[.189]
SCPU-17-G-3.00, -BC	UCA-03-01	3.00M [118.11]	3.02M [118.90]	5.0[.197]
SCPU-17-G-5.00, -BC	UCA-03-01	5.00M [196.85]	5.02M [197.64]	5.2[.205]

**THIS PRODUCT MANUFACTURED WITH LEAD-FREE PROCESSING**

**DESIGNED & DIMENSIONED IN MILLIMETERS[INCHES]**

**SCPU-17-X-X.XX-XXX-XXX**

**PLATING**  
 -G: .000030" GOLD ON CONTACT AREAS, NICKEL ON SHELLS

**LENGTH**  
 -X.XX ("A", SEE TABLE 1)  
 (0.17M[6.69] MIN - 5.00M[196.85] MAX)

**END 1 OPTIONS**  
 -AMS: SEALED USB A (USB A END SEALED ONLY)  
 -BMS: SEALED USB B (USB B END SEALED ONLY)

**END 2 OPTIONS**  
 -AMS: SEALED USB A (USB A END SEALED ONLY)  
 -BMS: SEALED USB B (USB B END SEALED ONLY)  
 -AM: USB A NOT SEALED (USB A END NOT SEALED ONLY)  
 -BM: USB B NOT SEALED (USB B END NOT SEALED ONLY)  
 -BC: BLUNT CUT (SEE SHEET3)

**NOTE:**

-2.00, -3.00, AND -5.00 ARE CATALOG STANDARD LENGTHS. FOR OTHER LENGTHS (0.17M[6.69] MIN - 5.00M[196.85] MAX) CONTACT SAMTEC.

FIG. 1  
 SCPU-17-G-X.XX-AMS-BMS SHOWN

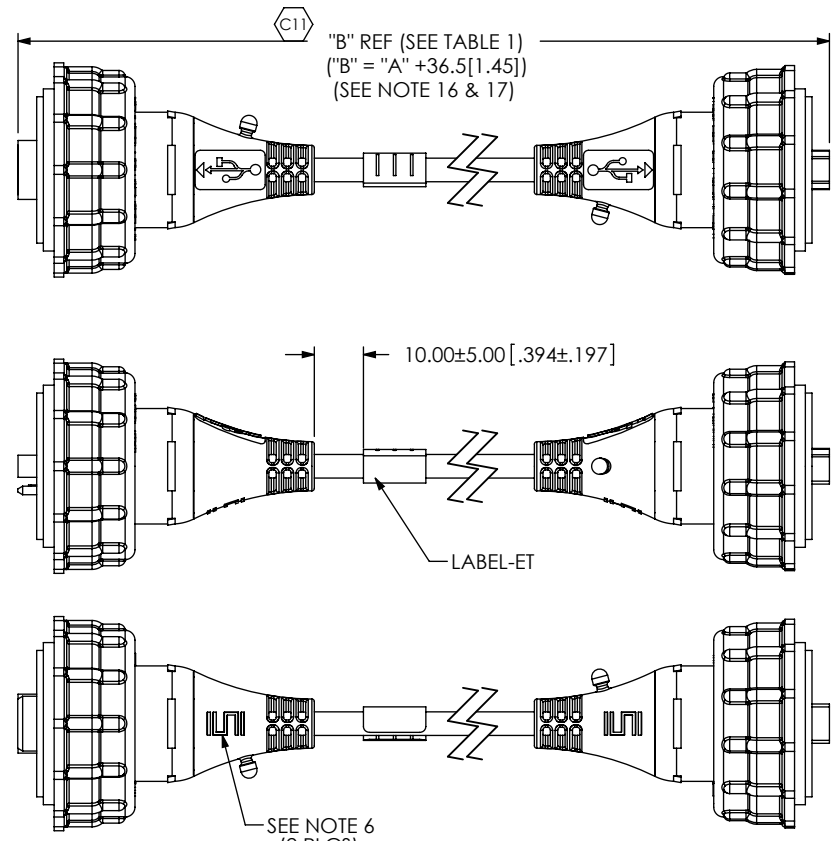



TABLE 6		
LENGTH RANGE	USE CABLE PART No.	O.D.
0.17M - 1.99M	UCA-01-XX	4.80
2.00M - 2.99M	UCA-02-XX	5.00
3.00M - 5.00M	UCA-03-XX	5.20

NOTES:

1. Ⓢ REPRESENTS A CRITICAL DIMENSION.
2. NOTE DELETED.
3. SURFACE TO BE RECESSED 0.22[.009].
4. USB LOGO TO BE RAISED 0.25[.010]. USB LOGO TO BE PRINTED IN WHITE.
5. USB LOGO'S TO BE ALIGNED TO USB CONNECTORS AS SHOWN.
6. SAMTEC LOGO TO APPEAR ON SURFACE AS SHOWN, APPROXIMATELY 4.50[.177] x 7.50[.295], RAISED 0.25[.010].
7. MOLDED SURFACES SHALL BE CONSISTENT AND SMOOTH. SURFACES TO BE FREE OF SCRATCHES, NICKS, SINK AREAS, VOIDS, OR OTHER BLEMISHES.
8. ALL MULTIPLE CAVITY MOLDS SHALL IDENTIFY EACH CAVITY WITH A NUMBER DESIGNATION LOCATED WHERE SHOWN.
9. ALL IDENTIFICATION MARKS MUST NOT STAND GREATER THAN 0.051[.002] OFF THE SURFACE OF THE PART.
10. MOLD TO BE INSERTED TO ACCEPT DIFFERENT CABLE DIAMETERS.
11. FINISHED ASSEMBLY TO BE 100% TESTED FOR OPENS AND SHORTS BEFORE PREMOLD AND AFTER FINAL ASSEMBLY. AFTER FINAL ELECTRICAL TEST, LABEL EACH ASSEMBLY WITH 1 LABEL-ET.
12. ALL EJECTOR PIN AND GATE LOCATIONS MUST BE APPROVED BY SAMTEC PRODUCT ENGINEERING.
13. ANY ADDITIONAL VOIDING AND/OR MODIFICATIONS TO VOIDING MUST BE APPROVED BY SAMTEC PRODUCT ENGINEERING.
14. ALL DRAFT MUST BE WITHIN THE SPECIFIED TOLERANCES.
15. ALL INSIDE/OUTSIDE RADII 0.13 MAX UNLESS OTHERWISE STATED.
16. X.XX LENGTH IS EQUAL TO LENGTH ("A").
17. FOR ALL LENGTHS TOLERANCE SHALL BE ± 2% OF LENGTH.
18. ASSEMBLY TO BE SHIPPED IN BULK PACKAGING.
19. THIS IS A COMPONENT OF USBP-A-01-G-B-01 (CALLED OUT ON THE BOM), BUT LABELLED INDIVIDUALLY FOR ASSEMBLY PURPOSES.
20. THIS IS A COMPONENT OF USBP-B-01-G-B-01 (CALLED OUT ON THE BOM), BUT LABELLED INDIVIDUALLY FOR ASSEMBLY PURPOSES.
21. TORQUE SPECIFICATION FOR SCN-17-01 IS 12 IN-LBS.

UNLESS OTHERWISE SPECIFIED, DIMENSIONS ARE IN MILLIMETERS. TOLERANCES ARE: DECIMALS ANGLES 0.X: ±0.35 [.014] 0.XX: ±0.25 [.010] 0.XXX: ±0.15 [.006]	<b>PROPRIETARY NOTE</b> THIS DOCUMENT CONTAINS INFORMATION CONFIDENTIAL AND PROPRIETARY TO SAMTEC, INC. AND SHALL NOT BE REPRODUCED OR TRANSFERRED TO OTHER DOCUMENTS OR DISCLOSED TO OTHERS OR USED FOR ANY PURPOSE OTHER THAN THAT WHICH IT WAS OBTAINED WITHOUT THE EXPRESSED WRITTEN CONSENT OF SAMTEC, INC.	 520 PARK EAST BLVD, NEW ALBANY, IN 47150 PHONE: 812-944-6733 FAX: 812-948-5047 e-Mail: info@SAMTEC.com code: 55322
<b>MATERIAL:</b> DO NOT SCALE DRAWING SHEET SCALE: 1:1.33333 INSULATOR: GLASS FILLED THERMOPLASTIC CONTACTS: COPPER ALLOY SHIELDS: CRS, CABLE NUT: PA66 SEALED PREMOLD: LDPE/ SHOT WEIGHT 10.66 g [.0235 lb] NON-SEALED PREMOLD: N/A SEALED OVERMOLD: PA66 GF13 FR/ SHOT WEIGHT 12.71 g [.0280 lb] NON SEALED OVERMOLD: PVC/ SHOT WEIGHT 9.07 g [.0200 lb]	DESCRIPTION: SEALED CIRCULAR CABLE PLUG, USB DWG. NO. <b>SCPU-17-X-X.XX-XXX-XXX</b> BY: CHAD F 12/8/2004 SHEET 1 OF 10	

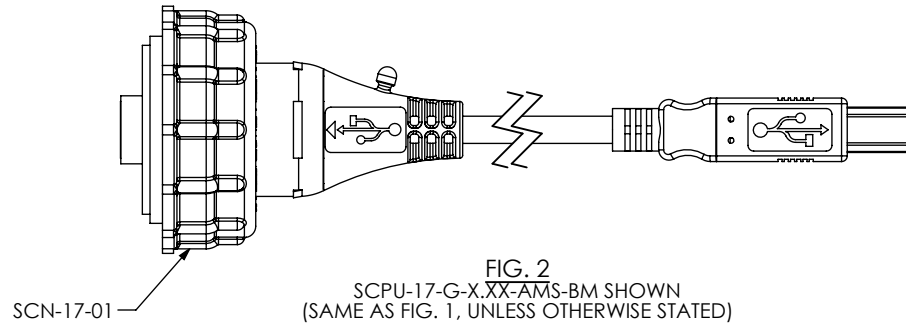

FIG. 2  
SCU-17-G-X.XX-AMS-BM SHOWN  
(SAME AS FIG. 1, UNLESS OTHERWISE STATED)

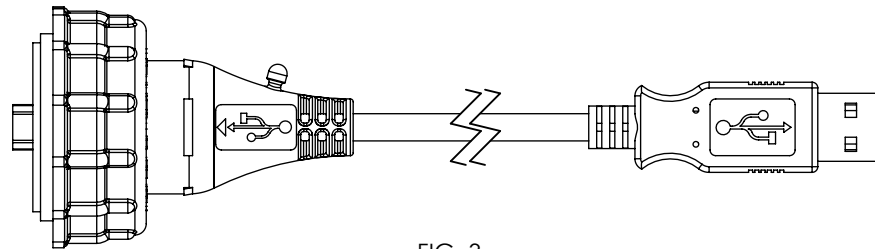
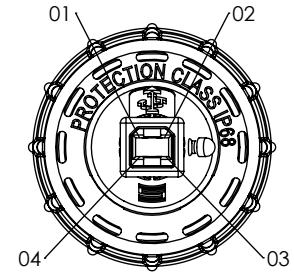
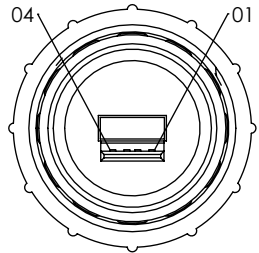
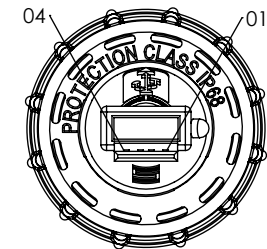
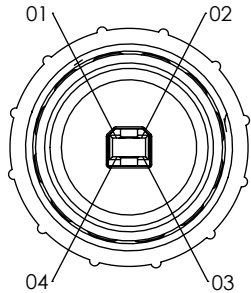

FIG. 3  
SCU-17-G-X.XX-BMS-AM SHOWN  
(SAME AS FIG. 1, UNLESS OTHERWISE STATED)



**PROPRIETARY NOTE**  
THIS DOCUMENT CONTAINS INFORMATION  
CONFIDENTIAL AND PROPRIETARY TO  
SAMTEC, INC. AND SHALL NOT BE REPRODUCED  
OR TRANSFERRED TO OTHER DOCUMENTS OR  
DISCLOSED TO OTHERS OR USED FOR ANY  
PURPOSE OTHER THAN THAT WHICH IT WAS  
OBTAINED WITHOUT THE EXPRESSED WRITTEN  
CONSENT OF SAMTEC, INC.

DO NOT SCALE DRAWING

SHEET SCALE: 1:1.33333

**samtec**

520 PARK EAST BLVD, NEW ALBANY, IN 47150  
PHONE: 812-944-6733 FAX: 812-948-5047  
e-Mail: info@SAMTEC.com code: 55322

DESCRIPTION:  
SEALED CIRCULAR CABLE PLUG, USB

DWG. NO.  
**SCPU-17-X-X.XX-XXX-XXX**

BY: CHAD F 12/8/2004 SHEET 2 OF 10

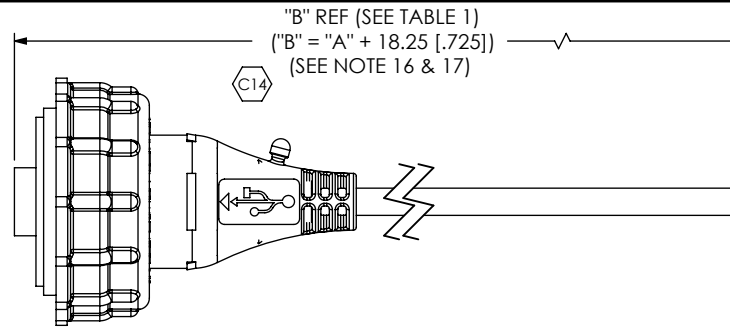
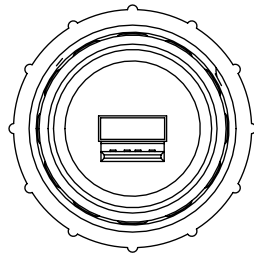

FIG. 4  
SCPU-17-G-X.XX-AMS-BC SHOWN  
(SAME AS FIG. 1, UNLESS OTHERWISE STATED)

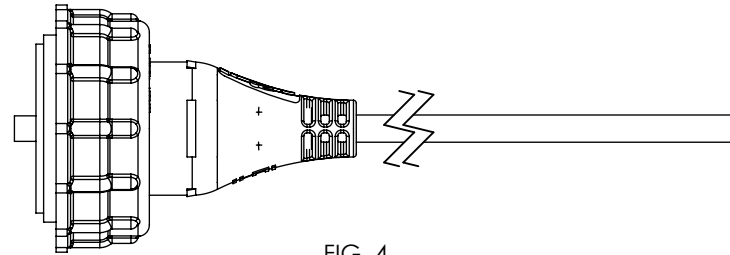
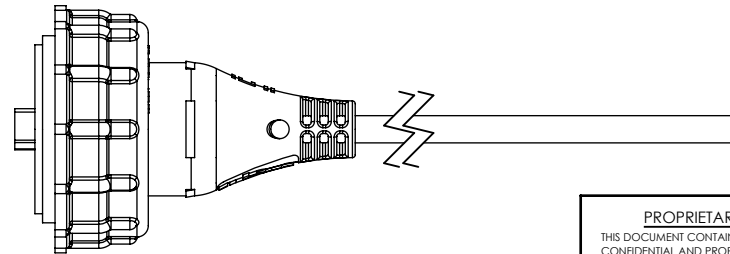
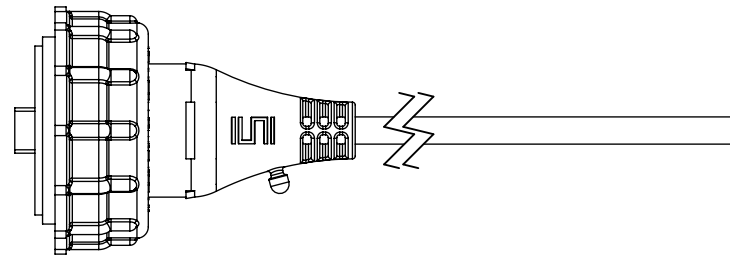
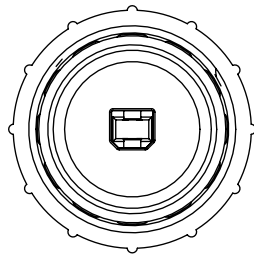

FIG. 5  
SCPU-17-G-X.XX-BMS-BC SHOWN  
(SAME AS FIG. 4, UNLESS OTHERWISE STATED)



**PROPRIETARY NOTE**  
THIS DOCUMENT CONTAINS INFORMATION CONFIDENTIAL AND PROPRIETARY TO SAMTEC, INC. AND SHALL NOT BE REPRODUCED OR TRANSFERRED TO OTHER DOCUMENTS OR DISCLOSED TO OTHERS OR USED FOR ANY PURPOSE OTHER THAN THAT WHICH IT WAS OBTAINED WITHOUT THE EXPRESSED WRITTEN CONSENT OF SAMTEC, INC.

DO NOT SCALE DRAWING

SHEET SCALE: 1:1.33333



520 PARK EAST BLVD, NEW ALBANY, IN 47150  
PHONE: 812-944-6733 FAX: 812-948-5047  
e-Mail: info@SAMTEC.com code: 55322

DESCRIPTION:  
SEALED CIRCULAR CABLE PLUG, USB

DWG. NO.  
SCPU-17-X-X.XX-XXX-XXX

BY: CHAD F 12/8/2004 SHEET 3 OF 10

**IN-PROCESS 1**  
(CUT TO LENGTH IN METERS)

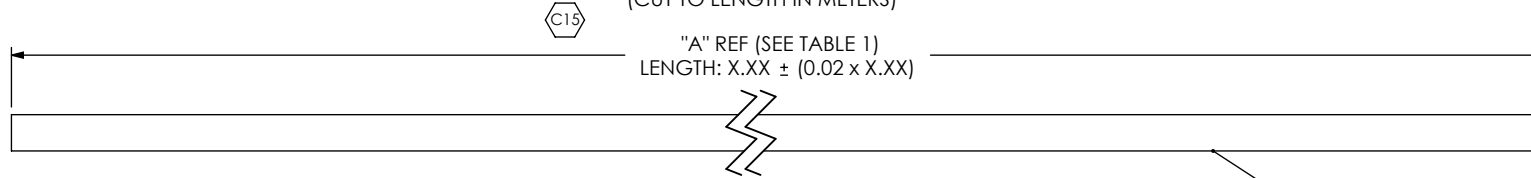

SEE TABLE 1

**IN-PROCESS 2**  
(STRIP JACKET)

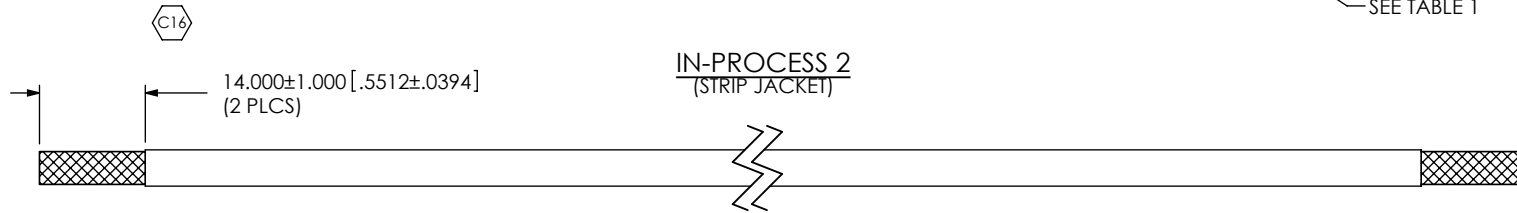

**IN-PROCESS 3**  
(FOLD SHIELD BACK, REMOVE FOIL AND TWIST SHIELD)

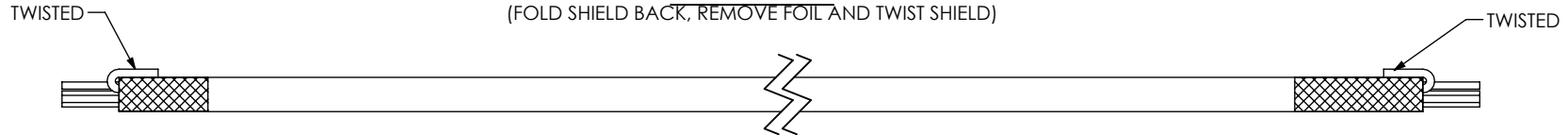

**IN-PROCESS 4**  
(STRIP INDIVIDUAL WIRES AND DIP IN TIN)

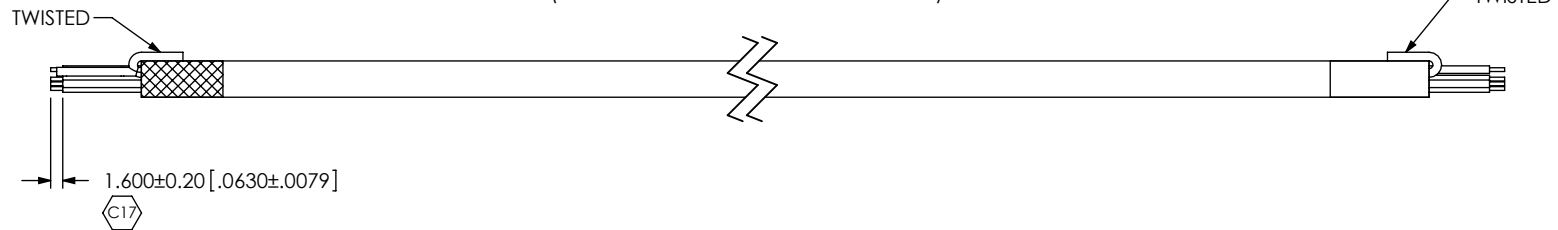

**PROPRIETARY NOTE**

THIS DOCUMENT CONTAINS INFORMATION CONFIDENTIAL AND PROPRIETARY TO SAMTEC, INC. AND SHALL NOT BE REPRODUCED OR TRANSFERRED TO OTHER DOCUMENTS OR DISCLOSED TO OTHERS OR USED FOR ANY PURPOSE OTHER THAN THAT WHICH IT WAS OBTAINED WITHOUT THE EXPRESSED WRITTEN CONSENT OF SAMTEC, INC.

DO NOT SCALE DRAWING

SHEET SCALE: 1:1.33333

**samtec**

520 PARK EAST BLVD, NEW ALBANY, IN 47150  
PHONE: 812-944-6733 FAX: 812-948-5047  
e-Mail: info@SAMTEC.com code: 55322

DESCRIPTION:

SEALED CIRCULAR CABLE PLUG, USB

DWG. NO.

SCPU-17-X-X.XX-XXX-XXX

BY: CHAD F

12/8/2004

SHEET 4 OF 10

**IN-PROCESS 5**  
TERMINATE TO SUB-USB-A-G-B-01 (SEE NOTE 19)

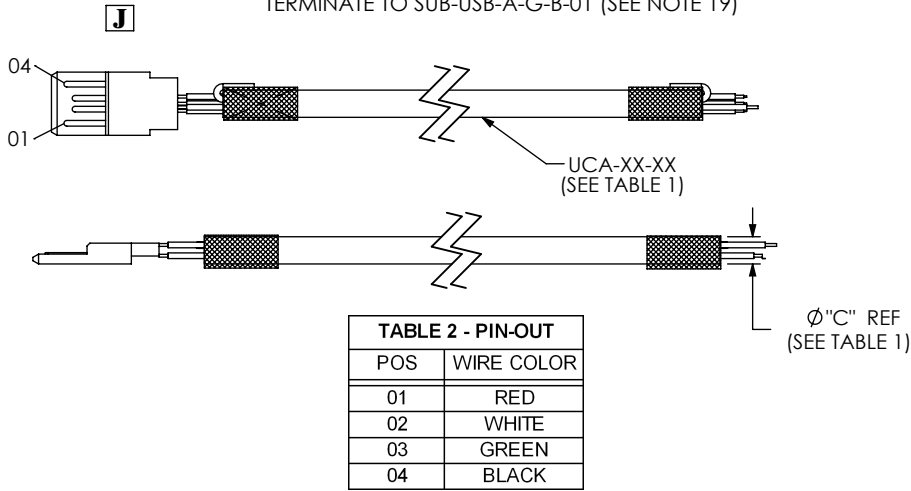

**IN-PROCESS 6**  
TERMINATE TO SUB-USB-B-G-B-01 (SEE NOTE 20)

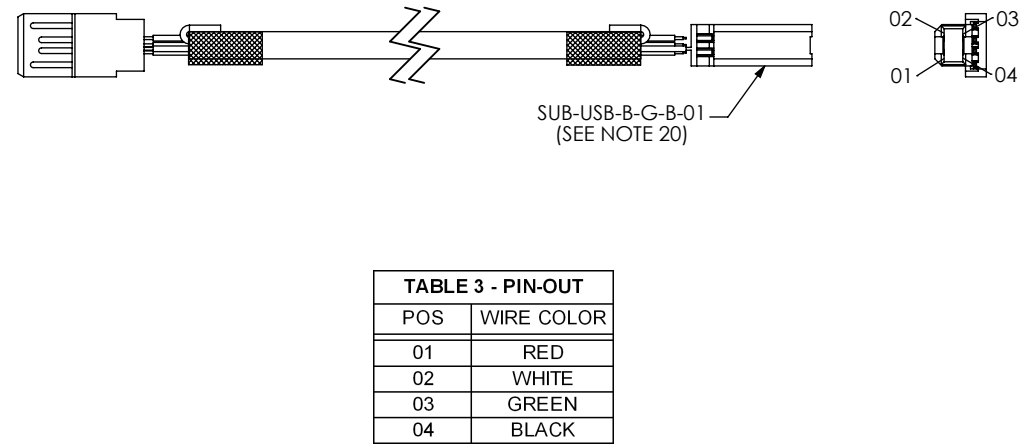

**IN-PROCESS 7**  
ADD USBS-A-N-01-01 (SEE NOTE 19) & USBS-B-N-01-01 (SEE NOTE 20) SHELLS

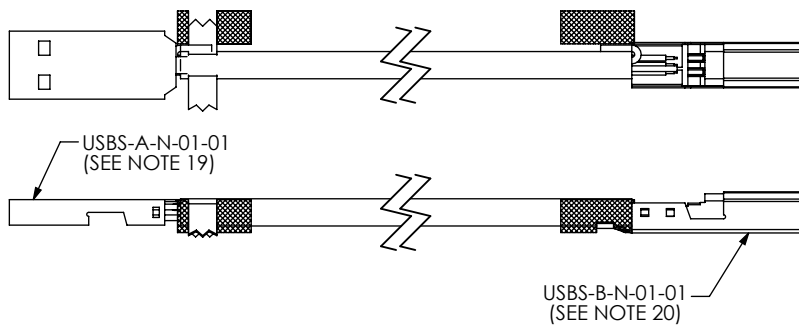

**IN-PROCESS 8**  
ADD USBS-A-N-02-01 (SEE NOTE 19) & USBS-B-N-02-01 (SEE NOTE 20) SHELLS

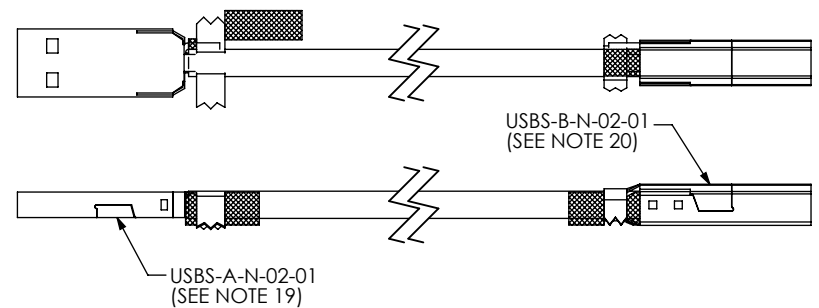

**IN-PROCESS 9**  
CRIMP SHELLS OVER BRAID AND ADD SOLDER SHIELD TO SHELL  
THEN FOLD GROUND WIRE "TWISTED SHIELD" OVER CRIMP AND SOLDER TO SHELL

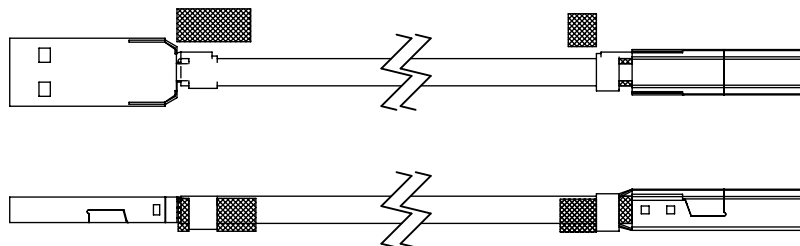

**PROPRIETARY NOTE**  
THIS DOCUMENT CONTAINS INFORMATION CONFIDENTIAL AND PROPRIETARY TO SAMTEC, INC. AND SHALL NOT BE REPRODUCED OR TRANSFERRED TO OTHER DOCUMENTS OR DISCLOSED TO OTHERS OR USED FOR ANY PURPOSE OTHER THAN THAT WHICH IT WAS OBTAINED WITHOUT THE EXPRESSED WRITTEN CONSENT OF SAMTEC, INC.

DO NOT SCALE DRAWING

SHEET SCALE: 1:1.33333



520 PARK EAST BLVD, NEW ALBANY, IN 47150  
PHONE: 812-944-6733 FAX: 812-948-5047  
e-Mail: info@SAMTEC.com code: 55322

DESCRIPTION:  
SEALED CIRCULAR CABLE PLUG, USB

DWG. NO.  
**SCPU-17-X-X.XX-XXX-XXX**

BY: CHAD F 12/8/2004 SHEET 5 OF 10

REVISION J

-AMS AND -BMS END OPTIONS  
IN-PROCESS 10  
PREMOLDING

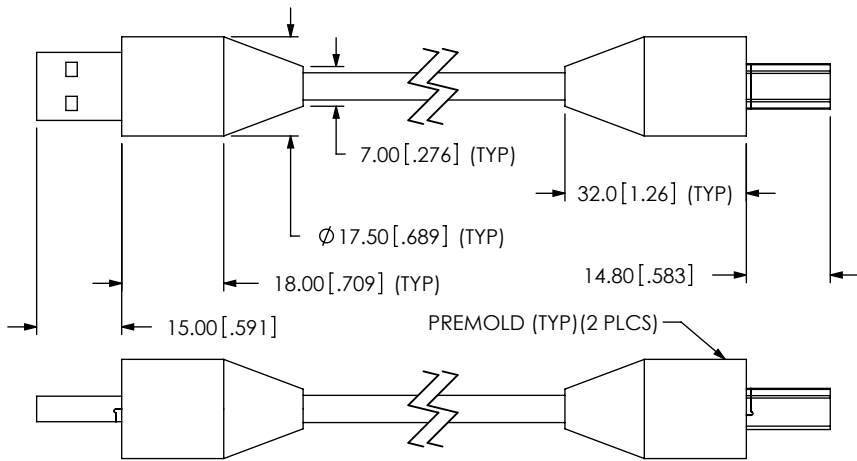

-AMS AND -BMS END OPTIONS  
IN-PROCESS 11  
ADD SCN-17-01

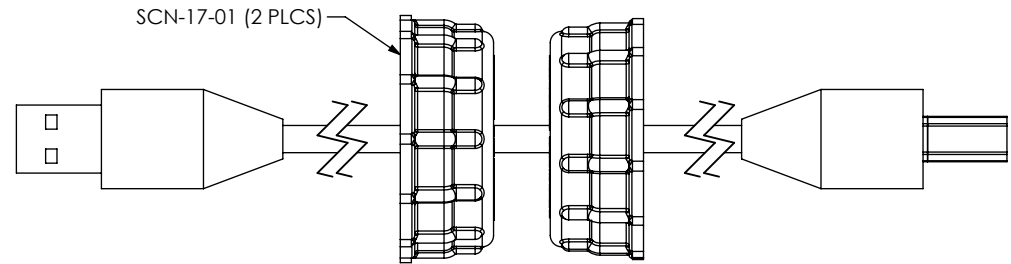

-AMS AND -BMS END OPTIONS  
IN-PROCESS 12  
OVERMOLDING

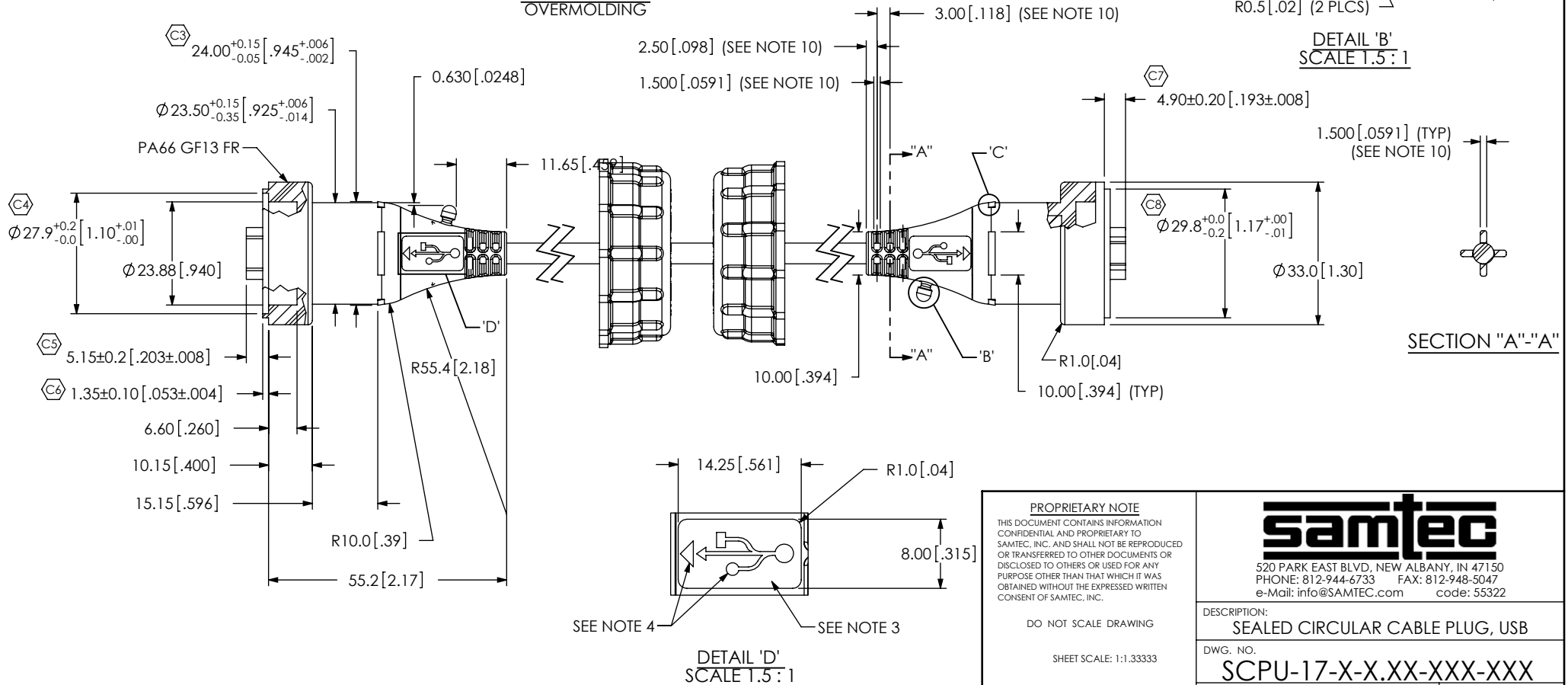

**PROPRIETARY NOTE**  
THIS DOCUMENT CONTAINS INFORMATION CONFIDENTIAL AND PROPRIETARY TO SAMTEC, INC. AND SHALL NOT BE REPRODUCED OR TRANSFERRED TO OTHER DOCUMENTS OR DISCLOSED TO OTHERS OR USED FOR ANY PURPOSE OTHER THAN THAT WHICH IT WAS OBTAINED WITHOUT THE EXPRESSED WRITTEN CONSENT OF SAMTEC, INC.

DO NOT SCALE DRAWING  
SHEET SCALE: 1:1.33333

<b>samtec</b>	
520 PARK EAST BLVD, NEW ALBANY, IN 47150 PHONE: 812-944-6733 FAX: 812-948-5047 e-Mail: info@SAMTEC.com code: 55322	
DESCRIPTION: SEALED CIRCULAR CABLE PLUG, USB	
DWG. NO. <b>SCPU-17-X-X.XX-XXX-XXX</b>	
BY: CHAD F	12/8/2004
SHEET 6 OF 10	

-BM END OPTION  
IN-PROCESS 10  
PREMOLDING

(SAME AS -AMS AND -BMS END OPTIONS IN-PROCESS 10, UNLESS OTHERWISE STATED)

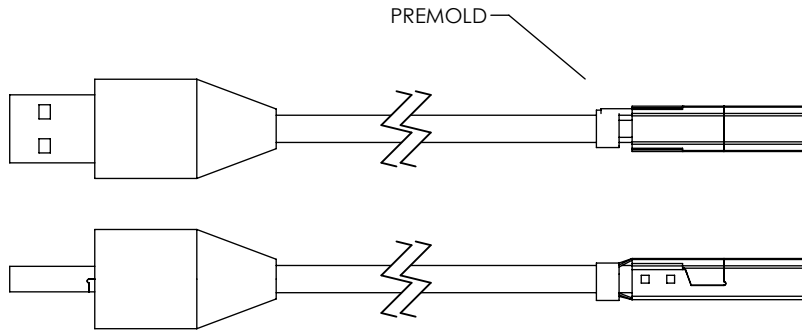

-BM END OPTION  
IN-PROCESS 11  
OVERMOLDING

(SAME AS -AMS AND -BMS END OPTIONS IN-PROCESS 11, UNLESS OTHERWISE STATED)

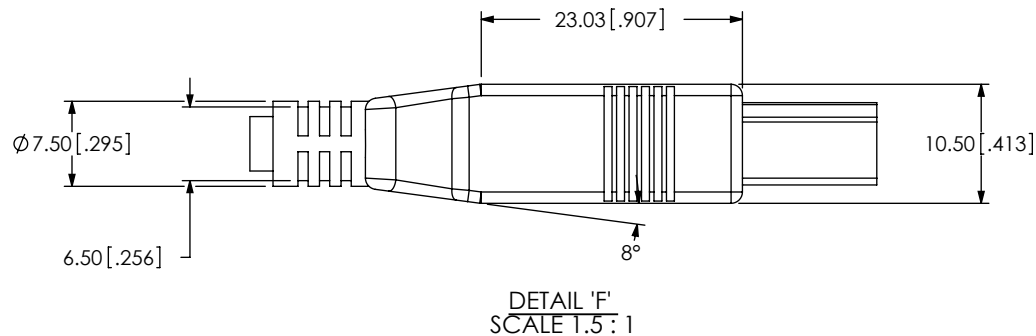
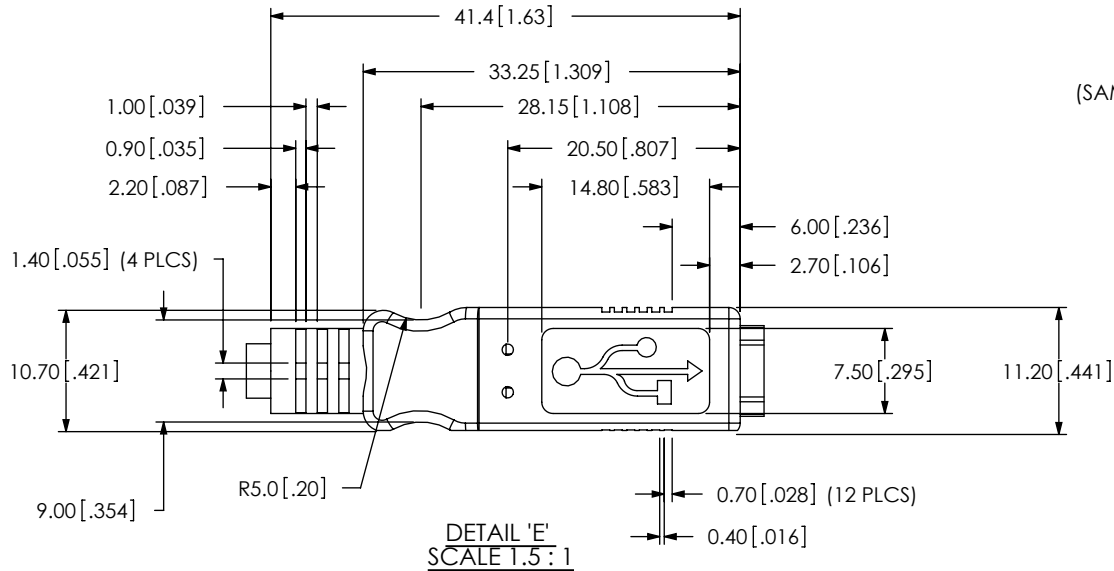
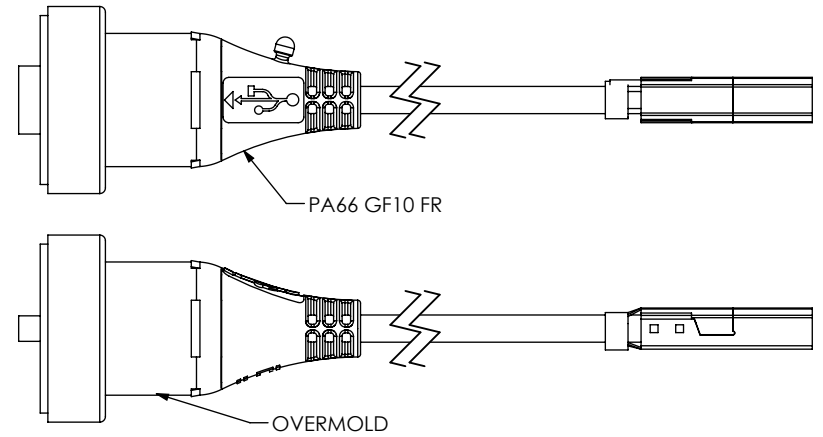

-BM END OPTION  
IN-PROCESS 12  
NON-SEALED OVERMOLDING

(SAME AS -AMS AND -BMS END OPTIONS IN PROCESS 12, UNLESS OTHERWISE STATED)

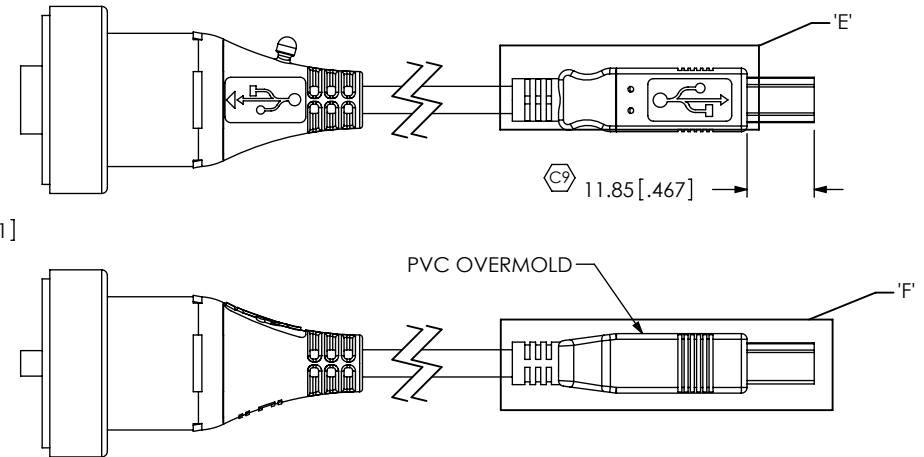

**PROPRIETARY NOTE**  
THIS DOCUMENT CONTAINS INFORMATION CONFIDENTIAL AND PROPRIETARY TO SAMTEC, INC. AND SHALL NOT BE REPRODUCED OR TRANSFERRED TO OTHER DOCUMENTS OR DISCLOSED TO OTHERS OR USED FOR ANY PURPOSE OTHER THAN THAT WHICH IT WAS OBTAINED WITHOUT THE EXPRESSED WRITTEN CONSENT OF SAMTEC, INC.

DO NOT SCALE DRAWING

SHEET SCALE: 1:1.33333

**samtec**

520 PARK EAST BLVD, NEW ALBANY, IN 47150  
PHONE: 812-944-6733 FAX: 812-948-5047  
e-Mail: info@SAMTEC.com code: 53322

DESCRIPTION:  
SEALED CIRCULAR CABLE PLUG, USB

DWG. NO.  
**SCPU-17-X-X.XX-XXX-XXX**

BY: CHAD F 12/8/2004 SHEET 7 OF 10

-AM END OPTION  
IN-PROCESS 10  
PREMOLDING

(SAME AS -AMS AND -BMS END OPTIONS IN-PROCESS 10, UNLESS OTHERWISE STATED)

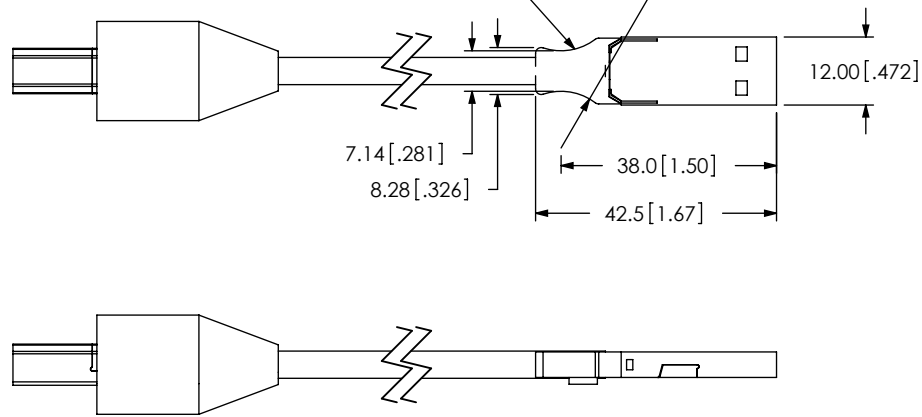

-AM END OPTION  
IN-PROCESS 11  
OVERMOLDING

(SAME AS -AMS AND -BMS END OPTIONS IN-PROCESS 11, UNLESS OTHERWISE STATED)

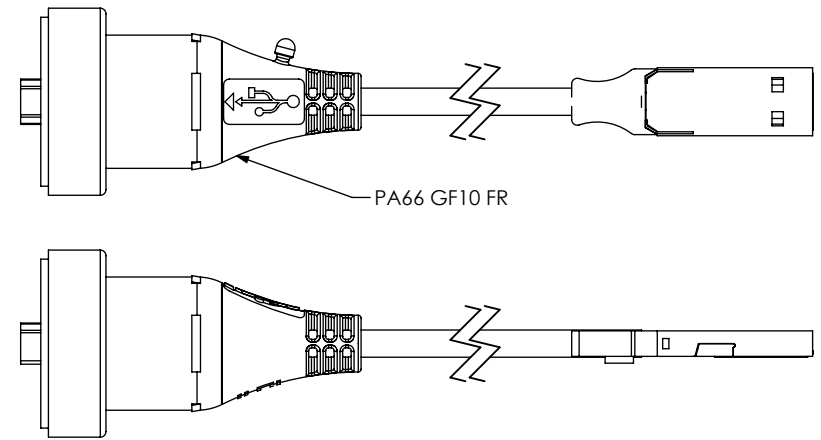

-AM END OPTION  
IN-PROCESS 12  
NON-SEALED OVERMOLDING

(SAME AS -AMS AND -BMS END OPTIONS IN-PROCESS 12, UNLESS OTHERWISE STATED)

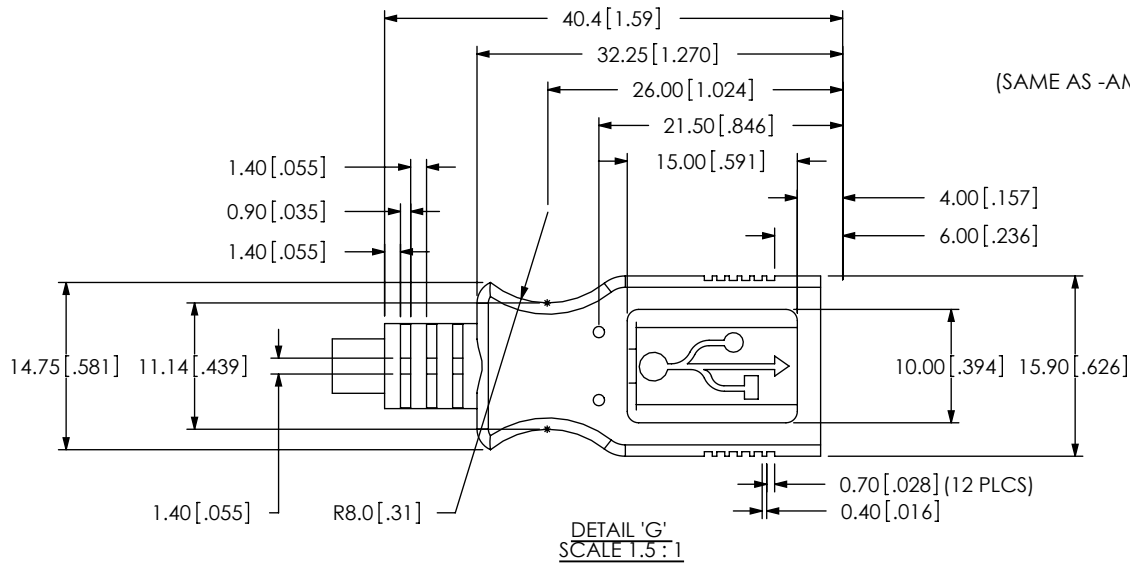
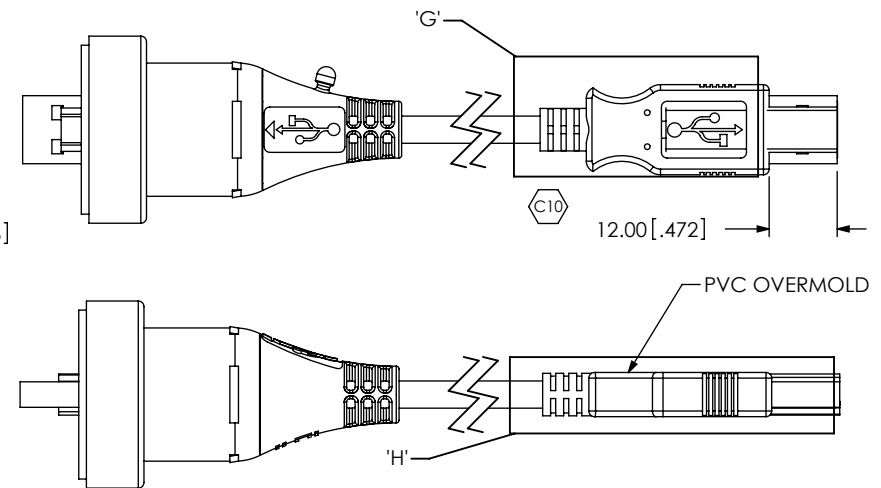

DETAIL 'G'  
SCALE 1.5:1

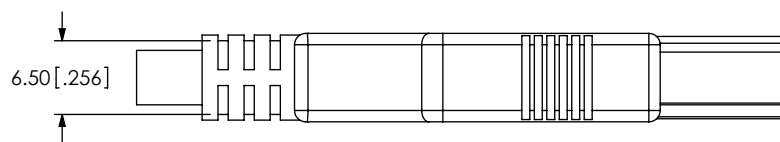

DETAIL 'H'  
SCALE 1.5:1

PROPRIETARY NOTE  
THIS DOCUMENT CONTAINS INFORMATION  
CONFIDENTIAL AND PROPRIETARY TO  
SAMTEC, INC. AND SHALL NOT BE REPRODUCED  
OR TRANSFERRED TO OTHER DOCUMENTS OR  
DISCLOSED TO OTHERS OR USED FOR ANY  
PURPOSE OTHER THAN THAT WHICH IT WAS  
OBTAINED WITHOUT THE EXPRESSED WRITTEN  
CONSENT OF SAMTEC, INC.

DO NOT SCALE DRAWING

SHEET SCALE: 1:1.33333

**samtec**

520 PARK EAST BLVD, NEW ALBANY, IN 47150  
PHONE: 812-944-6733 FAX: 812-948-5047  
e-Mail: info@SAMTEC.com code: 55322

DESCRIPTION:  
SEALED CIRCULAR CABLE PLUG, USB

DWG. NO.  
**SCPU-17-X-X.XX-XXX-XXX**

BY: CHAD F 12/8/2004 SHEET 8 OF 10



**IN-PROCESS 5**  
 TERMINATE TO SUB-USB-A-G-B-01 (SEE NOTE 19)  
 (SAME AS -AMS AND -BMS END OPTIONS IN-PROCESS 5, UNLESS OTHERWISE STATED)

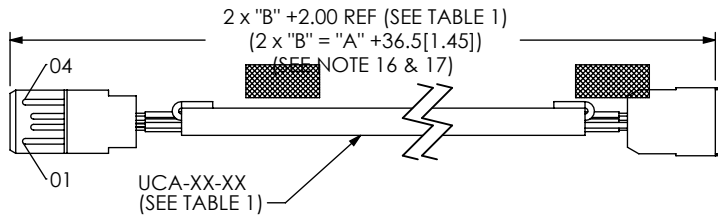
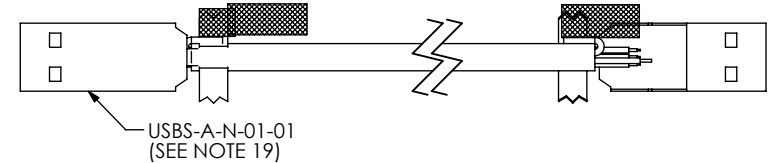
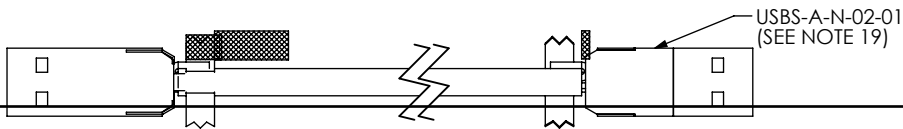

TABLE 4 - PIN-OUT	
POS	WIRE COLOR
01	RED
02	WHITE
03	GREEN
04	BLACK

**IN-PROCESS 6**  
 ADD USBS-A-N-01-01 SHELL  
 (SAME AS -AMS AND -BMS END OPTIONS IN-PROCESS 7, UNLESS OTHERWISE STATED)



**IN-PROCESS 7**  
 ADD USBS-A-N-02-01 SHELL  
 (SAME AS -AMS AND -BMS END OPTIONS IN-PROCESS 8, UNLESS OTHERWISE STATED)



**IN-PROCESS 8**  
 CRIMP SHELLS OVER BRAID  
 (SAME AS -AMS AND -BMS END OPTIONS IN-PROCESS 9, UNLESS OTHERWISE STATED)



**IN-PROCESS 9**  
 PREMOLDING  
 (SAME AS -AMS AND -BMS END OPTIONS IN-PROCESS 10, UNLESS OTHERWISE STATED)

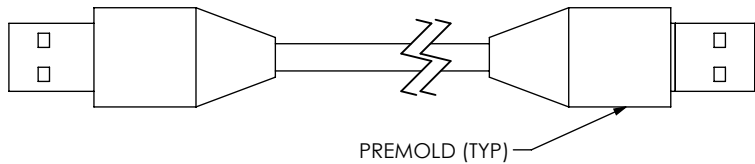

**IN-PROCESS 10**  
 ADD SCN-17-01  
 (SAME AS -AMS AND -BMS END OPTIONS IN-PROCESS 11, UNLESS OTHERWISE STATED)

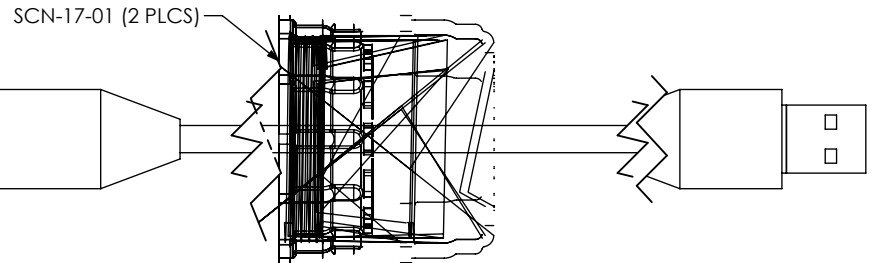

**IN-PROCESS 11**  
 OVERMOLDING  
 (SAME AS -AMS AND -BMS END OPTIONS IN-PROCESS 12, UNLESS OTHERWISE STATED)

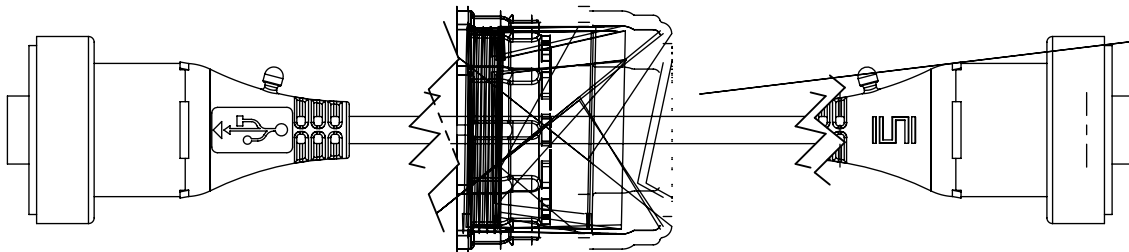

**IN-PROCESS 12**  
 (CUT IN HALF AND TRIM TO LENGTH)

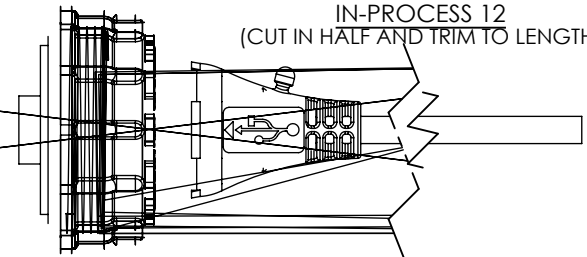

**PROPRIETARY NOTE**  
 THIS DOCUMENT CONTAINS INFORMATION CONFIDENTIAL AND PROPRIETARY TO SAMTEC, INC. AND SHALL NOT BE REPRODUCED OR TRANSFERRED TO OTHER DOCUMENTS OR DISCLOSED TO OTHERS OR USED FOR ANY PURPOSE OTHER THAN THAT WHICH IT WAS OBTAINED WITHOUT THE EXPRESSED WRITTEN CONSENT OF SAMTEC, INC.

DO NOT SCALE DRAWING

SHEET SCALE: 1:1.33333

**samtec**

520 PARK EAST BLVD, NEW ALBANY, IN 47150  
 PHONE: 812-944-6733 FAX: 812-948-5047  
 e-Mail: info@SAMTEC.com code: 55322

DESCRIPTION:  
 SEALED CIRCULAR CABLE PLUG, USB

DWG. NO.  
**SCPU-17-X-X.XX-XXX-XXX**

BY: CHAD F 12/8/2004 SHEET 9 OF 10

**IN-PROCESS 5**  
 TERMINATE TO SUB-USB-B-G-B-01  
 (SAME AS -AMS AND -BMS END OPTIONS IN-PROCESS 6, UNLESS OTHERWISE STATED)

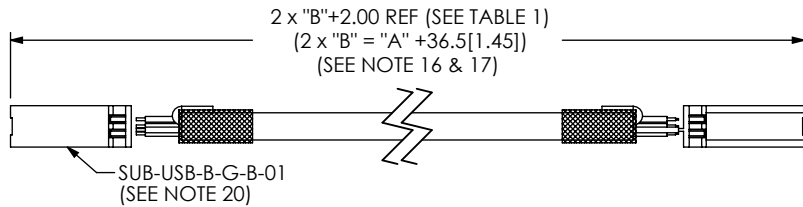

**TABLE 5 - PIN-OUT**

POS	WIRE COLOR
01	RED
02	WHITE
03	GREEN
04	BLACK

**IN-PROCESS 6**  
 ADD USBS-B-N-01-01 SHELL  
 (SAME AS -AMS AND -BMS END OPTIONS IN-PROCESS 7, UNLESS OTHERWISE STATED)

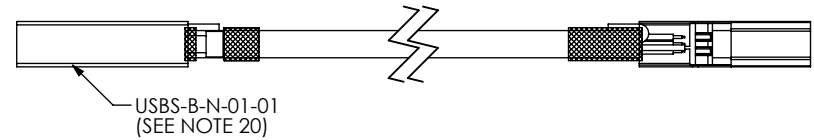

**IN-PROCESS 7**  
 ADD USBS-B-N-02-01 SHELL  
 (SAME AS -AMS AND -BMS END OPTIONS IN-PROCESS 8, UNLESS OTHERWISE STATED)

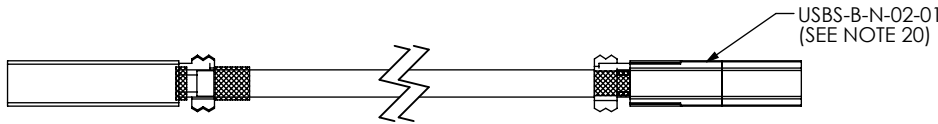

**IN-PROCESS 8**  
 CRIMP SHELLS OVER BRAID  
 (SAME AS -AMS AND -BMS END OPTIONS IN-PROCESS 9, UNLESS OTHERWISE STATED)

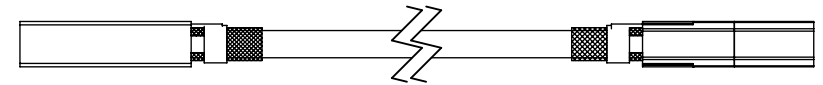

**IN-PROCESS 9**  
 PREMOLDING  
 (SAME AS -AMS AND -BMS END OPTIONS IN-PROCESS 10, UNLESS OTHERWISE STATED)

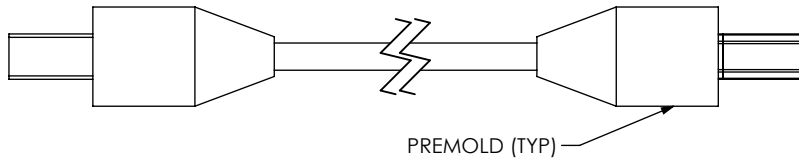

**IN-PROCESS 10**  
 ADD SCN-17-01  
 (SAME AS -AMS AND -BMS END OPTIONS IN-PROCESS 11, UNLESS OTHERWISE STATED)

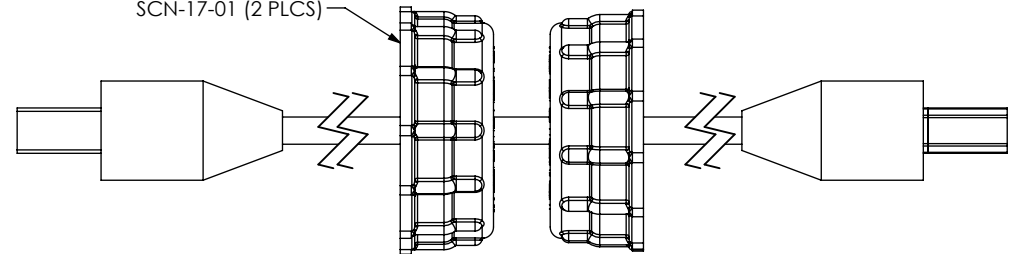

**IN-PROCESS 11**  
 OVERMOLD  
 (SAME AS -AMS AND -BMS END OPTIONS IN-PROCESS 12, UNLESS OTHERWISE STATED)

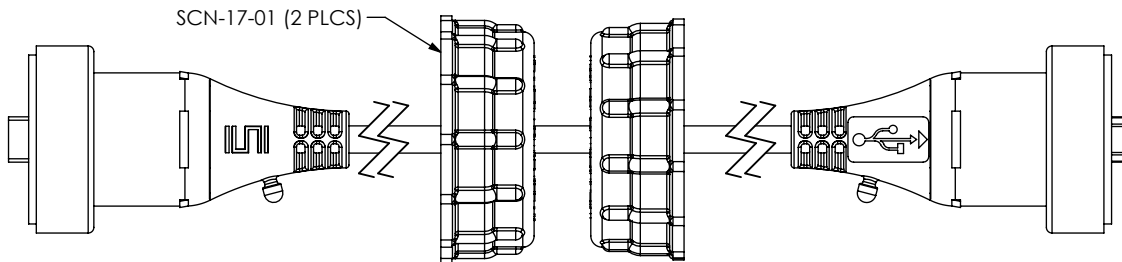

**IN-PROCESS 12**  
 (CUT IN HALF AND TRIM TO LENGTH)

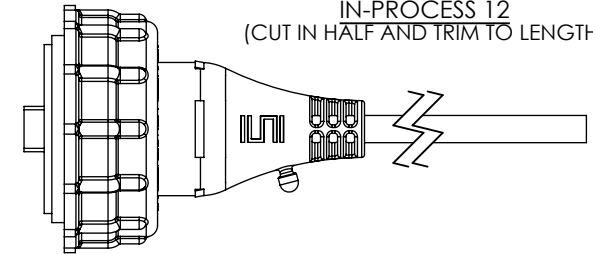

**PROPRIETARY NOTE**  
 THIS DOCUMENT CONTAINS INFORMATION CONFIDENTIAL AND PROPRIETARY TO SAMTEC, INC. AND SHALL NOT BE REPRODUCED OR TRANSFERRED TO OTHER DOCUMENTS OR DISCLOSED TO OTHERS OR USED FOR ANY PURPOSE OTHER THAN THAT WHICH IT WAS OBTAINED WITHOUT THE EXPRESSED WRITTEN CONSENT OF SAMTEC, INC.

DO NOT SCALE DRAWING

SHEET SCALE: 1:1.33333

**samtec**

520 PARK EAST BLVD, NEW ALBANY, IN 47150  
 PHONE: 812-944-6733 FAX: 812-948-5047  
 e-Mail: info@SAMTEC.com code: 55322

DESCRIPTION:  
 SEALED CIRCULAR CABLE PLUG, USB

DWG. NO.  
**SCPU-17-X-X.XX-XXX-XXX**

BY: CHAD F 12/8/2004 SHEET 10 OF 10