

### General Description

The MIC38C4xA are fixed frequency, high performance, current-mode PWM controllers. Micrel's BiCMOS devices are pin compatible with 384x bipolar devices but feature several improvements.

Undervoltage lockout circuitry allows the '42 and '44 versions to start up at 14.5V and operate down to 9V, and the '43 and '45 versions start at 8.4V with operation down to 7.6V. All versions operate up to 20V.

When compared to bipolar 384x devices operating from a 15V supply, start-up current has been reduced to 50 $\mu$ A typical and operating current has been reduced to 4.0mA typical. Decreased output rise and fall times drive larger MOSFETs, and rail-to-rail output capability increases efficiency, especially at lower supply voltages. The MIC38C4xA also features a trimmed oscillator discharge current and bandgap reference.

The MIC38C4xA family is available in 8-pin SOIC and MSOP-8 (MM8) package options

For fast rise and fall times and higher output drive, refer to the MIC38HC4x.

### Features

- Fast 40ns output rise and 30ns output fall times
- $-40^{\circ}\text{C}$  to  $+85^{\circ}\text{C}$  temperature range meets UC284x specifications
- High-performance, low-power BiCMOS Process
- Ultralow start-up current (100 $\mu$ A typical)
- Low operating current (4mA typical)
- CMOS outputs with rail-to-rail swing
- $\geq 500\text{kHz}$  current-mode operation
- Trimmed 5V bandgap reference
- Pin-for-pin compatible with UC3842/3843/3844/3845
- Trimmed oscillator discharge current
- UVLO with hysteresis
- Low cross-conduction currents

### Applications

- Current-mode, off-line, switched-mode power supplies
- Current-mode, dc-to-dc converters.
- Step-down "buck" regulators
- Step-up "boost" regulators
- Flyback, isolated regulators
- Forward converters
- Synchronous FET converters

### Functional Diagram

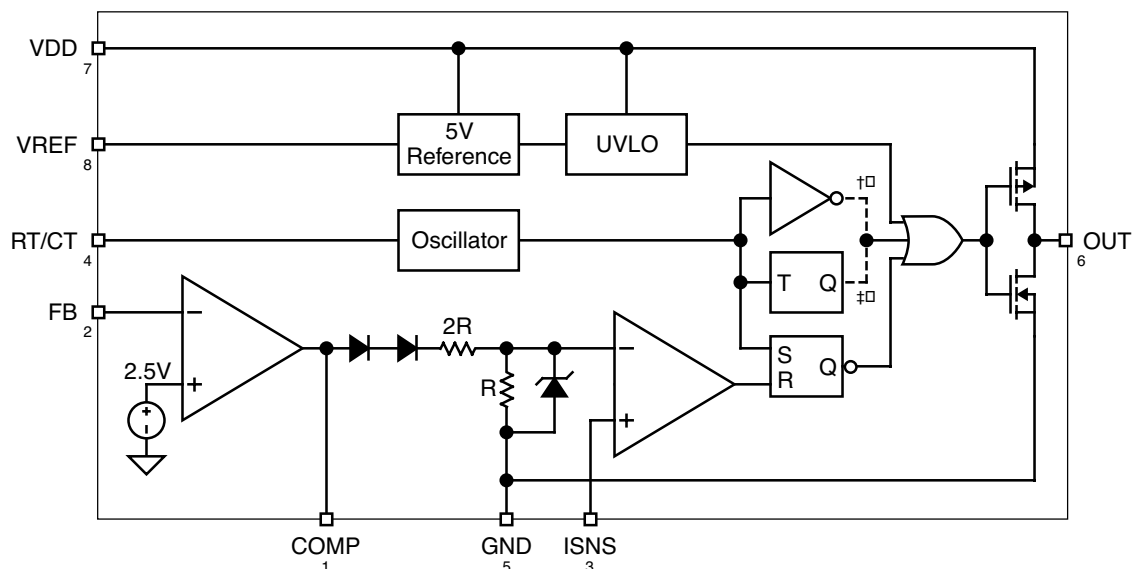

†□MIC38C42A, MIC38C43A (96% max. duty cycle) versions only  
 ‡□MIC38C44A, MIC38C45A (50% max. duty cycle) versions only

## Ordering Information

Part Number		Temperature Range	Package
Standard	Pb-Free		
MIC38C42ABM	MIC38C42AYM	-40°C to +85°C	8-pin SOIC
MIC38C43ABM	MIC38C43AYM	-40°C to +85°C	8-pin SOIC
MIC38C44ABM	MIC38C44AYM	-40°C to +85°C	8-pin SOIC
MIC38C45ABM	MIC38C45AYM	-40°C to +85°C	8-pin SOIC
MIC38C42ABMM	MIC38C42AYMM	-40°C to +85°C	8-pin MM8™
MIC38C43ABMM	MIC38C43AYMM	-40°C to +85°C	8-pin MM8™
MIC38C44ABMM	MIC38C44AYMM	-40°C to +85°C	8-pin MM8™
MIC38C45ABMM	MIC38C45AYMM	-40°C to +85°C	8-pin MM8™

Refer to the Part Number Cross Reference for a listings of Micrel devices equivalent to UC284x and UC384x devices.

## Selection Guide

Duty Cycle	UVLO Thresholds	
	Startup 8.4V Minimum Operating 7.6V	Startup 14.5V Minimum Operating 9V
0% to 96%	MIC38C43A	MIC38C42A
0% to 50%	MIC38C45A	MIC38C44A

## Pin Configuration

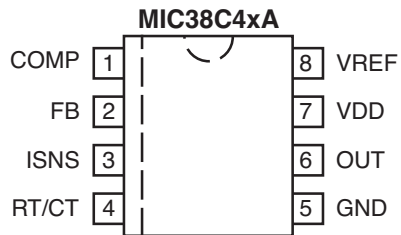

**8-Lead SOIC (M)**  
**8-Lead MM8™ (MM)**

## Pin Description

Pin Number	Pin Name	Pin Function
1	COMP	Compensation: Connect external compensation network to modify the error amplifier output.
2	FB	Feedback (Input): Error amplifier input. Feedback is 2.5V at desired output voltage.
3	ISNS	Current Sense (Input): Current sense comparator input. Connect to current sensing resistor or current transformer.
4	RT/CT	Timing Resistor/Timing Capacitor: Connect external RC network to select switching frequency.
5	GND	Ground: Combined analog and power ground.
6	OUT	Power Output: Totem-pole output.
7	VDD	Analog Supply (Input): Controller circuitry supply input. Return to analog ground (AGND).
8	VREF	5V Reference (Output): Connect external RC network.

**Absolute Maximum Ratings**

Supply Voltage ( $V_{DD}$ )	20V
Switch Supply Voltage ( $V_D$ )	20V
Current Sense Voltage ( $V_{ISNS}$ )	-0.3V to 5.5V
Feedback Voltage ( $V_{FB}$ )	-0.3V to 5.5V
Output Current ( $I_{OUT}$ )	0.5A
Storage Temperature ( $T_A$ )	-65°C to +150°C

**Operating Ratings**

Junction Temperature ( $T_J$ )	150°C
Package Thermal Resistance	
8-Pin MM8™ ( $\theta_{JA}$ )	250°C/W
8-Pin SOIC ( $\theta_{JA}$ )	170°C/W

**Electrical Characteristics**(Note 6)

$V_{DD} = 15V$ , **Note 4**;  $R_T = 11.0k$ ;  $C_T = 3.3nF$ ;  $-40^\circ C \leq T_A \leq 85^\circ C$ ; unless noted

Parameter	Test Conditions	Min	Typ	Max	Units
-----------	-----------------	-----	-----	-----	-------

**Reference Section**

Output Voltage	$T_A = 25^\circ C$ , $I_O = 1mA$	4.90	5.00	5.10	V
Line Regulation	$12V \leq V_{DD} \leq 18V$ , $I_O = 5\mu A$		2	20	mV
Load Regulation	$1 \leq I_O \leq 20mA$		1	25	mV
Temp. Stability	<b>Note 1</b>		0.2		mV/°C
Total Output Variation	Line, Load, Temp., <b>Note 1</b>	4.82		5.18	V
Output Noise Voltage	$10Hz \leq f \leq 10kHz$ , $T_A = 25^\circ C$ , <b>Note 1</b>		50		$\mu V$
Long Term Stability	$T_A = 125^\circ C$ , 1000 hrs., <b>Note 1</b>		5	25	mV
Output Short Circuit		-30	-80	-180	mA

**Oscillator Section**

Initial Accuracy	$T_A = 25^\circ C$ , <b>Note 5</b>	47	53	59	kHz
Voltage Stability	$12 \leq V_{DD} \leq 18V$		0.2	1.0	%
Temp. Stability	$T_{MIN} \leq T_A \leq T_{MAX}$ , <b>Note 1</b>		0.04		%/°C
Clock Ramp Reset Current	$T_A = 25^\circ C$ , $V_{RT/CT} = 2V$ , <b>Note 1</b>	7.7	8.4	9.0	mA
Amplitude	$V_{RT/CT}$ peak to peak		1.9		Vp-p

**Error Amp Section**

Input Voltage	$V_{COMP} = 2.5V$	2.4	2.50	2.58	V
Input Bias Current	$V_{FB} = 5.0V$		-0.1	-2	$\mu A$
$A_{VOL}$	$2 \leq V_O \leq 4V$	65	90		dB
Unity Gain Bandwidth	<b>Note 1</b>	0.7	1.0		MHz
PSRR	$12 \leq V_{DD} \leq 18V$	60			dB
Output Sink Current	$V_{FB} = 2.7V$ , $V_{COMP} = 1.1V$	2	14		mA
Output Source Current	$V_{FB} = 2.3V$ , $V_{COMP} = 5V$	-0.3	-1		mA
$V_{OUT}$ High	$V_{FB} = 2.3V$ , $R_L = 15k$ to ground	5	6.8		V
$V_{OUT}$ Low	$V_{FB} = 2.7V$ , $R_L = 15k$ to $V_{REF}$		0.1	1.1	V

Parameter	Test Conditions	Min	Typ	Max	Units
<b>Current Sense</b>					
Gain	Notes 2, 3	2.85	3.0	3.15	V/V
Maximum Threshold	$V_{COMP} = 5V$ , Note 2	0.9	1	1.1	V
PSRR	$12 \leq V_{DD} \leq 18V$ , Note 2		70		dB
Input Bias Current			-0.1	-2	$\mu A$
Delay to Output			120	250	ns

**Output**

$R_{DS(ON)}$ High	$I_{SOURCE} = 200mA$		20		$\Omega$
$R_{DS(ON)}$ Low	$I_{SINK} = 200mA$		11		$\Omega$
Rise Time	$T_A = 25^\circ C$ , $C_L = 1nF$		40	80	ns
Fall Time	$T_A = 25^\circ C$ , $C_L = 1nF$		30	60	ns

**Undervoltage Lockout**

Start Threshold	MIC38C42A/4A	13.5	14.5	15.5	V
	MIC38C43A/5A	7.8	8.4	9.0	V
Minimum Operating Voltage	MIC38C42A/4A	8	9	10	V
	MIC38C43A/5A	7.0	7.6	8.2	V

**Pulse Width Modulator**

Maximum Duty Cycle	MIC38C42A/3A	94	96		%
	MIC38C44A/5A	46	50		%
Minimum Duty Cycle				0	%

**Total Standby Current**

Start-Up Current	$V_{DD} = 13V$ for MIC38C42A/44A $V_{DD} = 7.5V$ for MIC38C43A/45A		100	230	$\mu A$
Operating Supply Current	$V_{FB} = V_{ISNS} = 0V$		4.0	6.0	mA

**Note 1:** These parameters, although guaranteed, are not 100% tested in production.

**Note 2:** Parameter measured at trip point of latch with  $V_{EA} = 0$ .

**Note 3:** Gain defined as:

$$A = \frac{\Delta V_{PIN1}}{V_{TH}(I_{SNS})}; 0 \leq V_{TH}(I_{SNS}) \leq 0.8V$$

**Note 4:** Adjust  $V_{DD}$  above the start threshold before setting at 15V.

**Note 5:** Output frequency equals oscillator frequency for the MIC38C42 and MIC38C43. Output frequency for the MIC38C44A, and MIC38C45A equals one half the oscillator frequency.

**Note 6:** Specification for packaged product only.

# Typical Characteristics

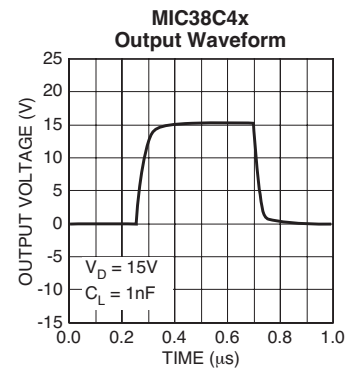
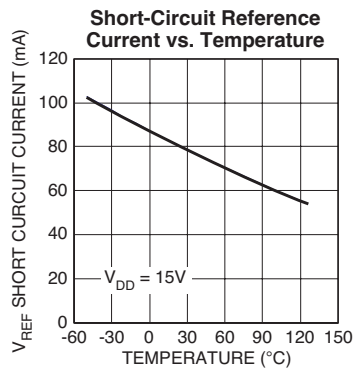
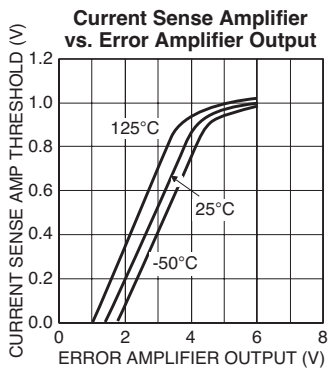
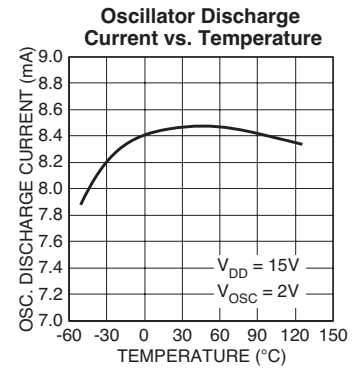
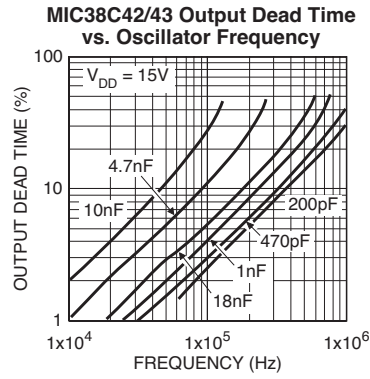
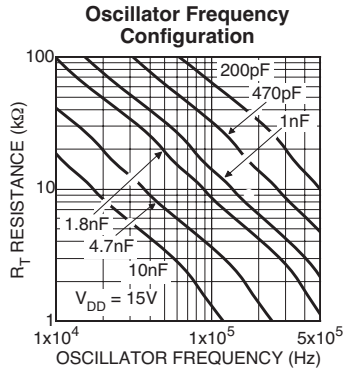

## Application Information

Familiarity with 384x converter designs is assumed.

### MIC38C4x Advantages

#### Start-up Current

Start-up current has been reduced to an ultra-low 50 $\mu$ A (typical) permitting higher-valued, lower-wattage, start-up resistors (powers controller during power supply start-up). The reduced resistor wattage reduces cost and printed circuit space.

#### Operating Current

Operating current has been reduced to 4mA compared to 11mA for a typical bipolar controller. The controller runs cooler and the  $V_{DD}$  hold-up capacitance required during start-up may be reduced.

#### Output Driver

Complementary internal P- and N-channel MOSFETs produce rail-to-rail output voltages for better performance driving external power MOSFETs. The driver transistor's low on-resistance and high peak current capability can drive gate capacitances of greater than 1000pF. The value of output capacitance which can be driven is determined only by the rise/fall time requirements. Within the restrictions of output capacity and controller power dissipation, maximum switching frequency can approach 500kHz.

### Design Precautions

When operating near 20V, circuit transients can easily exceed the 20V absolute maximum rating, permanently damaging the controller's CMOS construction. To reduce transients, use a 0.1 $\mu$ F low-ESR capacitor to next to the controller's supply  $V_{DD}$  (or  $V_D$  for '-1' versions) and ground connections. Film type capacitors, such as Wima MKS2, are recom-

mended.

When designing high-frequency converters, avoid capacitive and inductive coupling of the switching waveform into high-impedance circuitry such as the error amplifier, oscillator, and current sense amplifier. Avoid long printed-circuit traces and component leads. Locate oscillator and compensation circuitry near the IC. Use high frequency decoupling capacitors on  $V_{REF}$ , and if necessary, on  $V_{DD}$ . Return high  $di/dt$  currents directly to their source and use large area ground planes.

### Buck Converter

Refer to figure 1. When at least 26V is applied to the input, C5 is charged through R2 until the voltage  $V_{DD}$  is greater than 14.5V (the undervoltage lockout value of the MIC38C42). Output switching begins when Q1 is turned on by the gate drive transformer T1, charging the output filter capacitor C3 through L1. D5 supplies a regulated +12V to  $V_{DD}$  once the circuit is running.

Current sense transformer CT1 provides current feedback to ISNS for current-mode operation and cycle-by-cycle current limiting. This is more efficient than a high-power sense resistor and provides the required ground-referenced level shift.

When Q1 turns off, current flow continues from ground through D1 and L1 until Q1 is turned on again.

The 100V Schottky diode D1 reduces the forward voltage drop in the main current path, resulting in higher efficiency than could be accomplished using an ultra-fast-recovery diode. R1 and C2 suppress parasitic oscillations from D1.

Using a high-value inductance for L1 and a low-ESR capacitor for C3 permits small capacitance with minimum output ripple. This inductance value also improves circuit efficiency by reducing the flux swing in L1.

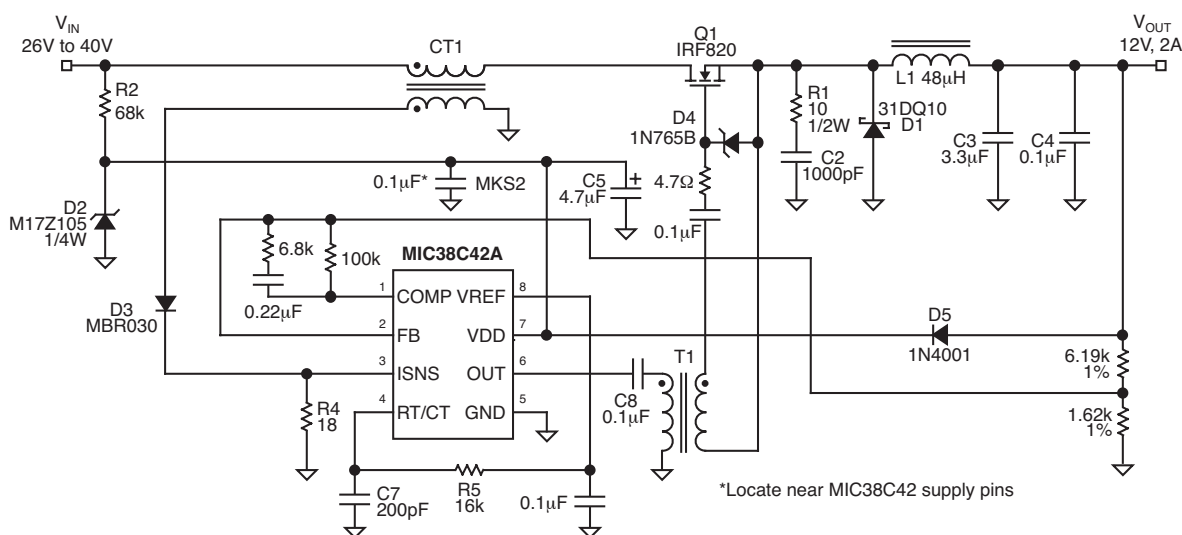
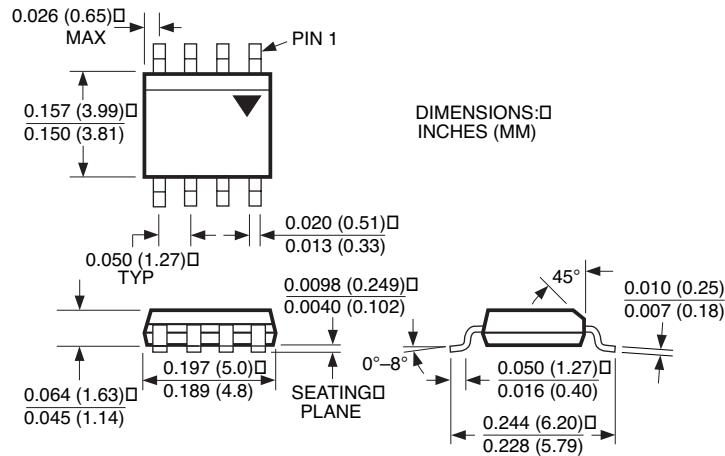

Figure 1. 500kHz, 25W, Buck Converter





Package Information



8-Pin SOP (M)

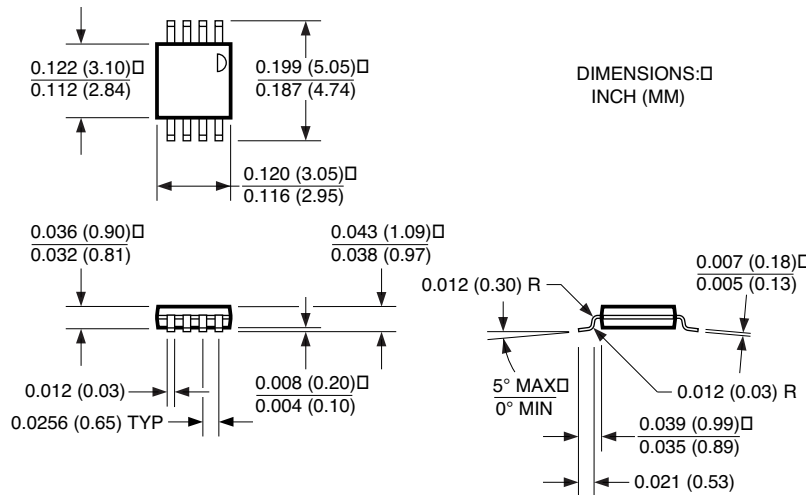

8-Pin MSOP (MM)

MICREL INC. 2180 FORTUNE DRIVE SAN JOSE, CA 95131 USA

TEL + 1 (408) 944-0800 FAX + 1 (408) 474-1000 WEB <http://www.micrel.com>

This information furnished by Micrel in this data sheet is believed to be accurate and reliable. However no responsibility is assumed by Micrel for its use. Micrel reserves the right to change circuitry and specifications at any time without notification to the customer.

Micrel Products are not designed or authorized for use as components in life support appliances, devices or systems where malfunction of a product can reasonably be expected to result in personal injury. Life support devices or systems are devices or systems that (a) are intended for surgical implant into the body or (b) support or sustain life, and whose failure to perform can be reasonably expected to result in a significant injury to the user. A Purchaser's use or sale of Micrel Products for use in life support appliances, devices or systems is a Purchaser's own risk and Purchaser agrees to fully indemnify Micrel for any damages resulting from such use or sale.

© 2002 Micrel Incorporated