

TrueTouch® Single-Touch Touchscreen Controller

Features

- TrueTouch® capacitive touchscreen controller
 - True single-layer ITO sensor support – no bridges
 - Lowers touchscreen system cost
 - Single finger position reported
 - X, Y positions and Z magnitude reported
 - Screen sizes up to 3.6-inch diagonal
 - Up to 32 sense pins
 - Fat finger detection and tracking
 - Large object detection
 - Self-calibrating to environmental changes
 - Resistant to display noise
 - Robust operation in noisy RF environment
 - 1.71-V to 5.5-V input supply range
 - Single supply voltage
 - Compatible with 1.8-V I²C signaling
 - Integrated voltage regulators – no need for dedicated voltage regulators
- Performance
 - Noise-free resolution: 0.1 mm
 - Accuracy with 1 finger on the touchscreen: 0.8 mm
 - >110-Hz refresh rate with one finger on the touchscreen
 - Best-in-class active power of 3.6 mW
 - Best-in-class Low-Power state current: 0.7 mA
 - Best-in-class Deep-Sleep state current: 100 nA
- Extended feature set
 - Water rejection – no false touches
 - Capacitive buttons supported
 - On-chip gesture detection
 - Single-click, double-click
 - One-finger pan gestures
 - Two-finger pinch/zoom gestures [1]
- Sensor and system design
 - Supports chip-on-flex and chip-on-board
 - Supports plastic film and glass single-layer touch sensors
 - Supports a variety of touchscreen sensor stackups
- Communication interface
 - I²C slave up to 400 kbps
 - SPI slave with 2 Mbps sustained data throughput
 - Field upgrades through integrated bootloader
- Host development kit (HDK)
 - Android driver support
 - Supports custom driver development
 - TrueTouch host emulator – acts as host for early prototyping
- Package options
 - 32-pin 5 × 5 × 0.55-mm QFN
 - 48-pin 7 × 7 × 1.0-mm QFN
 - 30-ball 2.2 × 2.32 × 0.4-mm WLCSP

CY8CTST241/CY8CTST242 Block Diagram

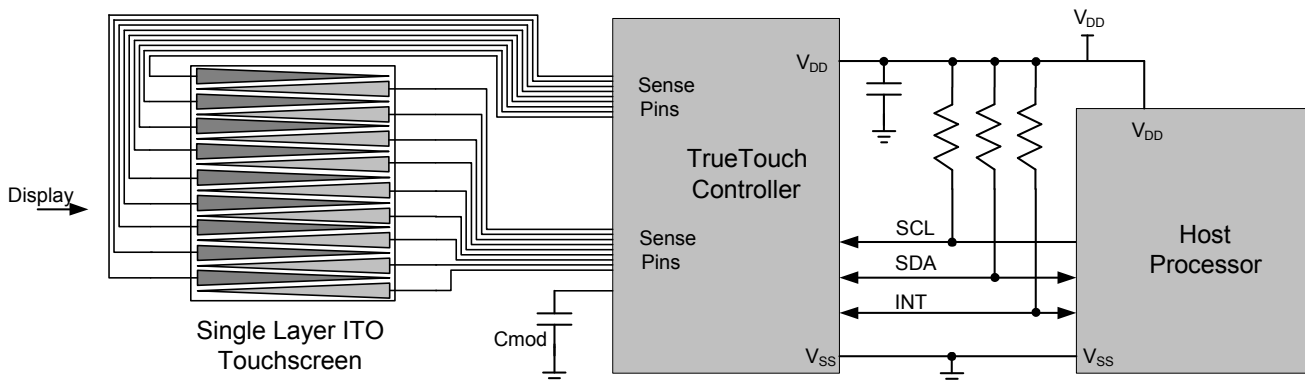

Note

1. Pinch/zoom gestures are only supported on CY8CTST242.

Ordering Information

The following table lists the TrueTouch Standard Product Single Touch Touchscreen Controllers. For information on other TrueTouch families, visit <http://www.cypress.com/truetouch>.

Table 1. Device Ordering Information

Part Number	TrueTouch						Sensor		Minimum Interface Voltage	Supply Voltage Operating Range	Bootloader	I ² C	SPI	UART	Package
	Typical Screen Size (in.) (4:3 Aspect Ratio)	Maximum Nodes	Maximum Fingers	On-chip Gesture Decoding	True Single Layer Sensor	Large Object Detection	Glass	Film							
CY8CTST241-LQI-01(T)	3.3 ^[2]	24	1	✓	✓	✓	✓	✓	1.8	1.71-5.5	✓	✓	✓	✓	32-pin QFN
CY8CTST241-LTI-01(T)	3.6 ^[2]	32	1	✓	✓	✓	✓	✓	1.8	1.71-5.5	✓	✓	✓	✓	48-pin QFN
CP8CTST241-FNC-01(T)	3.6 ^[2]	24	1	✓	✓	✓	✓	✓	1.8	1.71-5.5	✓	✓	✓	✓	30-ball WLCSP
CY8CTST242-LQI-01(T)	3.6 ^[2]	24	2	✓	✓	✓	✓	✓	1.8	1.71-5.5	✓	✓	✓	✓	32-pin QFN
CY8CTST242-LTI-01(T)	3.6 ^[2]	32	2	✓	✓	✓	✓	✓	1.8	1.71-5.5	✓	✓	✓	✓	48-pin QFN
CP8CTST242-FNC-01T	3.6 ^[2]	24	2	✓	✓	✓	✓	✓	1.8	1.71-5.5	✓	✓	✓	✓	30-ball WLCSP

Ordering Code Definitions

Cx8 C TST 24x - xxx xx(T)

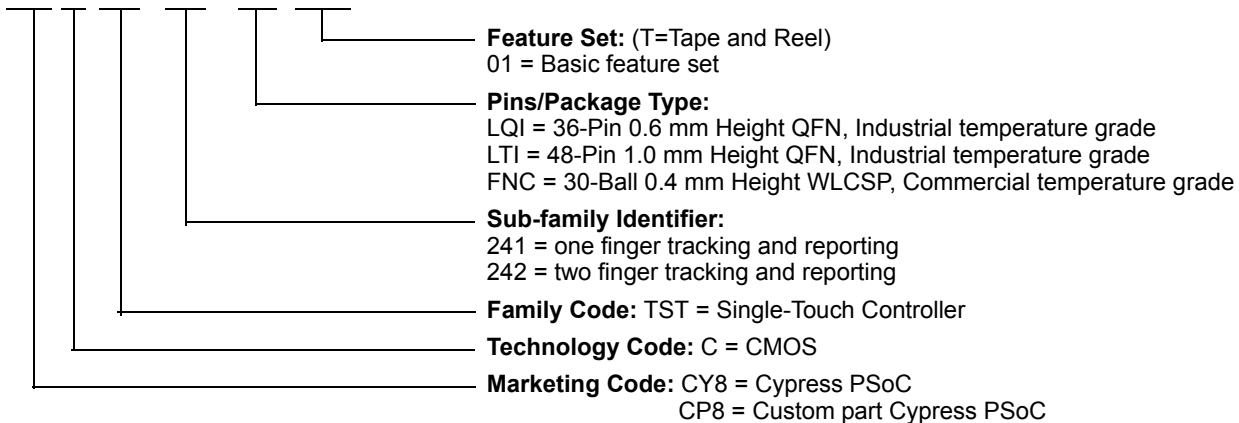

Note

2. A screen size of 3.6-inches is met using 6.1-mm pitch for 24-nodes devices and a 4.1-mm pitch for 32-node devices.

Document History Page

Document Title: CY8CTST241/CY8CTST242, TrueTouch® Single-Touch Touchscreen Controller Document Number: 001-91041				
Rev.	ECN No.	Orig. of Change	Submission Date	Description of Change
**	4278978	SWU	02/12/2014	New summary data sheet.
*A	5378716	ELG	08/06/2016	Added CY8CTST241 part related information in all instances across the document. Added CY8CTST241/CY8CTST242 Block Diagram . Updated Ordering Information : Updated part numbers. Updated Ordering Code Definitions . Updated to new template.

Sales, Solutions, and Legal Information

Worldwide Sales and Design Support

Cypress maintains a worldwide network of offices, solution centers, manufacturer's representatives, and distributors. To find the office closest to you, visit us at [Cypress Locations](#).

Products

ARM® Cortex® Microcontrollers	cypress.com/arm
Automotive	cypress.com/automotive
Clocks & Buffers	cypress.com/clocks
Interface	cypress.com/interface
Lighting & Power Control	cypress.com/powerpsoc
Memory	cypress.com/memory
PSoC	cypress.com/psoc
Touch Sensing	cypress.com/touch
USB Controllers	cypress.com/usb
Wireless/RF	cypress.com/wireless

PSoC® Solutions

[PSoC 1](#) | [PSoC 3](#) | [PSoC 4](#) | [PSoC 5LP](#)

Cypress Developer Community

[Forums](#) | [Projects](#) | [Video](#) | [Blogs](#) | [Training](#) | [Components](#)

Technical Support

cypress.com/support

© Cypress Semiconductor Corporation, 2014–2016. This document is the property of Cypress Semiconductor Corporation and its subsidiaries, including Spansion LLC ("Cypress"). This document, including any software or firmware included or referenced in this document ("Software"), is owned by Cypress under the intellectual property laws and treaties of the United States and other countries worldwide. Cypress reserves all rights under such laws and treaties and does not, except as specifically stated in this paragraph, grant any license under its patents, copyrights, trademarks, or other intellectual property rights. If the Software is not accompanied by a license agreement and you do not otherwise have a written agreement with Cypress governing the use of the Software, then Cypress hereby grants you a personal, non-exclusive, nontransferable license (without the right to sublicense) (1) under its copyright rights in the Software (a) for Software provided in source code form, to modify and reproduce the Software solely for use with Cypress hardware products, only internally within your organization, and (b) to distribute the Software in binary code form externally to end users (either directly or indirectly through resellers and distributors), solely for use on Cypress hardware product units, and (2) under those claims of Cypress's patents that are infringed by the Software (as provided by Cypress, unmodified) to make, use, distribute, and import the Software solely for use with Cypress hardware products. Any other use, reproduction, modification, translation, or compilation of the Software is prohibited.

TO THE EXTENT PERMITTED BY APPLICABLE LAW, CYPRESS MAKES NO WARRANTY OF ANY KIND, EXPRESS OR IMPLIED, WITH REGARD TO THIS DOCUMENT OR ANY SOFTWARE OR ACCOMPANYING HARDWARE, INCLUDING, BUT NOT LIMITED TO, THE IMPLIED WARRANTIES OF MERCHANTABILITY AND FITNESS FOR A PARTICULAR PURPOSE. To the extent permitted by applicable law, Cypress reserves the right to make changes to this document without further notice. Cypress does not assume any liability arising out of the application or use of any product or circuit described in this document. Any information provided in this document, including any sample design information or programming code, is provided only for reference purposes. It is the responsibility of the user of this document to properly design, program, and test the functionality and safety of any application made of this information and any resulting product. Cypress products are not designed, intended, or authorized for use as critical components in systems designed or intended for the operation of weapons, weapons systems, nuclear installations, life-support devices or systems, other medical devices or systems (including resuscitation equipment and surgical implants), pollution control or hazardous substances management, or other uses where the failure of the device or system could cause personal injury, death, or property damage ("Unintended Uses"). A critical component is any component of a device or system whose failure to perform can be reasonably expected to cause the failure of the device or system, or to affect its safety or effectiveness. Cypress is not liable, in whole or in part, and you shall and hereby do release Cypress from any claim, damage, or other liability arising from or related to all Unintended Uses of Cypress products. You shall indemnify and hold Cypress harmless from and against all claims, costs, damages, and other liabilities, including claims for personal injury or death, arising from or related to any Unintended Uses of Cypress products.

Cypress, the Cypress logo, Spansion, the Spansion logo, and combinations thereof, PSoC, CapSense, EZ-USB, F-RAM, and Traveo are trademarks or registered trademarks of Cypress in the United States and other countries. For a more complete list of Cypress trademarks, visit cypress.com. Other names and brands may be claimed as property of their respective owners.