2CH PWM DC/DC CONTROLLER

NO.EA-086-160125

OUTLINE

The R1280D002x Series are CMOS-based 2-channel PWM Step-up (as Channel 1)/Inverting (as Channel 2) DC/DC converter controllers.

Each of the R1280D002x Series consists of an oscillator, a PWM control circuit, a reference voltage unit, an error amplifier, a reference current unit, a protection circuit, and an under voltage lockout (UVLO) circuit. A high efficiency Step-up/Inverting DC/DC converter can be composed of this IC with inductors, diodes, power MOSFETs, resistors, and capacitors. Each Output Voltage can be adjustable with external resistors, while soft-start time can be adjustable with external capacitors.

Maximum Duty Cycle of R1280D002A and C series can be also adjustable with external resistors.

Maximum Duty Cycle of R1280D002B is built-in as 90%(Typ.).

When CE pin of R1280D002B is set at GND level, this IC turns off external power MOSFETs of Step-up/Inverting as Standby-mode.

Standby current is typically 0 μ A.

As for a protection circuit, if Maximum duty cycle of either Step-up DC/DC converter side or Inverting DC/DC converter side is continued for a certain time, the R1280D Series latch both external drivers with their off state by its Latch-type protection circuit. Delay time for protection is internally fixed typically at 100ms. To release the protection circuit, restart with power-on (Voltage supplier is equal or less than UVLO detector threshold level), or as for R1280D002B, once after making the circuit be stand-by with chip enable pin and enable the circuit again.

FEATURES

- Input Voltage Range2.5V to 5.5V
- Built-in Latch-type Protection Function by monitoring duty cycle (Fixed Delay Time Typ. 100ms)
- Oscillator Frequency700kHz (R1280D002A,B)/200kHz (R1280D002C)
- Maximum Duty CycleTyp. 90% (Only applied to R1280D002B Series)
- High Reference Voltage Accuracy $\pm 1.5\%$
- U.V.L.O. Threshold.....Typ. 2.2V (Hysteresis: Typ. 0.1V)
- Small Packagethin SON-10 (package thickness Max. 0.9mm)

APPLICATIONS

- Constant Voltage Power Source for Portable Equipment.
- Constant Voltage Power Source for LCD and CCD.

BLOCK DIAGRAM

- R1280D002A/C

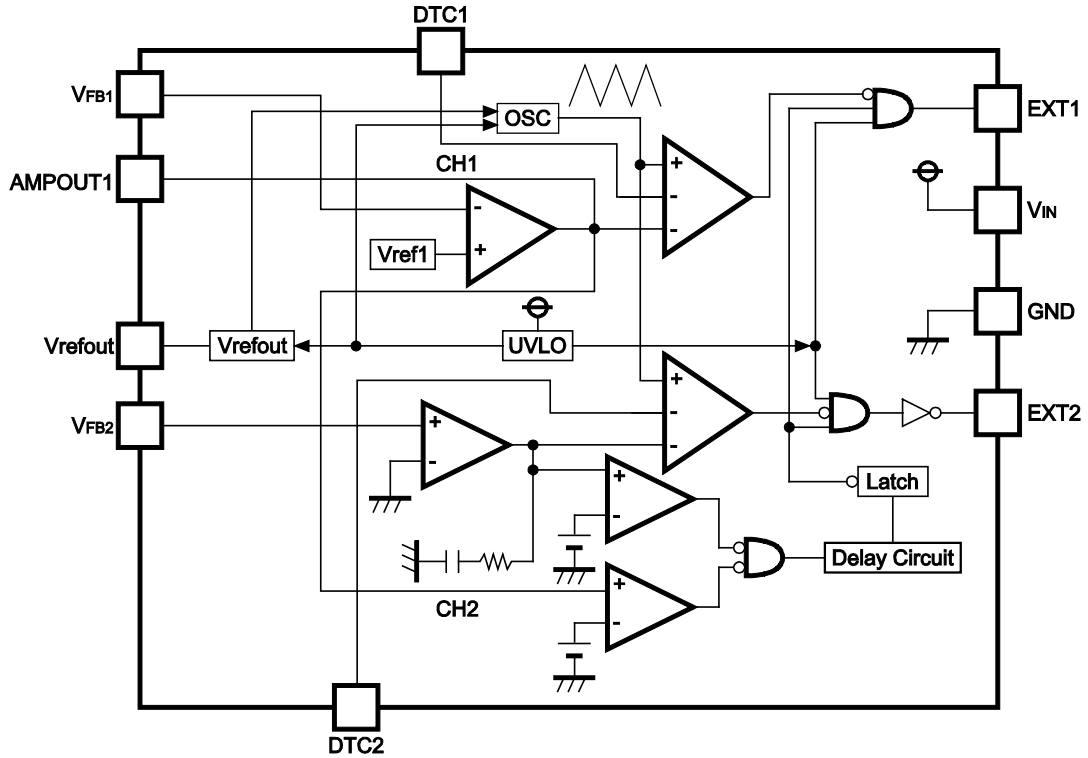

- R1280D002B

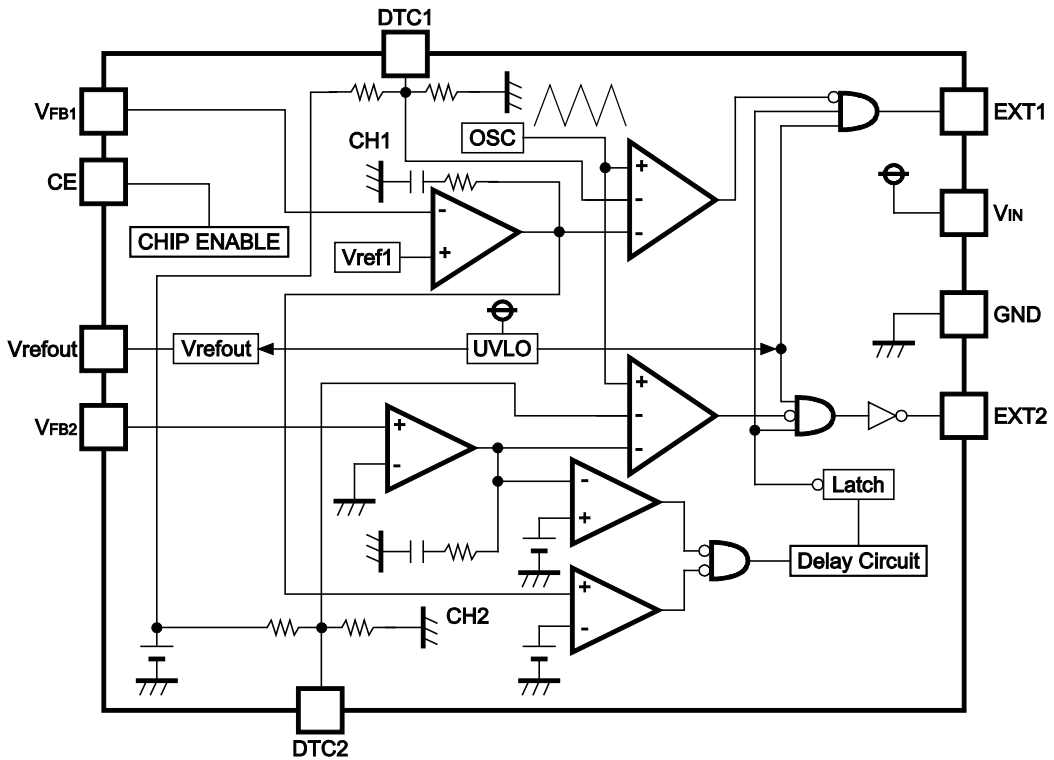

SELECTION GUIDE

The mask option for the ICs can be selected at the user's request. The selection can be made with designating the part number as shown below;

Selection Guide

Product Name	Package	Quantity per Reel	Pb Free	Halogen Free
R1280D002x-TR-FE	SON-10	3,000 pcs	Yes	Yes

x: Designation of Mask Option

A version: fosc=700kHz, with External Phase Compensation for Channel 1

B version: fosc=700kHz, with Internal Phase Compensation and standby mode

C version: fosc=200kHz, with External Phase Compensation for Channel 1

PIN CONFIGURATION

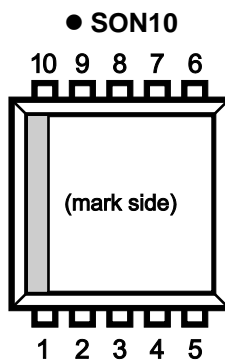

PIN DESCRIPTION

• R1280D002A/C

Pin No	Symbol	Description
1	EXT1	External Transistor of Channel 1 Drive Pin (CMOS Output)
2	GND	Ground Pin
3	AMPOUT1	Amplifier Output Pin of Channel 1
4	DTC1	Maximum Duty Cycle of Channel 1 Setting Pin
5	V _{FB1}	Feedback pin of Channel 1
6	V _{FB2}	Feedback pin of Channel 2
7	DTC2	Maximum Duty Cycle of Channel 2 Setting Pin
8	Vrefout	Reference Output Pin
9	V _{IN}	Voltage Supply Pin of the IC
10	EXT2	External Transistor of Channel 2 Drive Pin (CMOS Output)

• R1280D002B

Pin No	Symbol	Description
1	EXT1	External Transistor of Channel 1 Drive Pin (CMOS Output)
2	GND	Ground Pin
3	CE	Chip Enable Pin
4	DTC1	Soft-start Time of Channel 1 Setting Pin
5	V _{FB1}	Feedback pin of Channel 1
6	V _{FB2}	Feedback pin of Channel 2
7	DTC2	Soft-start Time of Channel 2 Setting Pin
8	Vrefout	Reference Output Pin
9	V _{IN}	Voltage Supply Pin of the IC
10	EXT2	External Transistor of Channel 2 Drive Pin (CMOS Output)

ABSOLUTE MAXIMUM RATINGS

• R1280D002A/C

Symbol	Item	Rating	Unit
V_{IN}	V_{IN} Pin Voltage	6.5	V
$V_{EXT1,2}$	$V_{EXT1,2}$ Pin Output Voltage	$-0.3 \sim V_{IN} + 0.3$	V
$V_{AMPOUT1}$	AMPOUT1 Pin Voltage	$-0.3 \sim V_{IN} + 0.3$	V
$V_{DTC1,2}$	DTC1,2 Pin Voltage	$-0.3 \sim V_{IN} + 0.3$	V
V_{refout}	V_{REFOUT} Pin Voltage	$-0.3 \sim V_{IN} + 0.3$	V
$V_{FB1,2}$	V_{FB1}, V_{FB2} Pin Voltage	$-0.3 \sim V_{IN} + 0.3$	V
$I_{EXT1,2}$	EXT1,2 Pin Output Current	± 50	mA
P_D	Power Dissipation	250	mW
T_{opt}	Operating Temperature Range	-40 to $+85$	$^{\circ}\text{C}$
T_{stg}	Storage Temperature Range	-55 to $+125$	$^{\circ}\text{C}$

• R1280D002B

Symbol	Item	Rating	Unit
V_{IN}	V_{IN} Pin Voltage	6.5	V
$V_{EXT1,2}$	$V_{EXT1,2}$ Pin Output Voltage	$-0.3 \sim V_{IN} + 0.3$	V
V_{CE}	CE Pin Voltage	$-0.3 \sim V_{IN} + 0.3$	V
$V_{DTC1,2}$	DTC1,2 Pin Voltage	$-0.3 \sim V_{IN} + 0.3$	V
V_{refout}	V_{REFOUT} Pin Voltage	$-0.3 \sim V_{IN} + 0.3$	V
$V_{FB1,2}$	V_{FB1}, V_{FB2} Pin Voltage	$-0.3 \sim V_{IN} + 0.3$	V
$I_{EXT1,2}$	EXT1,2 Pin Output Current	± 50	mA
P_D	Power Dissipation	250	mW
T_{opt}	Operating Temperature Range	-40 to $+85$	$^{\circ}\text{C}$
T_{stg}	Storage Temperature Range	-55 to $+125$	$^{\circ}\text{C}$

ELECTRICAL CHARACTERISTICS

• R1280D002A

Topt=25°C

Symbol	Item	Conditions	Min.	Typ.	Max.	Unit
V _{IN}	Operating Input Voltage		2.5		5.5	V
V _{REFOUT}	V _{REFOUT} Voltage Tolerance	V _{IN} =3.3V, I _{OUT} =1mA	1.478	1.500	1.522	V
I _{ROUT}	V _{REFOUT} Output Current	V _{IN} =3.3V	20			mA
$\frac{\Delta V_{REFOUT}}{\Delta V_{IN}}$	V _{REFOUT} Line Regulation	2.5V ≤ V _{IN} ≤ 5.5V		2	6	mV
$\frac{\Delta V_{REFOUT}}{\Delta I_{OUT}}$	V _{REFOUT} Load Regulation	1mA ≤ I _{ROUT} ≤ 10mA V _{IN} =3.3V		6	12	mV
I _{LIM}	V _{REFOUT} Short Current Limit	V _{IN} =3.3V, V _{REFOUT} =0V		25		mA
$\frac{\Delta V_{REFOUT}}{\Delta T}$	V _{REFOUT} Voltage Temperature Coefficient	-40°C ≤ Topt ≤ 85°C		±150		ppm/°C
V _{FBI}	V _{FBI} Voltage	V _{IN} =3.3V	0.985	1.000	1.015	V
$\frac{\Delta V_{FBI}}{\Delta T}$	V _{FBI} Voltage Temperature Coefficient	-40°C ≤ Topt ≤ 85°C		±150		ppm/°C
I _{FBI,2}	I _{FBI,2} Input Current	V _{IN} =5.5V, V _{FBI} or V _{FBI2} =0V or 5.5V	-0.1		0.1	μA
f _{OSC}	Oscillator Frequency	EXT1,2 Pins at no load, V _{IN} =3.3V	595	700	805	kHz
I _{DD1}	Supply Current	V _{IN} =5.5V, EXT1,2 pins at no load		1.4	3.0	mA
R _{EXTH1}	EXT1 "H" ON Resistance	V _{IN} =3.3V, I _{EXT} =-20mA		4.0	8.0	Ω
R _{EXTL1}	EXT1 "L" ON Resistance	V _{IN} =3.3V, I _{EXT} =20mA		2.7	5.0	Ω
R _{EXTH2}	EXT2 "H" ON Resistance	V _{IN} =3.3V, I _{EXT} =-20mA		4.0	8.0	Ω
R _{EXTL2}	EXT2 "L" ON Resistance	V _{IN} =3.3V, I _{EXT} =20mA		3.7	8.0	Ω
T _{DLY}	Delay Time for Protection	V _{IN} =3.3V, V _{FBI} =1.1V→0V	60	100	140	ms
V _{UVLOD}	UVLO Detector Threshold		2.10	2.20	2.35	V
V _{UVLO}	UVLO Released Voltage			V _{UVLOD} +0.10	2.45	V
V _{DTC10}	CH1 Duty=0%	V _{IN} =3.3V	0.1	0.2	0.3	V
V _{DTC1100}	CH1 Duty=100%	V _{IN} =3.3V	1.1	1.2	1.3	V
V _{DTC20}	CH2 Duty=0%	V _{IN} =3.3V	0.1	0.2	0.3	V
V _{DTC2100}	CH2 Duty=100%	V _{IN} =3.3V	1.1	1.2	1.3	V
A _{V1}	CH1 Open Loop Gain	V _{IN} =3.3V		110		dB
F _{T1}	CH1 Single Gain Frequency Band	V _{IN} =3.3V, A _{V1} =0dB		1.9		MHz
V _{ICR1}	CH1 Input Voltage Rang	V _{IN} =3.3V		0.7 to V _{IN}		V
I _{AMPL}	CH1 Sink Current	V _{IN} =3.3V, V _{AMPOUT1} =1.0V, V _{FBI} =V _{FBI} + 0.1V	70	115		μA
I _{AMPH}	CH1 Source Current	V _{IN} =3.3V, V _{AMPOUT1} =1.0V, V _{FBI} =V _{FBI} - 0.1V		-1.4	-0.7	mA
A _{V2}	CH2 Open Loop Gain	V _{IN} =3.3V		60		dB
F _{T2}	CH2 Single Gain Frequency Band	V _{IN} =3.3V, A _{V2} =0dB		3		MHz
V _{ICR2}	CH2 Input Voltage Range	V _{IN} =3.3V		-0.2 to V _{IN} -1.3		V
V _{FBI2}	CH2 Input Offset Voltage	V _{IN} =3.3V	-12		12	mV

● R1280D002B

T_{opt}=25°C

Symbol	Item	Conditions	Min.	Typ.	Max.	Unit
V _{IN}	Operating Input Voltage		2.5		5.5	V
V _{REFOUT}	V _{REFOUT} Voltage Tolerance	V _{IN} =3.3V, I _{OUT} =1mA	1.478	1.500	1.522	V
I _{ROUT}	V _{REFOUT} Output Current	V _{IN} =3.3V	20			mA
$\frac{\Delta V_{REFOUT}}{\Delta V_{IN}}$	V _{REFOUT} Line Regulation	2.5V ≤ V _{IN} ≤ 5.5V		2	6	mV
$\frac{\Delta V_{REFOUT}}{\Delta I_{OUT}}$	V _{REFOUT} Load Regulation	1mA ≤ I _{ROUT} ≤ 10mA V _{IN} =3.3V		6	12	mV
I _{LIM}	V _{REFOUT} Short Current Limit	V _{IN} =3.3V, V _{REFOUT} =0V		25		mA
$\frac{\Delta V_{REFOUT}}{\Delta T}$	V _{REFOUT} Voltage Temperature Coefficient	-40°C ≤ T _{opt} ≤ 85°C		±150		ppm/°C
V _{FB1}	V _{FB1} Voltage	V _{IN} =3.3V	0.985	1.000	1.015	V
$\frac{\Delta V_{FB1}}{\Delta T}$	V _{FB1} Voltage Temperature Coefficient	-40°C ≤ T _{opt} ≤ 85°C		±150		ppm/°C
I _{FB1,2}	I _{FB1,2} Input Current	V _{IN} =5.5V, V _{FB1} or V _{FB2} =0V or 5.5V	-0.1		0.1	μA
f _{OSC}	Oscillator Frequency	EXT1,2 Pins at no load, V _{IN} =3.3V	595	700	805	kHz
I _{DD1}	Supply Current	V _{IN} =5.5V, EXT1,2 pins at no load		1.4	3.0	mA
Maxdty	Maximum Duty Cycle	V _{IN} =3.3V, C _{DTC1,2} =1000pF	84	90	95	%
R _{EXTH1}	EXT1 "H" ON Resistance	V _{IN} =3.3V, I _{EXT} =-20mA		4.0	8.0	Ω
R _{EXTL1}	EXT1 "L" ON Resistance	V _{IN} =3.3V, I _{EXT} =20mA		2.7	5.0	Ω
R _{EXTH2}	EXT2 "H" ON Resistance	V _{IN} =3.3V, I _{EXT} =-20mA		4.0	8.0	Ω
R _{EXTL2}	EXT2 "L" ON Resistance	V _{IN} =3.3V, I _{EXT} =20mA		3.7	8.0	Ω
T _{DLY}	Delay Time for Protection	V _{IN} =3.3V, V _{FB1} =1.1V→0V	60	100	140	ms
T _{SS1}	Soft Start Time1 for Ch1	V _{IN} =3.3V, C _{DTC1} =0.33μF		10		ms
T _{SS2}	Soft Start Time2 for Ch2	V _{IN} =3.3V, C _{DTC2} =0.33μF		15		ms
V _{CEH}	CE "H" Input Voltage	V _{IN} =5.5V	1.5			V
V _{CEL}	CE "L" Input Voltage	V _{IN} =2.5V			0.3	V
V _{UVLOD}	UVLO Detector Threshold		2.10	2.20	2.35	V
V _{UVLO}	UVLO Released Voltage			V _{UVLOD} +0.10	2.45	V
I _{CEH}	CE "H" Input Current	V _{IN} =V _{CE} =5.5V	-0.1		0.1	μA
I _{CEL}	CE "L" Input Current	V _{IN} =5.5V, V _{CE} =0.0V	-0.1		0.1	μA
I _{STB}	Standby Current	V _{IN} =5.5V, V _{CE} =0.0V		0	2	μA
V _{OFF2}	Input Offset Voltage of Ch2.	V _{IN} =3.3V	-12		12	mV

R1280D002x

• R1280D002C

Topt=25°C

Symbol	Item	Conditions	Min.	Typ.	Max.	Unit
V _{IN}	Operating Input Voltage		2.5		5.5	V
V _{REFOUT}	V _{REFOUT} Voltage Tolerance	V _{IN} =3.3V, I _{OUT} =1mA	1.478	1.500	1.522	V
I _{ROUT}	V _{REFOUT} Output Current	V _{IN} =3.3V	20			mA
ΔV _{REFOUT} /ΔV _{IN}	V _{REFOUT} Line Regulation	2.5V ≤ V _{IN} ≤ 5.5V		2	6	mV
ΔV _{REFOUT} /ΔI _{OUT}	V _{REFOUT} Load Regulation	1mA ≤ I _{ROUT} ≤ 10mA V _{IN} =3.3V		6	12	mV
I _{LIM}	V _{REFOUT} Short Current Limit	V _{IN} =3.3V, V _{REFOUT} =0V		25		mA
ΔV _{REFOUT} /ΔT	V _{REFOUT} Voltage Temperature Coefficient	-40°C ≤ Topt ≤ 85°C		±150		ppm/°C
V _{FB1}	V _{FB1} Voltage	V _{IN} =3.3V	0.985	1.000	1.015	V
ΔV _{FB1} /ΔT	V _{FB1} Voltage Temperature Coefficient	-40°C ≤ Topt ≤ 85°C		±150		ppm/°C
I _{FB1,2}	I _{FB1,2} Input Current	V _{IN} =5.5V, V _{FB1} or V _{FB2} =0V or 5.5V	-0.1		0.1	μA
f _{OSC}	Oscillator Frequency	EXT1,2 Pins at no load, V _{IN} =3.3V	160	200	240	kHz
I _{DD1}	Supply Current	V _{IN} =5.5V, EXT1,2 pins at no load		0.7	1.2	mA
R _{EXTH1}	EXT1 "H" ON Resistance	V _{IN} =3.3V, I _{EXT} =-20mA		4.0	8.0	Ω
R _{EXTL1}	EXT1 "L" ON Resistance	V _{IN} =3.3V, I _{EXT} =20mA		2.7	5.0	Ω
R _{EXTH2}	EXT2 "H" ON Resistance	V _{IN} =3.3V, I _{EXT} =-20mA		4.0	8.0	Ω
R _{EXTL2}	EXT2 "L" ON Resistance	V _{IN} =3.3V, I _{EXT} =20mA		3.7	8.0	Ω
T _{DLY}	Delay Time for Protection	V _{IN} =3.3V, V _{FB1} =1.1V→0V	50	100	150	ms
V _{UVLOD}	UVLO Detector Threshold		2.10	2.20	2.35	V
V _{UVLO}	UVLO Released Voltage			V _{UVLOD} +0.10	2.45	V
V _{DTC10}	CH1 Duty=0%	V _{IN} =3.3V	0.15	0.25	0.35	V
V _{DTC1100}	CH1 Duty=100%	V _{IN} =3.3V	1.1	1.2	1.3	V
V _{DTC20}	CH2 Duty=0%	V _{IN} =3.3V	0.15	0.25	0.35	V
V _{DTC2100}	CH2 Duty=100%	V _{IN} =3.3V	1.1	1.2	1.3	V
A _{V1}	CH1 Open Loop Gain	V _{IN} =3.3V		110		dB
F _{T1}	CH1 Single Gain Frequency Band	V _{IN} =3.3V, A _{V1} =0dB		1.9		MHz
V _{ICR1}	CH1 Input Voltage Range	V _{IN} =3.3V		0.7 to V _{IN}		V
I _{AMPL}	CH1 Sink Current	V _{IN} =3.3V, V _{AMP_{OUT}1} =1.0V, V _{FB1} =V _{FB1} + 0.1V	70	115		μA
I _{AMPH}	CH1 Source Current	V _{IN} =3.3V, V _{AMP_{OUT}1} =1.0V, V _{FB1} =V _{FB1} - 0.1V		-1.4	-0.7	mA
A _{V2}	CH2 Open Loop Gain	V _{IN} =3.3V		60		dB
F _{T1}	CH2 Single Gain Frequency Band	V _{IN} =3.3V, A _{V2} =0dB		3		MHz
V _{ICR1}	CH2 Input Voltage Range	V _{IN} =3.3V		-0.2 to V _{IN} -1.3		V
V _{FB2}	CH2 Input Offset Voltage	V _{IN} =3.3V	-12		12	mV

Operation of Step-up DC/DC Converter and Output Current

Step-up DC/DC Converter makes higher output voltage than input voltage by releasing the energy accumulated during on time of L_x Transistor on input voltage.

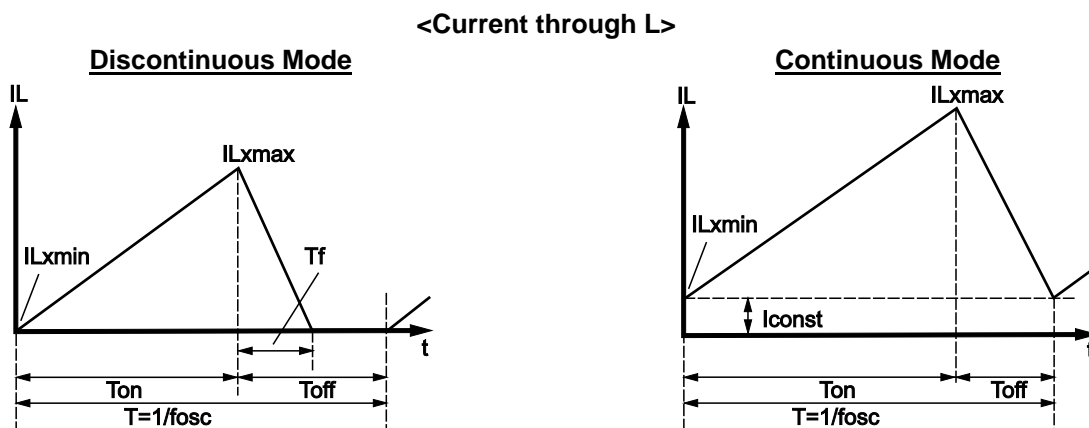
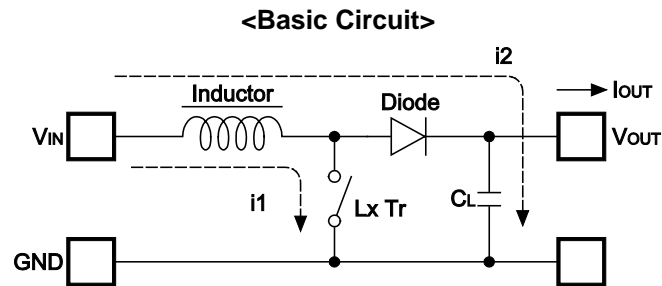

Step 1. L_x Tr. is on, then the current $I_L=i_1$ flows, and the energy is charged in L. In proportion to the on time of L_x Tr. (T_{on}), $I_L=i_1$ increases from $I_L=I_{Lxmin}=0$ and reaches I_{Lxmax} .

Step 2. When the L_x Tr. is off, L turns on Schottky Diode (SD), and $I_L=i_2$ flows to maintain $I_L=I_{Lxmax}$.

Step 3. $I_L=i_2$ gradually decreases, and after T_f passes, $I_L=I_{Lxmin}=0$ is true, then SD turns off. Note that in the case of the continuous mode, before $I_L=I_{Lxmin}=0$ is true, T_{off} passes, and the next cycle starts, then L_x Tr. turns on again.

In this case, $I_{Lxmin}>0$, therefore $I_L=I_{Lxmin}>0$ is another starting point and $I_{Lx max}$ increases.

With the PWM controller, switching times during the time unit are fixed. By controlling T_{on} , output voltage is maintained.

Output Current and Selection of External Components

Output Current of Step-up Circuit and External Components

There are two modes, or discontinuous mode and continuous mode for the PWM step-up switching regulator depending on the continuous characteristic of inductor current.

During on time of the transistor, when the voltage added on to the inductor is described as V_{IN} , the current is $V_{IN} \times t/L$.

Therefore, the electric power, P_{ON} , which is supplied with input side, can be described as in next formula.

$$P_{ON} = \int_0^{T_{on}} V_{IN}^2 \times t/L \, dt \quad \dots\dots\dots \text{Formula 1}$$

With the step-up circuit, electric power is supplied from power source also during off time. In this case, input current is described as $(V_{OUT}-V_{IN}) \times t/L$, therefore electric power, P_{OFF} is described as in next formula.

$$P_{OFF} = \int_0^{T_f} V_{IN} \times (V_{OUT} - V_{IN}) t/L \, dt \quad \dots\dots\dots \text{Formula 2}$$

In this formula, T_f means the time of which the energy saved in the inductance is being emitted. Thus average electric power, P_{AV} is described as in the next formula.

$$P_{AV} = 1/(T_{on} + T_{off}) \times \left\{ \int_0^{T_{on}} V_{IN}^2 \times t/L \, dt + \int_0^{T_f} V_{IN} \times (V_{OUT} - V_{IN}) t/L \, dt \right\} \quad \dots\dots\dots \text{Formula 3}$$

In PWM control, when $T_f = T_{off}$ is true, the inductor current becomes continuous, then the operation of switching regulator becomes continuous mode.

In the continuous mode, the deviation of the current is equal between on time and off time.

$$V_{IN} \times T_{on}/L = (V_{OUT} - V_{IN}) \times T_{off}/L \quad \dots\dots\dots \text{Formula 4}$$

Further, the electric power, P_{AV} is equal to output electric power, $V_{OUT} \times I_{OUT}$, thus,

$$I_{OUT} = f_{osc} \times V_{IN}^2 \times T_{on}^2 / \{2 \times L \times (V_{OUT} - V_{IN})\} = V_{IN}^2 \times T_{on} / (2 \times L \times V_{OUT}) \quad \dots\dots\dots \text{Formula 5}$$

When I_{OUT} becomes more than $V_{IN} \times T_{on} \times T_{off} / (2 \times L \times (T_{on} + T_{off}))$, the current flows through the inductor, then the mode becomes continuous. The continuous current through the inductor is described as

I_{const} , then,

$$I_{OUT} = f_{osc} \times V_{IN}^2 \times T_{on}^2 / (2 \times L \times (V_{OUT} - V_{IN})) + V_{IN} \times I_{const} / V_{OUT} \quad \dots\dots\dots \text{Formula 6}$$

In this moment, the peak current, I_{Lxmax} flowing through the inductor and the driver T_r is described as follows:

$$I_{Lxmax} = I_{const} + V_{IN} \times T_{on} / L \dots\dots\dots \text{Formula 7}$$

With the formula 4,6, and I_{Lxmax} is,

$$I_{Lxmax} = V_{OUT} / V_{IN} \times I_{OUT} + V_{IN} \times T_{on} / (2 \times L) \dots\dots\dots \text{Formula 8}$$

Therefore, peak current is more than I_{OUT} . Considering the value of I_{Lxmax} , the condition of input and output, and external components should be selected.

In the formula 7, peak current I_{Lxmax} at discontinuous mode can be calculated. Put $I_{const}=0$ in the formula.

The explanation above is based on the ideal calculation, and the loss caused by L_x switch and external components is not included. The actual maximum output current is between 50% and 80% of the calculation. Especially, when the I_{Lx} is large, or V_{IN} is low, the loss of V_{IN} is generated with the on resistance of the switch. As for V_{OUT} , V_f (as much as 0.3V) of the diode should be considered.

Operation of Inverting DC/DC converter and Output Current

Inverting DC/DC converter saves energy during on time of Lx transistor, and supplies the energy to output during off time, output voltage opposed to input voltage is obtained.

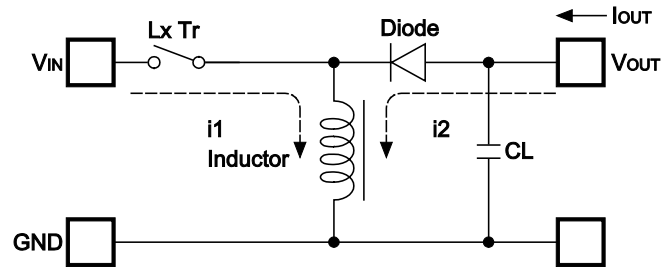

<Current through L>

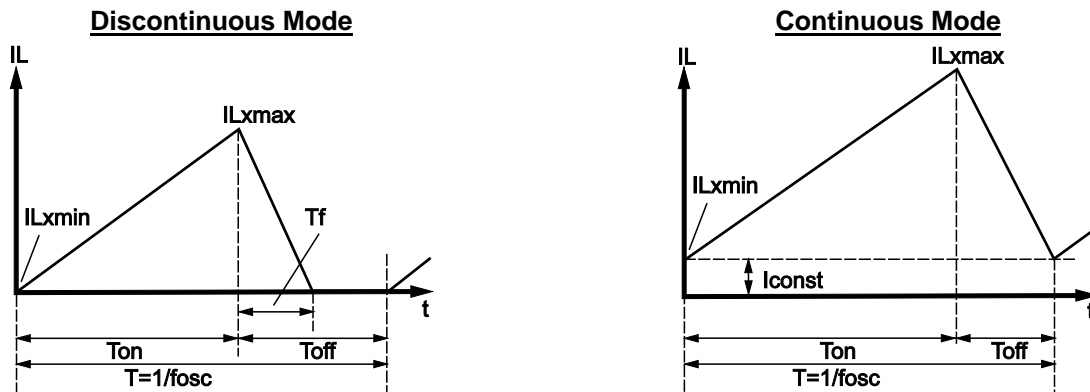

Step 1. Lx Tr. turns on, current, $IL=i1$ flows, energy is charged in L. In proportion to the on time, T_{on} , of Lx Tr. $IL=i1$ increases from $IL=IL_{xmin}=0$ and reaches IL_{xmax} .

Step 2. When the Lx Tr. turns off, L turns on Shottky diode (SD) and flow $IL=i2$ to maintain $IL = IL_{xmax}$.

Step 3. $IL=i2$ decreases gradually, after T_f passes, $IL=IL_{xmin}=0$ is true, then SD turns off. Note that in the case of continuous mode, before $IL=IL_{xmin}=0$ is true, T_{off} passes and next cycle starts, then Lx Tr. turns on. In this case, $IL_{xmin}>0$, therefore IL increases from $IL=IL_{xmin}>0$.

With the PWM controller, switching time (f_{osc}) in the time unit is fixed, and by controlling T_{on} , output voltage is maintained.

Output Current and Selection of External Components

There are also two modes, or discontinuous mode and continuous mode for the PWM inverting switching regulator depending on the continuous characteristic of inductor current.

During on time of the transistor, when the voltage added on to the inductor is described as V_{IN} , the current is $V_{IN} \times t/L$.

Therefore, the electric power, P , which is supplied with input side, can be described as in next formula.

$$P = \int_0^{T_{on}} V_{IN}^2 \times t/L dt \quad \dots\dots\dots \text{Formula 9}$$

Thus average electric power in one cycle, P_{AV} is described as in the next formula.

$$P_{AV} = 1/(T_{on} + T_{off}) \times \int_0^{T_{on}} V_{IN}^2 \times t/L dt = V_{IN}^2 \times T_{on}^2 / (2 \times L \times (T_{on} + T_{off})) \quad \dots\dots\dots \text{Formula 10}$$

This electric power P_{AV} equals to output electric power $V_{OUT} \times I_{OUT}$, thus,

$$I_{OUT} = f_{osc} \times V_{IN}^2 \times T_{on}^2 / (2 \times L \times V_{OUT}) \quad \dots\dots\dots \text{Formula 11}$$

When I_{OUT} becomes more than $V_{IN} \times T_{on} \times T_{off} / (2 \times L \times (T_{on} + T_{off}))$, the current flows through the inductor continuously, then the mode becomes continuous. In the continuous mode, the deviation of the current equals between T_{on} and T_{off} , therefore,

$$V_{IN} \times T_{on} / L = V_{OUT} \times T_{off} / L \quad \dots\dots\dots \text{Formula 12}$$

In this moment, the current flowing continuously through L , is assumed as I_{const} , I_{OUT} is described as in the next formula:

$$I_{OUT} = f_{osc} \times V_{IN}^2 \times T_{on}^2 / (2 \times L \times V_{OUT}) + T_{on} / (T_{on} + T_{off}) \times V_{IN} \times I_{const} / V_{OUT} \quad \dots\dots\dots \text{Formula 13}$$

In this moment, the peak current, I_{Lxmax} flowing through the inductor and the driver Tr . is described as follows:

$$I_{Lxmax} = I_{const} + V_{IN} \times T_{on} / L \quad \dots\dots\dots \text{Formula 14}$$

With the formula 12,13, I_{Lxmax} is,

$$I_{Lxmax} = (T_{on} + T_{off}) / T_{off} \times I_{OUT} + V_{IN} \times T_{on} / (2 \times L) \quad \dots\dots\dots \text{Formula 15}$$

Therefore, peak current is more than I_{OUT} . Considering the value of I_{Lxmax} , the condition of input and output, and external components should be selected.

In the formula 14, peak current I_{Lxmax} at discontinuous mode can be calculated. Put $I_{const}=0$ in the formula.

The explanation above is based on the ideal calculation, and the loss caused by L_x switch and external components is not included. The actual maximum output current is between 50% and 80% of the calculation. Especially, when the I_{Lx} is large, or V_{IN} is low, the loss of V_{IN} is generated with the on resistance of the switch. As for V_{OUT} , V_f (as much as 0.3V) of the diode should be considered.

TEST CIRCUITS

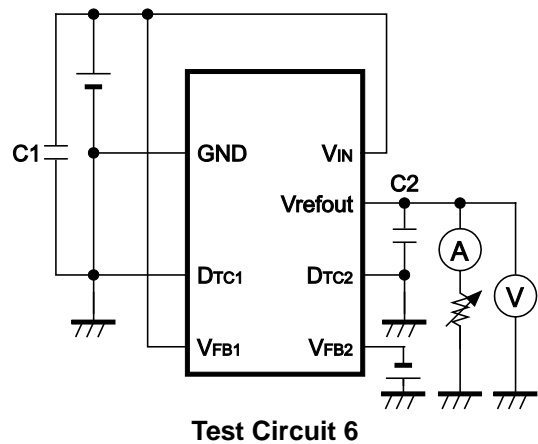
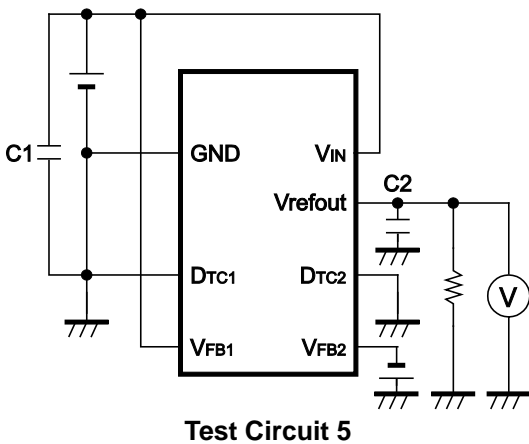
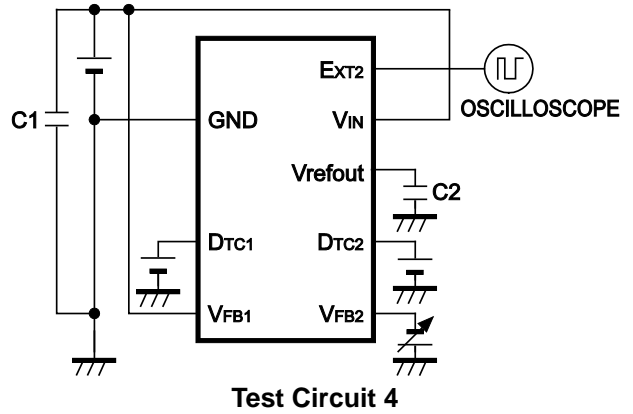
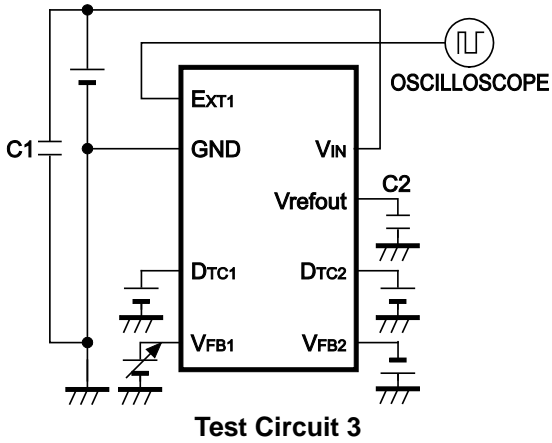
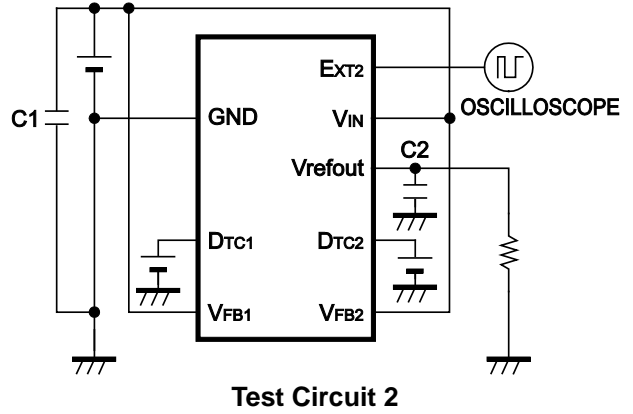
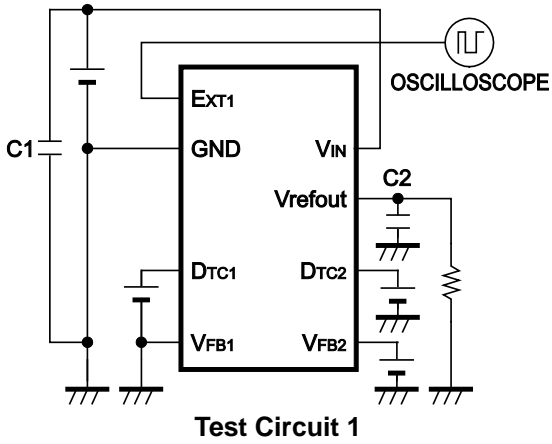

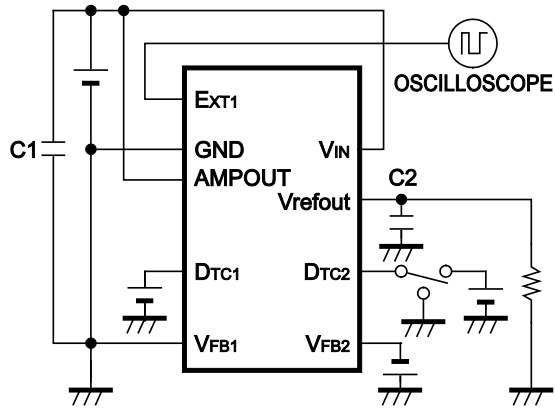

Test Circuit 7

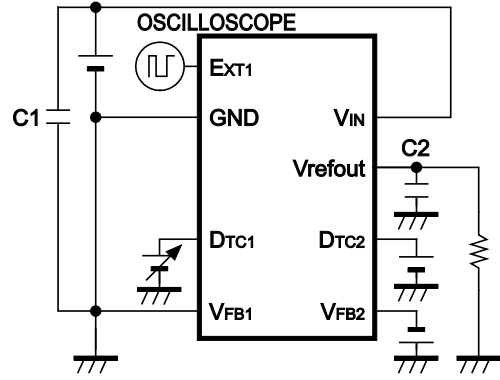

Test Circuit 8

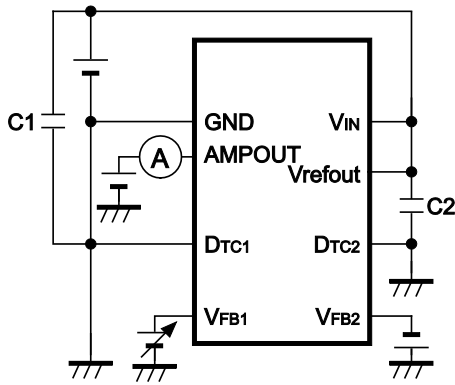

Test Circuit 9

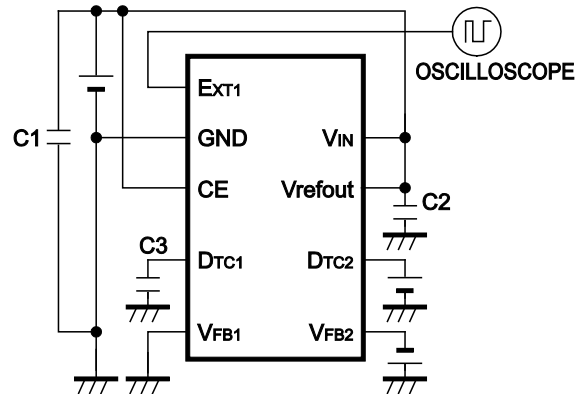

Test Circuit 10

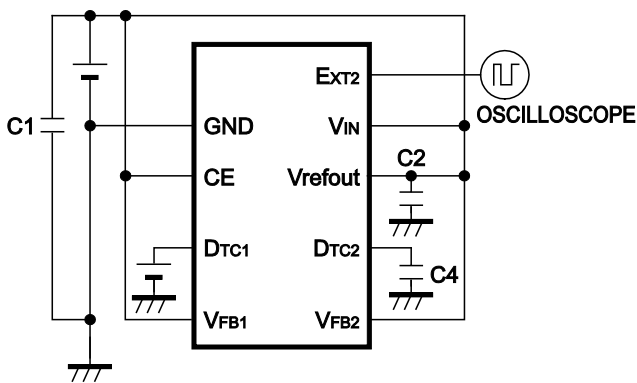

Test Circuit 11

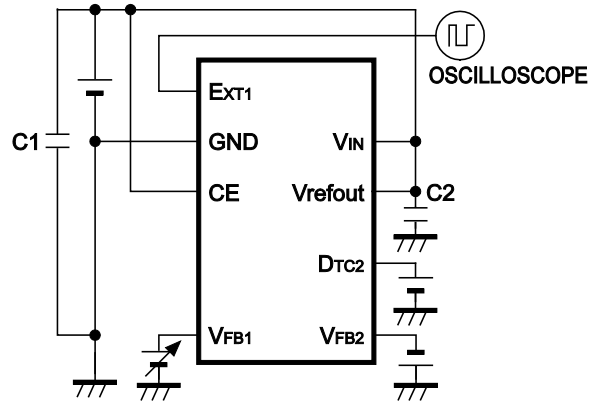

Test Circuit 12

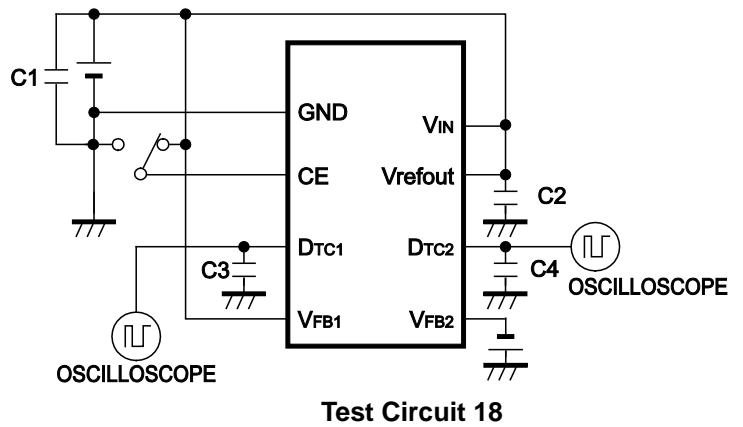
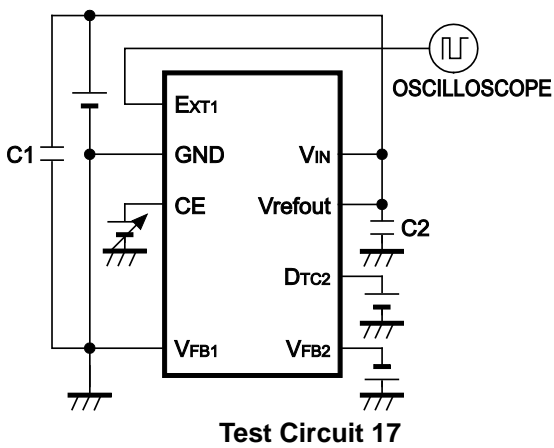
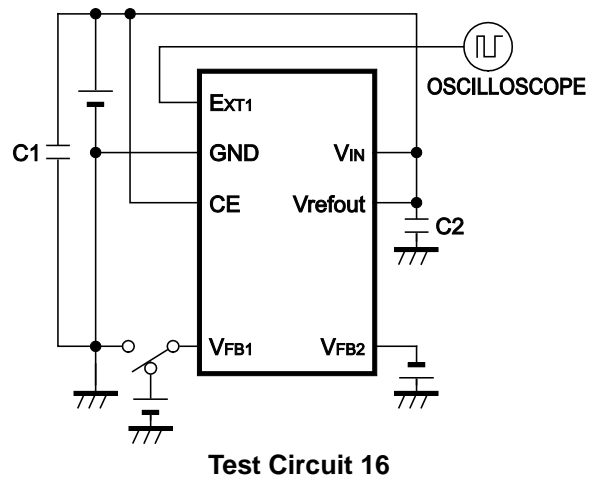
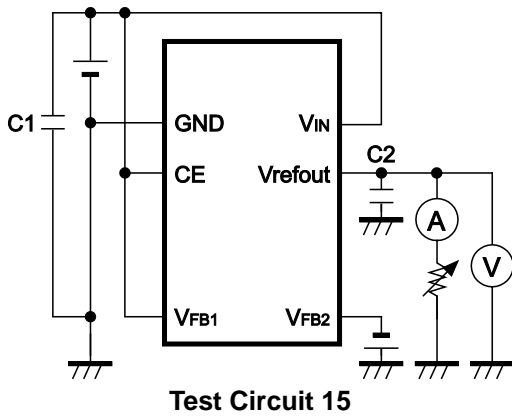
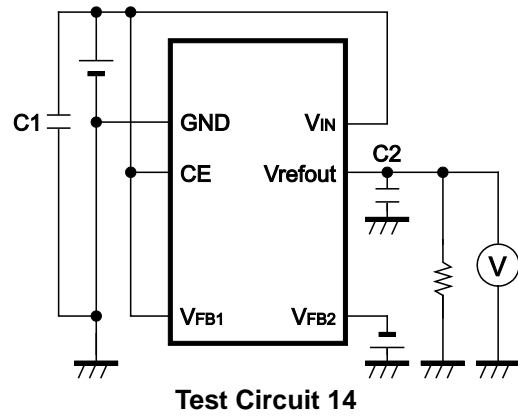
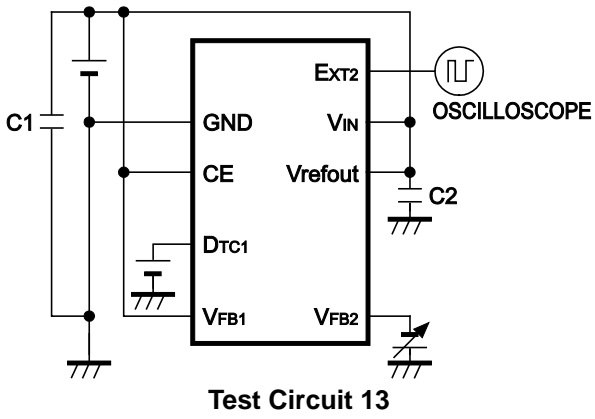

Typical Characteristics shown in the following pages are obtained with test circuits shown above.

● **R1280D002A/C**

- Test Circuit 1,2 : Typical Characteristic 4)
- Test Circuit 3 : Typical Characteristic 6)
- Test Circuit 4 : Typical Characteristic 7)
- Test Circuit 5 : Typical Characteristic 8)
- Test Circuit 6 : Typical Characteristics 9) 10)
- Test Circuit 7 : Typical Characteristic 11)
- Test Circuit 8 : Typical Characteristic 12)
- Test Circuit 9 : Typical Characteristics 13) 14)

● **R1280D002B**

- Test Circuit 10,11 : Typical Characteristics 4) 5)
- Test Circuit 12 : Typical Characteristic 6)
- Test Circuit 13 : Typical Characteristic 7)
- Test Circuit 14 : Typical Characteristic 8)
- Test Circuit 15 : Typical Characteristics 9) 10)
- Test Circuit 16 : Typical Characteristic 11)
- Test Circuit 17 : Typical Characteristics 15) 16)
- Test Circuit 18 : Typical Characteristics 17) 18)
- Standard Circuit Example: Typical Characteristics 1) 2) 3) 19) 20)

Note) Capacitors' values of test circuits

Capacitors: Ceramic Type:

C1=4.7μF, C2=1.0μF, C3=C4=1000pF

Efficiency η (%) can be calculated with the next formula:

$$\eta = (V_{OUT1} \times I_{OUT1} + V_{OUT2} \times I_{OUT2}) / (V_{IN} \times I_{IN}) \times 100$$

TYPICAL CHARACTERISTICS

1) Output Voltage vs. Output Current

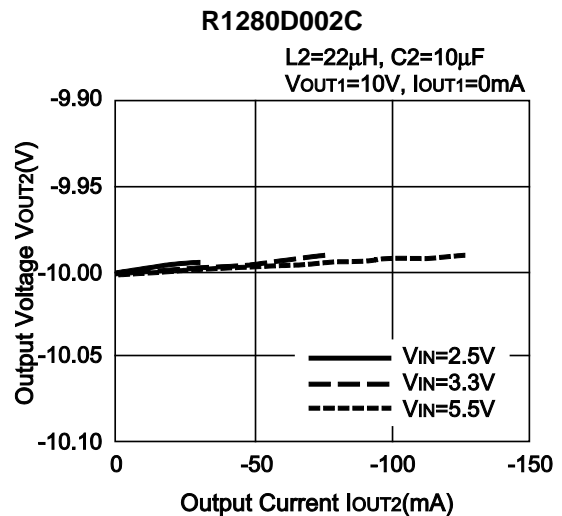
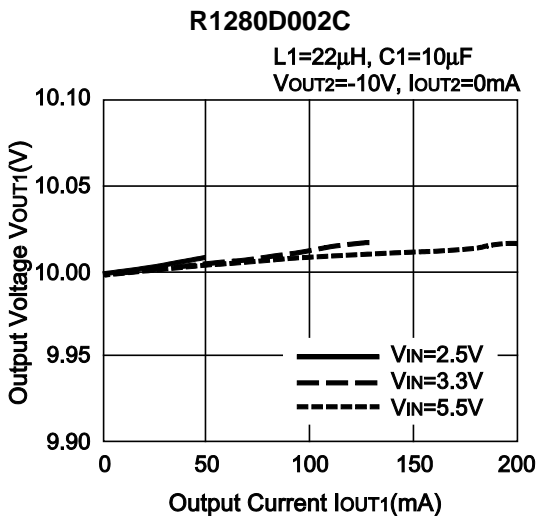
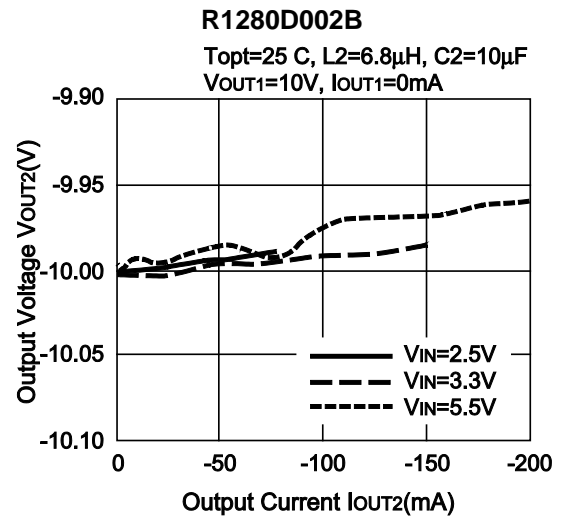
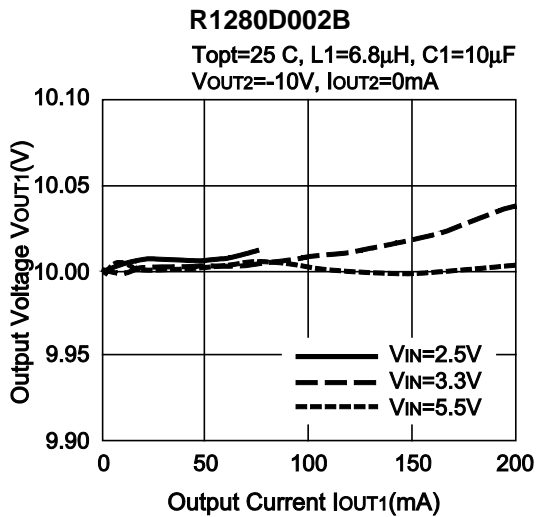
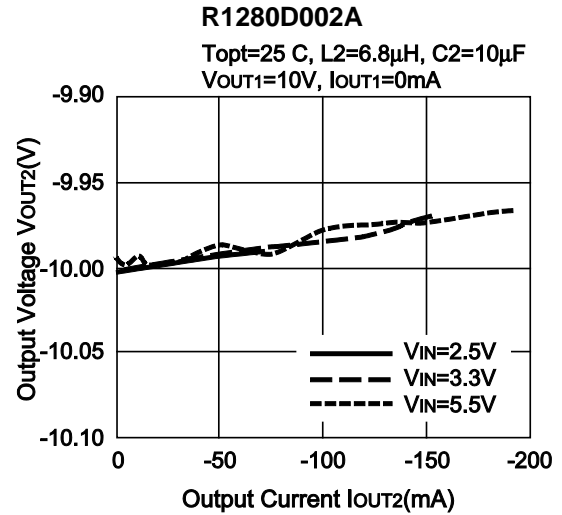
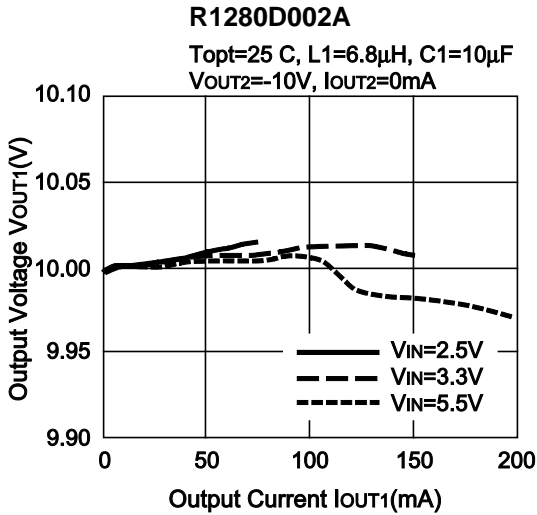

2) Efficiency vs. Output Current

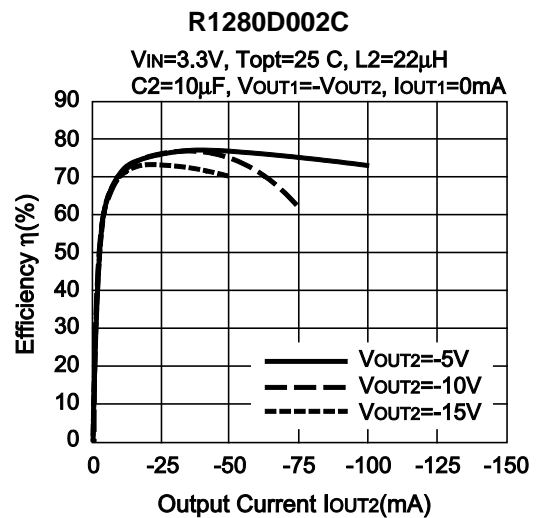
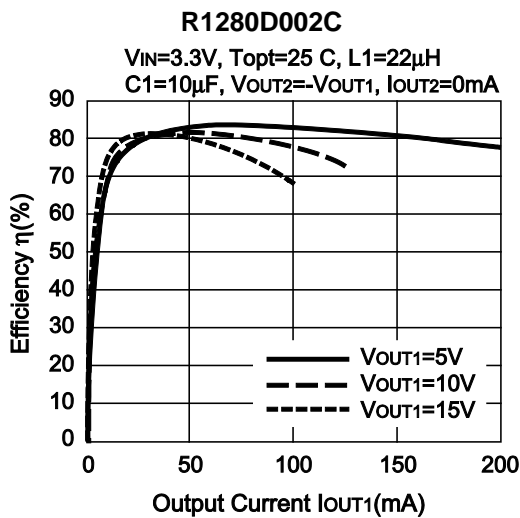
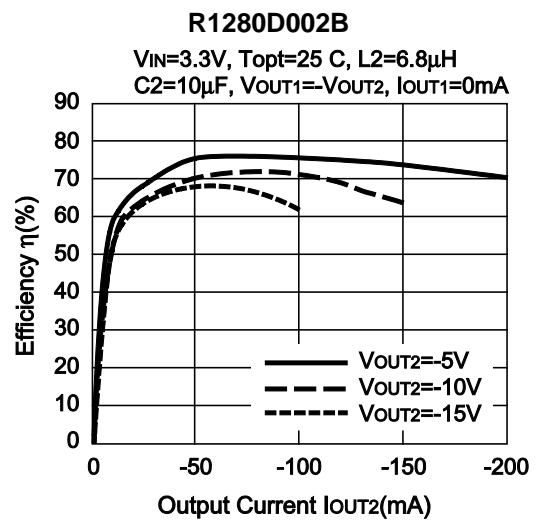
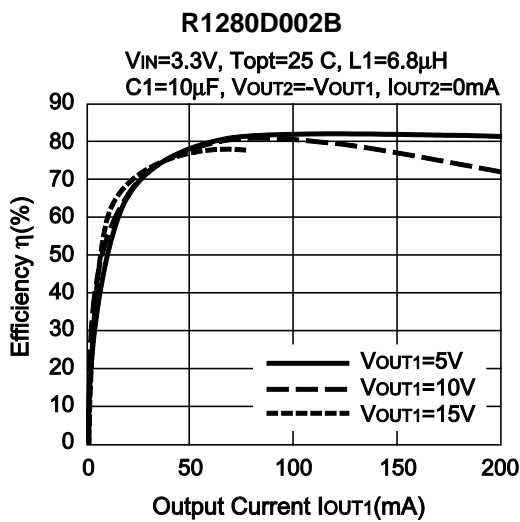
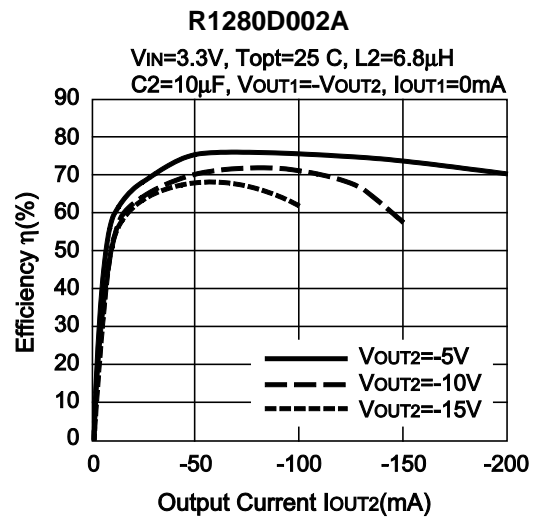
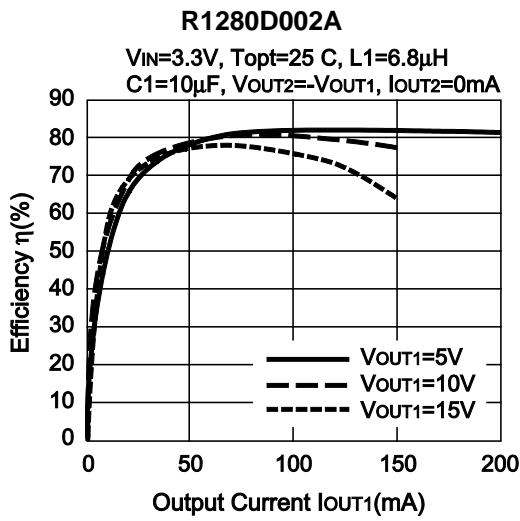

R1280D002x

3) Output Voltage vs. Temperature

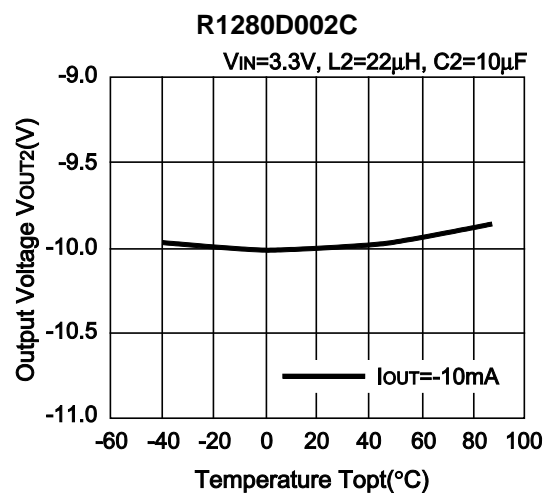
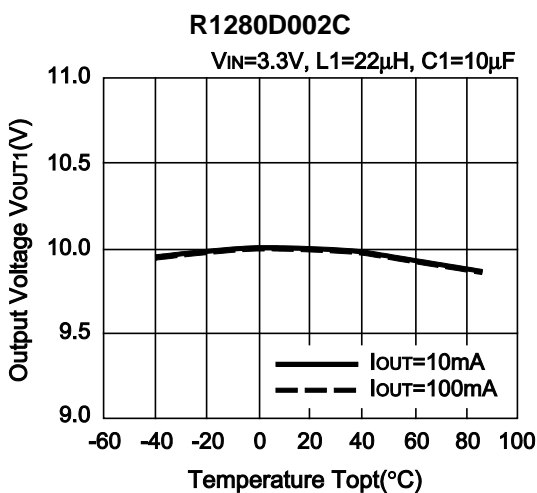
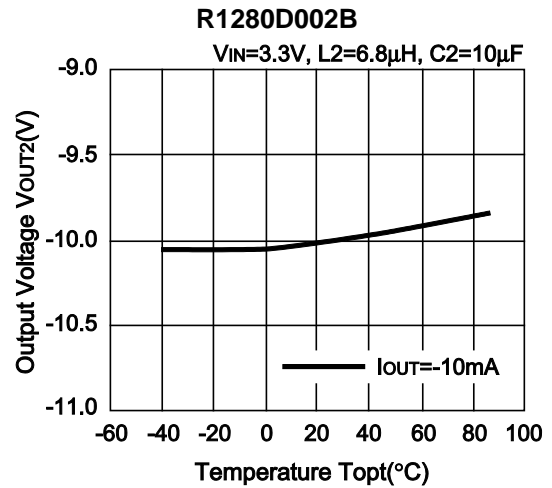
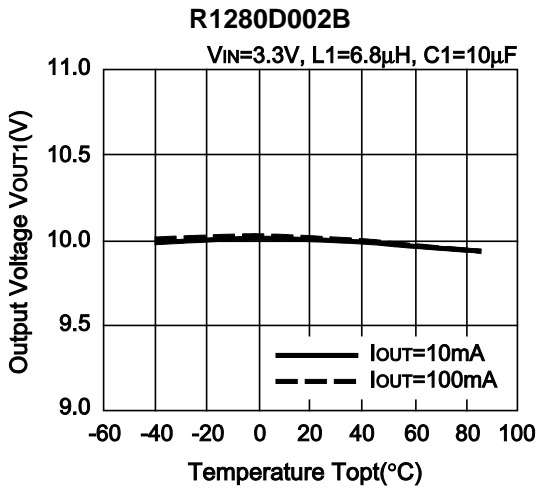
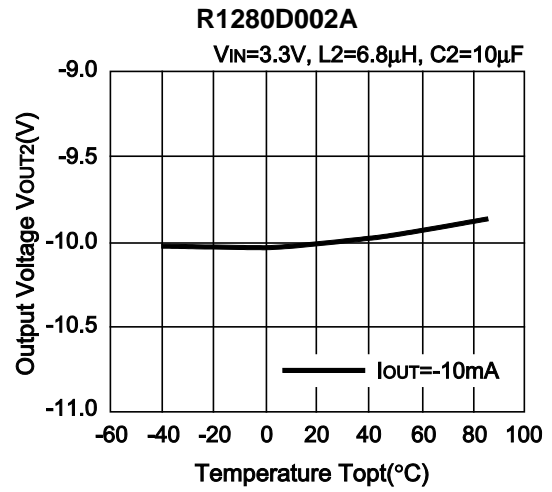
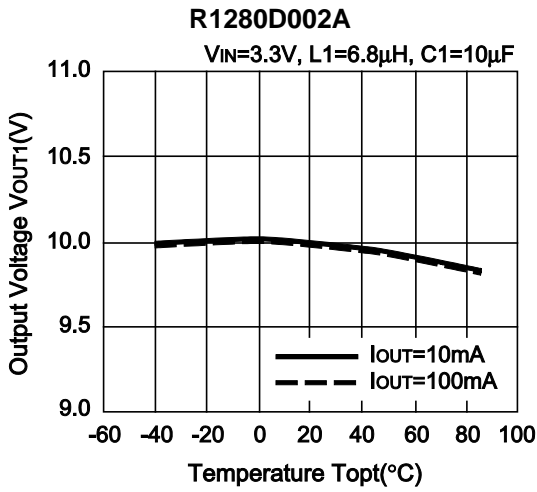

4) Frequency vs. Temperature

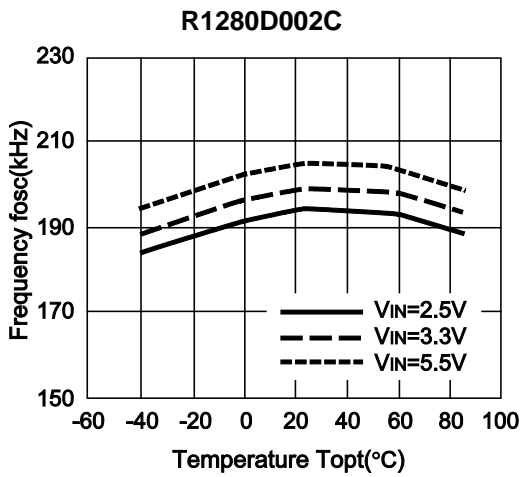
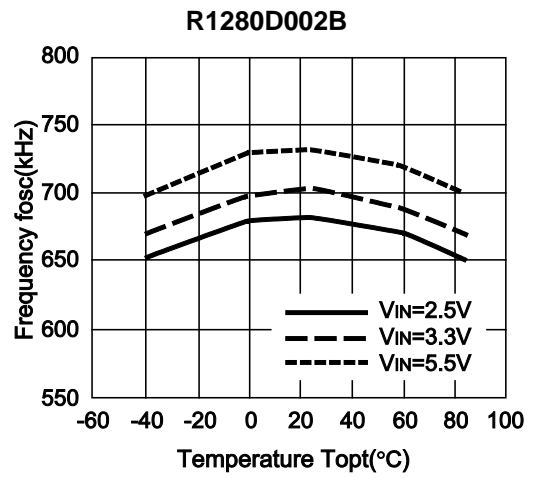
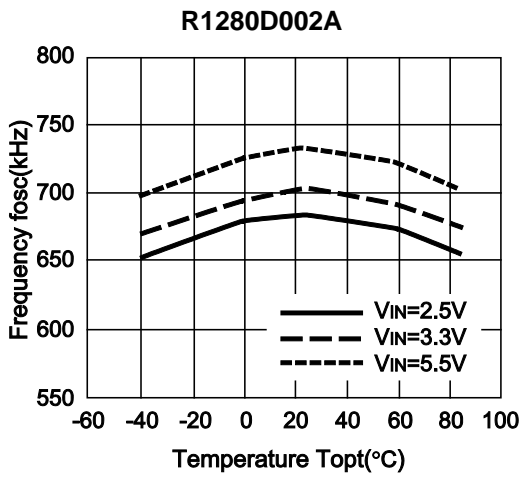

5) Maximum Duty Cycle vs. Temperature

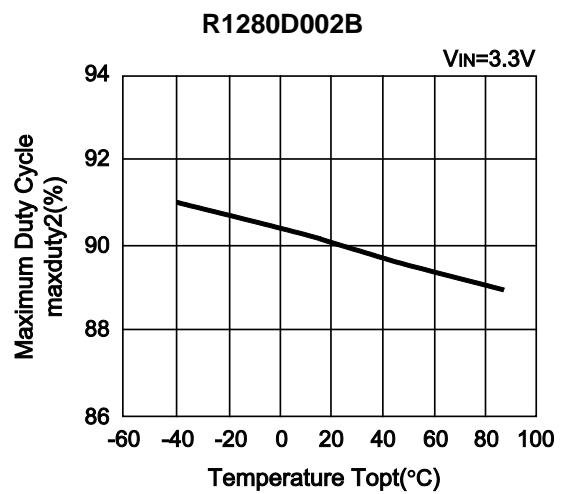
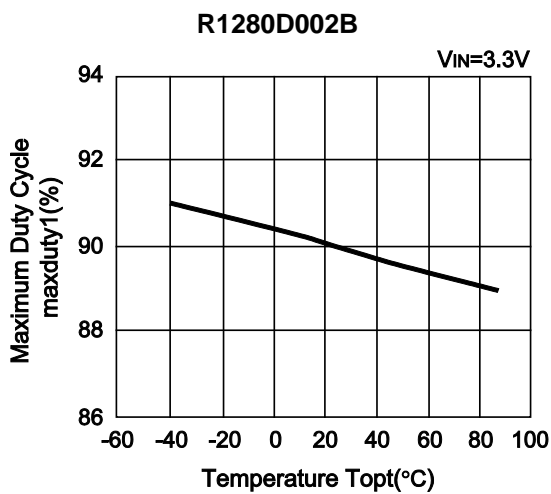

6) Feedback Voltage vs. Temperature

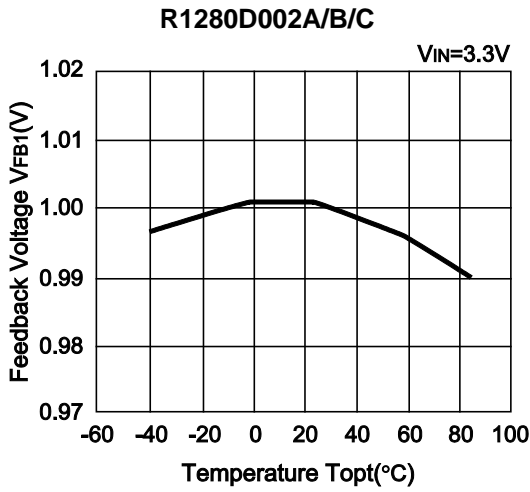

7) Input Offset Voltage vs. Temperature

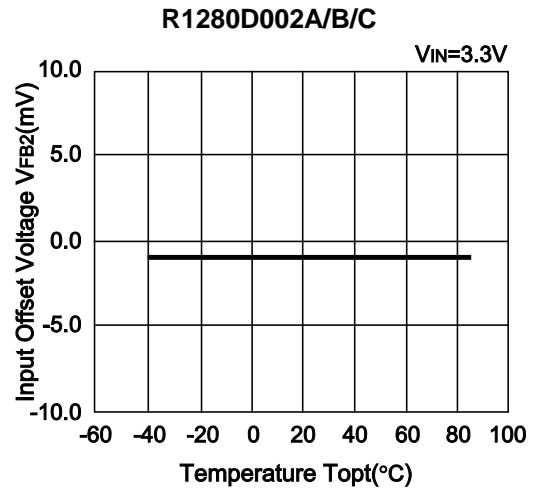

8) Vrefout Output Voltage vs. Temperature

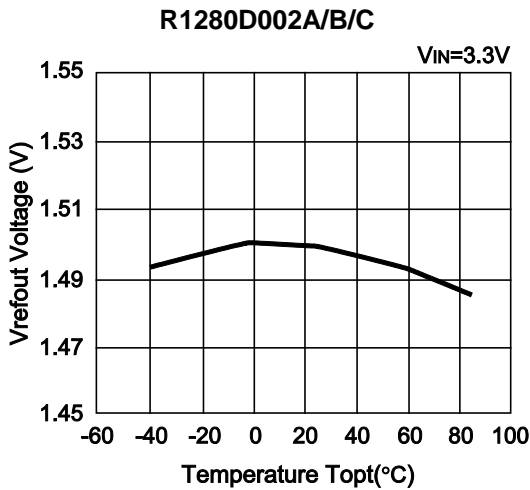

9) Vrefout Output Voltage vs. Output Current

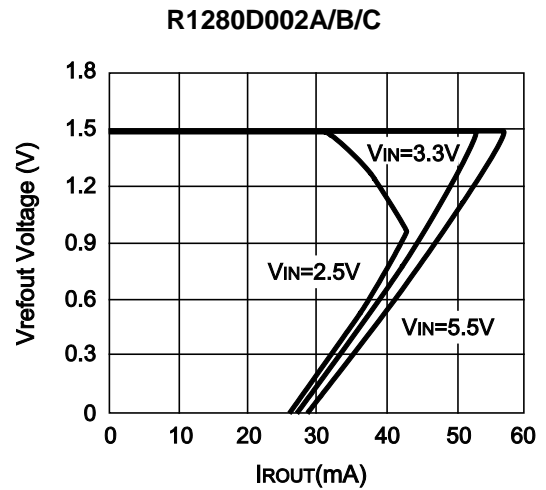

10) Vrefout Output Voltage vs. Output Current

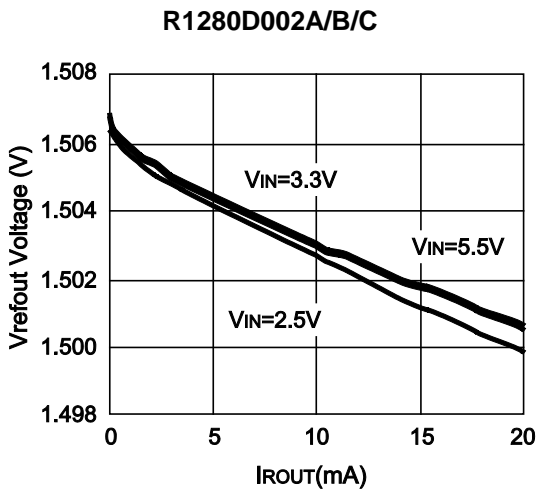

11) Protection Circuit Delay Time vs. Temperature

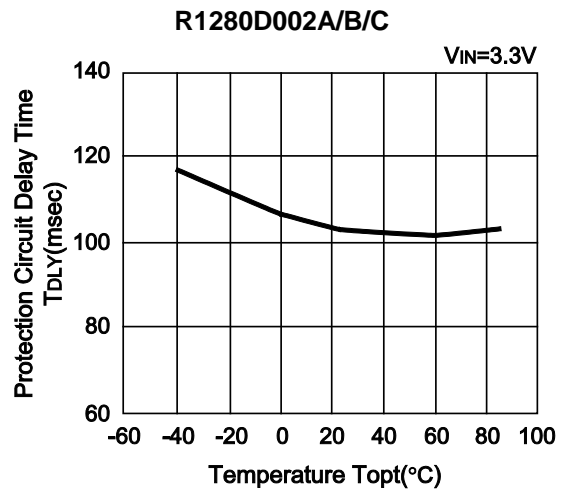

12) Duty Cycle vs. DTC Voltage

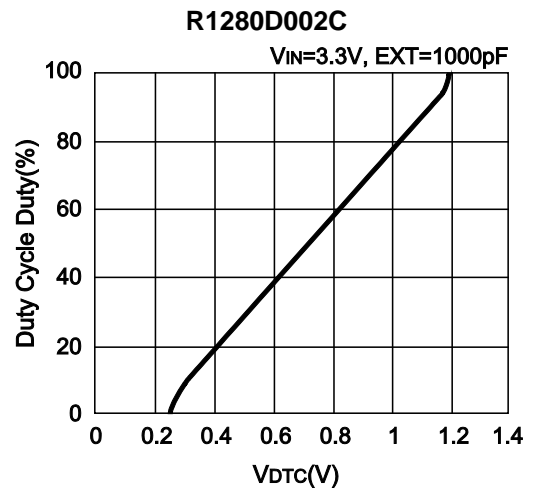
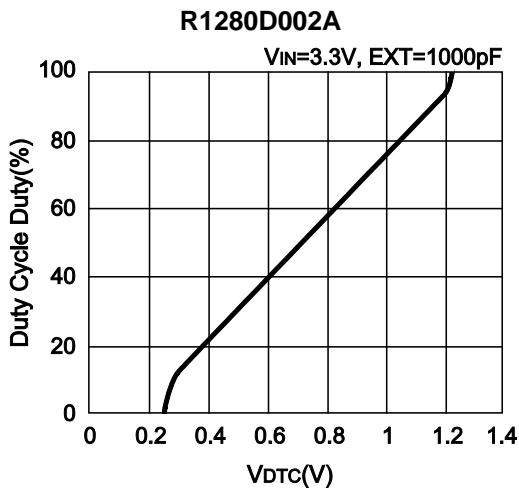

13) Output Sink Current vs. Temperature

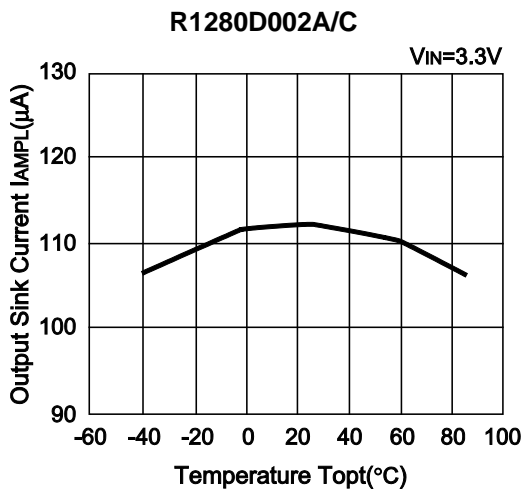

14) Output Source Current vs. Temperature

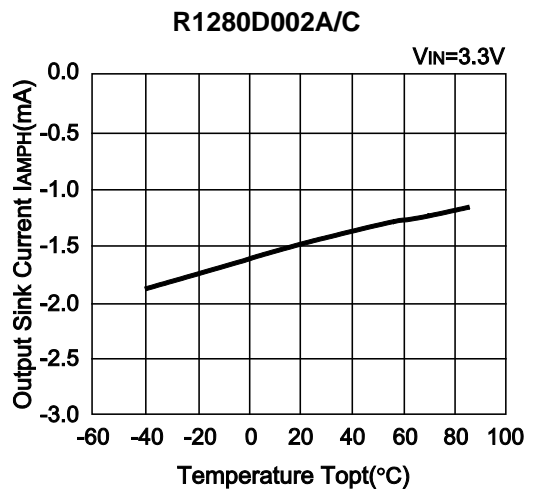

15) CE "H" Input Voltage vs. Temperature

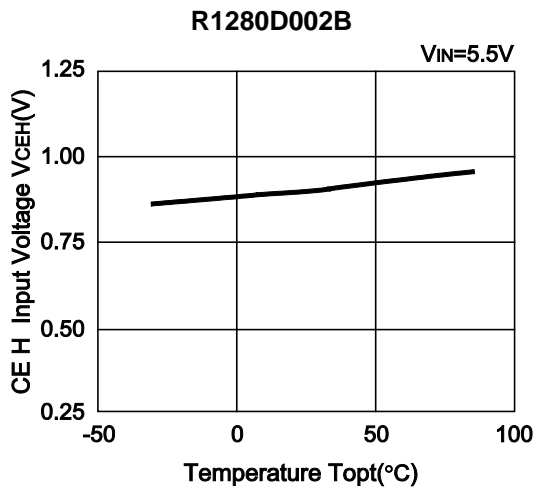

16) CE "L" Input Voltage vs. Temperature

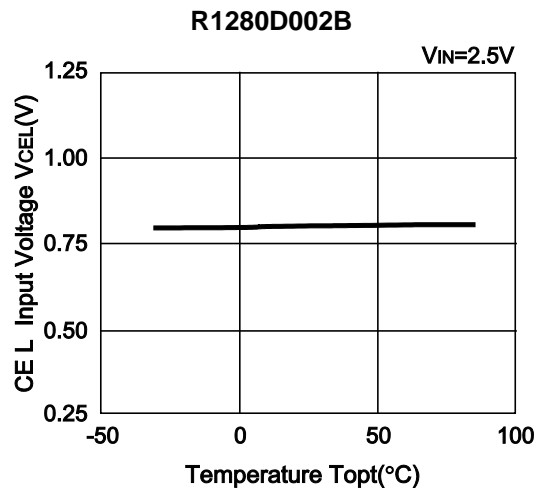

R1280D002x

17) Soft Starting Time vs. Capacitance value

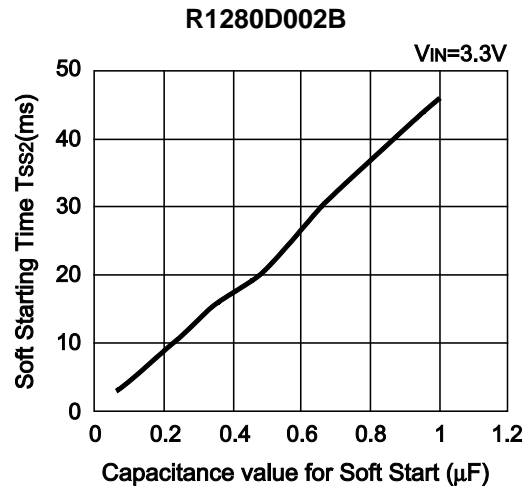
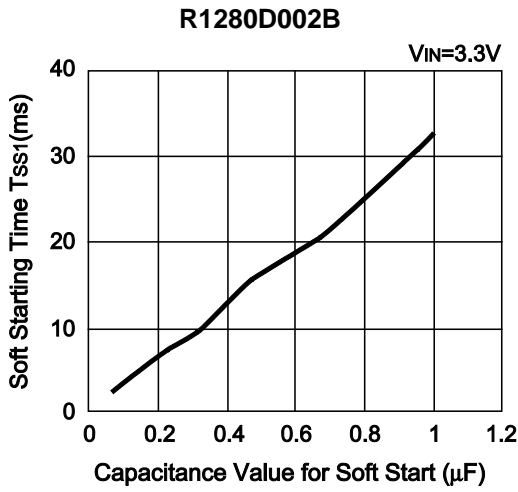

18) Soft Starting Time vs. Temperature

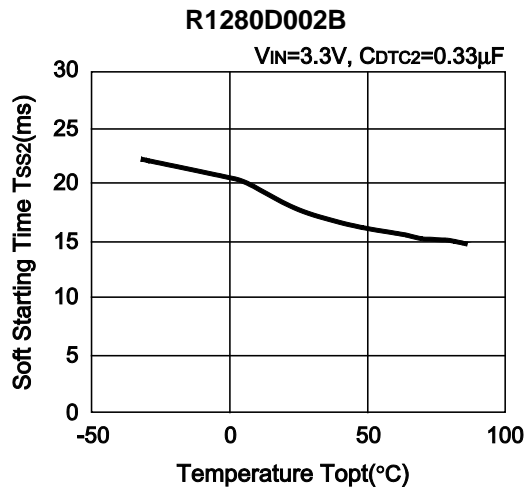
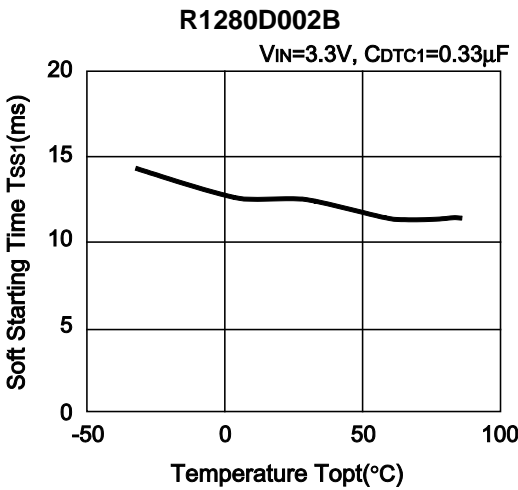

19) Load Transient Response(Step-up Side)

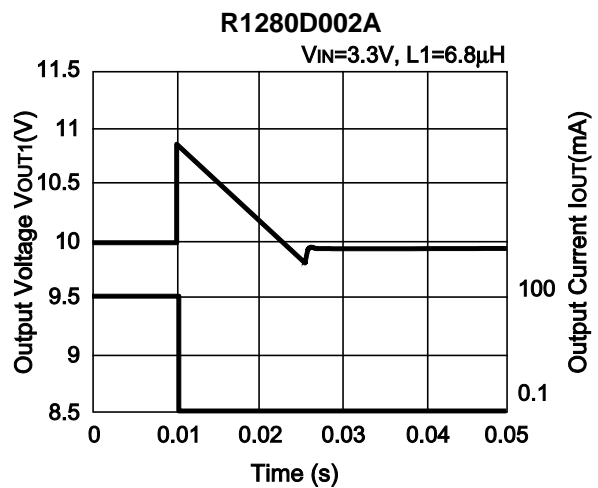
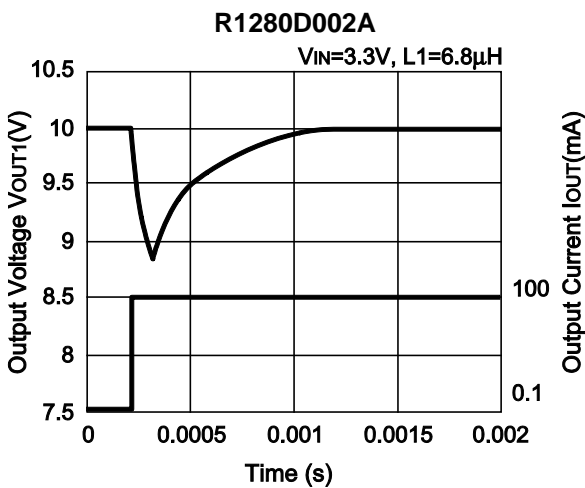

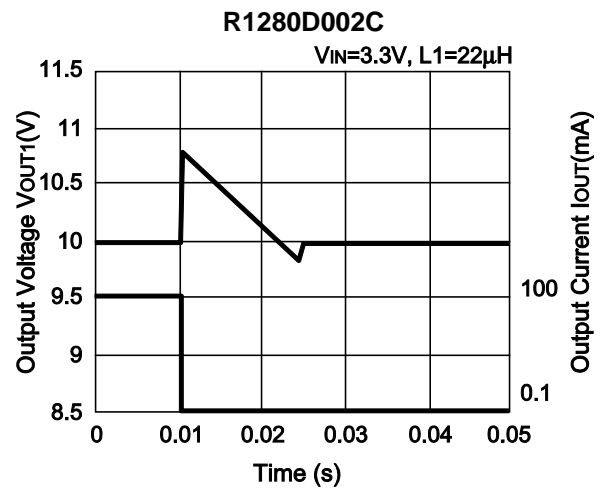
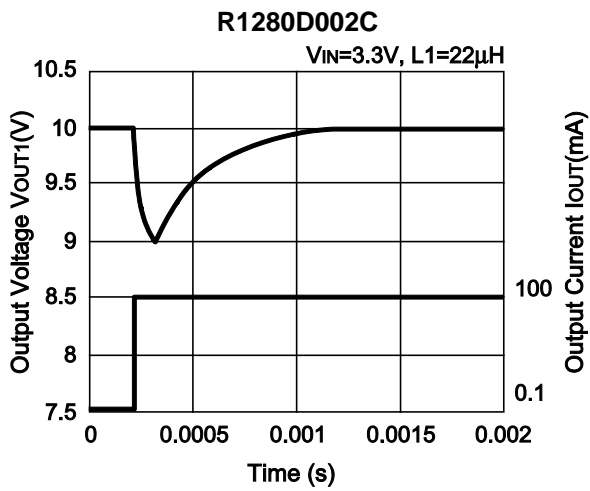
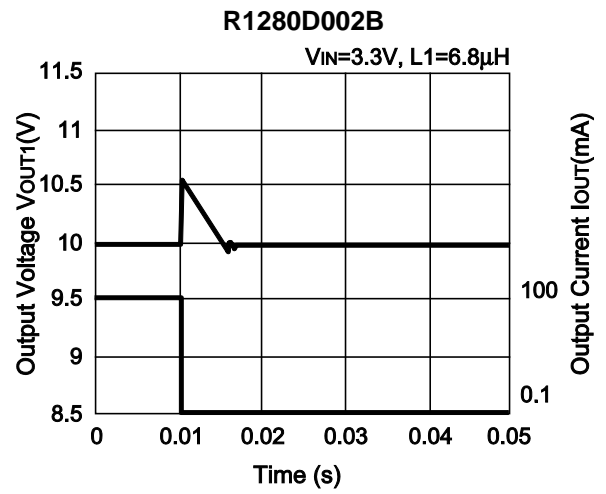
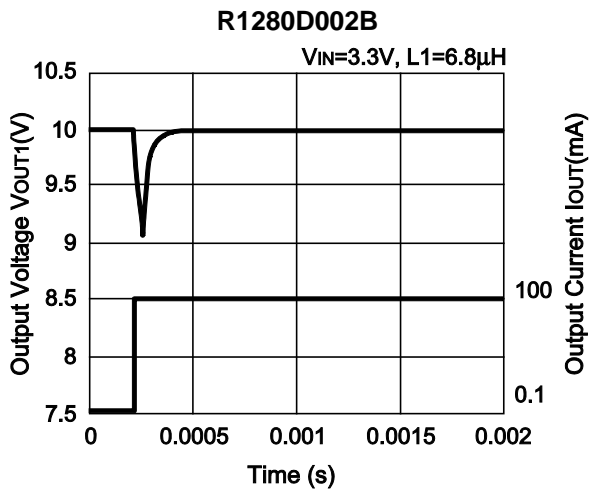

20) Load Transient Response (Inverting Side)

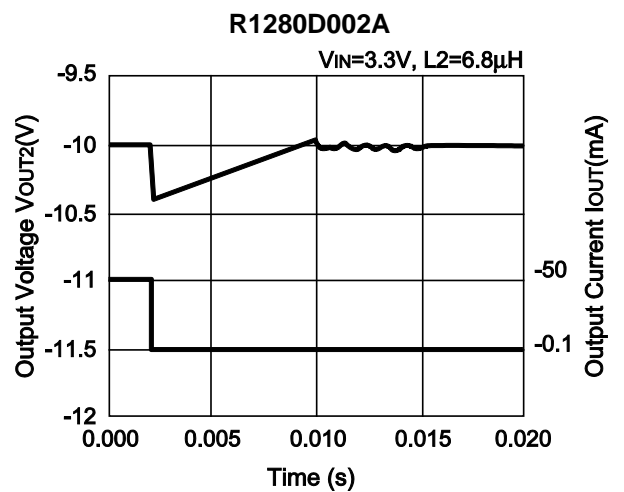
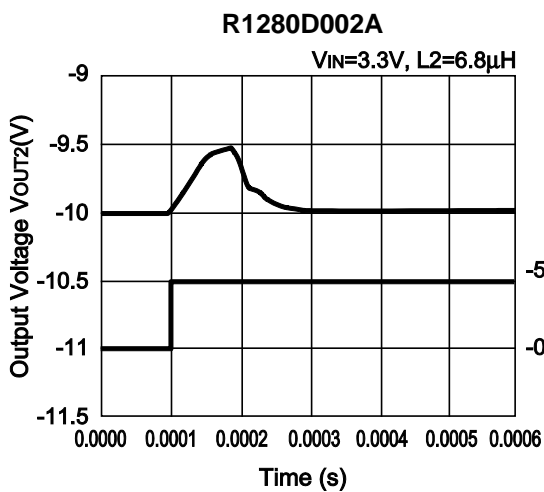

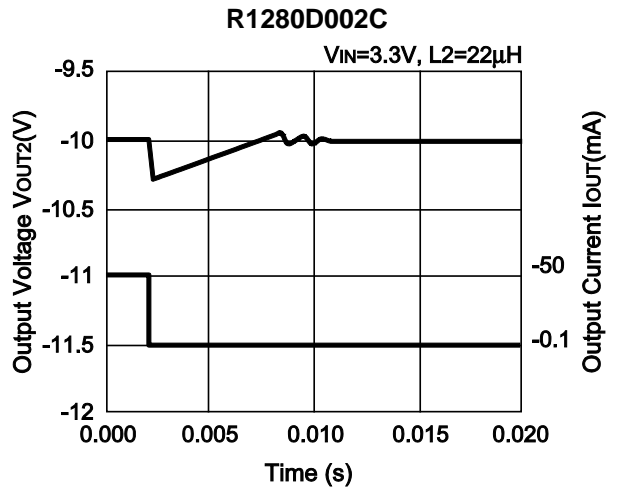
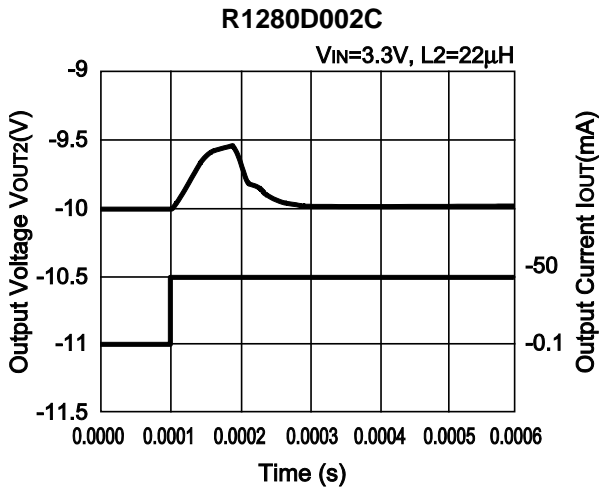
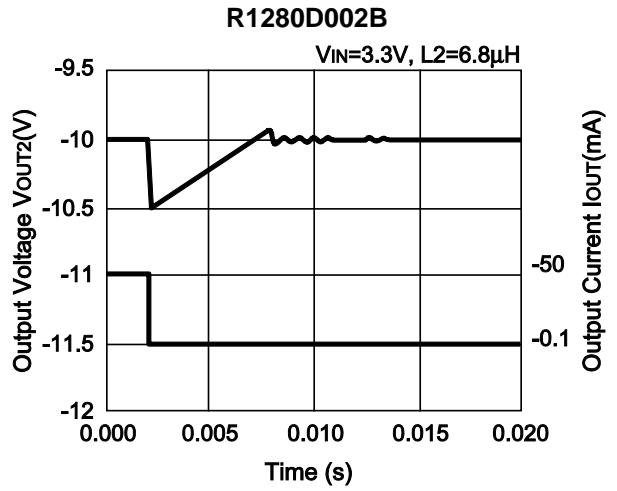
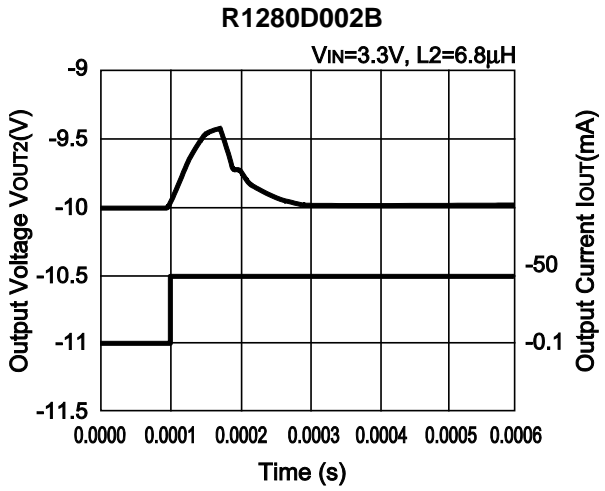

TYPICAL APPLICATION AND TECHNICAL NOTES

• R1280D002A/C

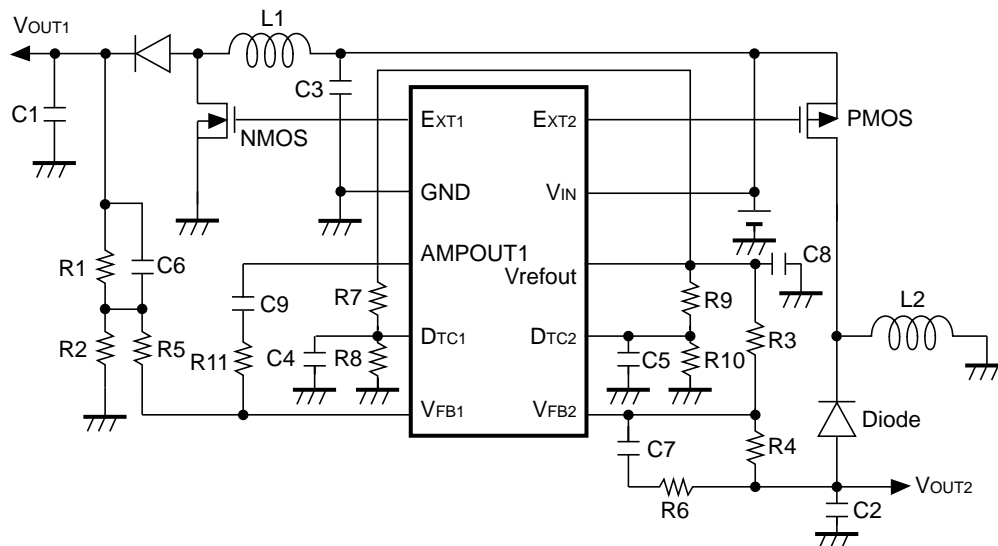

External Components

Inductor L1,2: 6.8 μ H, VLF504012MT (TDK) for A type, 22 μ H for C type

Diode: CRS10I30A (Toshiba)

NMOS: IRF7601 (International Rectifier)

PMOS: Si3443DV (Siliconix)

Resistors: R1, R2, R3, and R4 are for Setting Output Voltage. Recommendation values are $R1+R2 \leq 100k\Omega$ or $R3+R4 \leq 100k\Omega$

$R5=43k\Omega$, $R6=10k\Omega$, $R7=R9=22k\Omega$, $R8=R10=43k\Omega$, $R11=220k\Omega$

Capacitors: Ceramic Capacitor

(Example)

R1280D002A: $C1=C2=10\mu F$, $C3=4.7 F$, $C4=0.22\mu F$, $C5=0.47\mu F$, $C6=120pF$, $C7=50pF$, $C8=1\mu F$, $C9=1000pF$

R1280D002C: $C1=C2=10 F$, $C3=4.7\mu F$, $C4=0.22\mu F$, $C5=0.47\mu F$, $C6=220pF$, $C7=330pF$, $C8=1\mu F$, $C9=1000pF$

Note: Maximum voltage tolerance of each component should be considered. With the transistor shown above is appropriate to set up to $\pm 15V$ as output voltage.

• R1280D002B

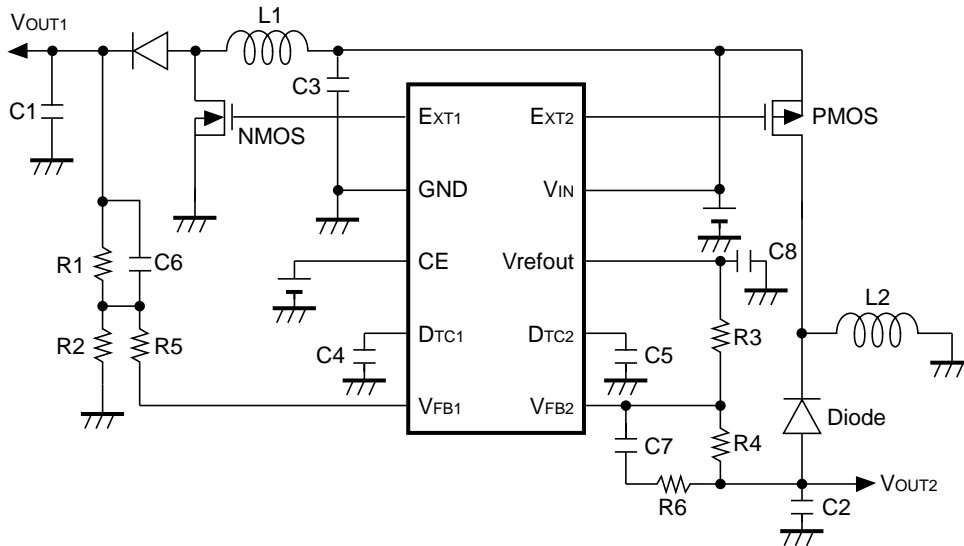

External Components

Inductor L1,2: 6.8 μ H, VLF504012MT (TDK)

Diode: CRS10I30A (Toshiba)

NMOS: IRF7601 (International Rectifier)

PMOS: Si3443DV (Siliconix)

Resistors: R1, R2, R3, and R4 are for Setting Output Voltage. Recommendation values are
 $R1+R2 \leq 100k\Omega$ or $R3+R4 \leq 100k\Omega$
 $R5=43k\Omega$, $R6=10k\Omega$

Capacitors: Ceramic Capacitor

(Example)

$C1=C2=10\mu F$, $C3=4.7\mu F$, $C4=0.33\mu F$, $C5=0.33\mu F$, $C6=120pF$, $C7=50pF$, $C8=1\mu F$

Note: Maximum voltage tolerance of each component should be considered. With the transistor shown above is appropriate to set up to $\pm 15V$ as output voltage.

APPLICATION EXAMPLE

• R1280D002A/C

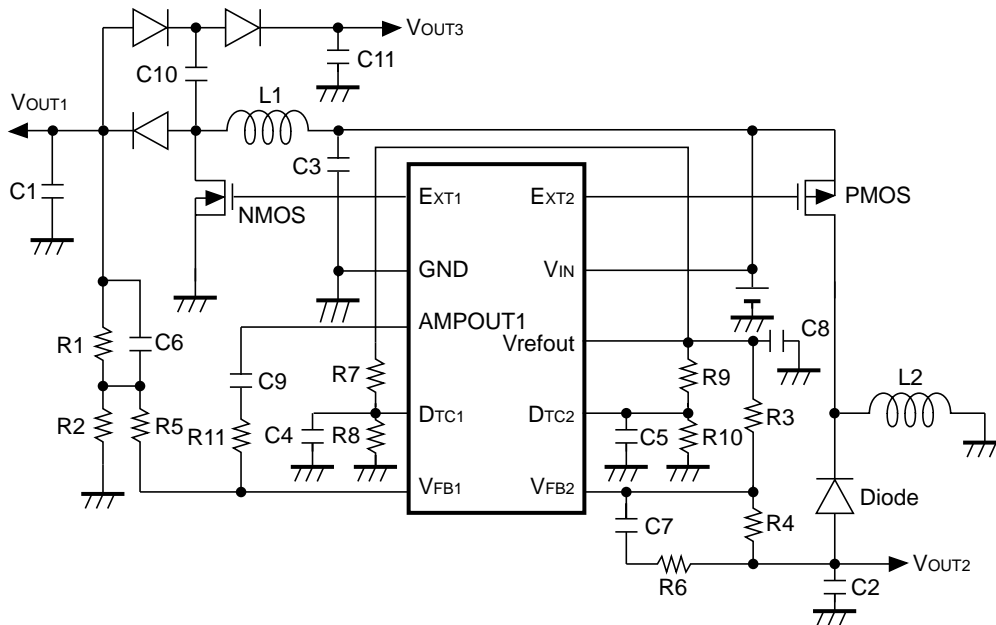

External Components

Inductor L1,2: 6.8 μ H, VLF504012MT (TDK) for A version, 22 μ H for R1280D002C

Diode: CRS10I30A (Toshiba)

NMOS: IRF7601 (International Rectifier)

PMOS: Si3443DV (Siliconix)

Resistors: R1, R2, R3, and R4 are for Setting Output Voltage. Recommendation values are $R1+R2 \leq 100k\Omega$ or $R3+R4 \leq 100k\Omega$
 $R5=43k\Omega$, $R6=10k\Omega$, $R7=R9=22k\Omega$, $R8=R10=43k\Omega$, $R11=220k\Omega$

Capacitors: Ceramic Capacitor

(Example)

R1280D002A: C1=C2=10 μ F, C3=4.7 μ F, C4=0.22 F, C5=0.47 μ F, C6=120pF, C7=50pF,
 C8=C10=C11=1 μ F, C9=1000pF

R1280D002C: C1=C2=10 μ F, C3=4.7 μ F, C4=0.22 μ F, C5=0.47 μ F, C6=220pF, C7=330pF,
 C8=C10=C11=1 μ F, C9=1000pF

This IC can be used 3 Output TFT Bias Circuit as shown above. $V_{OUT3}=2 \times V_{OUT1}-V_f$

Note: Maximum voltage tolerance of each component should be considered. With the transistor shown above is appropriate to set up to +15V as V_{OUT1} , -15V as V_{OUT2} , 30V as V_{OUT3} .

• R1280D002B

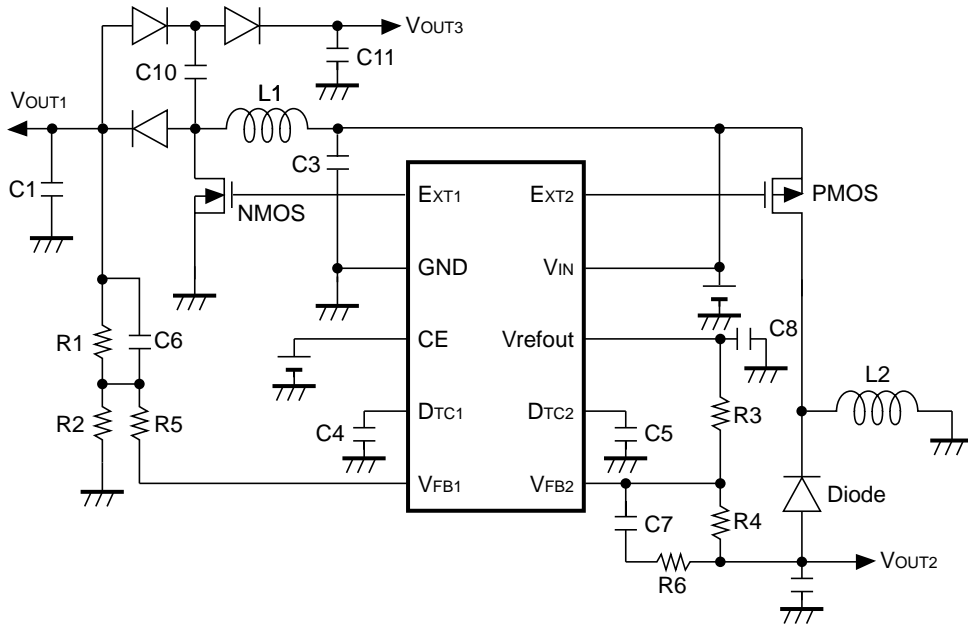

External Components

Inductor L1,2: 6.8 μ H, VLF504012MT (TDK)

Diode: CRS10I30A (Toshiba)

NMOS: IRF7601 (International Rectifier)

PMOS: Si3443DV (Siliconix)

Resistors: R1, R2, R3, and R4 are for Setting Output Voltage. Recommendation values are R1+R2 100k Ω or R3+R4 100k Ω , R5=43k Ω , R6=10k Ω ,

Capacitors: Ceramic Capacitor

(Example)

R1280D002B: C1=C2=10 μ F, C3=4.7 μ F, C4=0.22 μ F, C5=0.33 μ F, C6=120pF, C7=50pF, C8=C10=C11=1 μ F

This IC can be used 3 Output TFT Bias Circuit as shown above. $V_{OUT3}=2 \times V_{OUT1} - V_f$

Note: Maximum voltage tolerance of each component should be considered. The transistor shown above is appropriate to set up to +15V as V_{OUT1} , -15V as V_{OUT2} , 30V as V_{OUT3}

- R1280D002A/C

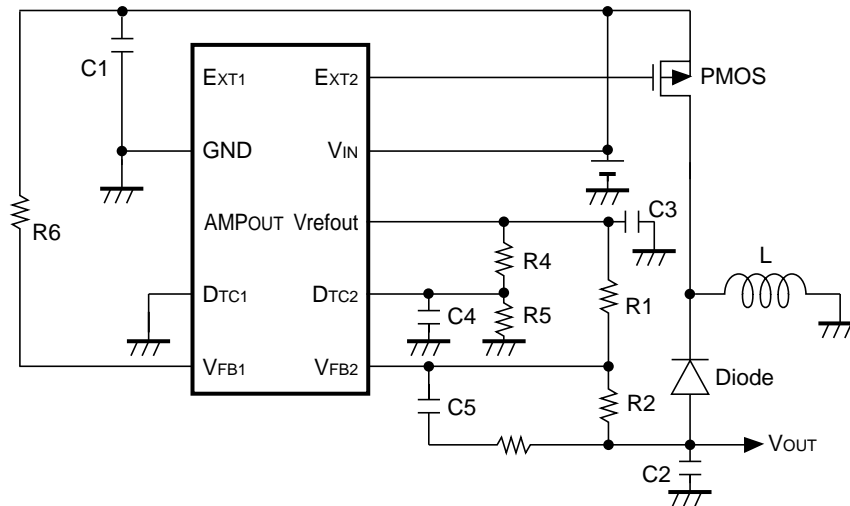

Components examples

Inductor L: 6.8 μ H VLF504012MT (TDK) (R1280D002C: 22 μ H)

Diode: CRS10I30A (Toshiba)

PMOS: Si3443DV (Siliconix)

Resistance: As setting resistors total value for the output voltage, R1+R2 should be 100k Ω or less.

R1=10k Ω R2=68k Ω R3=10k Ω R4=22k Ω

R5=43k Ω R6=1k Ω

*In the circuit above, output, V_{OUT}=-10V

Capacitors Ceramic Type

R1280D002A Ex.)

C1=4.7 μ F C2=10 μ F C3=1 μ F C4=0.47 μ F C5= 50pF

R1280D002C Ex.)

C1=4.7 μ F C2=10 μ F C3=1 μ F C4=0.47 μ F C5=330pF

As for R1280D002B, when DTC1 is OPEN and V_{FB1}=V_{DD}, then the R1280D002B can be used as an inverting controller without step-up channel.

Note: Consider the ratings of external components including voltage tolerance. With the transistor in the circuit above, V_{OUT}=-15V is the voltage setting limit.

If this IC is used as an inverting controller without step-up channel, V_{refout} pin and V_{FB1}, DTC1 pin should not connect one another. Both the direct connection and via resistor are not permitted.

EXTERNAL COMPONENTS

1. How to set the output voltages

As for step-up side, feedback (V_{FB1}) pin voltage is controlled to maintain 1V, therefore,

$$V_{OUT1}: R1+R2=V_{FB1}: R2$$

Thus, $V_{OUT1}=V_{FB1}\times(R1+R2)/R2$

Output Voltage is adjustable with R1 and R2.

As for inverting side, Feedback (V_{FB2}) pin voltage is controlled to maintain 0V, therefore,

$$V_{refout} : R3=|-V_{OUT2}|:R4$$

Thus, $|-V_{OUT2}|=V_{refout}\times R4/R3$

Output Voltage is adjustable with R3 and R4.

2. How to set Soft-Start Time

As for R1280D002B, soft-start time is adjustable with connecting a capacitor to DTC pin.

Soft starting time, T_{SS1} and T_{SS2} are adjustable. Soft-start time can be set with the time constant of RC.

Soft-start time can be described as in next formula. ($T_{opt}=25^{\circ}\text{C}$)

$$T_{SS1}\cong RS1\times C4, T_{SS2}\cong RS2\times C5$$

In the above formulas, RS1 value is Typ. 32k Ω , while RS2 value is Typ. 45k Ω . Tolerance of these values is $\pm 25\%$ caused by dispersion of wafer process parameters.

On the other hand, as for R1280D002A/C, each soft-start time is set with the time constant of each external resistors and capacitor shown as in the next formula.

$$T_{SS1}\cong R_{O1}\times C4, T_{SS2}\cong R_{O2}\times C5$$

In the above formula, $R_{O1}=(R7\times R8)/(R7+R8)$, $R_{O2}=(R9\times R10)/(R9+R10)$

TECHNICAL NOTES on EXTERNAL COMPONENTS

- External components should be set as close to this IC as possible. Especially, wiring of the capacitor connected to V_{IN} pin should be as short as possible.
- Enforce the ground wire. Large current caused by switching operation flows through GND pin. If the impedance of ground wire is high, internal voltage level of this IC might fluctuate and operation could be unstable.
- Recommended capacitance value of C3 is equal or more than $4.7\mu\text{F}$. Recommended maximum voltage tolerance of C3 is three times as large as set output voltage or more, because the external transistor might generate a high voltage with a shape of spike because of an effect from inductor.
- If the spike noise of V_{OUT} is too large, the noise is feedback from V_{FB1} pin and operation might be unstable. In that case, use the resistor ranging from $10\text{k}\Omega$ to $50\text{k}\Omega$ as R5 and try to reduce the noise level. In the case of V_{OUT2} , use the resistor as much as $10\text{k}\Omega$ as R6.
- Select an inductor with low D.C. current, large permissible current, and uneasy to cause magnetic saturation. If the inductance value is too small, IL_x might be beyond the absolute maximum rating at the maximum load.
- Select a Schottky diode with fast switching speed and large enough permissible current.
- Recommended capacitance value of C1 and C2 is as much as Ceramic $10\mu\text{F}$. In case that the operation with the system of DC/DC converter would be unstable, add a series resistor less than 0.5Ω to each output capacitor or use tantalum capacitors with appropriate ESR. If you choose too large ESR, ripple noise may be forced to V_{FB1} and V_{FB2} , and unstable operation may result. Use a capacitor with three times as large as voltage tolerance of the capacitor.
- In this IC, for the test efficiency, Latch release function is included. By forcing $(V_{IN}-0.3)\text{V}$ or more voltage to DTC1 pin or DTC2 pin, Latch release function works.
- Consider the threshold voltage of Power MOSFET transistor. Select an appropriate MOSFET transistor, depending on the input voltage in order to make the MOSFET turn on completely.
- Performance of the power controller with using this IC depends on external components. Each component, layout should not be beyond each absolute maximum rating such as voltage, current, and power dissipation.



1. The products and the product specifications described in this document are subject to change or discontinuation of production without notice for reasons such as improvement. Therefore, before deciding to use the products, please refer to Ricoh sales representatives for the latest information thereon.
2. The materials in this document may not be copied or otherwise reproduced in whole or in part without prior written consent of Ricoh.
3. Please be sure to take any necessary formalities under relevant laws or regulations before exporting or otherwise taking out of your country the products or the technical information described herein.
4. The technical information described in this document shows typical characteristics of and example application circuits for the products. The release of such information is not to be construed as a warranty of or a grant of license under Ricoh's or any third party's intellectual property rights or any other rights.
5. The products listed in this document are intended and designed for use as general electronic components in standard applications (office equipment, telecommunication equipment, measuring instruments, consumer electronic products, amusement equipment etc.). Those customers intending to use a product in an application requiring extreme quality and reliability, for example, in a highly specific application where the failure or misoperation of the product could result in human injury or death (aircraft, spacevehicle, nuclear reactor control system, traffic control system, automotive and transportation equipment, combustion equipment, safety devices, life support system etc.) should first contact us.
6. We are making our continuous effort to improve the quality and reliability of our products, but semiconductor products are likely to fail with certain probability. In order to prevent any injury to persons or damages to property resulting from such failure, customers should be careful enough to incorporate safety measures in their design, such as redundancy feature, fire containment feature and fail-safe feature. We do not assume any liability or responsibility for any loss or damage arising from misuse or inappropriate use of the products.
7. Anti-radiation design is not implemented in the products described in this document.
8. The X-ray exposure can influence functions and characteristics of the products. Confirm the product functions and characteristics in the evaluation stage.
9. WLCSP products should be used in light shielded environments. The light exposure can influence functions and characteristics of the products under operation or storage.
10. There can be variation in the marking when different AOI (Automated Optical Inspection) equipment is used. In the case of recognizing the marking characteristic with AOI, please contact Ricoh sales or our distributor before attempting to use AOI.
11. Please contact Ricoh sales representatives should you have any questions or comments concerning the products or the technical information.



Ricoh is committed to reducing the environmental loading materials in electrical devices with a view to contributing to the protection of human health and the environment.

Ricoh has been providing RoHS compliant products since April 1, 2006 and Halogen-free products since April 1, 2012.

RICOH RICOH ELECTRONIC DEVICES CO., LTD.

<https://www.e-devices.ricoh.co.jp/en/>

Sales & Support Offices

Ricoh Electronic Devices Co., Ltd.

Shin-Yokohama Office (International Sales)

2-3, Shin-Yokohama 3-chome, Kohoku-ku, Yokohama-shi, Kanagawa, 222-8530, Japan
Phone: +81-50-3814-7687 Fax: +81-45-474-0074

Ricoh Americas Holdings, Inc.

675 Campbell Technology Parkway, Suite 200 Campbell, CA 95008, U.S.A.
Phone: +1-408-610-3105

Ricoh Europe (Netherlands) B.V.

Semiconductor Support Centre

Prof. W.H. Keesomlaan 1, 1183 DJ Amstelveen, The Netherlands
Phone: +31-20-5474-309

Ricoh International B.V. - German Branch

Semiconductor Sales and Support Centre

Oberrather Strasse 6, 40472 Düsseldorf, Germany
Phone: +49-211-6546-0

Ricoh Electronic Devices Korea Co., Ltd.

3F, Haesung Bldg, 504, Teheran-ro, Gangnam-gu, Seoul, 135-725, Korea
Phone: +82-2-2135-5700 Fax: +82-2-2051-5713

Ricoh Electronic Devices Shanghai Co., Ltd.

Room 403, No.2 Building, No.690 Bibo Road, Pu Dong New District, Shanghai 201203,
People's Republic of China
Phone: +86-21-5027-3200 Fax: +86-21-5027-3299

Ricoh Electronic Devices Shanghai Co., Ltd.

Shenzhen Branch

1205, Block D (Jinlong Building), Kingkey 100, Hongbao Road, Luohu District,
Shenzhen, China
Phone: +86-755-8348-7600 Ext 225

Ricoh Electronic Devices Co., Ltd.

Taipei office

Room 109, 10F-1, No.51, Hengyang Rd., Taipei City, Taiwan (R.O.C.)
Phone: +886-2-2313-1621/1622 Fax: +886-2-2313-1623