

**GLASS PASSIVATED  
JUNCTION PLASTIC RECTIFIER**

**VOLTAGE RANGE 50 to 1000 Volts CURRENT 2.0 Amperes**

**FEATURES**

- \* Low cost
- \* Low leakage
- \* Low forward voltage drop
- \* High current capability
- \* Glass passivated junction

**MECHANICAL DATA**

- \* Case: Molded plastic
- \* Epoxy: Device has UL flammability classification 94V-O
- \* Lead: MIL-STD-202E method 208C guaranteed
- \* Mounting position: Any
- \* Weight: 0.38 gram

**MAXIMUM RATINGS AND ELECTRICAL CHARACTERISTICS**

Ratings at 25 °C ambient temperature unless otherwise specified.  
Single phase, half wave, 60 Hz, resistive or inductive load.  
For capacitive load, derate current by 20%.

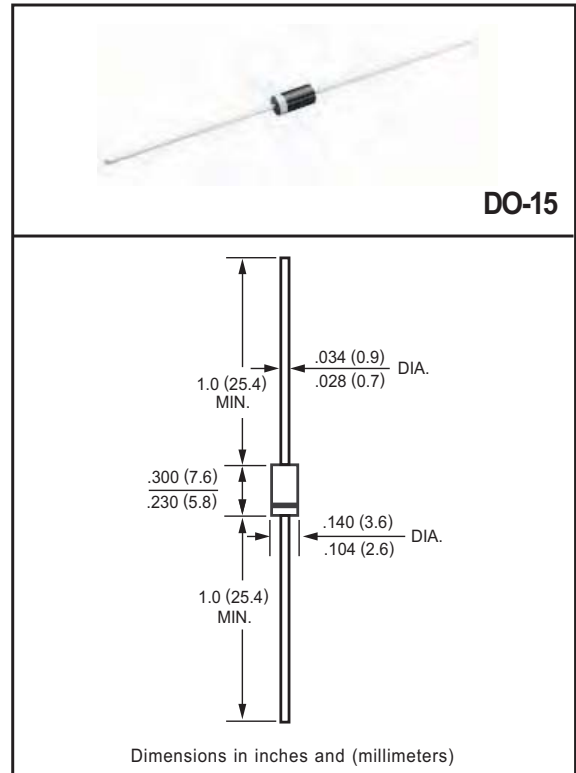

**MAXIMUM RATINGS** (At TA = 25°C unless otherwise noted)

RATINGS	SYMBOL	RL201G	RL202G	RL203G	RL204G	RL205G	RL206G	RL207G	UNITS
Maximum Recurrent Peak Reverse Voltage	V <sub>RRM</sub>	50	100	200	400	600	800	1000	Volts
Maximum RMS Voltage	V <sub>RMS</sub>	35	70	140	280	420	560	700	Volts
Maximum DC Blocking Voltage	V <sub>DC</sub>	50	100	200	400	600	800	1000	Volts
Maximum Average Forward Rectified Current at TA = 75°C	I <sub>O</sub>	2.0							Amps
Peak Forward Surge Current, 8.3 ms single half sine-wave superimposed on rated load (JEDEC method)	I <sub>FSM</sub>	70							Amps
Typical Current Squared Time	I <sup>2</sup> t	20.3							A <sup>2</sup> /S
Typical Junction Capacitance (Note)	C <sub>J</sub>	20							pF
Typical Thermal Resistance	R <sub>qJA</sub>	40							°C/W
Operating and Storage Temperature Range	T <sub>J</sub> , T <sub>STG</sub>	-55 to + 150							°C

**ELECTRICAL CHARACTERISTICS** (At TA = 25°C unless otherwise noted)

CHARACTERISTICS	SYMBOL	RL201G	RL202G	RL203G	RL204G	RL205G	RL206G	RL207G	UNITS
Maximum Instantaneous Forward Voltage at 2.0A DC	V <sub>F</sub>	1.0							Volts
Maximum DC Reverse Current at Rated DC Blocking Voltage	@TA = 25°C	1.0							uAmps
	@TA = 100°C	50							
Maximum Full Load Reverse Current Average, Full Cycle .375" (9.5mm) lead length at TL = 75°C	I <sub>R</sub>	30							uAmps

NOTES : 1. Measured at 1MHz and applied reverse voltage of 4.0 volts  
2. Available in Halogen-free epoxy by adding suffix -HF after the part nbr.

2016-09  
REV: A

# RATING AND CHARACTERISTIC CURVES ( RL201G THRU RL207G )

FIG. 1 - TYPICAL FORWARD CURRENT DERATING CURVE

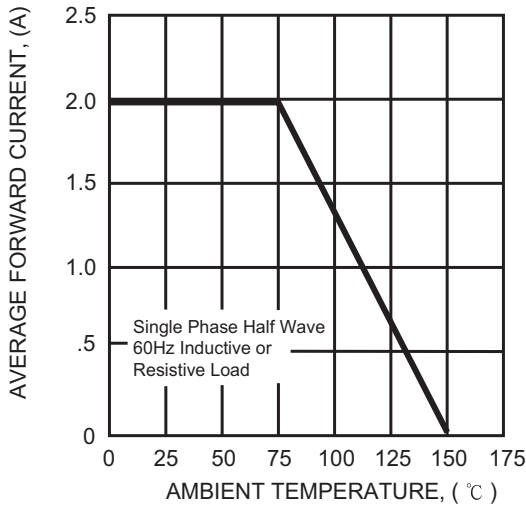

FIG. 2 - TYPICAL INSTANTANEOUS FORWARD CHARACTERISTICS

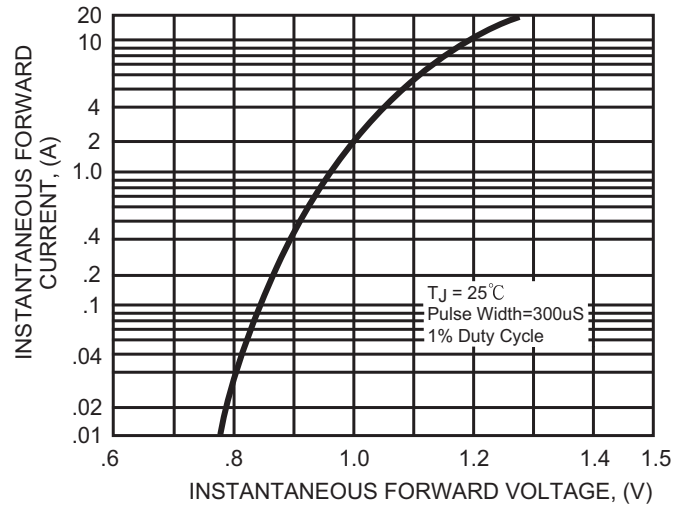

FIG. 3 - MAXIMUM NON-REPETITIVE FORWARD SURGE CURRENT

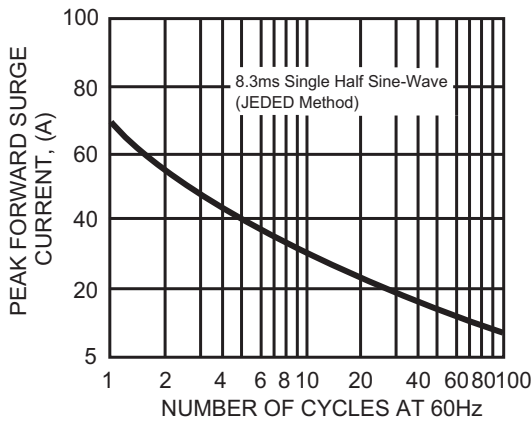

FIG. 4 - TYPICAL REVERSE CHARACTERISTICS

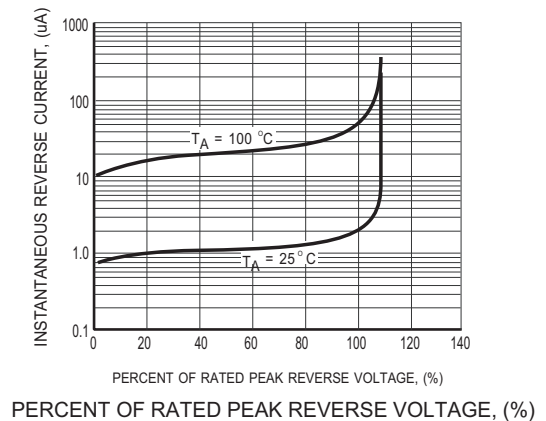
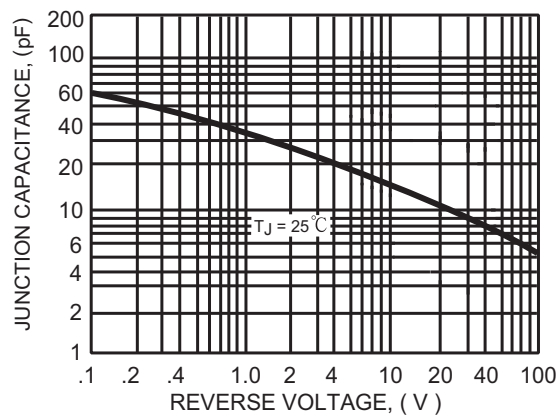

FIG. 5 - TYPICAL JUNCTION CAPACITANCE



# AXIAL LEAD TAPING SPECIFICATIONS FOR RECTIFIERS

Axial lead devices are packed in accordance with EIA standard RS-296-D and specifications given below.

COMPONENT OUTLINE	COMPONENT PITCH A	INNER TAPE PITCH B		CUMULATIVE PITCH TOLERANCE
	$\pm 0.5\text{mm} (.020")$	$\pm 0.5\text{mm} (.020")$	$\pm 1.5\text{mm} (.059")$	
T-1	5.0mm	26.0mm		2.0mm/20pitch
R-1	5.0mm	26.0mm		2.0mm/20pitch
A-405	5.0mm	26.0mm		2.0mm/20pitch
A-405	5.0mm		52.4mm	2.0mm/20pitch
DO-41	5.0mm	26.0mm		2.0mm/20pitch
DO-41	5.0mm		52.4mm	2.0mm/10pitch
DO-15	5.0mm		52.4mm	2.0mm/10pitch
R-3	5.0mm		52.4mm	2.0mm/10pitch
DO-201AD	10.0mm		52.4mm	2.0mm/10pitch
R-6	10.0mm		52.4mm	2.0mm/10pitch

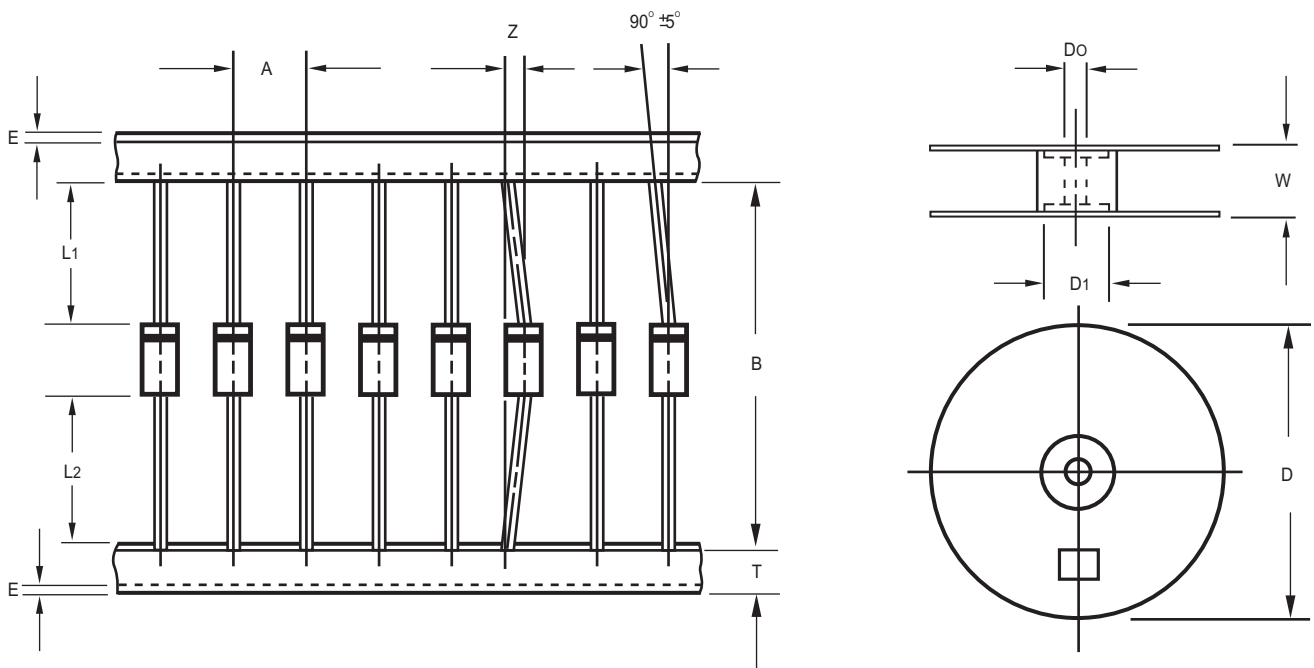

Fig.: Configuration of AXIAL LEAD TAPING

ITEM	SYMBOL	SPECIFICATIONS (mm)	SPECIFICATIONS (inch)
Component alignment	Z	1.2 Max.	0.047 Max.
Tape width	T	$6.0 \pm 0.4$	$0.236 \pm 0.016$
Exposed adhesive	E	0.8 Max.	0.032 Max.
Body eccentricity	$ L1-L2 $	1.0 Max.	0.039 Max.
Reel outside diameter	D	330.0	13.0
Reel inner diameter	D1	$85.7 \pm 0.3$	$3.374 \pm 0.012$
Feed hole diameter	Do	$30.5 \pm 0.4$	$1.201 \pm 0.016$
Reel width	W	$79.0 \pm 1.0$	$3.110 \pm 0.039$

Notes : 1. Each component lead shall be sandwiched between tapes for a minimum of 3.2mm (0.126").  
2. The reel width "W" for 26mm taping is  $50.0 \pm 1.0\text{mm} (1.97" \pm 0.040")$ .

# PACKAGING OF DIODE AND BRIDGE RECTIFIERS

## REEL PACK

PACKAGE	packing code	EA PER REEL	COMPONENT SPACE(mm)	TAPE SPACE (mm)	REEL DIA (mm)	CARTON SIZE (mm)	EA PER CARTON	GROSS WEIGHT(Kg)
R-1	-T	5,000	5.0	52	330	355*360*350	20,000	7.25
A-405	-T	5,000	5.0	330	52	355*360*350	20,000	8.13
DO-41	-T	5,000	5.0	52	330	355*360*350	20,000	10.49
DO-15	-T	4,000	5.0	52	330	355*360*350	16,000	10.05
R-3	-T	3,000	5.0	52	330	355*360*350	12,000	10.37
DO-201AD	-T	1,200	9.5	52	330	355*360*350	4,800	8.93
1.5KE	-T	1,200	10.0	52.4	330	355*360*350	4,800	8.05
R-6	-T	500	9.5	52	330	355*360*350	2,000	7.29
SMA	-T	1,500	---	---	178	465*220*260	48,000	8.40
SMA	-W	5,000	---	---	330	355*360*350	80,000	14.20
MELF	-T	1,500	---	---	178	465*220*260	48,000	11.14
MELF	-W	5,000	---	---	330	355*360*350	80,000	19.60
DB-S	-T	1,000	---	---	330	355*360*350	8,000	9.85
MD	-T	500	---	---	178	465*220*260	16,000	---
MD	-W	3,000	---	---	330	355*360*350	48,000	15.50
SMB	-T	500	---	---	178	465*220*260	16,000	---
SMB	-W	3,000	---	---	330	355*360*350	48,000	13.90
SMC	-T	500	---	---	176	465*220*260	12,000	---
SMC	-W	3,000	---	---	330	355*360*350	24,000	11.50
D2PAK	-W	800	---	---	330	355*360*350	6,400	---

## AMMO PACK

PACKAGE	PACKING CODE	REEL ( EA )	COMPONENT SPACE(mm)	TAPE SPACE (mm)	BOX SIZE (mm)	CARTON SIZE(mm)	CARTON ( EA )	GROSS WEIGHT (Kg)
R-1	-F	3,000	5.0	52	255*73*100	402*270*225	30,000	8.5
A-405	-F	3,000	5.0	52	255*73*100	402*270*225	30,000	9.6
DO-41	-F	3,000	5.0	52	255*73*100	402*270*225	30,000	13.0
DO-15	-F	1,500	5.0	52	255*73*100	402*270*225	15,000	8.8
R-3	-F	1,500	5.0	52	255*73*100	402*270*225	15,000	11.2
DO-201AD	-F	600	9.5	52	255*73*100	402*270*225	6,000	9.9
R-6	-F	300	9.5	52	255*73*100	402*270*225	3,000	8.7
R-1	-E	3,000	5.0	26	256*46*94	347*320*220	42,000	8.35
A-405	-E	3,000	5.0	26	256*46*94	347*320*220	42,000	9.61
DO-41	-E	3,000	5.0	26	256*46*94	347*320*220	42,000	12.41
R-1	-J	3,000	12.7	---	328*170*42	355*360*350	42,000	13.93
R-1	-I	2,000	12.7	---	328*170*42	355*360*350	28,000	9.31
A405	-N	2,000	12.7	---	328*170*42	355*360*350	28,000	11.41

2005-4



## Attachment information about RL20XG

### 1. Internal Circuit



### 2. Marking on the body

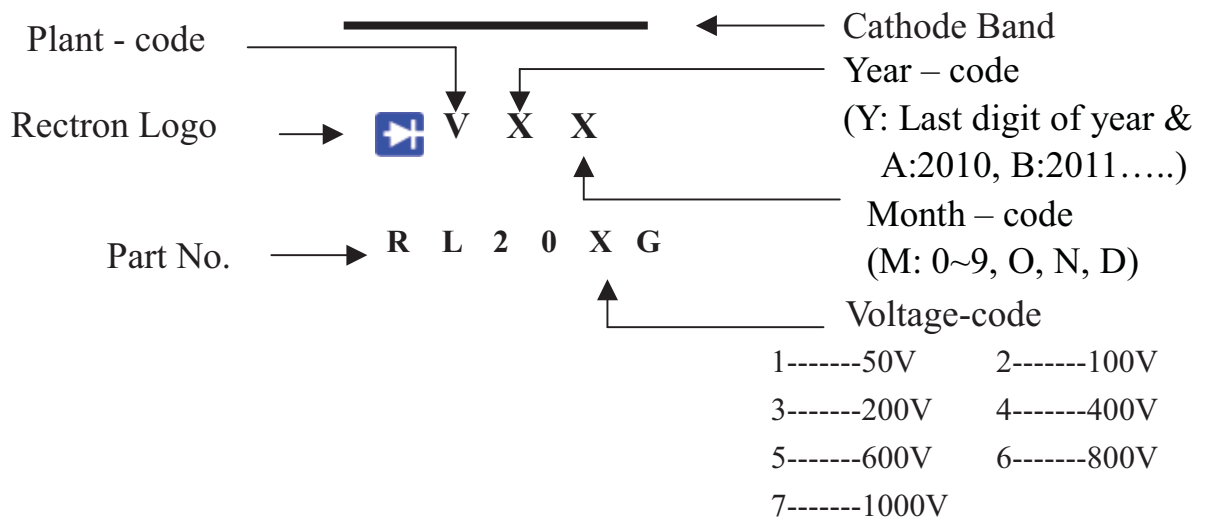

### 3. The net weight 380mg / pcs

### 4. Taping packaging specification

- 4.1 All polarized components must be oriented in one direction.
- 4.2 For diode, at least one side of the cathode lead tape should be red, and anode lead tape should be white.
- 4.3 A minimum 300 mm (12") leader shall be provided at each end of the reel.
- 4.4 Staples shall not be used for splicing. Splice length shall be 4.0 inches minimum and shall not be misaligned more than 0.8mm.



## **Attachment information about RL20XG**

### **5. Items marked on the reel box and carton**

#### **5.1 On the reel (for -T)**

**CUSTOMER**

**TYPE**

**QUANTITY**

**LOT NO.**

**Q.A.**

**REMARK**

#### **5.2 On the box (for -E & -F)**

**TYPE**

**QUANTITY**

**LOT NO.**

**Q.A.**

#### **5.3 On the carton**

**CUSTOMER**

**TYPE**

**QUANTITY**

**LOT NO.**

**REMARK**

## DISCLAIMER NOTICE

Rectron Inc reserves the right to make changes without notice to any product specification herein, to make corrections, modifications, enhancements or other changes. Rectron Inc or anyone on its behalf assumes no responsibility or liability for any errors or inaccuracies. Data sheet specifications and its information contained are intended to provide a product description only. "Typical" parameters which may be included on RECTRON data sheets and/ or specifications can and do vary in different applications and actual performance may vary over time. Rectron Inc does not assume any liability arising out of the application or use of any product or circuit.

Rectron products are not designed, intended or authorized for use in medical, life-saving implant or other applications intended for life-sustaining or other related applications where a failure or malfunction of component or circuitry may directly or indirectly cause injury or threaten a life without expressed written approval of Rectron Inc. Customers using or selling Rectron components for use in such applications do so at their own risk and shall agree to fully indemnify Rectron Inc and its subsidiaries harmless against all claims, damages and expenditures.

