

Q'ty/per	TRAY	CARTON			
		600			
PART NUMBER: XFP001-L					
No.	DESCRIPTION	Q'ty	MATERIAL	PLATING	REMARK
01	XFP CAGE ASSEMBLY (Non-Logo)	1			
02	XFP HEAT SINK (1.7mm)	1	AL	Ni	
03	XFP HEAT SINK CLIP	1	SUS		

← MM →
 (INCH)
 TOLERANCES EXCEPT AS NOTED
 MM
 .0 ± 0.2 ±
 .00 ± 0.15 ±
 .000 ± 0.075 ±
 ANGLES ± 0.5

 THIRD ANGLE PROJECTION

RoHS Compliant

 TITLE (Non-Logo)
 XFP CAGE WITH PCI HEAT SINK KIT
 DFTO Jack DATE 9/21/07' DRAWING NO. XFP001-L /PART NO. SIZE A3 REV 2
 SCALE : 1:1 DO NOT SCALE DRAWING SHEET 1 OF 2

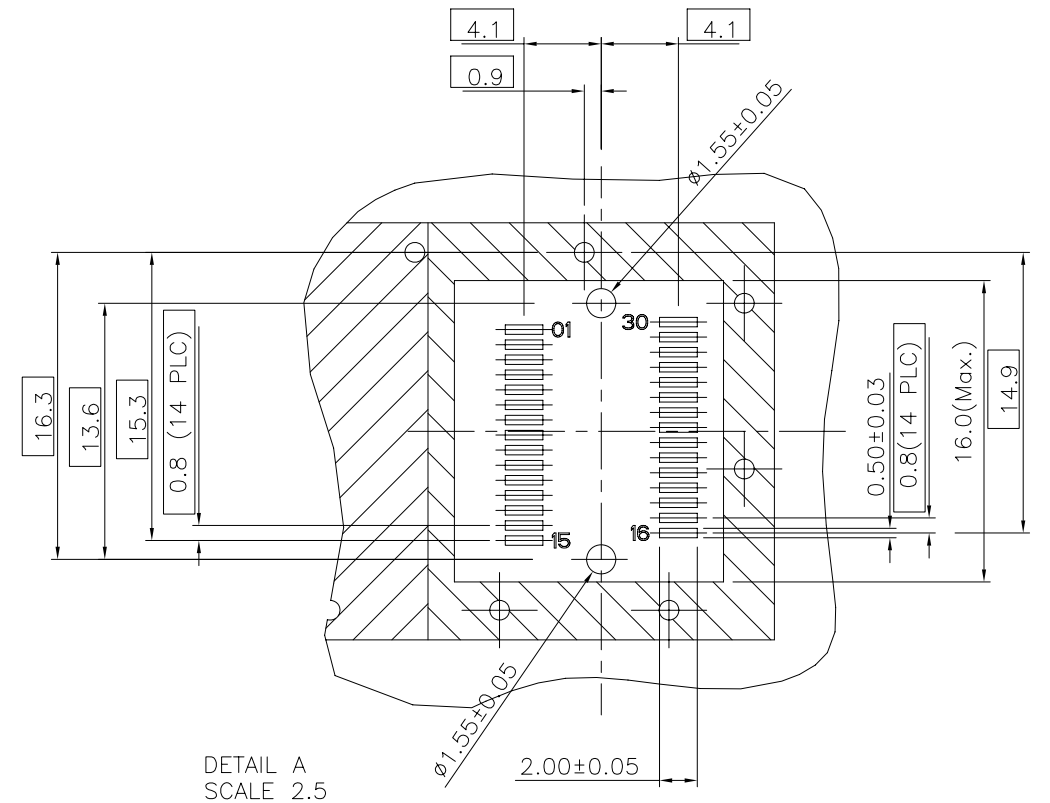
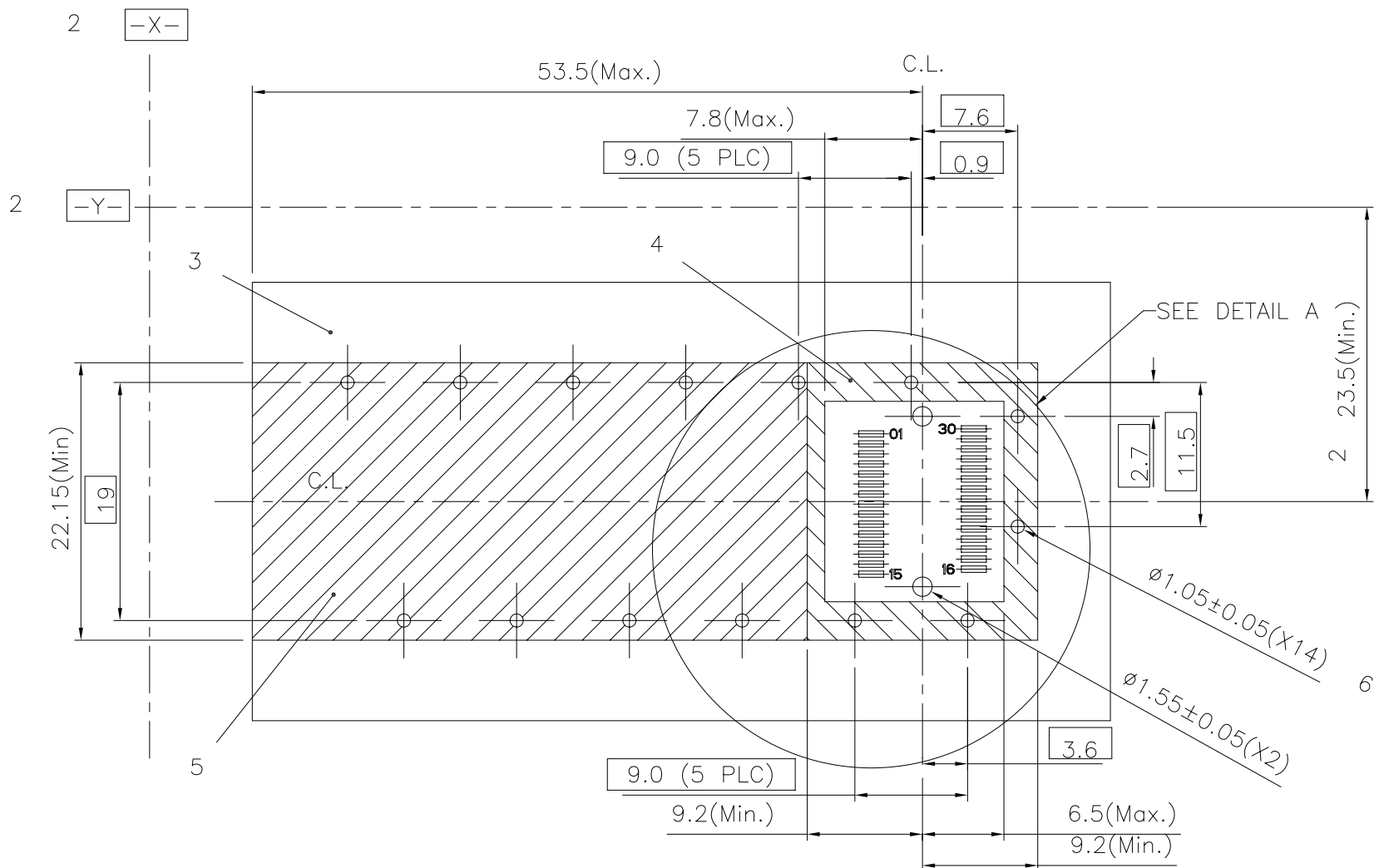

RECOMMEND P.C.B. LAYOUT

Note:

- | | |
|--|---|
| <p>1 DESIGN MEETS REQUIREMENTS OF XFPMSA SPECIFICATION REV. 3.1 (10 GIGABIT SMALL FROM FACTOR PLUGGABLE MODULE).</p> <p>2 DATUM $\boxed{-X-}$ AND $\boxed{-Y-}$ ESTABLISHED BY CUSTOMER.</p> <p>3 DATUM $\boxed{-A-}$ IS TOP SURFACE OF HOST BOARD.</p> <p>4 INDICATED SURFACES TO BE CONDUCTIVE AND CONNECTED TO CHASSIS GROUND.</p> | <p>5 CROSS-HATCHED AREA DENOTES COMPONENT AND TRACE KEEP-OUT (EXCEPT CHASSIS GROUND)</p> <p>6 RECOMMENDATION FOR P.C.BOARD HOLES:
 A. HOLE ϕ AFTER DRILLING : 1.15 ± 0.02 mm.
 B. HOLE ϕ Sn PLATE : 1.05 ± 0.05 mm.
 C. 25um ~ 50um COPPER UNDERPLATE.</p> <p>7 -CAUTION- REFLOW PROCESS WILL DAMAGE CAGE ASSEMBLY.</p> |
|--|---|

DETACHED LISTS		RoHS Compliant				
	TOLERANCES EXCEPT AS NOTED		TITLE (Non-Logo) XFP CAGE WITH PCI HEAT SINK KIT			
	MM	±				
	.0 ± 0.2 .00 ± 0.15 .000 ± 0.075	± ± ±				
ANGLES ± 0.5		DFTO Jack		DRAWING NO. XFP001-L		
 THIRD ANGLE PROJECTION		DATE 9/21/07'		/PART NO.		
		SCALE : 1:1		DO NOT SCALE DRAWING		
				SIZE A3	REV 2	
				SHEET 2	OF 2	

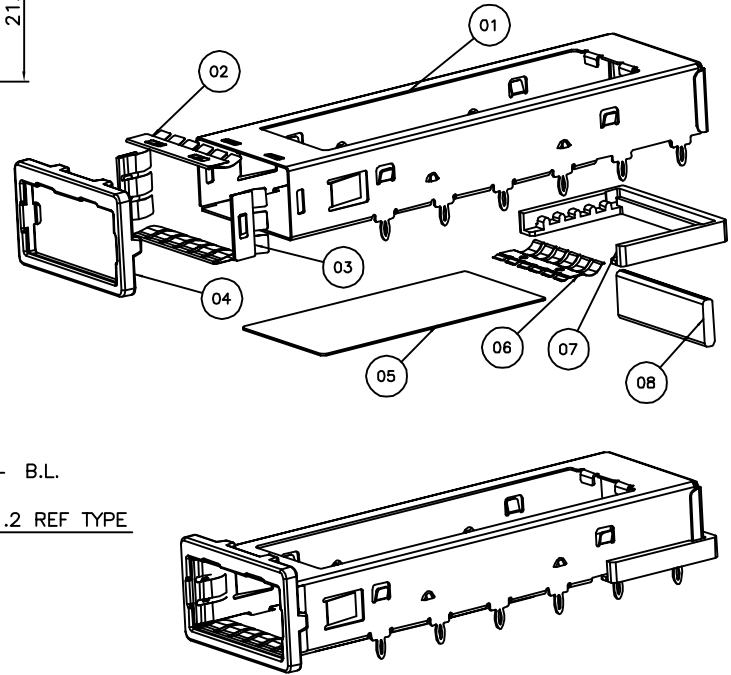
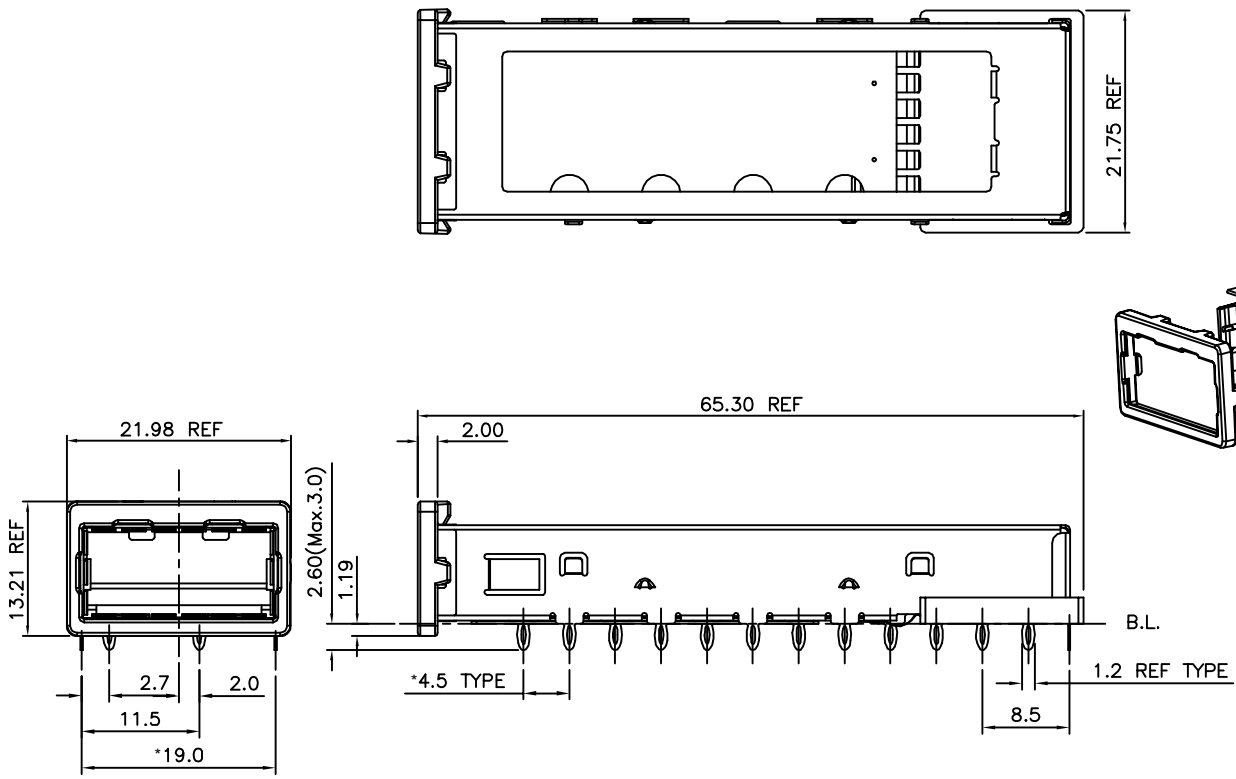

Q'ty	TRAY	CARTON		
		600		
PART NUMBER: XFPCAGE001-L				
No.	DESCRIPTION	Q'ty	MATERIAL	PLATING
01	CAGE HOUSING	1	COPPER ALLOY	
02	FRONT EMI GASKET/UD	2	COPPER ALLOY	Sn
03	FRONT EMI GASKET/RL	2	COPPER ALLOY	Sn
04	FRONT FLANGE	1	ZINC ALLOY	Ni
05	MYLAR	1		
06	INTERMEDIATE REAR EMI GASKET	1	COPPER ALLOY	Sn
07	LOWER REAR EMI GASKET	1	EMI RUBBER	
08	UPPER REAR EMI GASKET	1	EMI PORON	

DETACHED LISTS	 THIRD ANGLE PROJECTION	RoHS Compliant		
	TOLERANCES EXCEPT AS NOTED MM ± .0 ± 0.2 ± .00 ± 0.15 ± .000 ± 0.075 ± ANGLES ± 0.5	TITLE XFP CAGE (Non-Logo)		
	DFTO Jack DATE 4/03/07'	DRAWING NO. XFPCAGE001-L /PART NO.	SIZE A3	REV 1
	SCALE : 1:1	DO NOT SCALE DRAWING	SHEET 1	OF 1

8 | 7 | 6 | 5 | 4 | 3 | 2 | 1

H
G
F
E
D
C
B
A

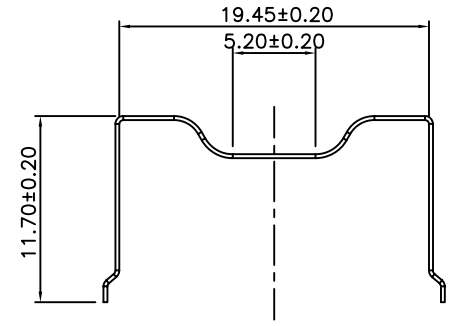
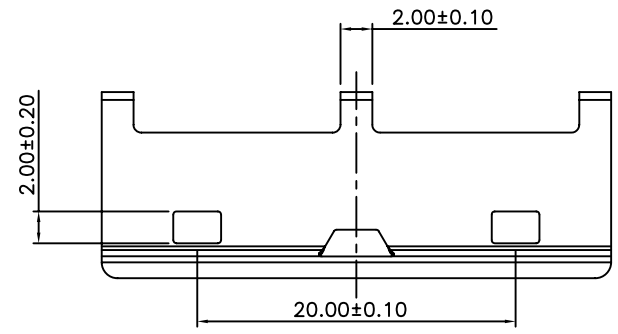
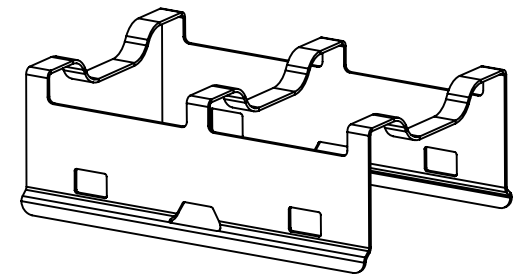
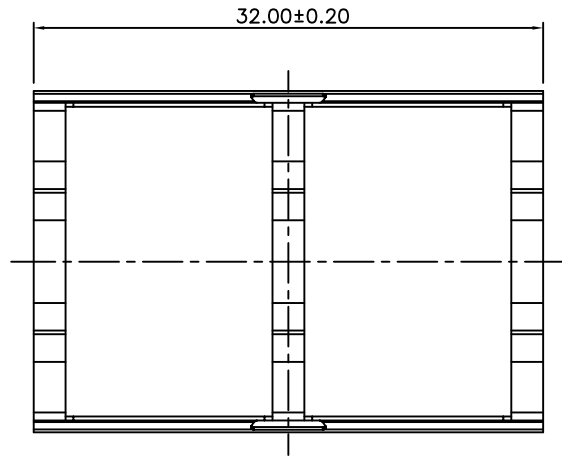

Q'ty	TRAY	CARTON		
		600		
PART NUMBER: XFPCP001-L				
No.	DESCRIPTION	Q'ty	MATERIAL	PLATING
01	CLIP	1	SUS	

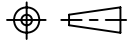
DETACHED LISTS	MM (INCH)	RoHS Compliant			
	TOLERANCES EXCEPT AS NOTED			TITLE XFP CLIP (Non-Logo)	
	MM				
	.0 ± 0.2 ±				
.00 ± 0.15 ±					
.000 ± 0.075 ±					
ANGLES ± 0.5					
	THIRD ANGLE PROJECTION	DFTO Jack	DRAWING NO. XFPCP001-L	SIZE	REV
		DATE 4/03/07'	/PART NO.	A3	1
		SCALE : 1:1	DO NOT SCALE DRAWING	SHEET 1	OF 1

H
G
F
E
D
C
B
A

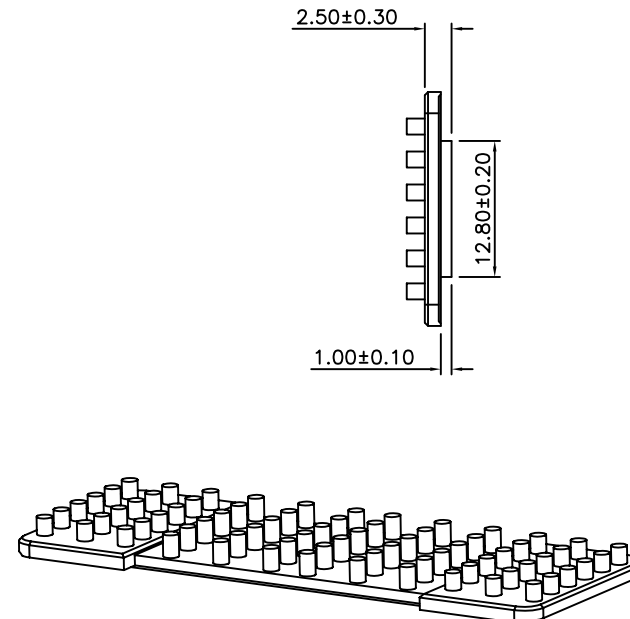
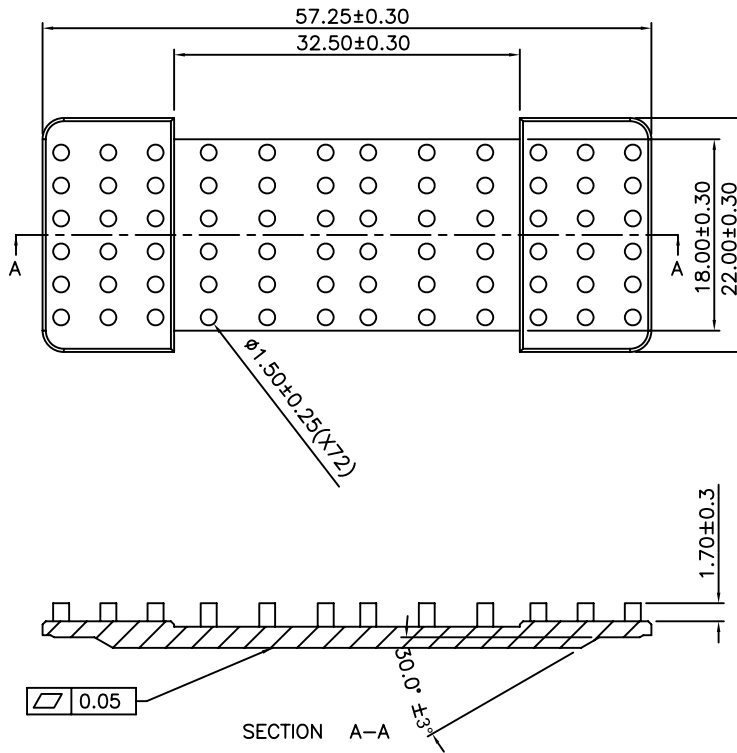

Q'ty	TRAY	CARTON		
		600		
PART NUMBER: XFPHS0170-L				
No.	DESCRIPTION	Q'ty	MATERIAL	PLATING
01	HEAT SINK L=1.7mm	1	Al	NI

MM (INCH)		RoHS Compliant		(Non-Logo)	
TOLERANCES EXCEPT AS NOTED		TITLE XFP HEAT SINK			
MM		DRAWING NO. XFPHS0170-L			
.0 ± 0.2 ±		DATE 4/03/07		/PART NO.	
.00 ± 0.15 ±		SCALE : 1:1		SIZE A3	
.000 ± 0.075 ±		DO NOT SCALE DRAWING		REV 1	
ANGLES ± 0.5		SHEET 1		OF 1	
THIRD ANGLE PROJECTION					

8 7 6 5 4 3 2 1