

Type 2 surge protection plug - VAL-MS 400 ST - 2816399

Please be informed that the data shown in this PDF Document is generated from our Online Catalog. Please find the complete data in the user's documentation. Our General Terms of Use for Downloads are valid (<http://phoenixcontact.com/download>)



Surge protection connector type 2 with high-capacity varistor for VAL-MS base element, thermal monitoring, visual fault warning. Design: 400 V AC

Your advantages

- ✓ Single-channel, DIN-rail mountable protective devices
- ✓ Mechanical coding of all slots
- ✓ Optical, mechanical status indication for the individual arresters
- ✓ Disconnect device on each individual plug
- ✓ Consists of base element and plug
- ✓ Base element with/without floating remote indication contact



Key Commercial Data

Packing unit	10 pc
GTIN	
GTIN	4017918131593

Technical data

Dimensions

Height	52.4 mm
Width	17.5 mm
Depth	55.3 mm
Horizontal pitch	1 Div.

Ambient conditions

Degree of protection	IP20
Ambient temperature (operation)	-40 °C ... 80 °C
Ambient temperature (storage/transport)	-40 °C ... 80 °C
Altitude	≤ 2000 m (amsl (above mean sea level))

Type 2 surge protection plug - VAL-MS 400 ST - 2816399

Technical data

Ambient conditions

Permissible humidity (operation)	5 % ... 95 %
Shock (operation)	25g (Half-sine / 11 ms / 3x ±X, ±Y, ±Z)
Vibration (operation)	5g (10 ... 500 Hz / 2.5 h / X, Y, Z)

General

IEC test classification	II
	T2
EN type	T2
IEC power supply system	TN
	TT
	IT
Mode of protection	L-N
	L-PE
	L-PEN
Mounting type	on base element
Color	jet black RAL 9005
Housing material	PA 6.6
Degree of pollution	2
Flammability rating according to UL 94	V-0
Type	DIN rail module, two-section, divisible
Number of positions	1
Arrester can be tested with CHECKMASTER from software version:	From SW rev. 1.10
Surge protection fault message	optical

Additional descriptions

Note	Usable in all low-voltage systems between L-N or L-PEN. Only usable in IT Systems between L-PE, if the exposed-conductive-parts (bodies) of the equipment of the low-voltage installation is connected to the earthing arrangement of the transformer substation. (interconnected earthing arrangement of the HV-transformer substation with the bodies of the LV-installation. $R_E = R_A$ accordance to IEC 60364-4-442 / VDE 0100-442 Fig. 44D / Example a)
------	---

Protective circuit

Nominal voltage U_N	240/415 V AC (TN)
	240/415 V AC (TT)
	230 V AC (IT)
Nominal frequency f_N	50 Hz (60 Hz)
Maximum continuous voltage U_C	440 V AC
Residual current I_{PE}	≤ 0.45 mA
Standby power consumption P_C	≤ 200 mVA
Nominal discharge current I_n (8/20) μ s	20 kA
Maximum discharge current I_{max} (8/20) μ s	40 kA
Short-circuit current rating I_{SCCR}	25 kA

Type 2 surge protection plug - VAL-MS 400 ST - 2816399

Technical data

Protective circuit

Voltage protection level U_p	≤ 2.2 kV
Residual voltage U_{res}	≤ 2.2 kV (at I_n)
	≤ 1.8 kV (at 10 kA)
	≤ 1.5 kV (at 5 kA)
	≤ 1.4 kV (at 3 kA)
TOV behavior at U_T	440 V AC (5 s / withstand mode)
	440 V AC (120 min / withstand mode)
Response time t_A	≤ 25 ns
Max. backup fuse with branch wiring	125 A (gG)

Connection data

Connection method	pluggable
-------------------	-----------

UL specifications

SPD Type	4CA
Maximum continuous operating voltage MCOV (L-N)	440 V AC
Nom. voltage	400 V AC
Mode of protection	L-N
Power distribution system	Single phase
Nominal frequency	50/60 Hz
Measured limiting voltage MLV (L-N)	2280 V
Nominal discharge current I_n (L-N)	20 kA

Standards and Regulations

Standards/regulations	IEC 61643-11 2011
	EN 61643-11 2012

Environmental Product Compliance

China RoHS	Environmentally Friendly Use Period = 50 years
	For details about hazardous substances go to tab "Downloads", Category "Manufacturer's declaration"

Drawings

Type 2 surge protection plug - VAL-MS 400 ST - 2816399

Circuit diagram



Type 2 surge protection plug - VAL-MS 400 ST - 2816399

Dimensional drawing

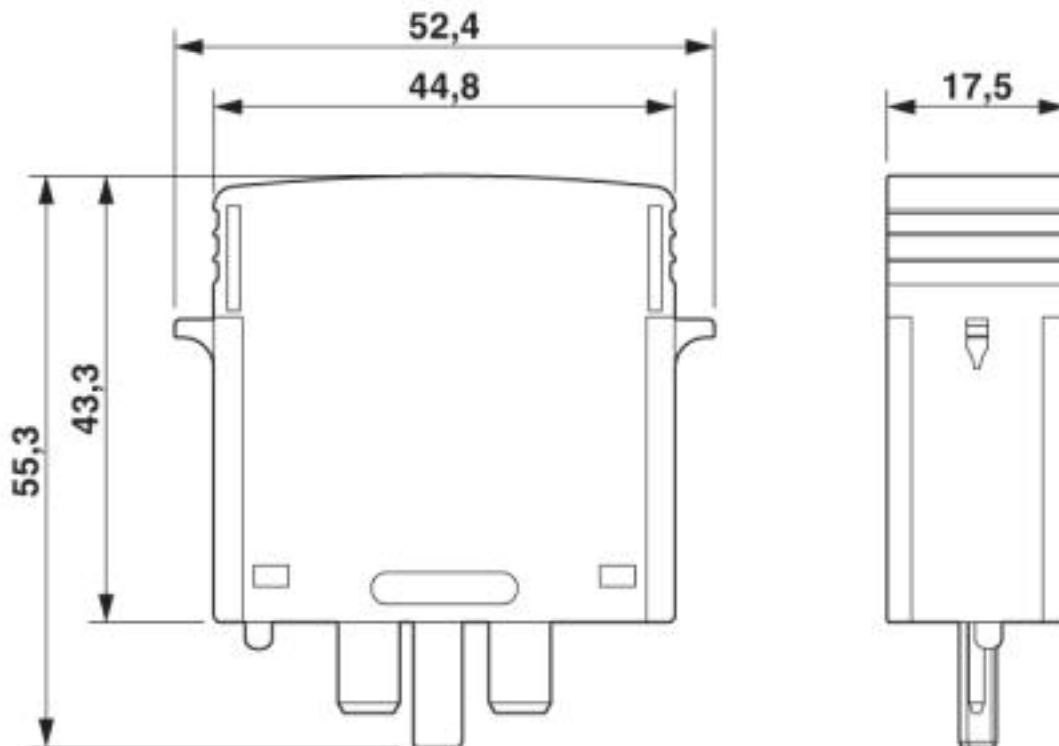

Classifications

eCl@ss

eCl@ss 10.0.1	27130890
eCl@ss 4.0	27130800
eCl@ss 4.1	27130800
eCl@ss 5.0	27130800
eCl@ss 5.1	27130800
eCl@ss 6.0	27130800
eCl@ss 7.0	27130805
eCl@ss 8.0	27130890
eCl@ss 9.0	27130890

ETIM

ETIM 2.0	EC000941
ETIM 3.0	EC000941
ETIM 4.0	EC000941
ETIM 5.0	EC002496
ETIM 6.0	EC000941
ETIM 7.0	EC000941

Type 2 surge protection plug - VAL-MS 400 ST - 2816399

Classifications

UNSPSC

UNSPSC 6.01	30212010
UNSPSC 7.0901	39121610
UNSPSC 11	39121610
UNSPSC 12.01	39121610
UNSPSC 13.2	39121620
UNSPSC 18.0	39121620
UNSPSC 19.0	39121620
UNSPSC 20.0	39121620
UNSPSC 21.0	39121620

Approvals

Approvals

Approvals

CSA / GL / CCA / UL Recognized / KEMA-KEUR / cUL Recognized / IEC EE CB Scheme / ÖVE / EAC / EAC / cULus Recognized

Ex Approvals

Approval details

CSA		http://www.csagroup.org/services-industries/product-listing/	13631
-----	--	---	-------

GL		https://approvalfinder.dnvgl.com/	94385-10 HH
----	--	---	-------------

CCA			NTR-AT 1947-A
-----	--	--	---------------

UL Recognized		http://database.ul.com/cgi-bin/XYV/template/LISEXT/1FRAME/index.htm	FILE E 330181
---------------	--	---	---------------

KEMA-KEUR		http://www.dekra-certification.com	71-113273
-----------	--	---	-----------

Type 2 surge protection plug - VAL-MS 400 ST - 2816399

Approvals

cUL Recognized		http://database.ul.com/cgi-bin/XYV/template/LISEXT/1FRAME/index.htm	FILE E 330181
IECEE CB Scheme		http://www.iecee.org/	AT 2905/M1
ÖVE		https://www.ove.at/zertifizierung-pz/zertifizierungsregister/	18583-001-14
EAC			EAC-Zulassung
EAC			RU C- DE.A*30.B01561
cULus Recognized			

Accessories

Accessories

Bridge

Wiring bridge - MPB 18/1-10/1.0.0 - 2830443



Wiring bridge for modules with connecting pitch 17.5 mm, 1-phase, 10 pitches with contact sequence 1-0-0

Wiring bridge - MPB 18/4- 8 - 2809283



Wiring bridge for modules with connecting pitch 17.5 mm, 4-phase, 8-pos.

Type 2 surge protection plug - VAL-MS 400 ST - 2816399

Accessories

Wiring bridge - MPB 18/3- 6 - 2809241



Wiring bridge for modules with connecting pitch 17.5 mm, 3-phase, 6-pos.

Wiring bridge - MPB 18/1-57 - 2809238



Wiring bridge for modules with connecting pitch 17.5 mm, 1-phase, 57-pos.

Wiring bridge - MPB 18/1-12 - 2748593



Wiring bridge for modules with connecting pitch 17.5 mm, 1-phase, 12-pos.

Wiring bridge - MPB 18/1- 9 - 2748580



Wiring bridge for modules with connecting pitch 17.5 mm, 1-phase, 9-pos.

Wiring bridge - MPB 18/1- 8 - 2748577



Wiring bridge for modules with connecting pitch 17.5 mm, 1-phase, 8-pos.

Type 2 surge protection plug - VAL-MS 400 ST - 2816399

Accessories

Wiring bridge - MPB 18/1- 6 - 2748564



Wiring bridge for modules with connecting pitch 17.5 mm, 1-phase, 6-pos.

Wiring bridge - MPB 18/1- 4 - 2809225



Wiring bridge for modules with connecting pitch 17.5 mm, 1-phase, 4-pos.

Wiring bridge - MPB 18/1- 3 - 2809212



Wiring bridge for modules with connecting pitch 17.5 mm, 1-phase, 3-pos.

Wiring bridge - MPB 18/1- 2 - 2809209



Wiring bridge for modules with connecting pitch 17.5 mm, 1-phase, 2-pos.

Device marking

Zack marker strip - ZBN 18:UNBEDRUCKT - 2809128



Zack marker strip, Strip, white, unlabeled, can be labeled with: CMS-P1-PLOTTER, PLOTMARK, mounting type: snap into tall marker groove, for terminal block width: 18 mm, lettering field size: 18 x 5 mm, Number of individual labels: 5

Labeled device marker

Type 2 surge protection plug - VAL-MS 400 ST - 2816399

Accessories

Marker for terminal blocks - ZBN 18,LGS:ERDE - 2749589



Marker for terminal blocks, Strip, white, labeled, Horizontal: Grounding symbol, mounting type: snap into tall marker groove, for terminal block width: 18 mm, lettering field size: 18 x 5 mm, Number of individual labels: 5

Marker for terminal blocks - ZBN 18,LGS:L1-N,ERDE - 2749576



Marker for terminal blocks, Strip, white, labeled, Horizontal: L1, L2, L3, N, GND, mounting type: snap into tall marker groove, for terminal block width: 18 mm, lettering field size: 18 x 5 mm, Number of individual labels: 5

Marker pen

Marker pen - B-STIFT - 1051993



Marker pen, for manual labeling of unprinted Zack strips, smear-proof and waterproof, line thickness 0.5 mm

Additional products

Type 2 surge protection base element - VAL-MS BE - 2817741



Base element for type 2 arresters of the VALVETRAB MS series of products. Design: 1-channel

Type 2 surge protection base element - VAL-MS BE/FM - 2817738



Base element for type 2 arresters of the VALVETRAB MS series of products, with remote indication contact. Design: 1-channel

Phoenix Contact 2020 © - all rights reserved
<http://www.phoenixcontact.com>

PHOENIX CONTACT GmbH & Co. KG
Flachsmarktstr. 8
32825 Blomberg
Germany
Tel. +49 5235 300
Fax +49 5235 3 41200
<http://www.phoenixcontact.com>