

Antenna - PSI-GSM/UMTS-QB-ANT - 2313371

Please be informed that the data shown in this PDF Document is generated from our Online Catalog. Please find the complete data in the user's documentation. Our General Terms of Use for Downloads are valid (<http://phoenixcontact.com/download>)

GSM UMTS antenna, with omnidirectional characteristic, 2 m antenna cable with SMA round connector



Key Commercial Data

Packing unit	1 pc
GTIN	 4 046356 411066
GTIN	4046356411066

Technical data

Dimensions

Height	21 mm
Diameter	76 mm
Fixed cable length	2.00 m

Ambient conditions

Degree of protection	IP69K (Assembled)
Ambient temperature (operation)	-40 °C ... 85 °C

General

With connecting cable	yes
Frequency range	850 MHz
	900 MHz
	1800 MHz
	1900 MHz
	2100 MHz
Gain	5 dBi (800/900 MHz)
	3 dBi (1800/1900 MHz)
	1 dBi (2100 MHz)
Connection method	SMA (male)

Antenna - PSI-GSM/UMTS-QB-ANT - 2313371

Technical data

General

Fixed cable length	2.00 m
Mounting type	Control cabinet

Conformance/approvals

Designation	EAC
Identification	EAC

Environmental Product Compliance

China RoHS	Environmentally friendly use period: unlimited = EFUP-e
	No hazardous substances above threshold values

Drawings

Schematic diagram

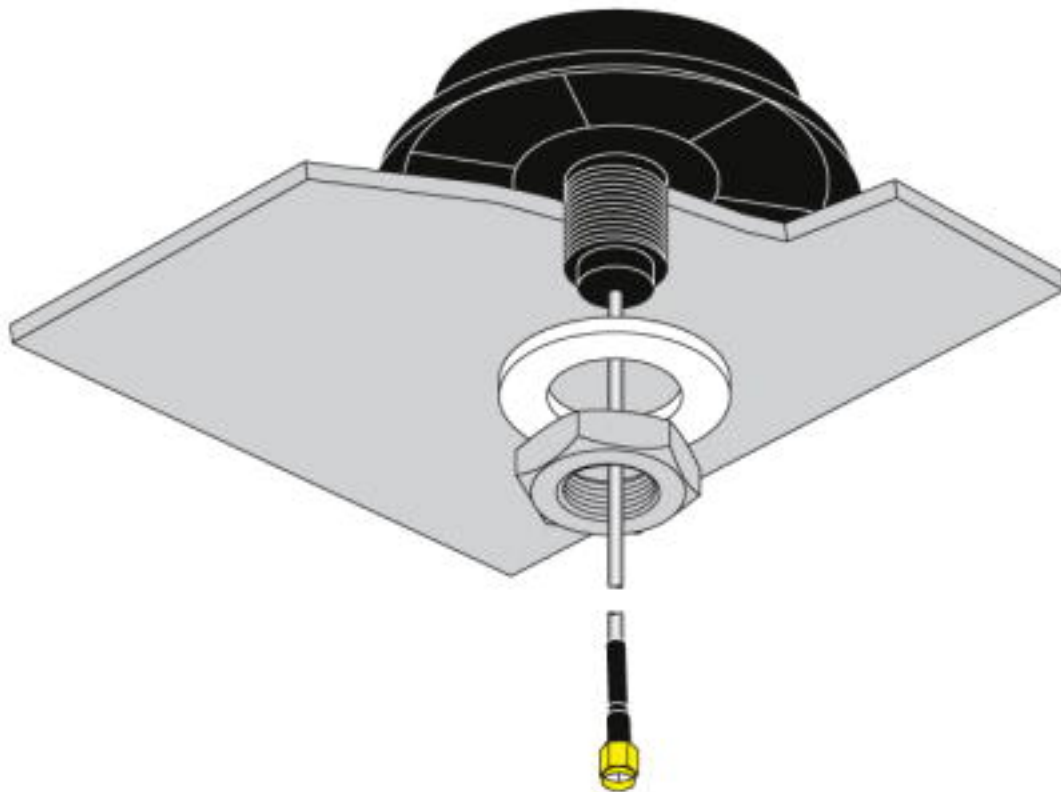

Mounting on the control cabinet

Classifications

eCl@ss

eCl@ss 10.0.1	19070105
eCl@ss 4.0	27060800

Antenna - PSI-GSM/UMTS-QB-ANT - 2313371

Classifications

eCl@ss

eCl@ss 4.1	27060800
eCl@ss 5.0	27061800
eCl@ss 5.1	27061800
eCl@ss 6.0	27061800
eCl@ss 7.0	19070105
eCl@ss 8.0	19070105
eCl@ss 9.0	19070105

ETIM

ETIM 2.0	EC000416
ETIM 3.0	EC000416
ETIM 4.0	EC000416
ETIM 5.0	EC001698
ETIM 6.0	EC001698
ETIM 7.0	EC001698

UNSPSC

UNSPSC 6.01	43171611
UNSPSC 7.0901	43221706
UNSPSC 11	43171611
UNSPSC 12.01	43221706
UNSPSC 13.2	43221715
UNSPSC 18.0	43221715
UNSPSC 19.0	43221715
UNSPSC 20.0	43221715
UNSPSC 21.0	43221715

Approvals

Approvals

Approvals

EAC

Ex Approvals

Approval details

Antenna - PSI-GSM/UMTS-QB-ANT - 2313371

Approvals

EAC		EAC-Zulassung
-----	--	---------------

Accessories

Accessories

Communication module

Communication module - NLC-COM-GSM - 2701344



GSM communication module. Allows SMS messaging to and from the Nanoline controller when connected to the GSM network.

Security router for the DIN rail

Router - TC MGuard RS4000 3G VPN - 2903440



Security appliance, WAN, and cellular interface. SD card slot. 10 VPN tunnels, intelligent firewall with full scope of functions, router with NAT/1:1 NAT, optional CIFS integrity monitoring. 4-port managed switch. 2 SIM card slots. GPS receiver.

Router - TC MGuard RS2000 3G VPN - 2903441



Security appliance with cellular interface. SD card slot. 2 VPN tunnels, 2-click firewall for easy configuration, router with NAT/1:1 NAT. 4-port switch. 2 SIM card slots. GPS receiver.

Interface converter - PSI-GSM/GPRS-MODEM/RS232 - 2708630



Industrial GSM modem for assembly on EN DIN rails. GSM and GPRS. 900 + 1800 MHz. Serial RS-232 interface. Alarm input and output. Supply voltage 24 V AC/DC

Phoenix Contact 2020 © - all rights reserved
<http://www.phoenixcontact.com>

PHOENIX CONTACT GmbH & Co. KG
Flachsmarktstr. 8
32825 Blomberg
Germany
Tel. +49 5235 300
Fax +49 5235 3 41200
<http://www.phoenixcontact.com>