

Protective covers - EV-GBSC - 1623416

Please be informed that the data shown in this PDF Document is generated from our Online Catalog. Please find the complete data in the user's documentation. Our General Terms of Use for Downloads are valid (<http://phoenixcontact.com/download>)



Protective covers, Self-closing, Rear protective cover screw connection, For attaching to infrastructure charging sockets, GB/T, Type 2, GB/T 20234.2, IEC 62196-2, Front mounting, Generation 1, Adhered PHOENIX CONTACT sticker

Product Description

Self-closing protective cover for infrastructure socket outlet

Your advantages

- Certified in accordance with IATF 16949:2016 and ISO 9001:2015



Key Commercial Data

Packing unit	1 pc
GTIN	
GTIN	4055626242903

Technical data

Product definition

Type	Self-closing
	Rear protective cover screw connection
Application	For attaching to infrastructure charging sockets
Affixed logo	Adhered PHOENIX CONTACT sticker
Design	Generation 1
Standards/regulations	GB/T 20234.2
	IEC 62196-2
Charging standard	GB/T
	Type 2
Charging mode	Mode 3, Case B

Dimensions

Height	76.6 mm
Width	76.6 mm

Protective covers - EV-GBSC - 1623416

Technical data

Dimensions

Depth	24.7 mm
Bore dimensions	60 mm

Ambient conditions

Ambient temperature (operation)	-30 °C ... 50 °C
Ambient temperature (storage/transport)	-40 °C ... 80 °C
Degree of protection	IP54

Mounting

Possible mounting positions	Front mounting
	On the right or left side of infrastructure charging sockets
	Rear screw connection
Mounting hole diameter	4.30 mm (ø)

Design

Design line	Generation 1
Housing color	black
Label	14.1 mm x 44.8 mm (customer logo on request)
Customer variations	On request

Material

Material	Plastic
----------	---------

Environmental Product Compliance

REACH SVHC	Lead 7439-92-1
China RoHS	Environmentally Friendly Use Period = 10;
	For details about hazardous substances go to tab "Downloads", Category "Manufacturer's declaration"

Drawings

Protective covers - EV-GBSC - 1623416

Dimensional drawing

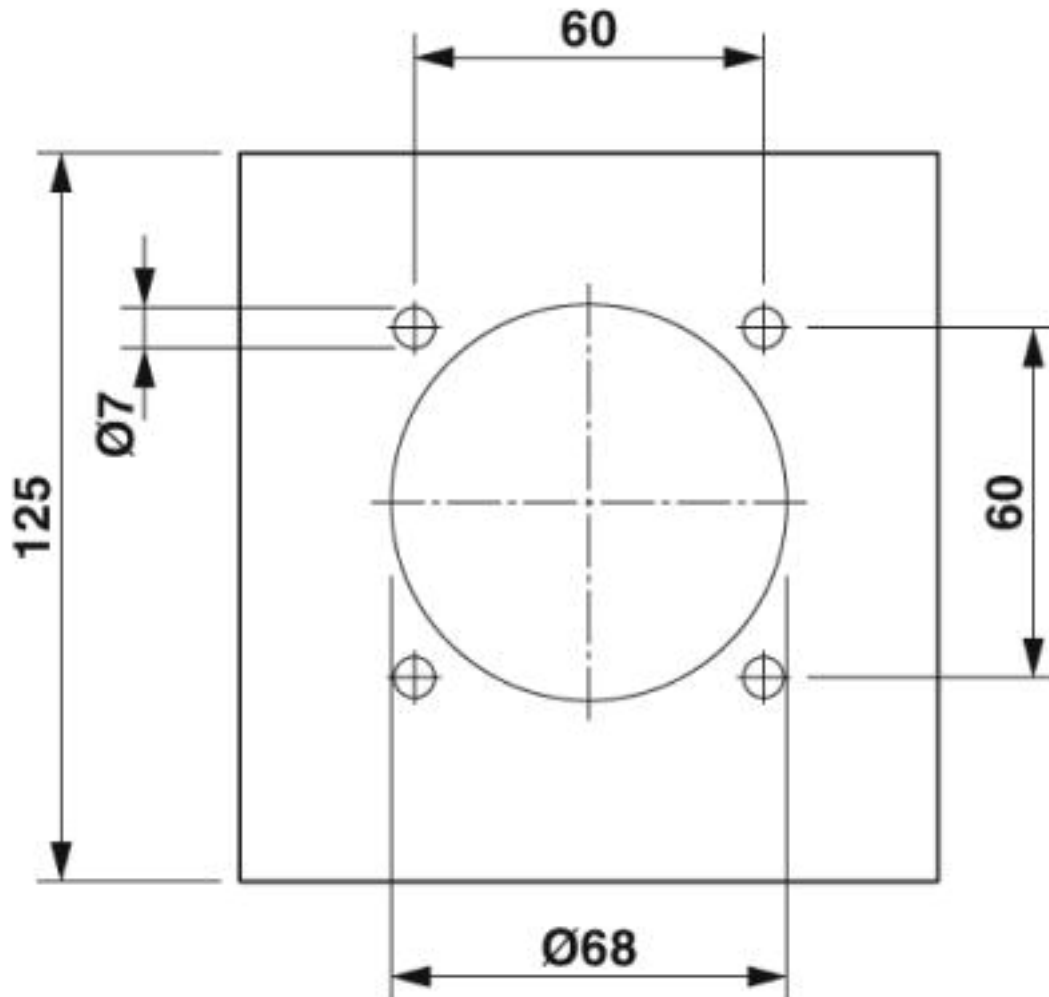

Hole image

Protective covers - EV-GBSC - 1623416

Dimensional drawing

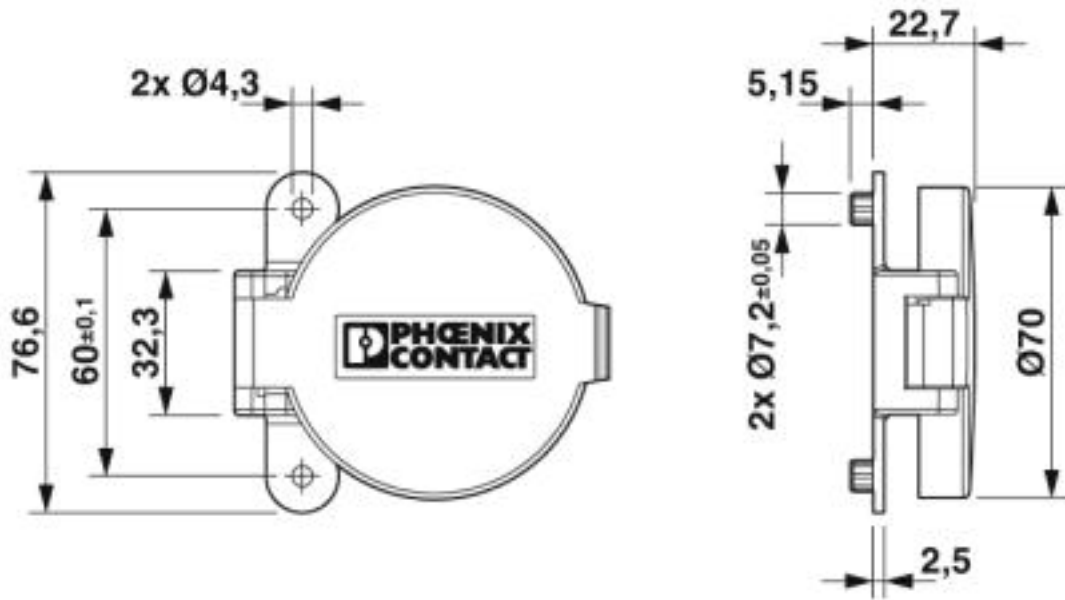

Dimensional drawing

Schematic diagram

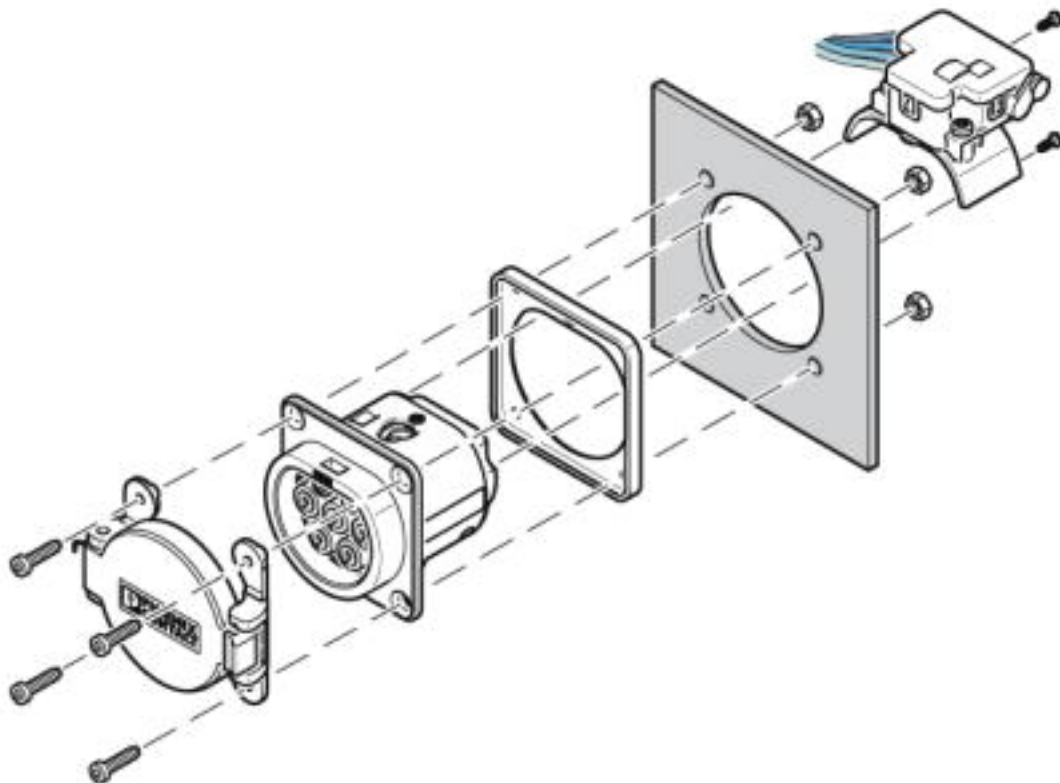

Front mounting with rear protective cover screw connection

Protective covers - EV-GBSC - 1623416

Front mounting is only possible when the locking actuator is removed. The screw connection for a protective cover from the accessories range (EV-GBSC...) only supports rear mounting.

Classifications

eCl@ss

eCl@ss 10.0.1	27144792
eCl@ss 4.0	27141200
eCl@ss 4.1	27141200
eCl@ss 5.0	27149100
eCl@ss 5.1	27149100
eCl@ss 6.0	27261200
eCl@ss 7.0	27440208
eCl@ss 8.0	27440208
eCl@ss 9.0	27144792

ETIM

ETIM 2.0	EC000241
ETIM 3.0	EC002061
ETIM 4.0	EC002061
ETIM 5.0	EC002314
ETIM 6.0	EC002884
ETIM 7.0	EC002884

UNSPSC

UNSPSC 6.01	30211923
UNSPSC 7.0901	39121522
UNSPSC 11	39121522
UNSPSC 12.01	39121522
UNSPSC 13.2	39121522
UNSPSC 18.0	39121522
UNSPSC 19.0	39121522
UNSPSC 20.0	39121522
UNSPSC 21.0	39121522

Accessories

Accessories

Infrastructure socket outlet

Socket Outlet - EV-GBM3S-1AC32A-0,7M6,0E00 - 1408169



Socket Outlet, Rear protective cover screw connection, For charging electric vehicles with alternating current (AC), GB/T, GB/T 20234.2-2015, 32 A / 250 V (AC), Single wires, length: 0.7 m, Front and rear mounting, Standard, NOTE This product version does not include a locking actuator.

Protective covers - EV-GBSC - 1623416

Accessories

Socket Outlet - EV-GBM3S-3AC32A-0,7M6,0E00 - 1408170



Socket Outlet, Rear protective cover screw connection, For charging electric vehicles with alternating current (AC), GB/T, GB/T 20234.2-2015, 32 A / 440 V (AC), Single wires, length: 0.7 m, Front and rear mounting, Standard, NOTE This product version does not include a locking actuator.

Socket Outlet - EV-GBM3SE12-1AC32A-0,7M6,0E10 - 1408171



Socket Outlet, Rear protective cover screw connection, For charging electric vehicles with alternating current (AC), GB/T, GB/T 20234.2-2015, 32 A / 250 V (AC), Single wires, length: 0.7 m, Locking actuator: 12 V, 4-position, Rear panel mounting, Standard

Socket Outlet - EV-GBM3SE12-3AC32A-0,7M6,0E10 - 1408172



Socket Outlet, Rear protective cover screw connection, For charging electric vehicles with alternating current (AC), GB/T, GB/T 20234.2-2015, 32 A / 440 V (AC), Single wires, length: 0.7 m, Locking actuator: 12 V, 4-position, Rear panel mounting, Standard

Phoenix Contact 2020 © - all rights reserved
<http://www.phoenixcontact.com>

PHOENIX CONTACT GmbH & Co. KG
Flachsmarktstr. 8
32825 Blomberg
Germany
Tel. +49 5235 300
Fax +49 5235 3 41200
<http://www.phoenixcontact.com>