

Photovoltaic connector - PV-FT-CF-C-6-500-BK - 1621847

Please be informed that the data shown in this PDF Document is generated from our Online Catalog. Please find the complete data in the user's documentation. Our General Terms of Use for Downloads are valid (<http://phoenixcontact.com/download>)



Photovoltaic connector, Photovoltaic connector, housing material: PPE, color: black, number of positions: 1, min. conductor cross section: 6 mm², Connection method: Crimp, Type of contact: Socket, cable length: 500



Key Commercial Data

Packing unit	50 pc
Minimum order quantity	50 pc
GTIN	 4 046356 988537
GTIN	4046356988537

Technical data

Environmental Product Compliance

China RoHS	Environmentally friendly use period: unlimited = EFUP-e
	No hazardous substances above threshold values

Drawings

Photovoltaic connector - PV-FT-CF-C-6-500-BK - 1621847

Dimensional drawing

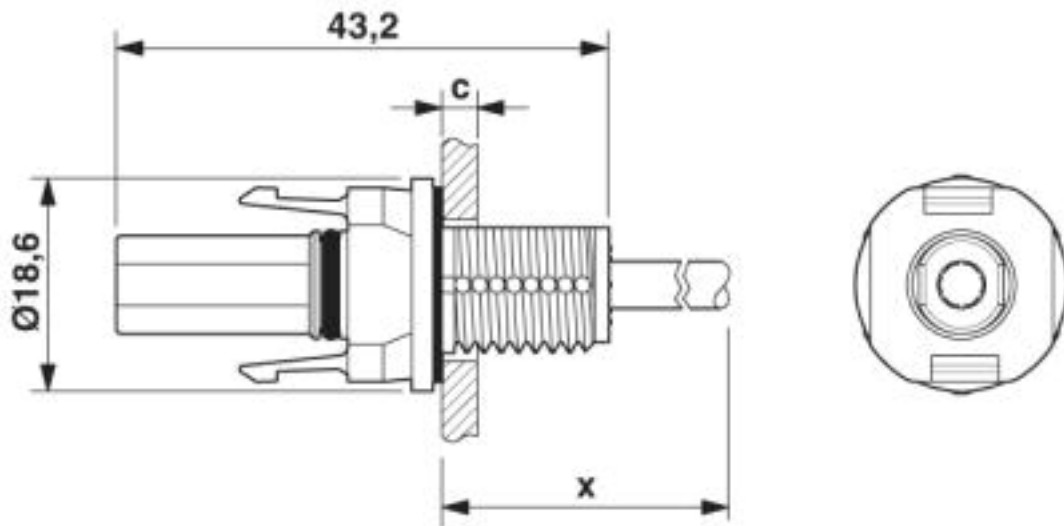

Dimension x = cable length

c: panel thickness - plastic: 2 - 6 mm; metal: 2 - 5 mm

Photovoltaic connector - PV-FT-CF-C-6-500-BK - 1621847

Dimensional drawing

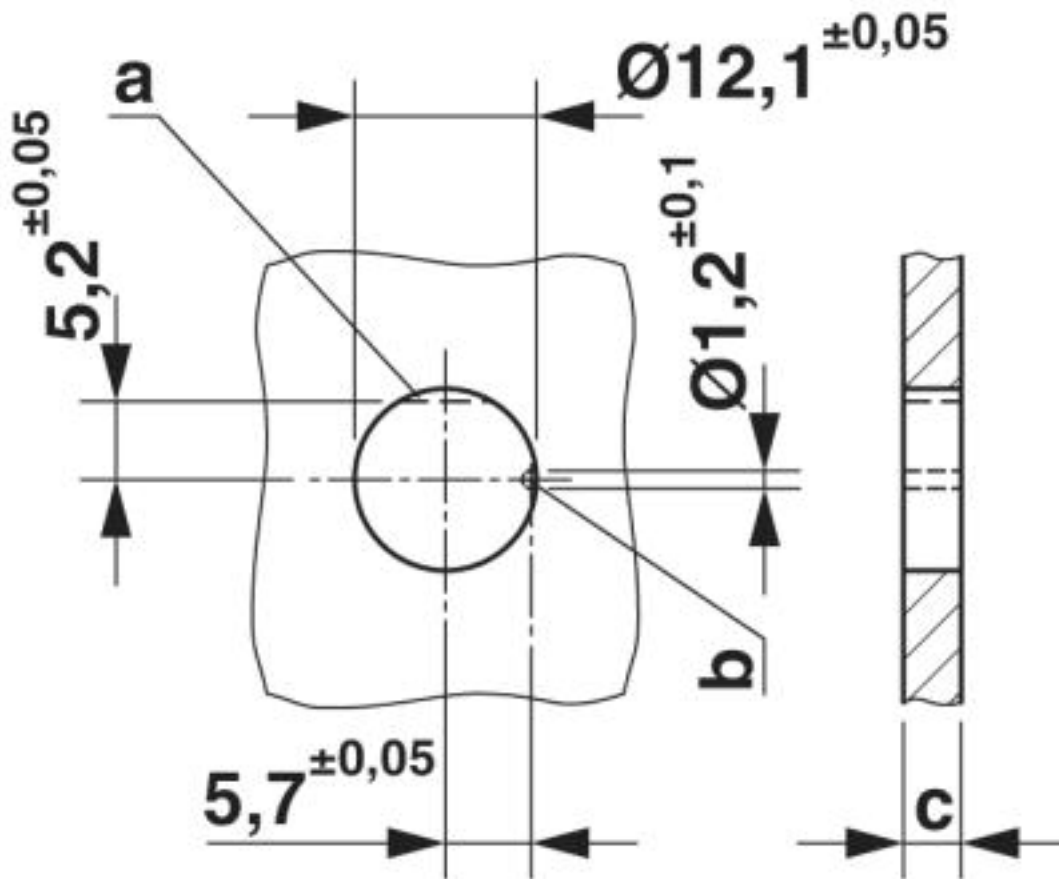

- a: anti-rotation protection
- b: coding
- c: panel thickness - plastic: 2 - 6 mm; metal: 2 - 5 mm

Classifications

eCl@ss

eCl@ss 10.0.1	27440107
eCl@ss 4.0	27260700
eCl@ss 4.1	27260700
eCl@ss 5.0	27260700
eCl@ss 5.1	27260700
eCl@ss 6.0	27260700
eCl@ss 7.0	27440102
eCl@ss 8.0	27440102
eCl@ss 9.0	27440107

ETIM

ETIM 3.0	EC001121
----------	----------

Photovoltaic connector - PV-FT-CF-C-6-500-BK - 1621847

Classifications

ETIM

ETIM 4.0	EC002643
ETIM 5.0	EC002635
ETIM 6.0	EC002061

UNSPSC

UNSPSC 6.01	30211810
UNSPSC 7.0901	39121409
UNSPSC 11	39121409
UNSPSC 12.01	39121409
UNSPSC 13.2	39121413
UNSPSC 18.0	39121413
UNSPSC 19.0	39121413
UNSPSC 20.0	39121413
UNSPSC 21.0	39121413

Approvals

Approvals

Approvals

TÜV Rheinland / EAC

Ex Approvals

Approval details

TÜV Rheinland		http://www.certipedia.com	R 60126961
Nominal voltage UN	1500 V		

EAC		B.01687
-----	---	---------

Accessories

Accessories

Photovoltaic connector

Photovoltaic connector - PV-FT-CF-C-6-500-BK - 1621847

Accessories

Nut - PV-FT-C NUT BK - 1775880



Photovoltaic connector, Range of articles: PV-JB TF, Nut, number of positions: 0

Protective cap - PV-C PROTECTION CAP - 1785430



Photovoltaic connector, Range of articles: SUNCLIX, Protective cap, color: black. self-sealing, without interlock, set consisting of: 1 protective cap for connector side and 1 protective cap for coupling side

Phoenix Contact 2020 © - all rights reserved
<http://www.phoenixcontact.com>

PHOENIX CONTACT GmbH & Co. KG
Flachsmarktstr. 8
32825 Blomberg
Germany
Tel. +49 5235 300
Fax +49 5235 3 41200
<http://www.phoenixcontact.com>